



WHO/EMC/ DIS/97.6

Cholera and other Epidemic Diarrhoeal Diseases Control.
Technical Cards on Environmental Sanitation.
Prepared by the Institute of Water and Sanitation
Development, Harare, Zimbabwe

World Health Organization
Emerging and other Communicable Diseases,
Surveillance and Control

This document has been downloaded from the WHO/EMC Web site. The original cover pages and lists of participants are not included. See <http://www.who.int/emc> for more information.

© World Health Organization

This document is not a formal publication of the World Health Organization (WHO), and all rights are reserved by the Organization. The document may, however, be freely reviewed, abstracted, reproduced and translated, in part or in whole, but not for sale nor for use in conjunction with commercial purposes.

The views expressed in documents by named authors are solely the responsibility of those authors. The mention of specific companies or specific manufacturers' products does not imply that they are endorsed or recommended by the World Health Organization in preference to others of a similar nature that are not mentioned.

FOREWORD

As part of the overall efforts involved in the control of cholera and other epidemic diarrhoeal diseases, WHO in a joint effort between EMC, REH and AFRO agreed that a set of pictorial technical cards on different key aspects of environmental sanitation should be prepared to help carry out technical interventions in a situation of epidemic or pre-epidemic.

The objectives of this set of technical cards are the following:

- To serve as practical tools to be used by the appropriate individuals for the construction of low cost facilities and conducting basic environmental sanitation operations for the prevention of cholera and other epidemic diarrhoeal diseases;
- To be used as an environmental sanitation tool in the implementation of projects on cholera and other diarrhoeal diseases control.
- To serve as a simplified guide on environmental sanitation in situations of cholera epidemics.

These technical cards including the figures and graphics are intended to be self-contained. However, should additional information be required, it might be found in WHO's document: Fact Sheets on Environmental Sanitation, Geneva, 1996.

Two groups of target users of this document are envisaged:

- the ultimate target users, consisting of those responsible for the field supervision of the work of operations described in the technical cards. These users will require training on the technical aspects of the cards so that they will be in a position to follow the instructions of the cards without having to use additional information.
- the intermediate users, consisting of those responsible for training field supervisors. The intermediate users might require training not only on the technical aspects of the cards but also on how to train the ultimate target users.

This document was prepared by the Institute of Water and Sanitation Development, Harare, Zimbabwe under contractual agreement with World Health Organisation. Most of the technical cards included in this folder were based on WHO's document "Fact Sheets on Environmental Sanitation" prepared by the Robens Institute, Geneva, 1996.

TECHNICAL CARDS CONTAINED IN THIS FOLDER

Planning and management topics

1. Emergency Interventions For Cholera Outbreaks
2. Estimating Requirements For Water Quality Monitoring And Control
3. Community Planning For Diarrhoeal Disease Control

Technology selection and construction topics

4. Well Sinking In Non Collapsing Formations
5. Spring Protection
6. Excreta Disposal Options
7. Septic Tank Systems For Peri Urban Areas
8. Ventilated Improved Pit Latrines
9. Rainwater Harvesting Systems

Technology maintenance

10. Afridev Handpump Maintenance
11. Repair Of The Model "A" Bushpump

Water quality and hygiene topics

12. Household Water Treatment And Storage
13. Disinfectants
14. Cleaning And Disinfection Of Wells
15. Dosing Water With Hypochlorite Solutions
16. Testing For Chlorine
17. Cleaning And Disinfection Of Storage Tanks, Tanker Trucks And Pipelines
18. Sanitary Surveillance Of Wells And Boreholes
19. Sanitary Surveillance Of A Distribution System
20. Collection Of Water Samples - Sampling
21. Collecting Water Samples - Methods

This document is not issued to the general public and all rights are reserved by the World Health Organisation. The document may not be reviewed, abstracted, quoted, reproduced or translated, in part or in whole, without the prior permission of WHO. No part of this document may be stored in a retrieval system or transmitted in any form or by any means - electronic, mechanical or other without the prior written permission of WHO.

The views expressed in documents by named authors are solely the responsibility of those authors.

April 1997



EMERGENCY INTERVENTIONS FOR CHOLERA OUTBREAKS

IMMEDIATE

1 From a coordinating committee at national level



2 Prioritize areas of high risk

3 Mobilize resources to the cholera control programme



4 Treat all affected people

5 Improve water quality and waste disposal systems in affected areas

WITHIN ONE MONTH

6 Conduct an awareness programme

WITHIN TWO MONTH

7 Establish programmes to improve water quality and waste disposal systems in high risk areas



8 Conduct a health and hygiene education campaign

9 Initiate a transmission control programme



10 Establish a monitoring system

NOTES

- 1** The coordinating committee is made up of environmental health officers, medical staff, senior government officials at permanent or principal secretary level and other relevant government and non government agencies. Form a local level committee in the area of the outbreak, with similar technical composition and including community leaders.
The purpose of the committees is to manage the interventions, gather data on patterns of disease spread, mobilize resources and get government and other funding organizations backing.
- 2** Identify areas of high risk on the basis of:
 - existing water services,
 - access to sanitation,
 - previous history,
 - proximity to the current outbreak,
- 3** Identify necessary resources and if necessary, divert human and financial resources from non critical areas and activities and focus them on the outbreak.
- 4** Ensure appropriate case management for affected people and improve drug supply and availability in the high risk areas.
- 5** Carry out sanitary surveys and take appropriate short term or temporary action to protect water from contamination in affected areas and areas at immediate risk
Check on water sources and educate communities on the need for using protected water supplies. Check on sanitary disposal systems especially in urban, peri-urban and squatter settlements.
- 6** Conduct an awareness programme aimed at all sectors of the population.
Use available means of communication including radio, newspapers and political rallies to inform people of the outbreak including what they can do to prevent further spread. Put up posters in public places such as bus stops, beer gardens, schools, churches and hospitals
- 7** Establish programmes to improve water quality, availability and waste disposal systems starting with the high risk areas. Such programmes could include upgrading or rehabilitating existing water supply points or waste disposal systems to improve their safety.
- 8** Establish and conduct a health and hygiene education campaign including the preparation and dissemination of education materials. Design appropriate participatory health and hygiene education programmes and support materials
- 9** Initiate a transmission control programme. Identify water use patterns and establish a vector control programme to minimize the frequency and occurrence of all water borne diseases.
- 10** Establish and institutionalise a long term monitoring system for both disease transmission and maintenance of water and waste disposal facilities. The monitoring and data collection system is useful in preventing repeat cholera outbreaks and also for use in planning and preparing strategies for future cholera outbreak

Reference

Facts sheets on environmental sanitation for cholera control. WHO/CWS/92.17.



**ESTIMATING REQUIREMENTS FOR WATER QUALITY MONITORING
AND CONTROL**



- 1** Sanitary surveillance forms.
Quantities required
Inspection form for each type of system - wells, springs, piped schemes etc.
Enough copies for the desired inspection frequency.

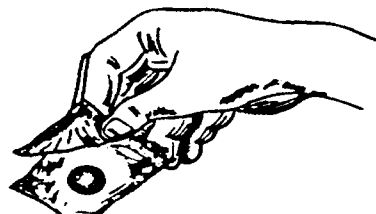

- 3** DPD tablets for chlorine analysis
Quantities required
Urban and peri-urban: 50 per comparator per week
Rural: 15 per comparator per week



- 5** Turbidity tube.
Quantities required
One per portable testing kit

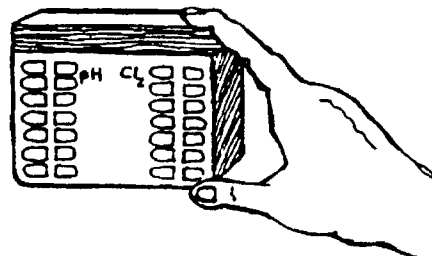

- 2** Chlorine comparator
Quantities required
Urban: 4 per 100,000 population
Peri-urban: 1 per 1,000 population
Rural: 1 per chlorination station.

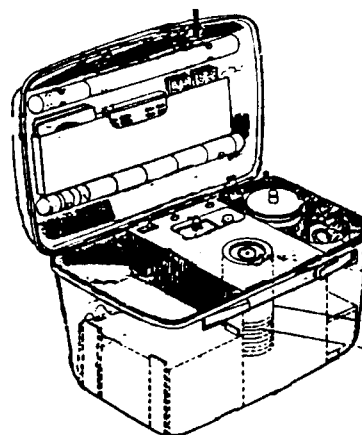

- 4** Portable water testing kit for bacteriological analysis.
Quantities required
Two kits per surveillance region
Urban and peri-urban: consumables for 30 tests per kit per week
Rural: sufficient for 10 tests per kit per week

NOTES

To prevent or control epidemics associated with water it is important to control water quality in water supplies. Water quality monitoring should take place in all water supplies, whether protected or unprotected, with the frequency and type of monitoring adapted to local experience and resource availability.

Water quality monitoring programmes should be systematic and comprehensive.

- ① Sanitary surveys are carried out using a checklist. Obvious risks to water quality should be rectified immediately.
- ② Chlorine comparators are used to check that chlorine content of treated water is at the desired level. This is only applicable to chlorinated supplies. It is a simple test which can be used to indicate whether there are any problems within the supply system.
- ③ DPD tablets are a relatively cheap and reliable way of carrying out the chlorine test. The sampling programme will determine the number of tablets required. Chlorine levels should be determined daily where water leaves the treatment plant and at selected sampling points in the distribution system.
- ④ Portable water testing kits are useful for bacteriological analysis. Large piped supplies should have a fixed laboratory for bacteriological analysis but portable testing equipment is valuable when covering several water supply systems, for large rural areas, and where transport of samples is a problem. Supply of consumables depends upon the expected number of tests (some recommendations are given in the fact sheet on COLLECTION OF WATER SAMPLES - SAMPLING). Spares for the test kit are necessary as the conditions of use are often harsh.
- ⑤ Turbidity is measured with a turbidity tube or an electronic turbidity meter. Usually this is measured at the same time as bacteriological tests are carried out. Turbidity can prevent chlorine from killing germs in the water efficiently.

Reference: WHO, 1992. Facts Sheets on Environmental Sanitation for Cholera Control. WHO/CWS/92.17



COMMUNITY PLANNING FOR DIARRHOEAL DISEASE CONTROL

- Through health education and hygiene promotion, communities can be encouraged to take action to protect themselves from outbreaks of diarrhoeal disease.
- The following steps guide a facilitator to assist the community to organise themselves and plan for action.

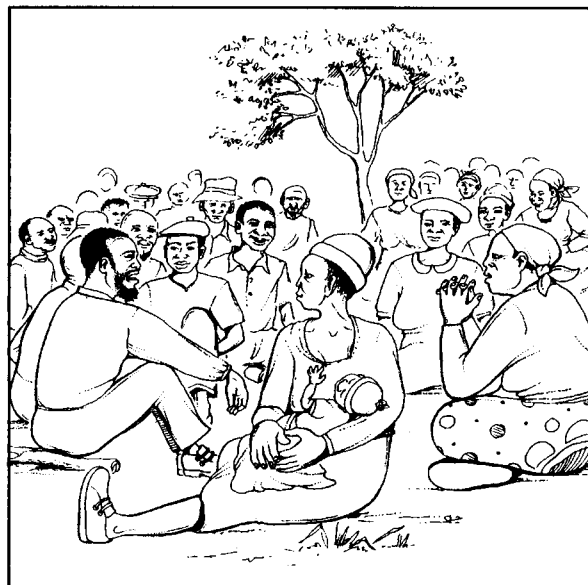

① Problem identification

Identify the priority health problems with the community and assess the importance of diarrhoea.

② Problem analysis

Community identifies the causes of diarrhoea in their own village

③ Planning for solutions

Community agree which causes they wish to address, organise themselves and develop an action plan.

④ Technical information

Community requests technical information from extension staff as a basis for further decision making.

⑤ Infrastructure

Community develops an action plan for an infrastructure project. May seek external financial and technical assistance.

⑥ Behaviour change

Community agree on behaviours that need to change within the community and agree how this will be achieved.

⑦ Evaluation and feedback

Community assess what has been achieved, what has not been achieved, and agree what to do next.

NOTES

The facilitator should have had some training in participatory methods in order to conduct these sessions. Water and sanitation technologies as well as behaviour change, should be effective, acceptable and affordable to the local community. Participatory methods recognise that communities are central in the decision making process, allow communities to make informed decisions, and encourage self help and a sense of self worth. The output of these community sessions should be an informed community taking the lead in solving its own problems. The facilitator/ extension worker should visit the community periodically to show interest in how they are performing and also when requested to provide additional information or support.

The steps shown overleaf may still be followed, but modified where appropriate, if the health priority identified by the community is something other than diarrhoea.

Participatory methods suggested for the steps shown are as follows although there are others which you may also find suitable:

- ① Nurse Tanaka. This tool uses a picture of a health facility (use the communities own clinic name) and pictures of people waiting for treatment. The pictures of people waiting for treatment can either be handed out to the community group or they can be stuck around the picture of the health facility. Community members come forward, point to a picture of a patient and state what disease may make the patient come to their clinic. The community then decides which diseases are important in their own situation. The important diseases are those which should be addressed by the health workers and this fact sheet assumes that diarrhoea is one of those selected as important by the community.
- ② Story with a gap. The story with a gap is a participatory technique stimulating discussion within the community on a process of change from one situation (first picture) to another (second picture). For the purpose of analysing the causes of diarrhoea in the community the two pictures could show: firstly a healthy child and secondly a child with diarrhoea. The discussion centres around how/ why the child became sick with a focus on their own community.
- ③ Story with a gap. The same pictures are used as before but the pictures are swapped over with the first picture of a sick child and the second of a healthy child. The discussion centres around what should be done to correct the causes of diarrhoea identified in the previous session.
- ④ Discussion group. This session provides technical information to allow the community to make an informed choice on what to do about technology. Technology options available should each be discussed including for each one: the benefits; the cost of construction; subsidy to community, if any; cost of maintenance; skills needed by the community. It is important that the extension worker is well informed for the community to be able to make decisions.
- ⑤ Discussion group. The process of planning project implementation may be a long one especially if outside support is expected for new infrastructure. Agreement should be reached on project management, number and location of facilities; financial contributions; training; operation and maintenance; time frame. The community should be allowed to assume as much responsibility as possible.
- ⑥ Hygiene safety graph. The hygiene safety graph looks at three areas of hygiene practices and allows the community to assess how well it scores in each area as a community. The three areas are:
 - from drinking contaminated water to drinking clean water;
 - from poor personal hygiene to good personal hygiene;
 - from poor environmental sanitation to good environmental sanitation.The good and bad situations are illustrated by pictures which should be appropriate to that cultural and social setting. The community uses the pictures to assess how far they are from the goal of good practice in each of the three areas. Resolutions are made to improve in those areas where the community feels it is most necessary or likely to succeed.
- ⑦ Participatory evaluation. In a participatory evaluation the community themselves carry out the evaluation and use the results to reconsider what they are doing and to replan their activities where necessary. Four steps are used:
 - first a focus on the successes of their programme and what caused those successes;
 - then the community identify the problems of their programme and what caused those;
 - thirdly they group the problems into those they can solve themselves now, those they do not understand, and those which they cannot solve;
 - finally the community decides what they can do to help the project overcome its problems and they develop a revised plan.

Reference: WHO, 1995. Community Health Planning using Participatory Methods: the control of diarrhoeal disease. draft 27pp.

Prepared in collaboration with the Institute of Water and Sanitation Development, Zimbabwe.



WELL SINKING IN NON COLLAPSING FORMATIONS

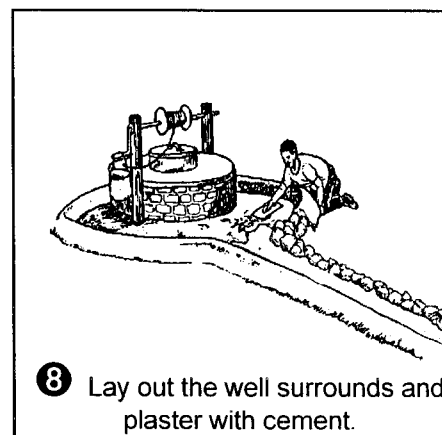
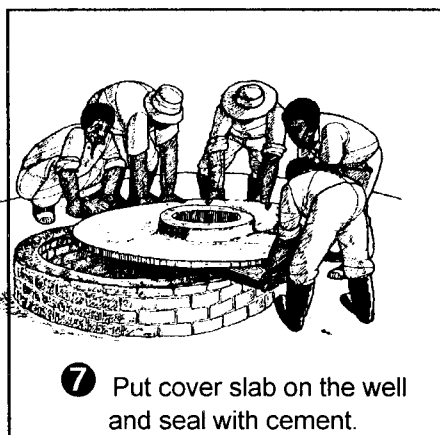
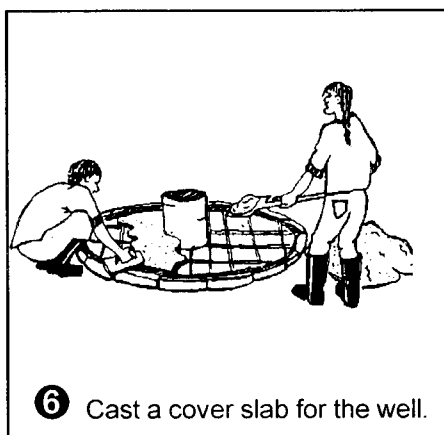
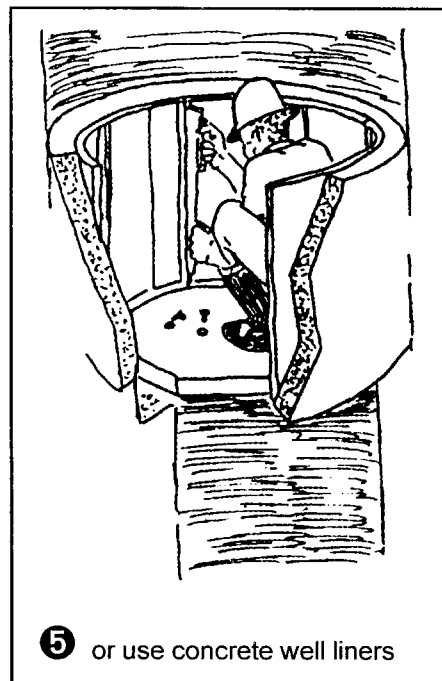
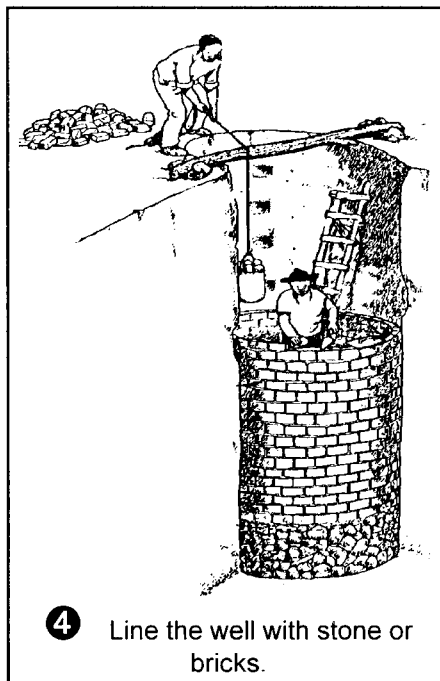
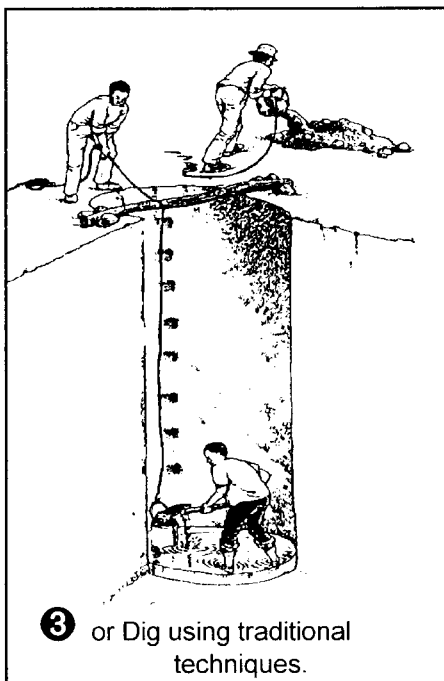
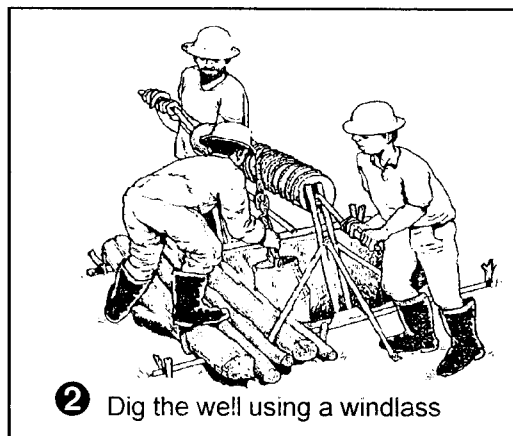
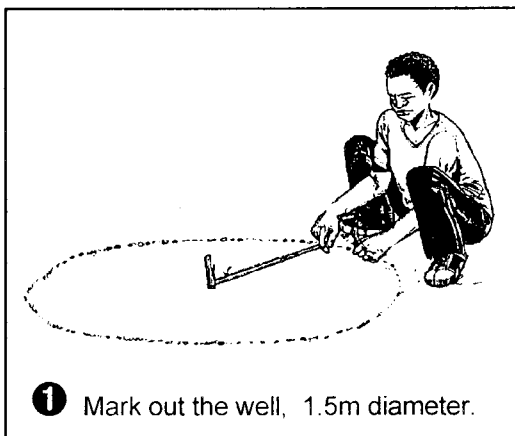

NOTES

1 The community first agrees on a site for the well. This may be a new well or it may be the upgrading of an existing well. Siting of shallow wells usually relies on local knowledge of the water table. Water availability is the first selection criteria and convenience for users the second.

Mark out a circle of 1.5m diameter at the identified site. Smaller diameter wells may also be dug especially for single family use. These are usually between 0.8m and 1 m diameter.

2 Digging should be vertical with at least two assistants on the surface and one down the well. It is an advantage if a windlass can be used to raise and lower the bucket. Efforts should be made to achieve 2 - 3 metres of water at the bottom of the well when digging during the driest season of the year.

3 Traditional skills in well sinking exist in many communities.

If hard rock is reached the diameter of the well is reduced to 1.2 m. Blasting may be required and charge holes may be drilled by hand using a 2kg hammer and 1m drill steels. Note that not all firm formations need blasting. A trained blaster sets out the explosive charges. Explosives should be lit when there is nobody in the well. Count explosions to ensure that all set charges have detonated. Do not enter the well until after a day when all gases have escaped. remove rubble and continue digging. A licensed blaster is essential for this activity.

SAFETY Well sinking can be dangerous if care is not taken. Wear a helmet when working down the well. Remove loose items from around the well head. Secure bucket, windlass and windlass supports on well. The chain and bucket should be strong not to break when full of soil or lifting a person.

4 Lining should ideally be done from the bottom to the top. In rock formations lining may not be essential and only a collar may be constructed at the first 3 - 5 m to protect the top of the well from collapse. Lining may be with rocks, bricks, concrete or precast well liners. Back filling, may be necessary where the walls are uneven. Unmortared rocks are used at the base of the well in the water table. The lining should extend at least 30cm above the ground level. This is an important factor in protection of the water quality.

5 To cast well liners in situ a working platform is lowered to where the loose formation ends. Clean and oil the smooth side (outside) of each shutter before positioning. Shutters are kept tight by the spacers (or keys) bolted between them. The gap between the shutter and the wall is filled with concrete. The shutters are removed and raised every 24h after allowing the previous ring to set. Use of concrete and shutters requires a greater specialist knowledge and is more expensive than lining with bricks or stones and mortar.

6 The cover slab is marked out on the ground with bricks so that it is big enough to cover the well lining. The marked area is covered with plastic sheet or cement bags. The slab is reinforced with a grid of 6 - 9mm reinforcing wire about 10cm apart. Cement (1 shovel cement, 2 shovels sand, 3 shovels gravel) is added to a depth of 5cm leaving a hole for the bucket or handpump to pass through. Keep damp for five days before cementing in place on the well head.

7 The cover slab is placed on top of the well and sealed in place with cement. The sealing of the well head helps to prevent contamination of the water inside the well.

8 Mark out the apron and the direction for waste water to drain. Set apron and spillway shutters and plaster with cement. A soakaway may be constructed at the end of the spillway by digging a hole and filling with rocks. A more popular alternative is to plant a small garden to receive the water.

References:

WHO, 1992. Facts sheets on environmental sanitation for cholera control. WHO/CWS/92.17
Morgan, P. R. 1990. Rural Water Supplies and Sanitation. Macmillan, 358pp.



SPRING PROTECTION

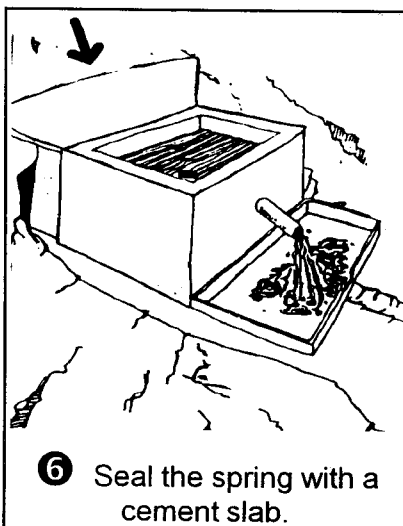
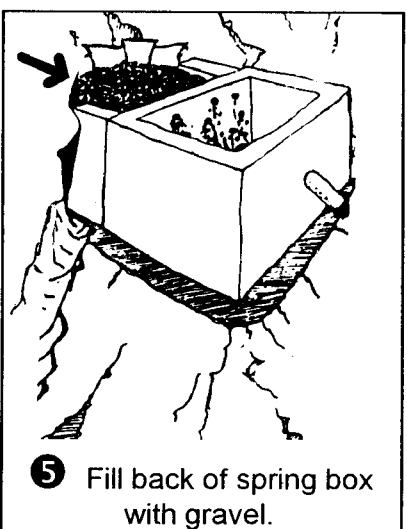
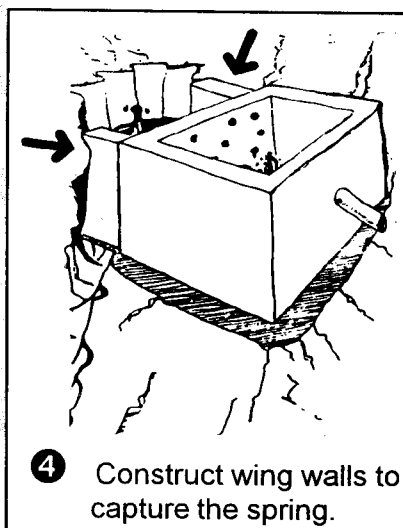
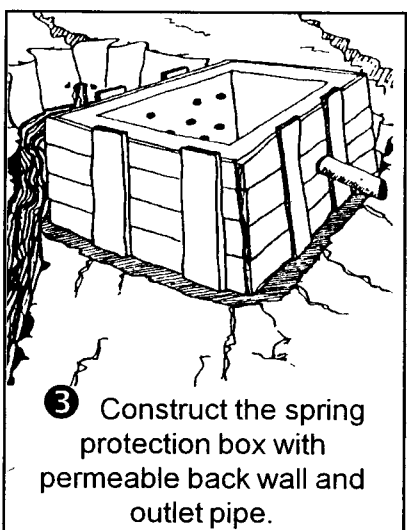
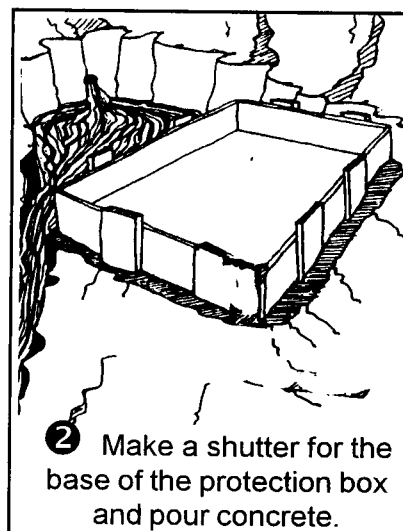
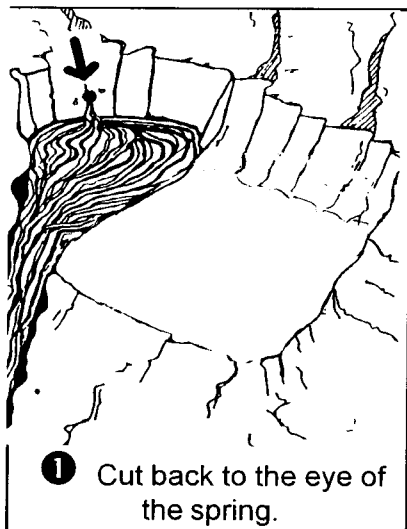

NOTES

As a first step agree with the community that the spring needs to be protected and it is culturally acceptable to do so. Check that there are no latrines or other sources of contamination such as animal pens within 30m. A favoured situation is to pipe the water a short distance away from the spring area so that the protected spring is less susceptible to erosion and damage.

- 1** Dig back until a clear point from which the spring emerges can be seen (the eye of the spring). If there are several 'eyes' either: select one for protection; protect more than one; or build a seepage collector with drains to one spring box.
Dig a temporary drainage channel which will divert the water during construction.

- 2** Use wooden shuttering and concrete (1 x cement : 4 x sand : 8 x gravel) to make the base of the spring box. The box is situated close to the eye of the spring, extends at least one metre forward from the eye and across its full width. Cure for 7 days keeping the cement damp all of the time.

- 3** Construct the protection box using local stone, bricks or concrete for walls at least 10 cm thick. Make the back wall as permeable as possible to allow water to flow in from the spring. Other walls should be plastered to make water proof. Cement mixture for concrete walls is 1 x cement : 2 x sand : 4 x gravel.
A large diameter delivery pipe is set into the wall at a level lower than the eye of the spring. The pipe should be fitted with a screen inside the box. If the water is to be piped over a long distance or fitted with a tap then an overflow pipe will also need to be fitted into the wall.

- 4** Construct wing walls to prevent water from seeping around the box.

- 5** The area between the eye of the spring and the back wall of the box should be filled with gravel.

- 6** Seal the spring with concrete or clay. A concrete apron and drain should be constructed where the water is delivered. The drain should lead into a water course as there is usually too much water for a soakaway.
Install a lid on the box. To prevent abuse it may be a heavy concrete slab or fitted with a locking device. A diversion ditch may be necessary up slope to prevent contamination or erosion from rain run off. Fence the spring area to keep animals away.

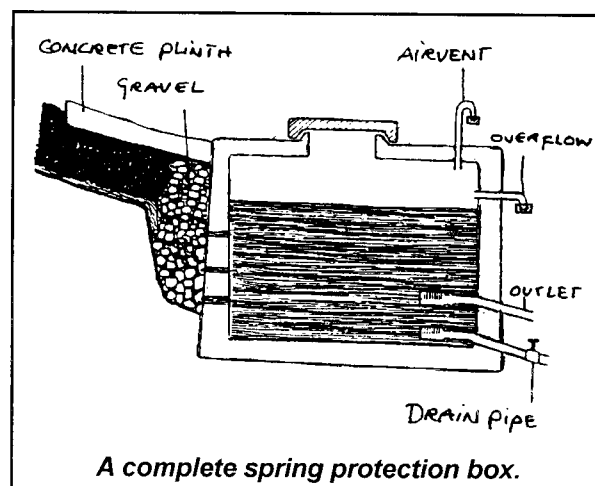

Reference

WHO, 1992. Facts Sheets on Environmental Sanitation for Cholera Control. WHO/CWS/92.17



EXCRETA DISPOSAL OPTIONS

DRY ON-SITE SYSTEMS

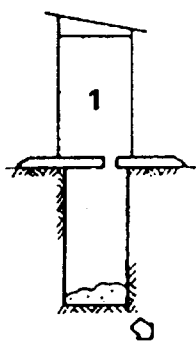

1. Pit latrine

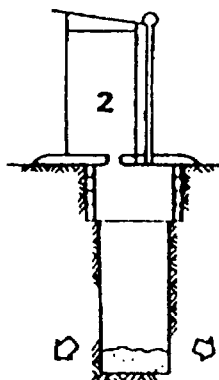

2. VIP latrine

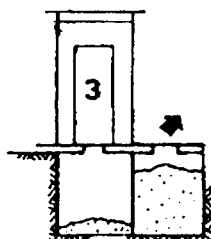

3. Twin pit latrine

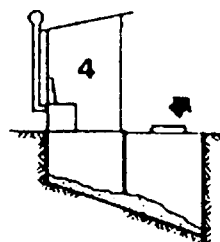

4. Compost latrine

Appropriate where water is limited to communal supplies, distance to water source is over 100m, and water consumption less than 30l per person per day.

WET ON-SITE SYSTEMS

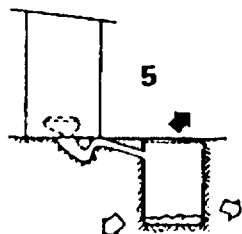

5. Pour flush latrine

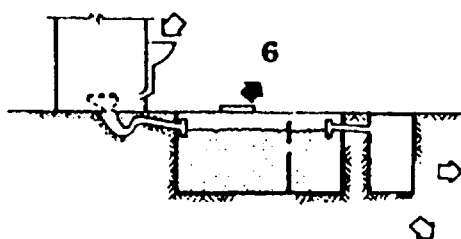

6. Septic tank and soakaway

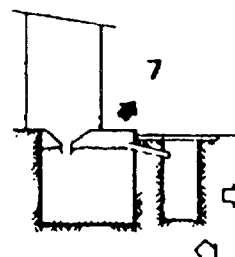

7. Aqua privy

Appropriate where anal cleansing is with water, water is available on site or within 100m. Septic tanks and aqua privies require high volumes of water for efficient operation.

OFF-SITE SYSTEMS

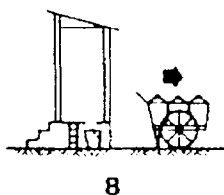

8. Bucket latrine

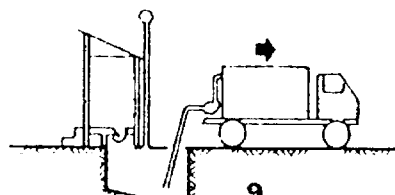

9. Vault toilet

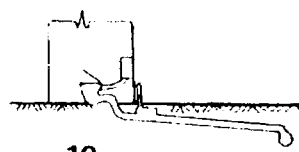

10. Sewerage

Appropriate for high population density, areas with risk of groundwater pollution, urban areas with poor water supply (bucket latrine) or with good water supply (sewerage).

NOTES

- The purpose of sanitation is to reduce or stop the spread of diseases by disposing of excreta safely and isolating it so that flies and other insects cannot reach it and it cannot get into water supplies.
 - Children's faeces also contain harmful disease organisms and should be treated the same as other excreta.
 - Safe disposal of excreta alone may not be enough to prevent the spread of cholera and other diarrhoeal diseases. Personal hygiene is very important, especially washing hands after using the latrine and before cooking and eating.
1. **Simple pit latrine** Appropriate where water is limited, usually rural areas with low population density. Problems of smell and poor acceptability can be addressed by proper slab construction with a tight fitting cover (e.g. Malawi's Sanplat); pit lining to prevent collapse and better standards of superstructure.
 2. **VIP latrine** An improved version of the pit latrine which has better odour and fly control therefore being more acceptable in medium population density situations and offering greater social and health benefits. Appropriate where water supplies are limited or unreliable and water is not used for anal cleansing.
 3. **Twin pit latrine** Appropriate in high density situations where enough land may not be available for a new pit latrine every 5 - 10 years. The second pit is brought into use while the first composts until safe to remove contents.
 4. **Compost latrine** Where reuse of human excreta is an acceptable practice. Difficult to ensure safety of compost in practice and the twin pit latrine is preferred.
 5. **Pour flush latrine** Appropriate where sufficient water is available. Controls smells and flies, allows the latrine to be inside the dwelling with an offset pit outside. Appropriate where water is used for anal cleansing. Usually flushed with a small amount of water poured by hand.
 6. **Septic tank and soakaway** Appropriate with household water supply and may receive other household waste water. The system is designed to cope with larger volumes of water than systems mentioned above and requires adequate area of land to act as a soakaway. Therefore limited in application to relatively low density urban situations. Requires access to pit emptying service every few years.
 7. **Aqua Privy** Appropriate where anal cleansing done with water. Requires constant water availability to maintain the water seal. The tank acts similar to a septic tank and must be leak proof. Generally this system is not as effective as the pour flush or the septic tank.
 8. **Bucket Latrine** A widely used system but one of the least hygienic. Usually used in high density situations where water supplies are limited or unreliable. May be used in emergency situations but disposal of the collected excreta remains a high risk area.
 9. **Vault latrine** Similar to the pour flush latrine with the waste stored in a watertight tank for 2-4 weeks when removed by a vacuum tanker. Considered a flexible option as compared with conventional sewerage but storage capacity limits water use and determines emptying frequency.
 10. **Sewerage** Requires reliable supplies of water direct to the household. The conventional system is expensive but small bore sewerage is considerably cheaper. In a small bore system an interceptor tank at the household retains the solids whilst the liquids are carried in a small diameter pipe to the sewerage system.

References

- Cairncross, S. 1988. Small scale sanitation. Ross Institute No. 8.61pp
- WHO, 1992. Facts sheets on Environmental Sanitation for Cholera Control. WHO/CWS/92.17.



SEPTIC TANK SYSTEMS FOR PERI URBAN AREAS

1 Upgradeable VIP latrine with septic tank and soakaway

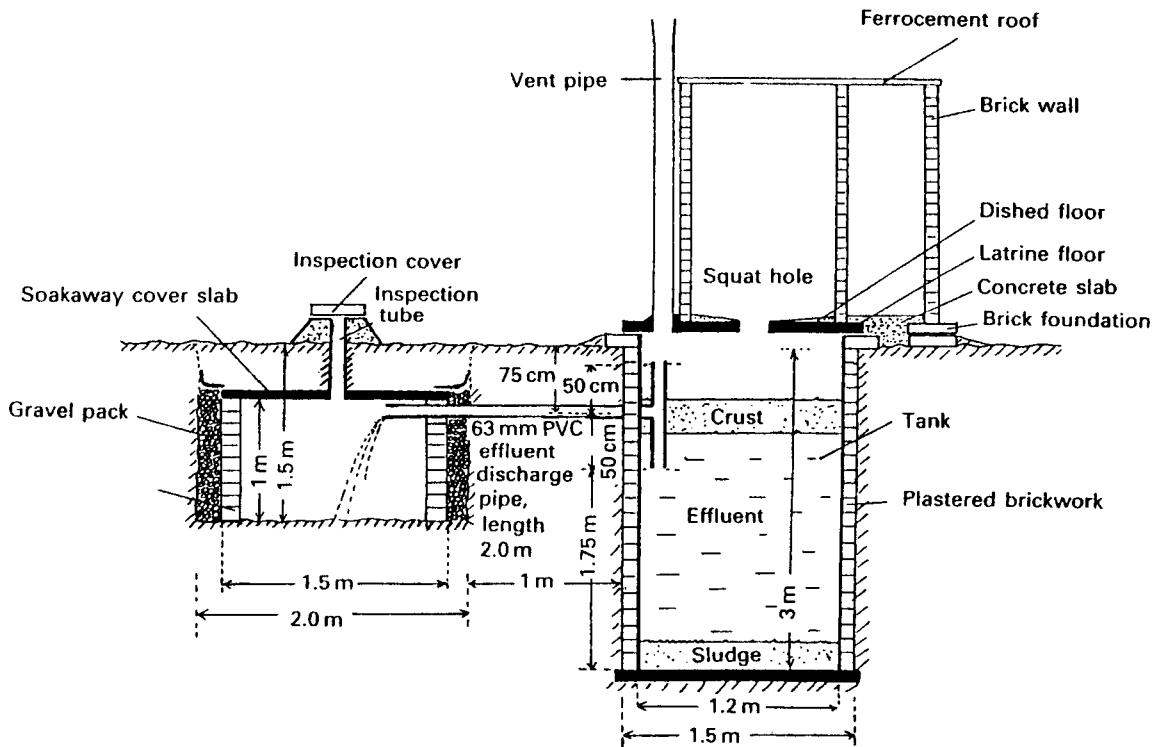

2 Septic tank and soakaway

Two compartment septic tank

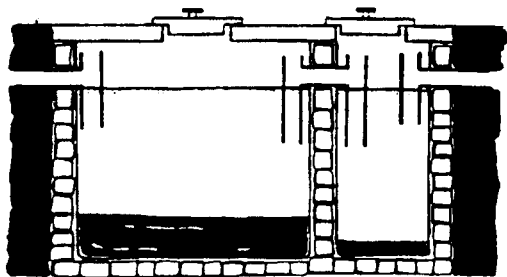

Unlined, backfilled seepage pit

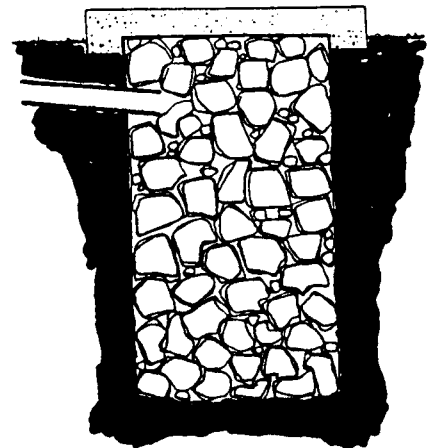

NOTES

For peri urban areas space may be a problem and a more permanent solution may be required than the traditional pit latrine or the improved ventilated pit latrine. Some options such as the pour flush latrine or the twin pit compost latrine may be suitable (see fact sheet on excreta disposal options). This sheet describes versions of the septic tank system.

In peri urban settings it may be necessary or desirable to build a latrine which is not only permanent but also upgradeable into a fully water borne flush unit. In this situation a normal pit latrine is unsuitable as it may become flooded with the additional water and it is also difficult to empty. Two options shown here are an upgradeable pit latrine and a traditional septic tank. Septic tanks are watertight chambers below ground which receive excreta and domestic sullage. The solids settle out and break down in the tank. The liquid remains in the tank for a short time before overflowing into a soakaway where it seeps into the ground. They have the advantage of low maintenance, few smell or fly problems and the possibility of later connection to a sewerage system.

1 Upgradeable pit latrine.

- Sealed septic tank overflowing into a soakaway.
- Conventional ventilated pit latrine superstructure.
- Tank can be emptied by tanker through an access cover or by removing the vent pipe
- Dimensions shown are for a family of 10 persons or less
- Tanks may be round or square.
- Materials for the below ground structure are: 10pkts cement; 1500 bricks; river sand 1m³; pit sand 3m³; gravel (12mm)1.5 m³; reinforcing wire 50m x 3mm; chicken wire 1.8m x 2m; pvc pipe 63mm class 16 3m; pvc soakaway inspection pipe 110mm class 6, 0.5m.

2 Septic tank

- Situated downhill and 30m from any drinking water source.
- Soakaway placed about 3m from the septic tank.
- Septic designed to hold about three times the volume flowing into it daily with a minimum volume of 1.5m³. An additional 30cm high space should be allowed above water level.
- A two compartment tank reduces amount of solids going to the soakaway. The septic tank has a wall dividing the tank into two parts with the first being twice the volume of the second. The two parts are joined by a pipe at the level of the outlet with T-junctions to prevent the movement of solids.
- PVC pipe 110mm is generally used for tank and soakaway connections.
- After designing the dimensions of the tank and excavation a reinforced concrete floor is constructed first. Build up the walls including the dividing wall. Incorporate inlet, outlet and compartment connector pipes in them as they are built. Walls are commonly made of reinforced concrete or bricks. To water proof the tank it should be rendered with cement mortar. Add T pieces to the inlet and outlet pipes as shown. A concrete cover slab with inspection and access holes is used to cover the septic tank.
- The liquid waste from the tank is dangerous to health and should be carried to a soakaway or drainfield where it soaks into the ground and is broken down by bacteria.
- The outlet pipe from the septic tank to the soakaway should have a slope of not less than 1:100. A typical soakaway for a family septic tank would be about 1m diameter and 2.5m deep. The soakaway may be a tank built with open brickwork or an unlined pit filled with rocks and stone as shown in the figure.
- Septic tank and soakaway systems may not be appropriate where the soil has a low permeability or where the water table is very high.

References

- WHO, 1992. Facts Sheets on Environmental Sanitation for Cholera Control. WHO/CWS/92.17
Morgan, P.R. 1990. Rural Water Supplies and Sanitation. Macmillan, 358pp.



VENTILATED IMPROVED PIT LATRINES

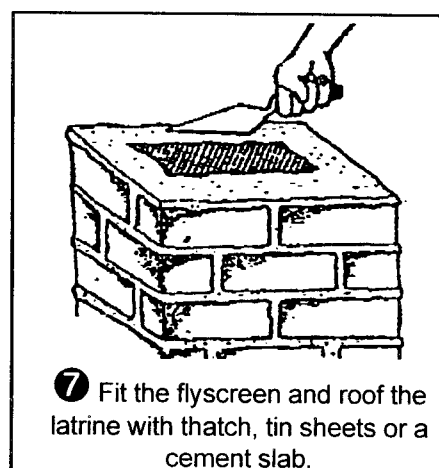
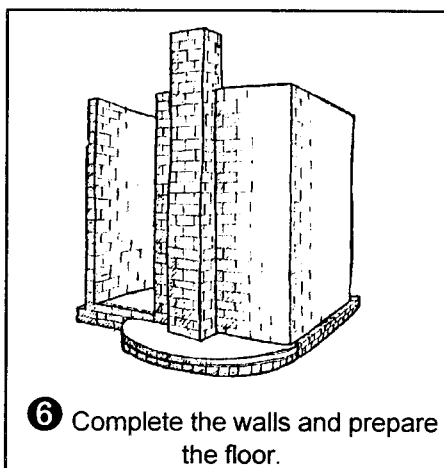
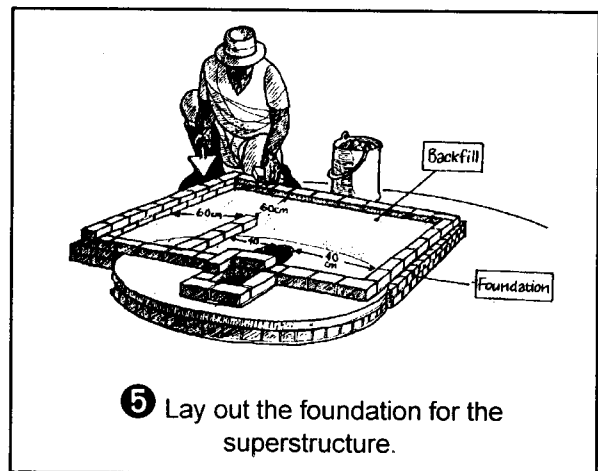
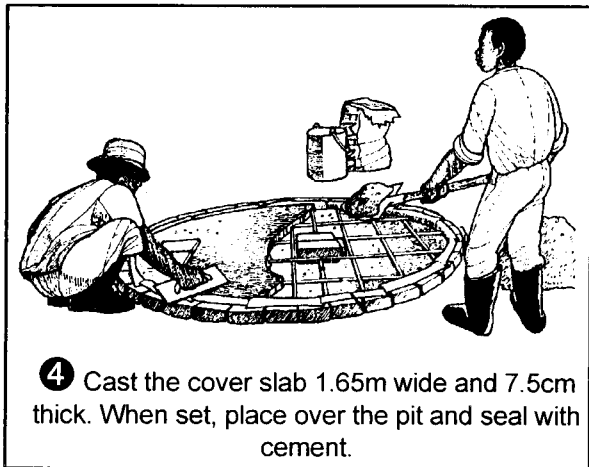
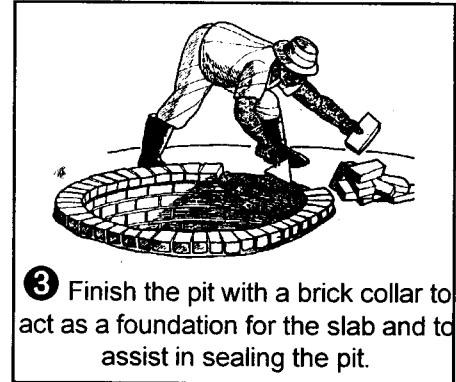
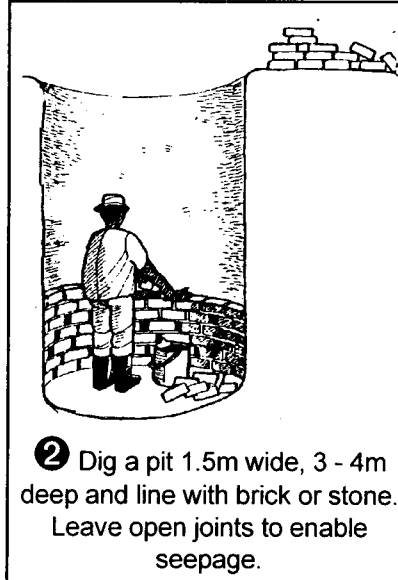
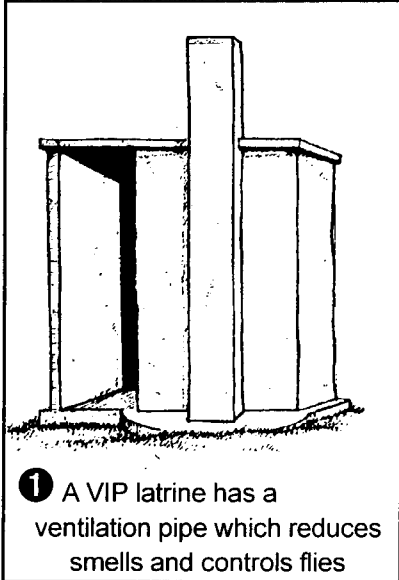

NOTES

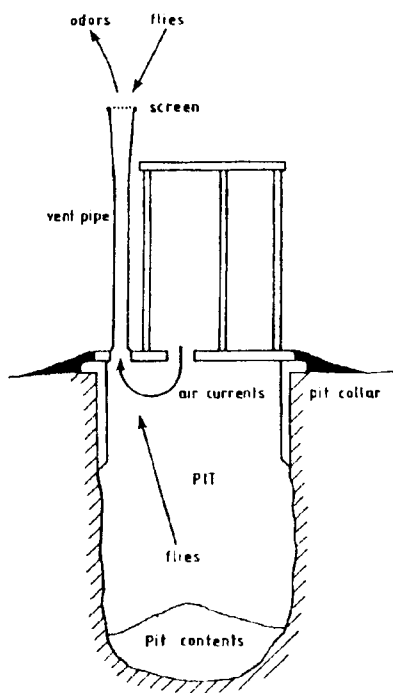

- 1** The VIP latrine allows smells to be drawn out of the vent pipe and thus is more pleasant to use than the normal pit latrine. Flies cannot enter the latrine down the pipe due to the fly screen and if a roof is fitted then any flies breeding in the pit fly up the vent to the light and are also trapped by the fly screen.

The following materials are needed to construct a single VIP latrine of brick (5 pkts cement, 2cu m sand, gravel, reinforcing wire, flyscreen) but the materials will vary depending upon how the pit is lined and the type of shelter to be built. Whilst it is advisable to build a brick vent pipe the remainder of the shelter may be of grass or other traditional building materials.
- 2** The deeper the pit the longer the latrine will last. Where soils are not deep a raised pit may be constructed and soil heaped around the walls. Lining the pit with brick or stone is advisable to prevent later collapse.
- 3** A brick collar assists in sealing the pit thus preventing entrance of flies and erosion of the pit.
- 4** The cover slab should be reinforced with 3mm wire laid 100mm apart in a grid formation. Cement mixture is 3 parts gravel, 2 parts river sand and 1 part cement. Two holes 40cm apart are left in the slab for the vent pipe (225mmx225mm) and the squat hole (150mm wide, 300mm long).
- 5** The superstructure may be made from a variety of materials and also follow local preferences. Shown here is a brick spiral superstructure which does not require a door. For ease of access the entrance should be 60cm wide and the structure 180cm high. For brick mortar use a mixture of 8 parts sand to 1 part cement.
- 6** The vent pipe should be 20cm or more higher than the roof to enhance ventilation. The floor should be made of high strength concrete (1 part cement, 3 parts river sand), which slopes toward the squat hole and is given a smooth finish with a steel float. A good latrine floor is important in controlling fouling and allowing regular washing.

A sitting structure may be added if preferred but only a loose fitting lid for the squat hole should be used (if at all) to allow the ventilation to be maintained.
- 7** A fly screen is attached to the top of the vent pipe to seal the aperture. A stainless steel or fibre glass gauze lasts longer but whichever type is used, the flyscreen should be checked regularly and replaced when torn.

References

- WHO, 1992. Facts sheets on environmental sanitation for cholera control, WHO/CWS/92.17
- Morgan, P.R. 1990. Rural Water Supplies and Sanitation. Macmillan, 358pp.
- Morgan, P.R. 1989. The Blair Latrine Builders Manual, Ministry of Health, Zimbabwe, 24pp.



RAINWATER HARVESTING SYSTEMS

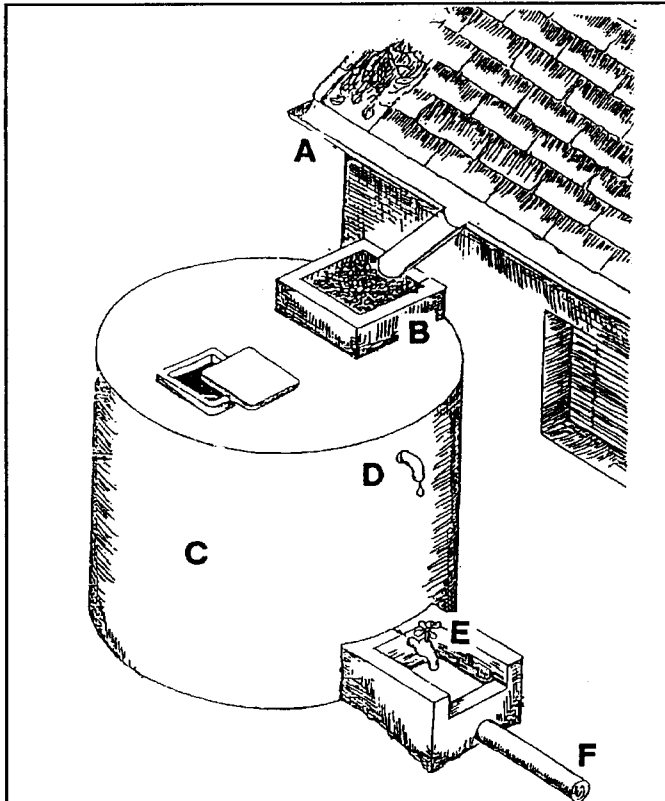

1 A typical rainwater collection system from a roof with a gutter (A) for water collection, a filter box (B) to prevent large debris entering the storage tank (C), an overflow (D), a tap for water collection (E) and a drainage system (F) for waste water.

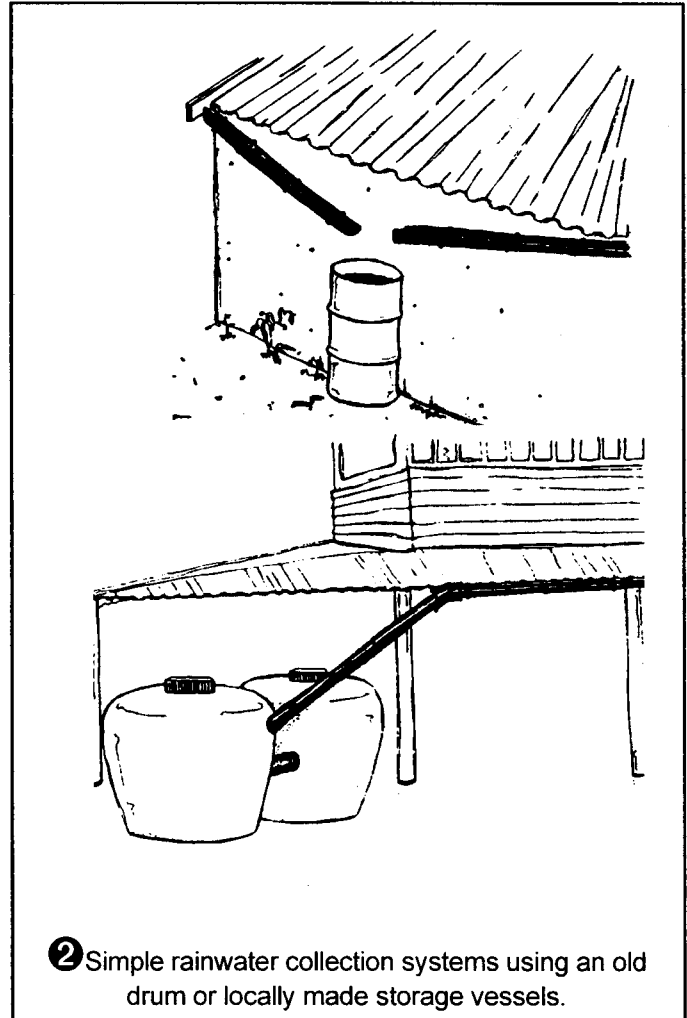

2 Simple rainwater collection systems using an old drum or locally made storage vessels.

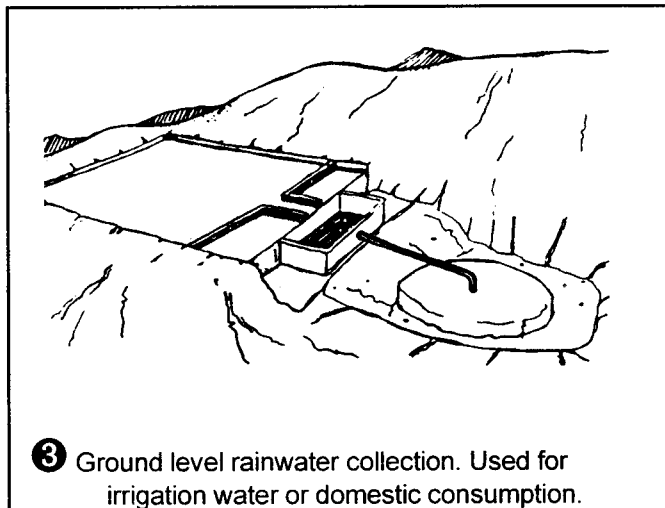

3 Ground level rainwater collection. Used for irrigation water or domestic consumption.

Three components of a rainwater collection system:

- a hard impervious surface onto which rain falls. Usually a roof or concrete slab. It is cheaper to use existing surfaces than to construct new ones.
- a storage container. In practice storage at household level is limited to a few cubic metres.
- a means of conveying water from the collecting surface and passing it to the storage vessel. Usually guttering, pipes or channels. This should include a trap or by pass to prevent solids and contamination entering the storage vessel.

NOTES

1 Where is rainwater collection appropriate? Rainwater collection is normally practised by individual households or institutions such as schools and clinics in both urban and rural situations. It can be used in areas with a year round rainfall; in areas where rainfall is seasonal and limited amounts are stored for drinking purposes in the dry season; it may also be used as a seasonal supply to provide convenient access to water during the rainy season. The practicality of the rainwater collection system depends upon the expectation of the users and the rainfall.

2 Advantages

- the quality of rainwater is high;
- the system is independent and therefore suitable for scattered settlements;
- local materials and craftsmanship can be used in construction;
- no energy costs to run the system;
- ease of maintenance;
- convenience of supply.

3 Disadvantages

- High initial capital cost;
- Water limited by collection area and rainfall, for long dry seasons the required storage volume may be too high;
- The taste of rainwater is not always acceptable.

4 Cost. Where a suitable collection surface already exists, rainwater collection can provide a safe source of water or supplement inadequate or contaminated public supplies. It is not a low cost option if there is a need to construct large storage tanks or new collecting and conveyance systems.

5 Water quality. Rainwater is of good quality but may become contaminated from the collecting surface or the storage vessel itself. The collecting surface should be cleaned periodically and if groundwater collection is used then ideally this should be fenced to protect it from animal pollution. The first rains of a wet season should be diverted to flush away any dirt, debris and animal droppings from the storage system and the filter box should be inspected and cleaned weekly. A sanitary survey by the householder should be carried out at least twice per year to identify and correct any problems.

6 Planning a rainwater collection system. Assess both social and technical information:

- how many people collect rainwater and how;
- water supply needs and expectations from a rainwater collection system;
- local opinions about rainwater quality and use;
- opinions about individual and shared water tanks;
- attitudes to expected costs and labour requirements from the community;
- rainfall records and community knowledge of rainfall;
- existing collection surfaces (e.g. tin roofs), and materials for storage vessels, guttering.

Rainfall is unpredictable but the maximum available from a collection system per year

$$= \text{mean annual rainfall (mm)} \times \text{collection area (m}^2\text{)} \times 0.75 \text{ (to correct for losses)}$$

which gives the number of litres per annum.

The estimated total demand now needs to be estimated and is usually about 15 - 30l/day per person for household use in rural areas. If supply is less than demand then possible solutions include increasing the collection area or reducing demand by limiting the use to essential activities.

7 Storage vessel. The actual amount of rainwater supplied will depend upon the size of the storage container. In areas with a definite dry season the most important reason for constructing a rainwater collection system is usually for supply during this time. The size of the tank can be determined by multiplying the demand per day by the average length of the dry season. Tank size should not exceed the expected supply from the collection area.

References

WHO, 1992. Facts Sheets on Environmental Sanitation for Cholera Control. WHO/CWS/92.17

World Bank, 1986. Information and training for low-cost water supply and sanitation. 4.1 Rainwater Roof Catchment Systems, 51pp.



AFRIDEV HANDPUMP MAINTENANCE

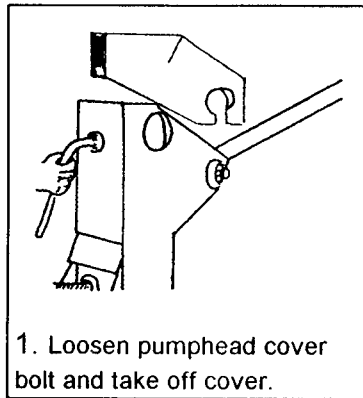

1. Loosen pumphead cover bolt and take off cover.

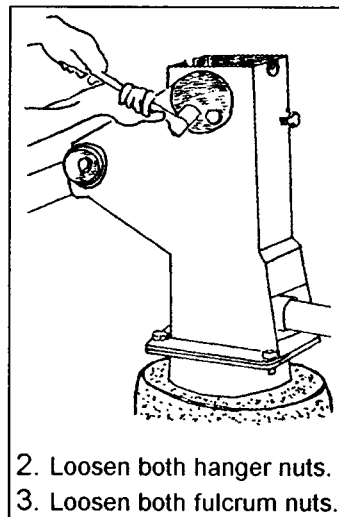

2. Loosen both hanger nuts.
3. Loosen both fulcrum nuts.

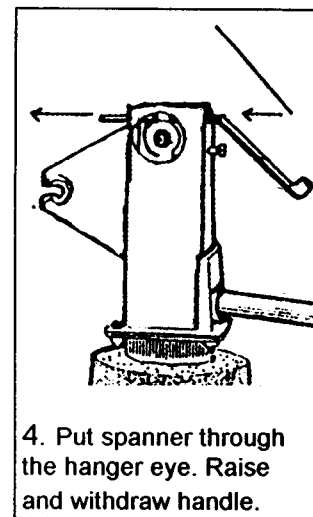

4. Put spanner through the hanger eye. Raise and withdraw handle.

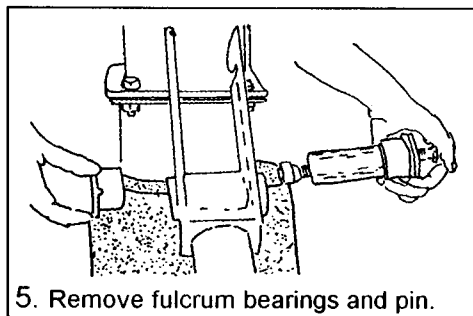

5. Remove fulcrum bearings and pin.

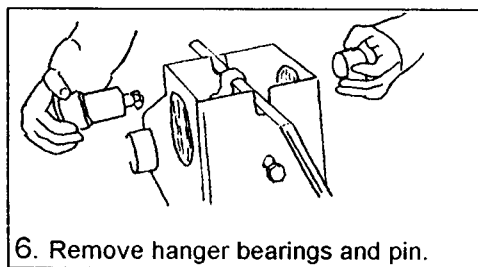

6. Remove hanger bearings and pin.



7. Pull up rods and plunger. Join rods to fishing tool and lower down the well to pick up the footvalve.

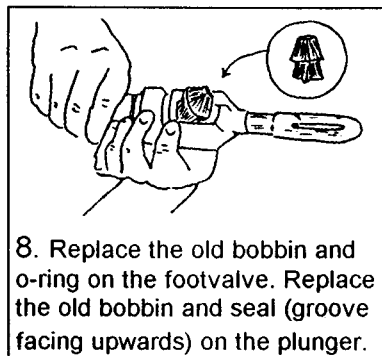

8. Replace the old bobbin and o-ring on the footvalve. Replace the old bobbin and seal (groove facing upwards) on the plunger.

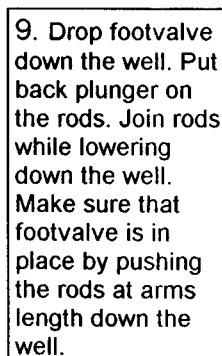

9. Drop footvalve down the well. Put back plunger on the rods. Join rods while lowering down the well. Make sure that footvalve is in place by pushing the rods at arms length down the well.

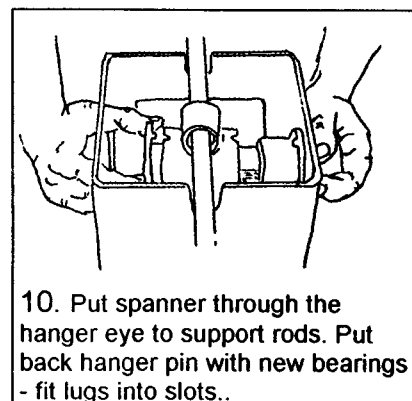

10. Put spanner through the hanger eye to support rods. Put back hanger pin with new bearings - fit lugs into slots..

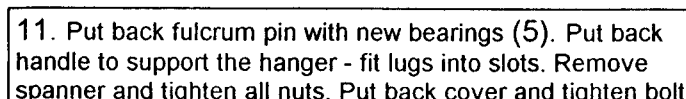

11. Put back fulcrum pin with new bearings (5). Put back handle to support the hanger - fit lugs into slots. Remove spanner and tighten all nuts. Put back cover and tighten bolt

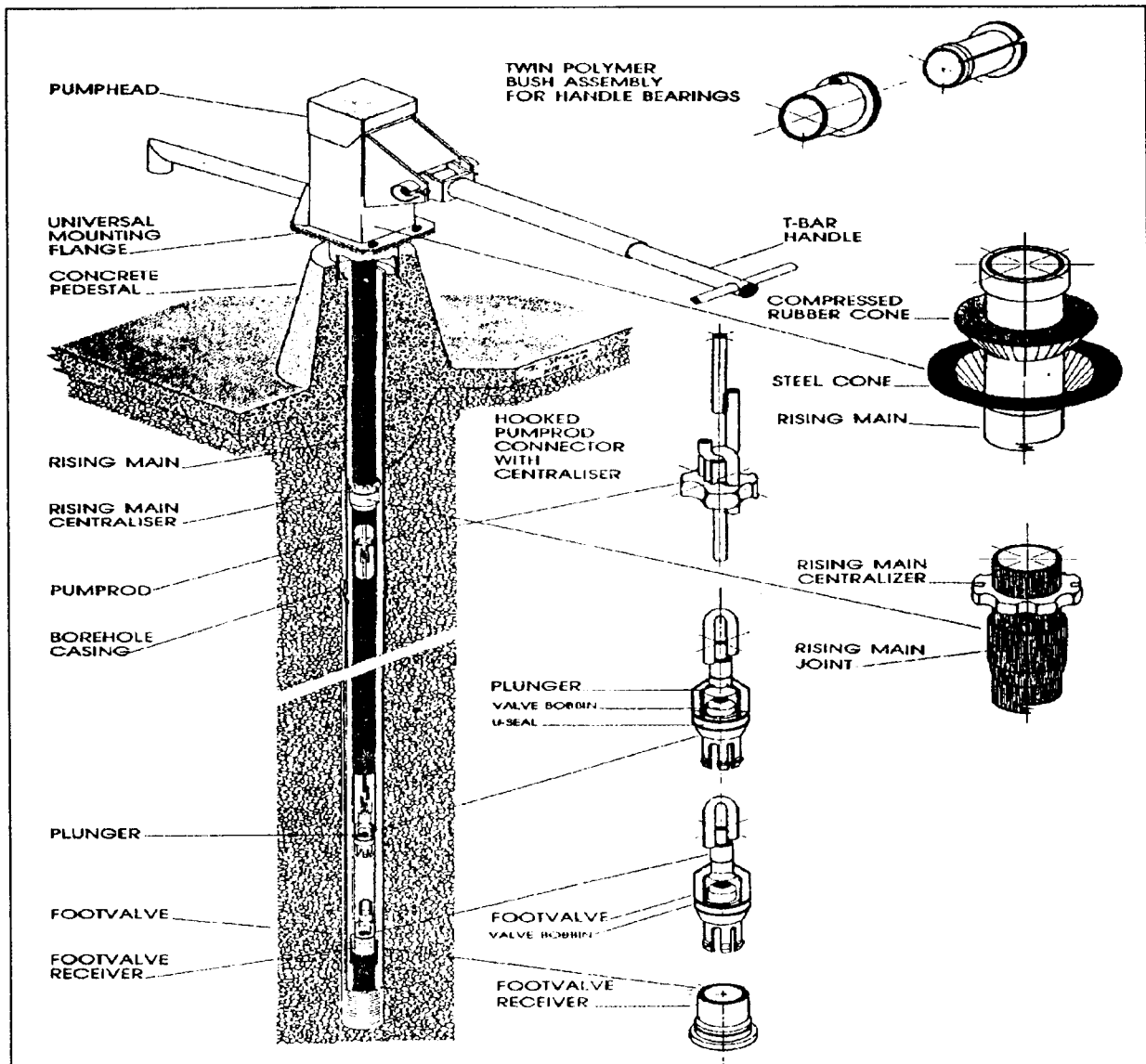

NOTES

- The AFRIDEV is designed for simple maintenance using few tools.
- Nuts are designed to be loosened but not removed to reduce the risk of losing them.
- Scheduled maintenance should be carried out at least once per year to ensure long life for the pump.
- The only tools required for the pump are the spanner and the fishing tool.
- All rods and pins should be washed before replacing.
- Keep all parts clean by storing in the pumphead cover while repairing the pump.
- Make sure that the plunger seal is replaced correctly with the groove facing up.
- Make sure that the foot valve is dropped in the right way up.
- Replace worn rods when necessary.

Reference

The AFRIDEV handpump. Scheduled maintenance. Kwale Water and Sanitation Project, Kenya.

Prepared in collaboration with the Institute of Water and Sanitation Development, Zimbabwe

Prepared in collaboration with the Institute of Water and Sanitation Development, Zimbabwe



REPAIR OF MODEL "A" BUSH PUMP

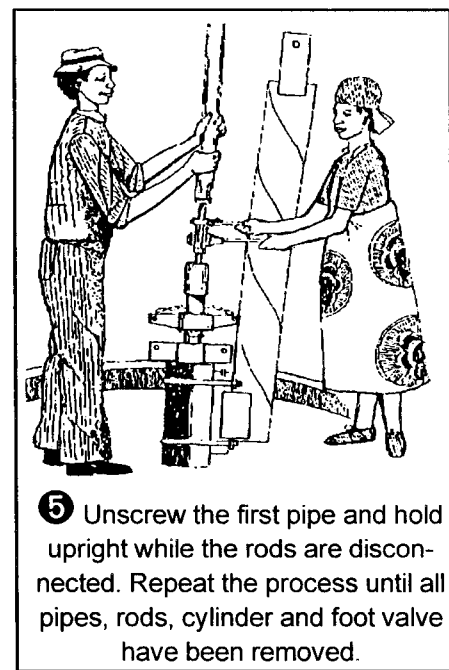
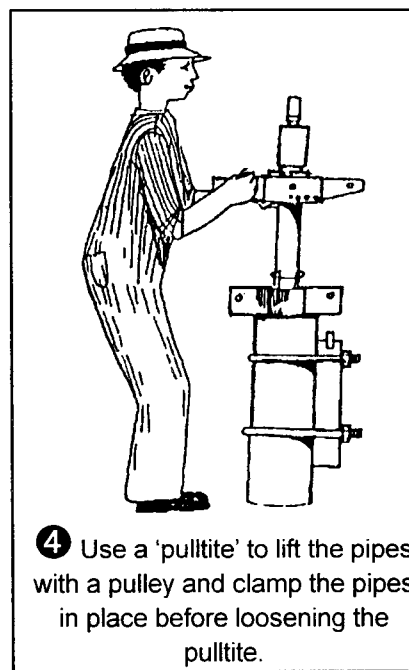
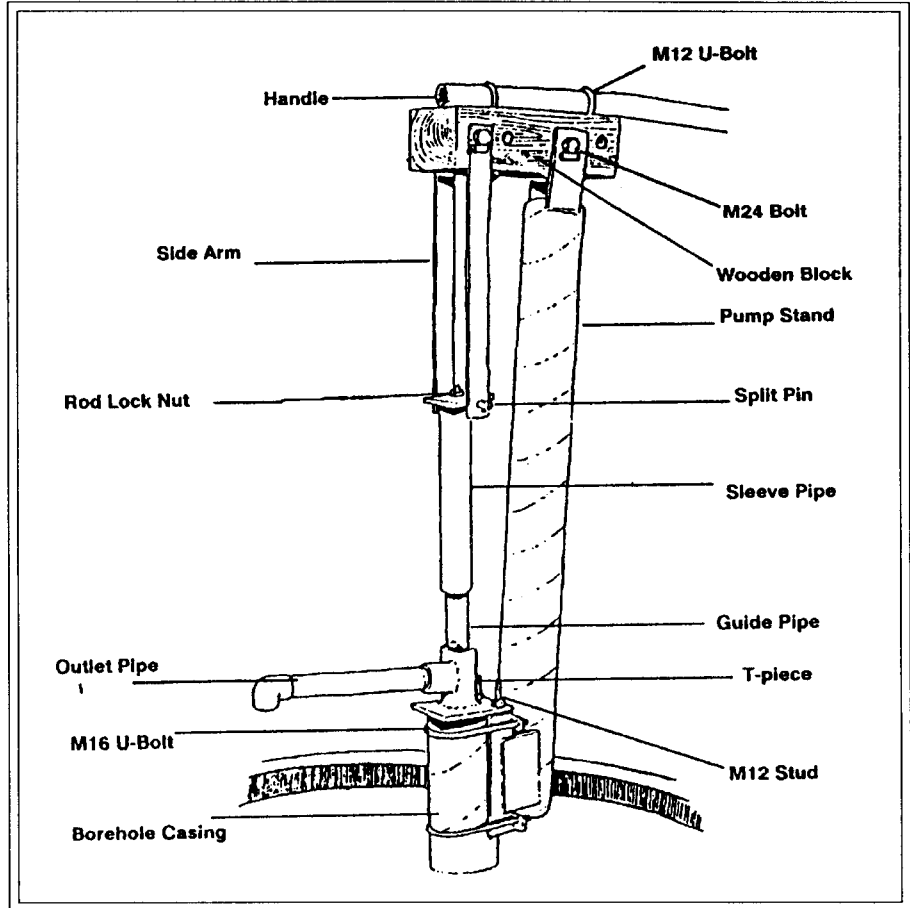
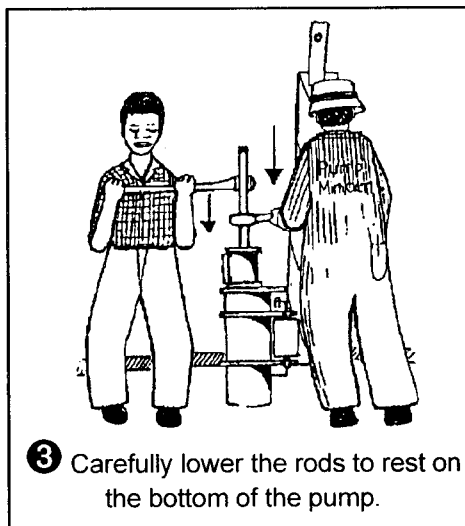
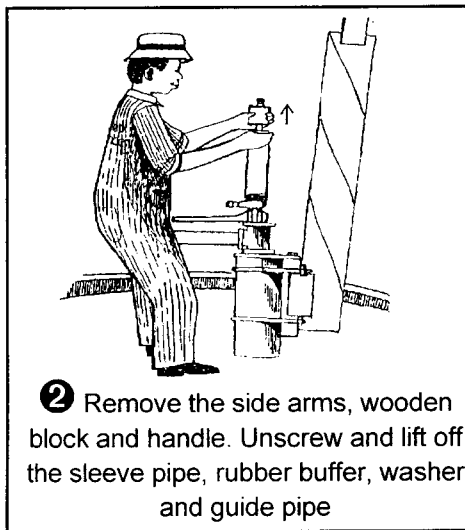
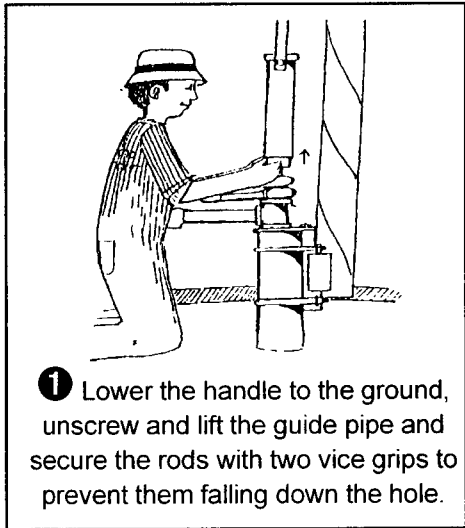

NOTES

- The correct tools should be at hand before attempting to extract a pump including spanners, wrenches, oil, Pulltite, pipe vice, shear legs and pulley.
- Carry out a pump test to identify the faults. This helps you to prepare tools to use and identify which part of the pump to attend to.

1 Unscrew the guide pipe to allow the rods to be secured before removal of the locknut and sleeve tube. Remove the bracket arms from the sleeve tube by taking out the split pins and pulling the arms gently apart. Loosening the M24 bolts allows the removal of the handle assembly and repair if necessary.

2 Unscrew and lift off the sleeve pipe, rubber buffer, rubber buffer washer and guide pipe replacing worn parts as necessary.

3 Carefully lower the rods until the plunger rests on the check valve cap in order to allow easy removal of pipes together with rods to avoid damaging the plunger. Unscrew the outlet pipe to give more working space when lifting pipes.
Set up shear legs or a tripod with a pulley over the pump to lift the pipes.

4 Attach a lifting swivel to the pipes or screw on the guide pipe and use a pulltite lifter. The M12 studs on the T-welded base plate should be loosened to allow removal of the rising main. When lifting by hand with the pulltite or using a pulley mounted on shear legs, take care that the pipe is correctly gripped. Always ensure the pipe clamp is tight before loosening the lifter. Firstly raise pipes to a reasonable height that will allow the unscrewing of the T-welded base plate.
Continue with a raise and clamp action until the first socket appears 30cm above the casing. The pipe is then clamped below the socket. The pipes may need loosening in the socket by tapping the socket with hammers. Using one stilson wrench on the socket, use a second one to unscrew the pipe above.

5 When the top pipe has been unscrewed completely, push it up to expose the connection between the rods. Disconnect the rods.
Repeat this procedure until all pipes, rods cylinder and foot valve have been removed.

- Check rods and pipes for damage or wear, cleaning with a wire brush will help expose concealed damage. Check the pump rods to make sure they are straight and the socket and lock nut are in good condition. Replace damaged parts where necessary.
- To make assembly easier and to avoid damage to components keep all sockets and threads clean and off the ground.
- Carry out a test of the functioning of the cylinder and footvalve before dismantling it and again on reassembly to identify any faults.
- Take care with the brass cylinder as it is easily damaged. Dismantle the cylinder and plunger cleaning out all sand and replacing the leather cups. Reassemble the piston making sure the correct length of the pump rod is screwed into the valve cage correctly and that its locknut is tightened in such a way that the poppet valve operates freely. If the leather cups are too tight for the cylinder use a rasp. Oil is used to lubricate the plunger. Reassemble the pump going back through the above steps.

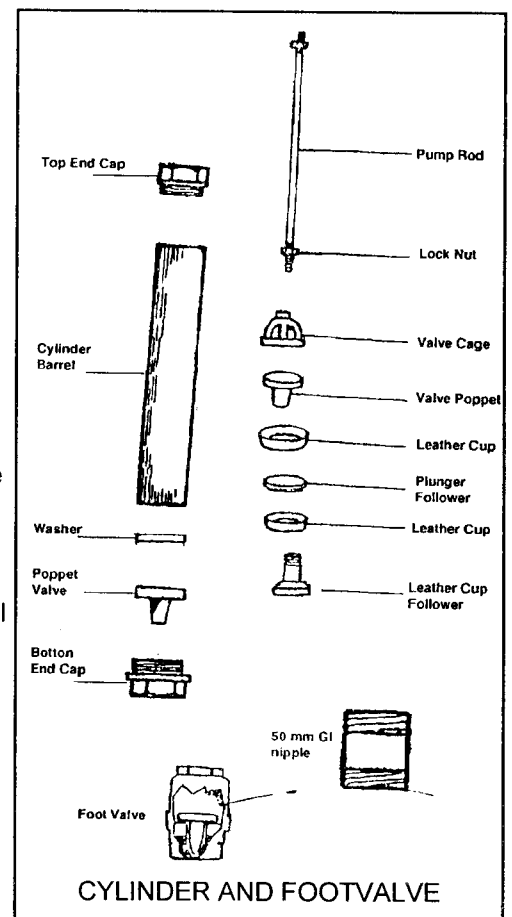

Reference

Handbook for Bushpump maintenance and repair. Govt of Zimbabwe, NORAD, UNICEF, 62pp.



HOUSEHOLD WATER TREATMENT AND STORAGE

KEEP WATER CLEAN

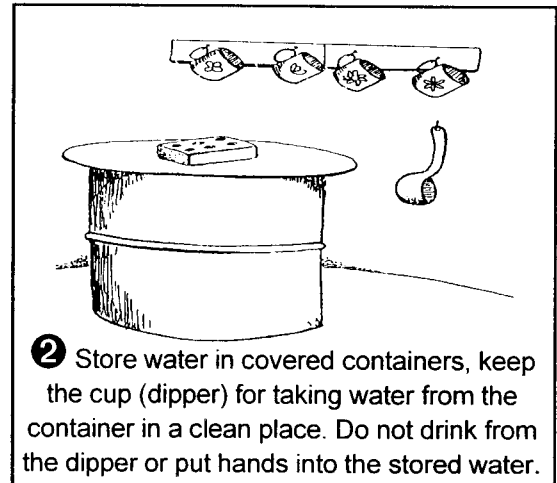
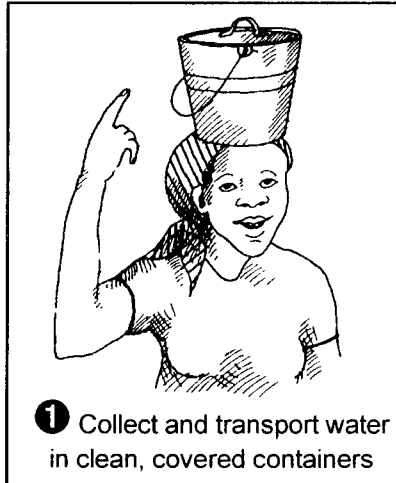

WATER TREATMENT

If your source of drinking water is not protected:

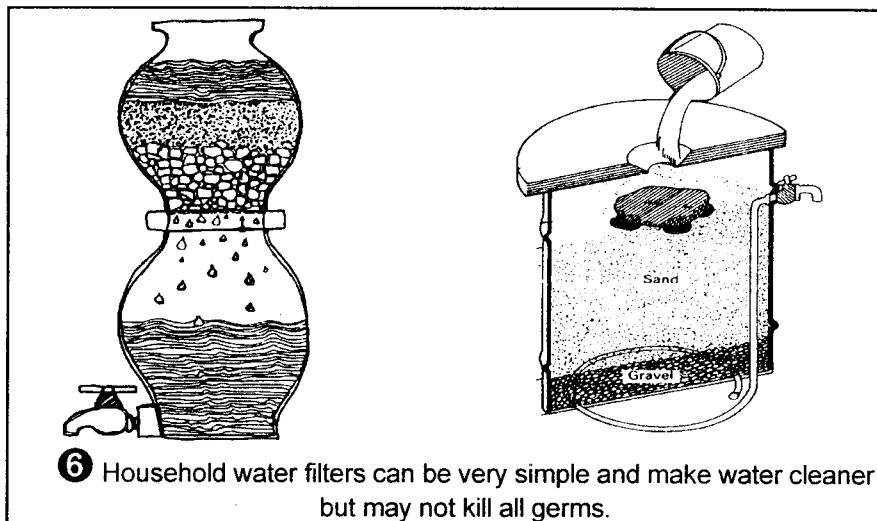
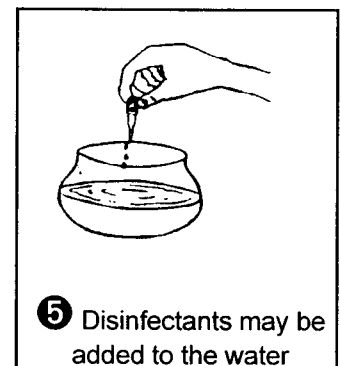
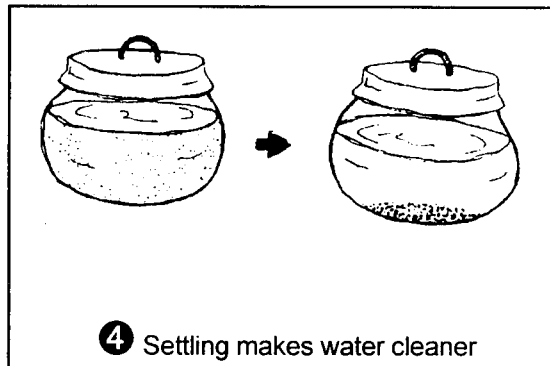
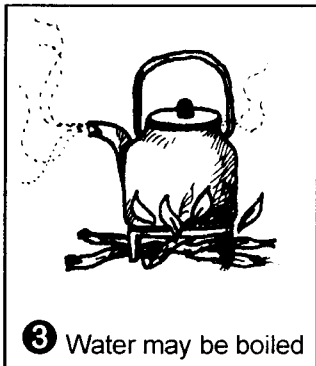

NOTES

- 1** When water is collected from a protected source it should be kept clean during transport and storage and thus will need no further treatment. Storage containers should be kept clean and covered, and the dipper should be kept on a hook nearby.
- 2** When water is collected from an unprotected source such as a river or an unprotected well it may be contaminated. The water should be treated if:
 - there is obvious contamination;
 - there is an outbreak of cholera or some other diarrhoeal disease;
 - you suspect contamination and wish to provide maximum protection to the family.Once treated it needs to be kept clean to avoid re-contamination.
- 3** Boiling is a simple way of killing germs but uses a lot of fuel. Water can be boiled while doing other cooking and saved for later use. Heating without boiling e.g in the sun can still kill many germs, but not all of them, and if water is exposed to the sun in a glass bottle the sun's rays will kill even more germs.
- 4** Muddy water can be made clearer by allowing it to settle for 4 - 24 hours. If left for as long as 48 hours many germs may also be killed.
- 5** Disinfection is carried out by adding three drops of 1 percent chlorine solution to each litre of water. The water is then left for 20 minutes for the disinfectant to work. It is important to use the correct amount of chlorine as too little will not kill all of the germs present and too much may make the water unpalatable. Chlorine does not work well in cloudy or dirty water which should be filtered or allowed to settle before disinfection.
- 6** Filtration can remove obvious dirt from water and many germs. There are many different designs of household filters. A "straight through" filter mainly removes silt and few germs whereas filters which prolong the contact of water with the sand are more effective at also removing germs (Fig 6). Filtered water may still need to be boiled or disinfected to ensure all germs have been removed.

To make a filter use a local design or copy one shown here. Collect enough small stones up to 1cm diameter to fill the bottom 7-10cm of the container; collect clean river sand, wash it well and put on top of the gravel. Water may not be clear when the filter is used for the first time and the first filtered water should be discarded.

Eventually the filter will block. When the filter no longer produces enough water, remove most of the sand from the filter, replace it or wash it thoroughly in clean water before putting it back. Blockage can be reduced by allowing very dirty water to settle first before filtering.

References

- WHO, 1992. Facts sheets on environmental sanitation for cholera control, WHO/CWS/92.17
- Morgan, P.R. 1990. Rural Water Supplies and Sanitation. Macmillan, 358pp.
- Ministry of Mineral Resources and Water Affairs, Botswana, 1985. Keep the Water Clean, Water Hygiene Handbook, 49pp.



DISINFECTANTS

WHY DISINFECT?

Disinfection is carried out to destroy disease causing organisms which may be present in the water.

Physical methods of disinfection

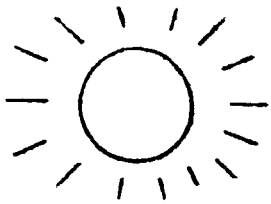

1 Exposure to the sun, either by heating the water or ultraviolet radiation, kills germs



2 Boiling water vigorously for at least 1 minute

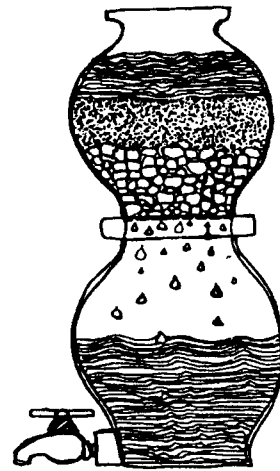

3 Filtration at family level or at a treatment works. Slow sand filtration is preferred for disinfection.

Chemical methods of disinfection

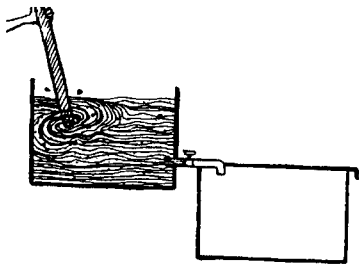

4 Chlorination with liquid bleach, powder or chlorine gas. Most commonly used disinfectant which can remain effective in water after application. Applied at 0.5 - 1.0 mg/l.



5 Iodine, similar to chlorine in effect, but more stable in storage. Two drops of 2% solution per litre clear water for disinfection.

6 Ozone, applied as a gas, does not leave a residual in water.

NOTES

Water disinfection

Disinfection of water is an important step in controlling water borne disease like cholera, typhoid and many diarrhoeal diseases. There are many other routes for the spread of these diseases and therefore water disinfection is usually linked to improved water supply, sanitation and hygiene education.

When implemented, water disinfection should be constant but to reduce the risk of disease attention should also be given to improving the quality of the source water through source protection and water treatment.

After disinfection water may be re-contaminated during water collection, storage or handling in the home.

Disinfectants

Physical disinfectants are treatments like boiling or filtration applied to the water which is then safe to drink but they have no residual benefit. Some chemical disinfectants remain in the water after application and can protect against re-contamination.

1 Sun The sun's rays contain ultraviolet radiation which has been used for disinfection of small community water supplies. Ultraviolet has been most effective when the radiation has been artificially generated but the system is expensive and the water must be of high clarity. The sun has more often been used to heat the water and provide a very limited degree of disinfection this way.

Not a very effective method, used at household level, cheap, no residual effect.

2 Boiling Boiling is a simple way of disinfecting water but uses a lot of fuel. Boiled water has an unpleasant taste unless allowed to re-aerate for several hours. Water should be brought to a rolling boil for two or three minutes or even longer if the water is not clear.

Effective but with no residual effect, used at household level, high fuel requirement, useful for emergencies.

3 Filtration May be considered a method of disinfection but differs in that germs are removed rather than inactivated. Removal of all germs by filtration may not be complete and therefore filtered water is often also disinfected. Slow sand filters are used in water treatment for large water supplies, sometimes as the only treatment, but they require a constant flow of water for maximum effectiveness. Small systems are also designed for household use.

Effective if well designed and operated, suitable for large and small scale application, no residual effect, household systems may be installed relatively cheaply.

4 Chlorine An effective disinfectant where the water is not turbid and the water is not alkaline. Filtration may be necessary to remove turbidity. Chlorine may be applied as a liquid, a powder or a gas. In all cases care must be taken as chlorine is dangerous. Large scale systems mainly use chlorine gas whereas smaller ones use powder (Calcium hypochlorite). Household disinfection mainly uses liquid bleach (Sodium hypochlorite). Chlorine remains in water and has a residual effect thus reducing the risk from new contamination of the water. Thus excess chlorine is usually added to ensure the residual levels are maintained. Chlorine is easy to measure and so the safety of water can be readily determined by measuring the chlorine level.

Most commonly used disinfectant, cheap, residual effect, suitable for household and large scale use.

5 Iodine is similar to chlorine in its action and is more stable in storage. Its higher cost reduces its use in large scale water supplies. Its stability and availability in tablet form make it suitable for personal disinfection and for use in emergencies.

Relatively expensive, effective, residual effect, useful for small scale personal use.

6 Ozone Unstable gas only slightly soluble in water. As it is unstable it does not persist and therefore has no residual effect. Assists in removing tastes and odours. Ozone is manufactured on site and is only suitable for large treatment plants. More expensive than chlorine.

Large scale use, no residual effect, expensive, efficient.

Reference: WHO, 1992. Facts Sheets on Environmental Sanitation for Cholera Control. WHO/CWS/92.17



CLEANING AND DISINFECTION OF WELLS

WHEN TO DISINFECT

Protected well
pollution believed to have occurred

Unprotected well
disease outbreak;
pollution believed to have occurred

MAKING THE DISINFECTANT

Product (% by weight available chlorine)	Amount for 0.2% solution
Calcium hypochlorite (70%) <i>or</i>	60 grams in 20l water
Bleaching powder or chlorinated lime (30%) <i>or</i>	132 grams in 20l water
Sodium hypochlorite (5%) <i>or</i>	1l in 20l water
Sodium hypochlorite (10%)	440ml in 20l water

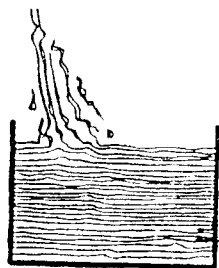

take 20litres of water

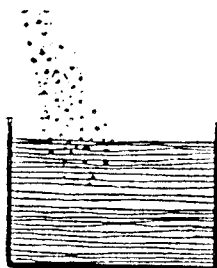

add required amount of chlorine

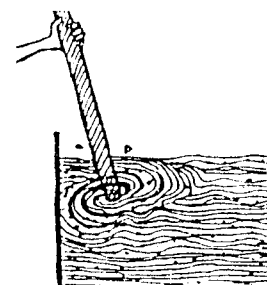

mix well

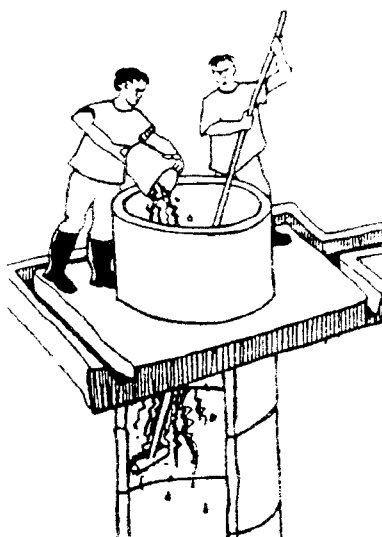

DISINFECTING THE WELL

- scrub the inside walls with chlorine solution
- clean any pumping system
- add 40l chlorine solution to well

NOTES

WHY DISINFECT?

Disinfection is carried out to destroy disease causing organisms which may be present in the well.

WHEN SHOULD WELLS BE DISINFECTED?

Protected wells. Wells are considered "safe" if they are covered to prevent contamination getting into the well from the surface. These wells should only need to be disinfected if:

- it has just been constructed or work has been carried out on the well;
- there is reason to believe that contamination has been introduced to the well; or
- a sanitary inspection shows a pollution risk.

Unprotected wells.

Disinfection may be necessary in the event of a disease outbreak or if there has been a case of obvious contamination. An unprotected well is always at risk of contamination. As a short term measure it may be possible to disinfect the well every day but it will be much cheaper in the long run to protect the well properly.

In all cases the cause or risk of pollution should preferably be attended to before proceeding with the disinfection.

Contamination through the soil from latrines or animals is rare unless the source of pollution is close to the well (a minimum of 30m is recommended). If this is suspected as the only possible source of contamination it may be necessary to close the well or remove the source of contamination otherwise disinfection will be required on a daily basis.

MAKING THE DISINFECTANT

Chlorine is the most common disinfectant available and will be used as the example here.

Normally a 0.2 % solution of chlorine is made up using either Sodium hypochlorite (liquid bleach) or Calcium hypochlorite (white granules).

Mix the disinfectant with the water and let it settle for for an hour.

Decant the clear liquid and use this to disinfect the well.

DISINFECTING THE WELL

Make up about 40l of 0.2% chlorine solution.

Use a brush on a long handle to scrub the inside walls and any pumping systems in the well with the solution.

Pour any remaining chlorine solution into the well. Mix up another 40l of 0.2% solution and also pour that into the well.

If there is a pump then pump until chlorinated water starts to come out.

The well should be left for 24 hours.

If possible a bacteriological test should be done to check if the water is safe to drink after disinfection.

After 24 hours the well may be used as normal although it may be preferable to pump out water until the smell of chlorine is no longer offensive.

Most contamination of well water occurs from the surface and so to prevent contamination occurring again through the life of the well it should be regularly subjected to a sanitary inspection.

Reference: WHO, 1992. Facts Sheets on Environmental Sanitation for Cholera Control. WHO/CWS/92.17



DOSING WATER WITH HYPOCHLORITE SOLUTIONS

HYPOCHLORITE SOLUTIONS

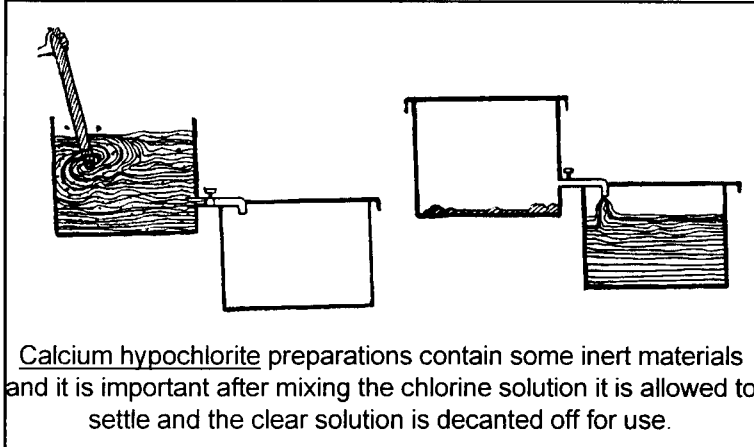

Sodium hypochlorite is a solution (liquid bleach) which only requires dilution to an appropriate concentration (2% available chlorine).

Calcium hypochlorite preparations contain some inert materials and it is important after mixing the chlorine solution it is allowed to settle and the clear solution is decanted off for use.

CONSTANT-HEAD CHLORINATORS

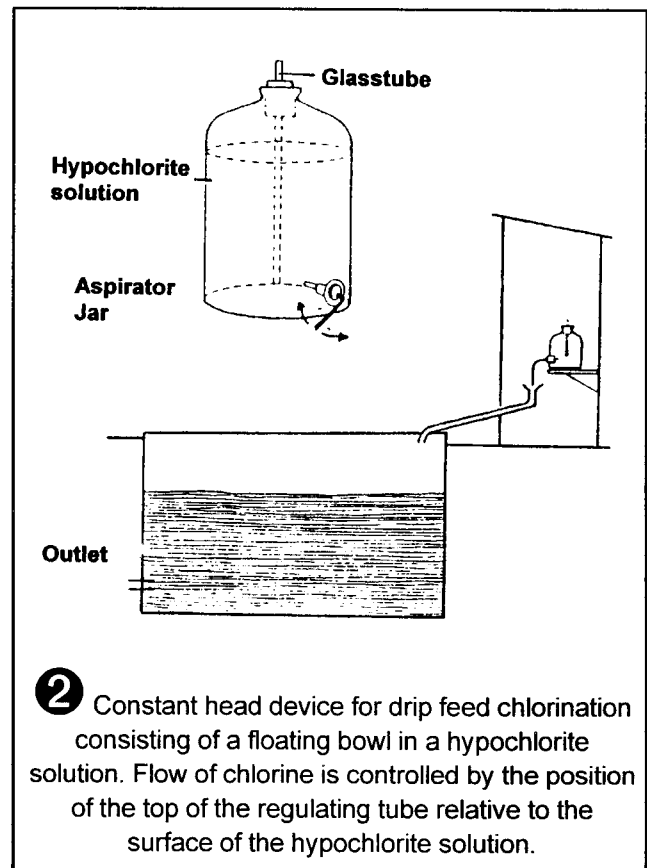
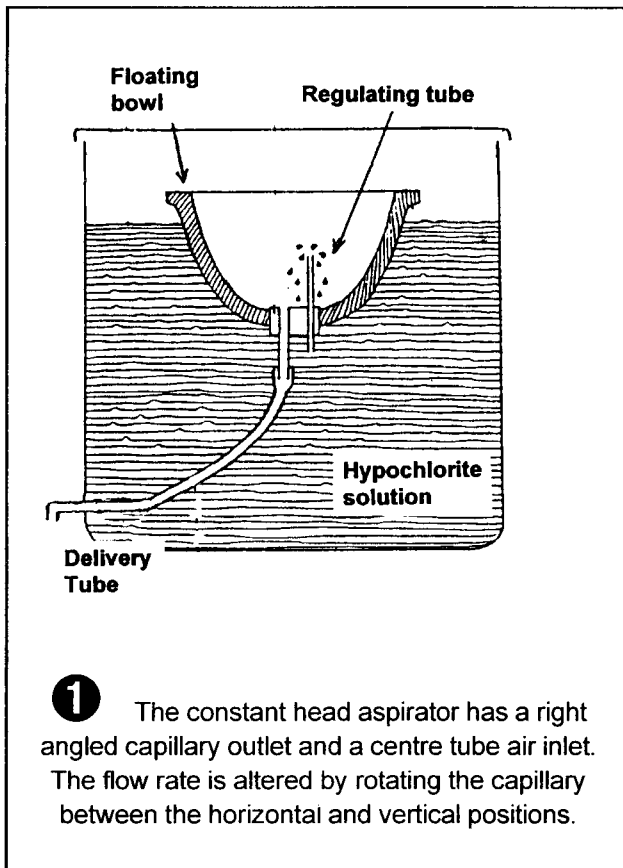

NOTES

Disinfection

- Hypochlorite solutions are used to disinfect drinking water in order to kill or inactivate pathogenic organisms. Disinfection should be constant as long as the risk of contamination exists. Hence the desire to use reliable dosing systems.

Hypochlorite dosing

Systems for hypochlorite solution dosing have three major components:

- solution preparation.
- flow control.
- application
- Solution preparation is simple with sodium hypochlorite (liquid bleach) which only requires dilution to 2% available chlorine and is ready for immediate use. Calcium hypochlorite comes as a white powder, needs to be dissolved in water and then allowed to settle as it contains inert components which could block flow systems if not removed. The clear solution is then decanted for use. Solutions are normally made up and left overnight before decanting.
- Flow control mechanisms vary widely and many may be constructed using simple materials. Two of the most common are shown here. The disinfection method of relying on manual dosing of storage tanks is not recommended as it is prone to human error and results in erratic chlorine levels.
- Application of hypochlorite solutions should be at a point of turbulence to ensure adequate mixing. The best site is immediately prior to a storage tank or reservoir as this allows the required contact time of one hour before water enters the distribution network. Chlorine for disinfection is added after all other treatment processes have taken place.
- It is important that there is regular monitoring of chlorine levels after dosing and also in the distribution network. The application of chlorine should be adjusted based on the data obtained from this monitoring.
- Chlorine is a dangerous substance. It should be handled with care. All installations where chlorine is used and stored should be secure, especially against children. Site security should be periodically checked.

1 Drip feed chlorinator

Used for small community water supplies, they feed a constant rate of drops of hypochlorite solution into the flow of water. The flow of water is assumed to be constant therefore the chlorine dose is constant.

The flow of chlorine solution is controlled in this system by the depth of the regulating tube in relation to the surface level of the hypochlorite solution. With the floating bowl this remains constant regardless of the depth of hypochlorite solution in the tank.

The delivery tube is open at both ends and should allow unrestricted flow. This system can be adjusted to supply only a few litres per day of hypochlorite solution.

Adjustment is by raising the regulating tube (decreasing flow) or lowering the regulating tube (increasing flow).

2 Constant head aspirator.

A simple device which with elementary care can prove reliable for many years.

The air inlet to the aspirator is through the glass tube. As chlorine solution is released from the aspirator air is drawn down the glass tube and released into the aspirator. Atmospheric pressure is therefore at the foot of the glass tube and the flow out of the bottle is independent of the amount inside.

The flow from the aspirator is adjusted by rotating the capillary between horizontal and vertical positions as shown. Coarse adjustment is made by altering the height of the glass tube.

The capillary bore most suitable for maintaining a trouble free drip is 0.7 - 1.0mm and the centre glass tube should have a diameter of 10 - 15mm.

This system can deliver as little as 1 - 2 litres per day.

Chlorine solution is allowed to flow freely to the dosing point.

The solution should be topped up to the foot of the neck of the aspirator and the bung pressed carefully into position. Air should not leak around the bung and the foot of the centre glass tube may need to be repositioned. After recharging, the capillary should be set to the vertical position and left to drip until the glass tube is full of air and begins to bubble into the aspirator. The flow rate can then be set by rotating the capillary into position.

The operator should understand the principle of the dosers so that the necessary care and adjustments are made when recharging.

Reference: WHO, 1992. Facts Sheets on Environmental Sanitation for Cholera Control. WHO/CWS/92.17

Prepared in collaboration with the Institute of Water and Sanitation Development, Zimbabwe.



TESTING FOR CHLORINE

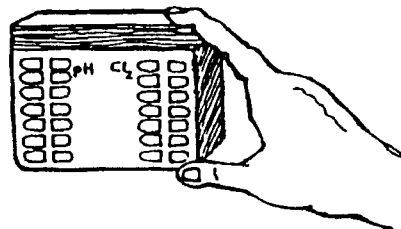
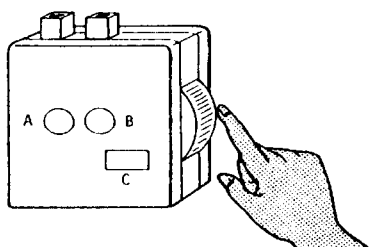

Two common colour comparators used for measuring chlorine

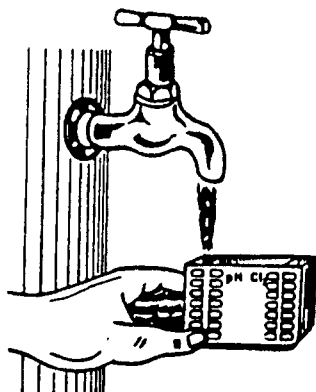

1 Rinse the comparator three times with the water which is to be tested and fill the cells with the water

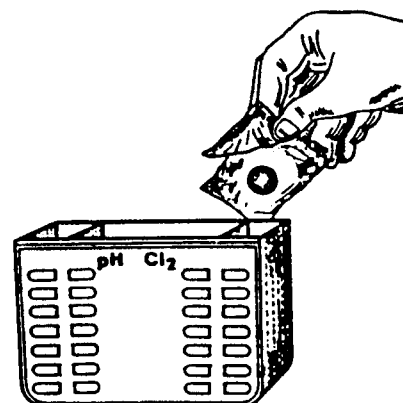

2 Add one DPD tablet to the water in the test cell

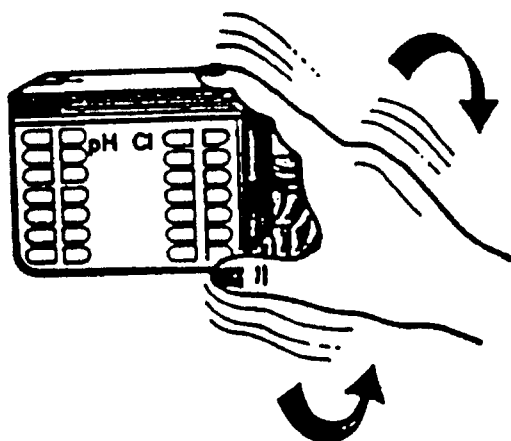

3 Shake until the tablet is dissolved. Compare the colour with the colour scale and read the amount of chlorine in the water

NOTES

Why test for chlorine?

Chlorine is added to drinking water to kill germs which cause disease such as cholera and typhoid. If there is too little chlorine in the water, germs may not be killed and there is a risk of disease outbreaks. If there is too much chlorine in the water it will not taste good and people may prefer the taste of less safe water supplies.

Chlorine disinfection

Chlorine disinfection is usually done to leave a residual level of chlorine in the water which prevents contamination in the distribution system. When chlorine cannot be found in a distribution system this may indicate that contamination has entered the system.

On-site testing

The most important kind of chlorine to measure is "Free chlorine". Free chlorine disappears quickly once a water sample has been taken and therefore water testing for free chlorine should be done on-site.

Testing methods

DPD (N,N-diethyl-paraphenylene-diamine) is the recommended chemical for measuring free chlorine in water. It is advisable to maintain good stocks of DPD which is supplied as tablets in foil strips, and the use of tablets allows simple and easy testing in the field.

There are many types of equipment used for chlorine testing using the DPD reagent. The simplest and cheapest are colour comparators as shown.

Measurement of pH

It is important to measure pH at the same time as chlorine since chlorine only works well at pH values of less than 8.0. Some chlorine comparators allow pH to be measured at the same time as chlorine using a tablet reagent called phenol red.

Acceptable chlorine levels

Chlorine residual can be tasted at levels of 0.8mg/l and thus such high levels should be avoided at the point of consumption. In piped systems 1mg/l of free chlorine should be present when water leaves a treatment plant and enters the distribution system.

Within the distribution system 0.2 - 0.5 mg/l of free chlorine should be present at all points.

Where there is a risk of cholera or a diarrhoeal disease outbreak has occurred chlorine residuals of:

1.0mg/l for standposts and wells; and

1.5mg/l at the point of filling tanker trucks,

should be maintained.

References

WHO, 1992. Facts sheets on environmental sanitation for cholera control, WHO/CWS/92.17

WHO, 1985. Guidelines for Drinking Water Quality, Vol 3. Drinking water quality control in small community supplies, 121pp.



CLEANING AND DISINFECTION OF STORAGE TANKS, TANKER TRUCKS AND PIPELINES

WHEN TO DISINFECT

<u>Storage tanks</u> After construction or repair; Pollution believed to have occurred	<u>Tanker Trucks</u> On commissioning; Water source of suspect quality.	<u>Pipelines</u> On commissioning of new or repaired pipelines.
--	---	--

1 *Disinfecting Storage Tanks*

Scrub the walls of the tank with 0.2% chlorine solution. Rinse out with clean water.

Fill with water from the water source.

Whilst filling add 1l of 0.2% chlorine solution per cubic metre of water.

Leave the tank for 24h and check the chlorine level is below 1mg/l (1ppm) before releasing to the distribution system.

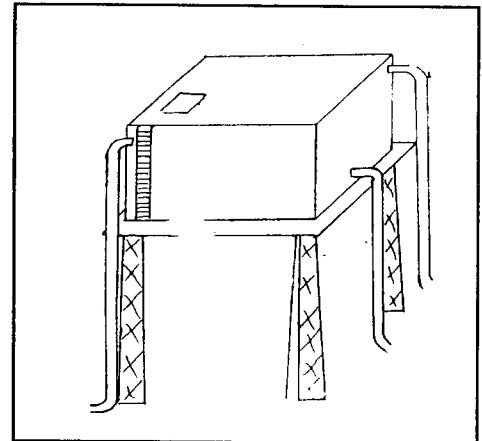

2 *Disinfecting Tanker Trucks*

Spray rinse the tanker before use with 0.2% chlorine solution using a pump, then leave closed overnight.

Rinse out with clean water. If the water source is chlorinated then the tanker can be filled ready for delivery.

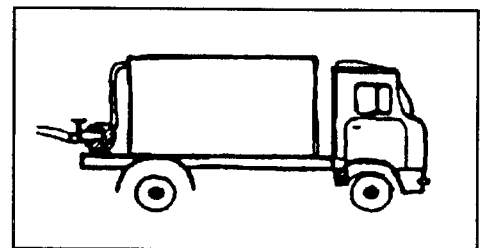

3 *Disinfecting Pipelines*

Fill the pipeline with a 0.2% chlorine solution and leave overnight.
Drain the disinfectant and flush with clean water.

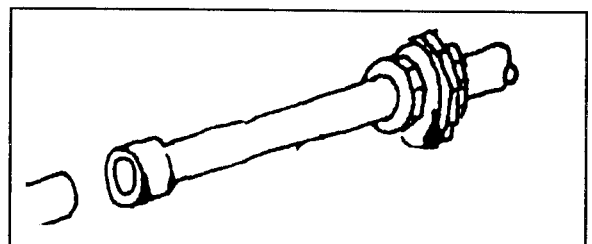

NOTES

MAKING THE DISINFECTANT

Product (% by weight available chlorine)	Amount for 0.2% solution
Calcium hypochlorite (70%) or Bleaching powder or chlorinated lime (30%) or Sodium hypochlorite (5%) or Sodium hypochlorite (10%)	60 grams in 20l water 132 grams in 20l water 1l in 20l water 440ml in 20l water

- Disinfection is carried out to kill germs which cause diseases such as cholera, typhoid and many diarrhoeal diseases.
- Sanitary surveys should be carried out to identify and rectify any problems before testing for bacteria.

1 Storage tanks

- Ensure that the storage tank is properly protected to prevent animals and plants from falling in otherwise any disinfection will have very limited benefit.
- If there are suspicions about the quality of the water then a bacteriological test should be performed on water in the tank as well as water entering the tank from the source.
- If after disinfection the chlorine level of the water is above 1mg/l (and therefore unpalatable) the tank should be drained and flushed with clean water.
- Storage tanks carrying unchlorinated water should be tested for contamination with bacteria every 6 months. If contamination remains high after disinfection check the water source and carry out a sanitary survey of the tank. It may be necessary to continuously chlorinate the tank by adding a small amount of chlorine every day.

2 Tanker trucks

- Tanker trucks are often used in urban or peri-urban areas or during emergencies.
- Tanker trucks can easily become heavily contaminated depending upon the filling procedures, the source of water and the condition of the tanker.
- Where chlorinated water is being delivered the level of residual chlorine in each load should be tested.
- If the water source is not chlorinated then enough chlorine should be added to give a chlorine residual of 1mg/l (1ppm). The level of free chlorine can be measured using a chlorine tester

3 Pipelines

- Due to the risk of contamination a surface water supply should always be treated before entering a piped distribution system.
- When laying new pipes each pipe should be cleaned with water before laying. Contamination of pipes with dirt can be reduced by proper storage and handling. The ends of pipes should be covered or blocked while work is not being carried out in order to prevent animals or dirty water getting in.
- When disinfecting a pipeline a closed control valve is necessary to stop the disinfectant from draining out of the far end.
- In chlorinated piped supplies a residual chlorine test within normal limits (0.2 - 0.5mg/l) suggests no need for bacteriological testing beyond the normal recommended frequency (see fact sheet on microbiological examination).
- Tanker trucks should be tested for bacteriological contamination every month.

Reference:

WHO, 1992. Facts Sheets on Environmental Sanitation for Cholera Control. WHO/CWS/92.17

Prepared in collaboration with the Institute of Water and Sanitation Development, Zimbabwe.



SANITARY SURVEILLANCE OF WELLS AND BOREHOLES

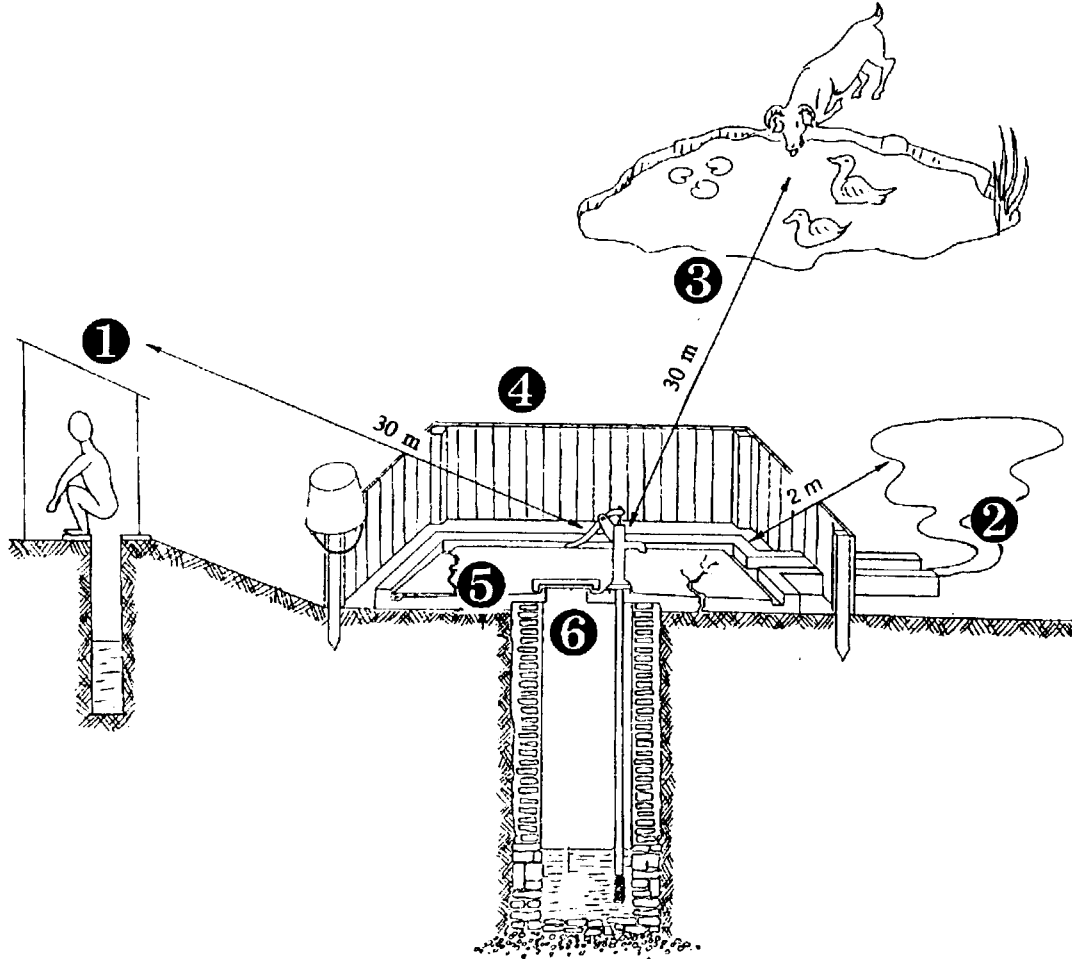

Community water point with handpump

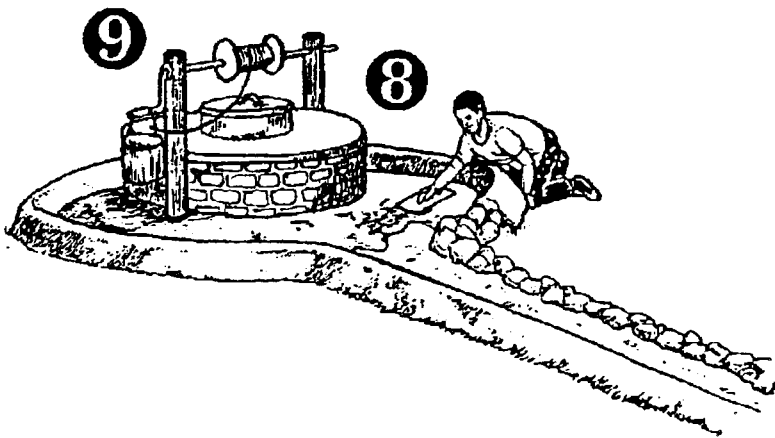

Protected shallow well

		RISK	
		YES	NO
1			
2			
3			
4			
5			
6			
7			
8			
9			

NOTES

A sanitary inspection is an on site inspection of a water supply and its surroundings to identify actual and potential sources of contamination. The physical structure and operation of the system and external environmental factors such as latrine location are examined to assess the risk that a water supply is contaminated. Regular sanitary inspections, together with remedial action where necessary, is an important activity in diarrhoeal disease control.

When reviewing the following sanitary inspection points a yes answer to the questions means that there is a risk of contamination and remedial action should be taken. The results can be recorded on the table shown on the front.

- 1 Is there a latrine within 30m? A latrine close to the well or borehole could contaminate the groundwater. This distance should be increased if the planned location for a latrine is on higher ground than the water point.
- 2 Is waste water accumulating near to the well or borehole? Provision should be made for drainage from the water point. Make sure that this is effectively carrying waste water away from the well or borehole. Construction of a small garden or soakaway reduces problems of waste water.
- 3 Is there a pond, rubbish heap, cattle pen or other possible source of pollution within 30m? To reduce problems of contamination they should be sited more than 30m from the water point.
- 4 Can animals gain access to the water point? Fencing around the borehole should be adequate to prevent animals gaining access with resulting damage to the water point and risk of pollution.
- 5 Is there ponding of water on the apron or is it cracked? The top of the well or borehole should be protected with a concrete apron to prevent erosion, accumulation of water and entry of polluted water into the well or borehole.
- 6 Is the pump loose or damaged where attached to the well? The pump, whether a handpump or a motorised pump, must be securely fixed to prevent water entering the well or borehole from the surface.
- 7 Is the bucket for collecting water left on the ground or otherwise subject to contamination? Containers used for collecting water from the water point should not be left lying on the ground and should be cleaned before use.
- 8 If a well, is it protected by a raised collar? Open wells should be protected by the construction of a raised collar and a cover. These should be inspected for cracks which could allow contamination from the surface. All the above points also apply to open wells.
- 9 Is the bucket for collecting water left on the ground or otherwise subject to contamination? Well water can be collected relatively safely with a bucket and windlass if a pump is not available. The bucket should be stored off the ground.

References

WHO, 1992. Facts Sheets on Environmental Sanitation for Cholera Control. WHO/CWS/92.17

Lloyd, B, & R Helmer, 1991. Surveillance of Drinking Water Quality in Rural Areas. Longman, 171pp.

Morgan, P.R. 1990. Rural Water Supplies and Sanitation. Macmillan, 358pp.

NOTES

A sanitary inspection is an on site inspection of a water supply and its surroundings to identify actual and potential sources of contamination. The physical structure and operation of the system and external environmental factors such as latrine location are examined to assess the risk that a water supply is contaminated. Regular sanitary inspections, together with remedial action where necessary, is an important activity in diarrhoeal disease control.

When reviewing the following sanitary inspection points a yes answer to the questions means that there is a risk of contamination and remedial action should be taken.

1 Are there leaks at any points in the piped system? Leaking pipes not only cause a wastage of water but also can allow contamination to enter the pipes during periods of low water pressure.

2 If there is a break pressure tank (or tanks) is there any risk of contamination entering the tank through the cover or cracks? The break pressure tanks should be covered with a sanitary cover which has a raised lip to prevent water entering from outside.

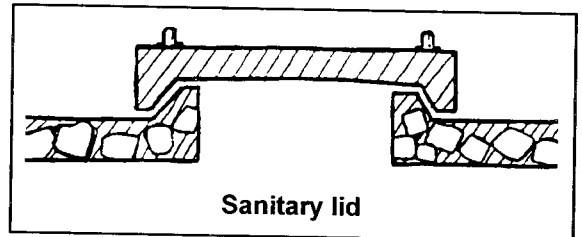

3 Are there any serious cracks in the storage tanks? Cracks on the side may allow water to leak and be wasted but deep cracks on the top of the tank can allow contamination to enter with rainwater.

4 Is there any risk of contamination entering the storage tank through the cover or air vent? The storage tank should be covered with a sanitary cover which has a raised lip to prevent water entering from outside. Any air vent should be covered with wire mesh to prevent animals entering.

5 Is there a risk of the water being contaminated through the overflow pipe? Wire mesh placed over the end of the overflow prevents animals from entering the storage tank and contaminating the water.

6 Does the tap leak? Excess water around the tap stand can result in unhygienic conditions from animal droppings, fly and mosquito breeding, and mud.

7 Is the apron excessively cracked? Cracking can allow water to accumulate making the water point unpleasant to use, attracting animals and encouraging fly breeding.

8 Does water accumulate at the end of the drain? Provision should be made for drainage from the water point. Construction of a small garden or soakaway reduces problems of wastewater.

9 Is there excreta or rubbish accumulating around the water collection point? Good environmental hygiene helps to protect water from contamination during collection or during transport home.

Problems observed in the sanitary inspection should be corrected as soon as possible.

References

WHO, 1992. Facts Sheets on Environmental Sanitation for Cholera Control. WHO/CWS/92.17



COLLECTION OF WATER SAMPLES - SAMPLING

Frequency of sampling and analysis of small community water supplies.

Type of supply	Bacteriological testing	Physical /chemical
Community open wells	nil - contamination expected	once
Protected dug wells or tube wells with handpumps	Once	Once
Protected springs and piped supplies	twice yearly	twice yearly
Rainwater collection systems	nil	nil

Sampling frequency for large piped water supplies.

Population served	Frequency of sampling
< 5000	1 sample monthly
5000 - 100 000	1 sample per 5000 popn. monthly
> 100 000	20 samples monthly plus 1 sample per 10 000 popn. monthly.

Priority tests

<p>1 <u>Sanitary survey.</u> Where this is unsatisfactory contamination may be assumed and appropriate precautions and remedial action taken.</p>	<p>2 <u>Faecal coliforms.</u> Indicators of contamination of water by human or animal excreta. (Total coliforms are not considered to be useful indicators in unchlorinated supplies).</p>	<p>3 <u>Turbidity.</u> The amount of "cloudiness" in water. Too much turbidity prevents disinfectants from working properly.</p>	<p>4 <u>Chlorine residual.</u> The amount of chlorine in the water. Where water is disinfected with chlorine there should be residual chlorine in water throughout the distribution system to protect against contamination.</p>	<p>5 <u>pH.</u> A measure of the acidity of the water. This can affect the ability of disinfectants to kill germs.</p>
--	---	---	---	---

NOTES

Selecting sampling points

- sampling points should be selected such that the samples taken are representative of the different sources;
- sample points should include those that yield samples representative of the most unfavourable parts of the water supply system from the point of view of possible contamination (such as loops, reservoirs, low pressure points in piped systems);
- there should be a sampling point directly after the clean water outlet from each treatment plant;
- sampling points should be chosen that are generally representative of the piped system as a whole and its main components;
- sampling should take into account the number of inhabitants supplied by each source.

Sampling for microbiological testing

One of the key elements in quality control of drinking water is the microbiological examination of the water. In collecting water samples for this purpose the following requirements should be satisfied:

- sampling should be properly planned and carried out at a frequency to detect any seasonal changes in water quality;
- samples should be collected, stored and dispatched in suitable sterilised bottles;
- the volume of water collected should be large enough to permit an accurate analysis;
- the sampling points in the water supply system should be selected such that the samples are representative;
- contamination of the sample should be avoided;
- analysis should be carried out as soon as possible and precautions taken to ensure the handling of the water sample does not invalidate the test;
- the sample should be properly labelled to avoid errors.

Small water supplies

For small rural water supplies from point sources sanitary surveys are the most important activity to be carried out on a regular basis and should be satisfactory before proceeding with microbiological investigations.

Disease outbreaks

During outbreaks of cholera or other diarrhoeal disease, sampling and analysis should be done more frequently than for routine analysis. All water supplies may need to be examined for safety by sanitary inspections, microbiological, physical and chemical tests with remedial or preventive action taken where necessary.

Reference:

WHO, 1992. Facts Sheets on Environmental Sanitation for Cholera Control. WHO/CWS/92.17

WHO, 1985. Guidelines for Drinking Water Quality, Vol .3. Drinking water quality control in small community supplies.



COLLECTING WATER SAMPLES - METHODS

Sampling from a tap or pump outlet

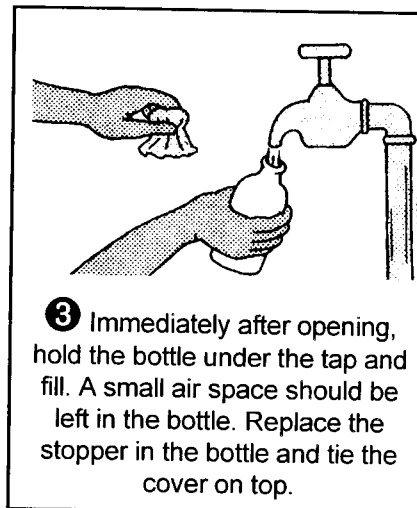
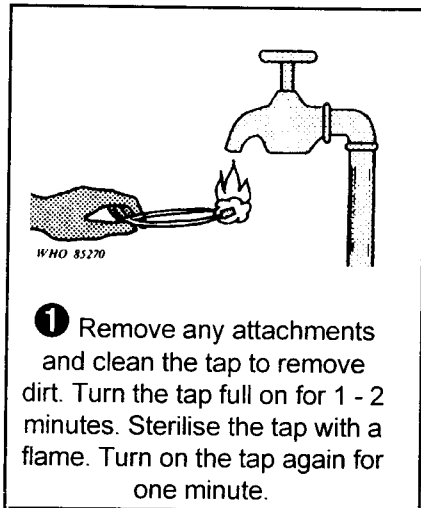

Sampling from a water course or reservoir

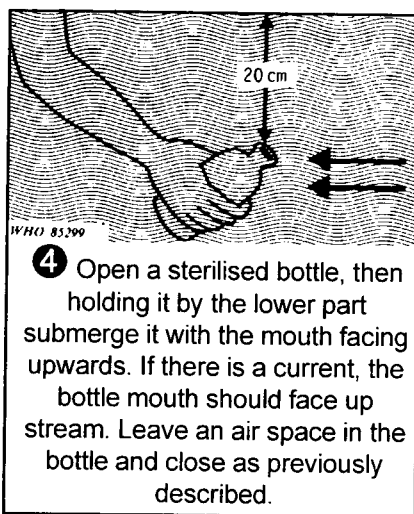

Sampling from dug wells

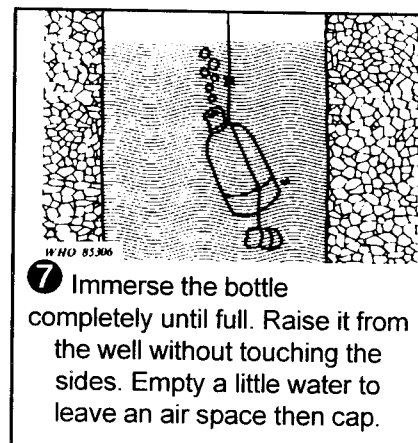
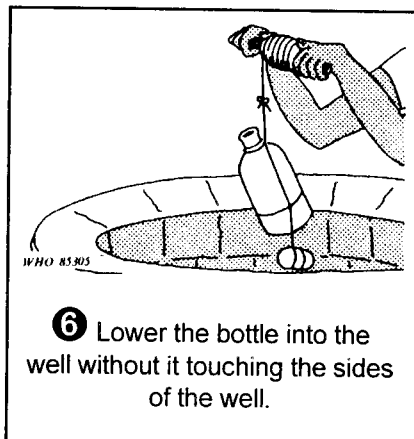
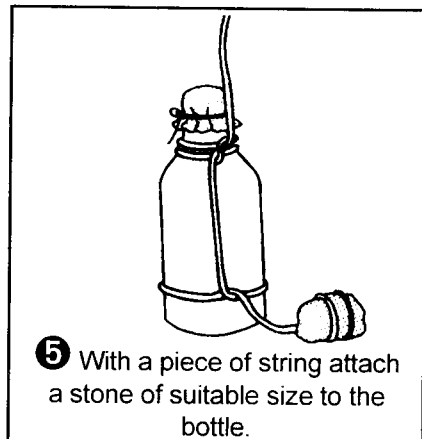

NOTES

- Bacteriological analysis results are used to check whether the water supply is contaminated and whether there is any risk to the consumer.
- Collecting water for microbiological sampling requires special care to avoid contaminating the sample. If care is not taken, a water source may be condemned without cause and much time and resources wasted examining specimens.
- Sampling of water from a chlorinated system follows the same procedure as described here with the exception that 0.25ml of a 1.8% sodium thiosulphate solution is added per 250ml of bottle capacity prior to sterilisation. The sodium thiosulphate neutralises any residual chlorine that may be present.
- Sample bottles are sterilised by heating in an autoclave (or pressure cooker) for 20 minutes or by heating in a dry oven at 170deg C for one hour.

Sampling from a tap or pump outlet

- 1 To ensure that the water sampled is not contaminated by the tap, the tap is first cleaned and sterilised. The water is run for a short while to ensure that fresh water from the distribution system is collected for testing.
- 2 Care must be taken when handling sterilised bottles to avoid contamination. The top should only be removed immediately before collecting the sample and the top of the bottle should not come in contact with the hands or other surfaces.
- 3 The bottle is filled close to the top but leaving enough air space for the water to be mixed in the laboratory. The stopper should be held without touching the inside and replaced on the bottle immediately after collection of the sample.

Sampling from a watercourse or reservoir.

- 4 The bottle is held away from the body and facing upstream. Gloves should be worn if there is a suspected health risk from the water. As with sampling from taps the sterility of the stopper should be maintained and replaced on the bottle immediately after the sample is collected.

Sampling from dug wells

- 5 A stone is attached to the bottle so that it will sink and fill properly. The bottle is not opened until the last moment before lowering into the well.
- 6 A length of clean string is used to lower the bottle into the well. The sides of the well should be avoided so that dirt does not fall into the bottle.
- 7 The bottle is allowed to fill completely and then raised to the surface. Some water is poured out to leave a small air space before replacing the stopper.

References

- WHO, 1992. Facts Sheets on Environmental Sanitation for Cholera Control. WHO/CWS/92.17
- WHO, 1985. Guidelines for drinking-water quality. Vol. 3. Drinking-water quality control in small community supplies. World Health Organisation, 121pp.