



in 8590, free

September 1990

EM/ES/416-E  
Distr: RESTRICTED

Assignment Report

**A STUDY ON THE LOCAL MANUFACTURE OF  
PLASTIC LATRINE PANS IN EGYPT**

Dr Hassan Mitwally  
WHO Consultant

The contents of this restricted document may not be divulged to persons other than those to whom it has been originally addressed. It may not be further distributed nor reproduced in any manner and should not be referenced in bibliographical matter or cited.

Regional Office for the Eastern Mediterranean  
World Health Organization  
P.O. Box 33190, 2009 AD, The Hague  
Tel: (070) 874211 ext. 141/142  
Date: 8590  
No: R 323.1 90ST



WORLD HEALTH ORGANIZATION  
REGIONAL OFFICE FOR THE EASTERN MEDITERRANEAN  
1990

## TABLE OF CONTENTS

	<u>Page</u>
<b>SUMMARY</b>	
1. TERMS OF REFERENCE	1
2. REVIEW OF LITERATURE	1
2.1 A survey of Alternative Waste Disposal System	1
2.2 Appropriate Technology for Water Supply and Sanitation	2
2.3 Four Decades of Latrine Development	2
2.4 Sanitation for Rural India	2
2.5 Health and Development, A Case of Ayadaw Township, Burma	2
2.6 Evaluation Study of the Burma Latrine Programme	3
3. PROCEDURES ADOPTED	3
4. OBSERVATIONS AND COMMENTS	6
4.1 General Background	6
4.2 Market Survey	7
5. CONCLUSIONS AND RECOMMENDATIONS	8
Brochure, in English	13
6. SUMMARY IN ARABIC	
Brochure in Arabic	

### Tables

1. Known Local Plastic Manufacturers
2. Companies Capable of Manufacturing Imported Sample Plastic Latrine Pan

### Figures

1. Isometric View of the Imported Sample Plastic Latrine
2. Imported Plastic Latrine Sample
3. Imported Plastic Latrine Sample with Modified Outlet of 4 Inches
4. Mould Used for Casting Concrete Slabs in the 50's
5. Square Plan: Concrete Latrine Slab

6. Square Plan: Concrete Latrine Sides
7. Circular Plan: Concrete Latrine Slab
8. Isometric View of the Locally Manufactured Plastic Latrine Pan
9. Locally Manufactured Plastic Latrine Pan
10. Isometric View of the Imported Plastic Latrine Pan Directly Above Its Pit
11. Proposed Position Beside the Pit for the Imported Plastic Latrine Pan
12. Proposed Position Far From the Pit For the Imported Plastic Latrine Pan
13. Proposed Position Above the Pit for the Locally Manufactured Plastic Latrine Pan
14. Proposed Position Beside the Pit for the Locally Manufactured Plastic Latrine Pan
15. Proposed Position Far From the Pit for the Locally Manufactured Plastic Latrine Pan

#### Annexes

1. Copy of the Circular Letter Sent to Plastic Companies
2. Reply from the Egyptian Plastic and Electricity Works
3. Reply from the Medical Packing Company
4. Reply from the Alexandria Plastic Industries Company
5. Reply from the Universal Company for Plastic Industries
6. Reply from the Middle East Plastic Company
7. Reply from the Saad Hanna Sons Co.
8. Reply from the Al Sherif Plastic Factories
9. Reply from the Egyptian Company for Metallic & Eng. Ind.
10. Reply from the National Plastic Company
11. Personnel Met and/or Contacted

## SUMMARY

Egypt is one of the largest countries in the Middle East as its population reached 55 millions in 1986. About 30% of its rural population are deprived of latrine services in their houses which are mostly built of mud brick. This means that more than eight million rural citizens forming about 1.5 million families living in 1.5 million houses are in need of latrines. Additionally, the custom of defaecating in open areas and adjacent water courses is a bad habit that any person should not practise, especially a girl or a woman who should maintain privacy at the same time practise good hygienic habits. To overcome these hygienic and social problems, each rural house should have a latrine to be used by its residents. The first programme to introduce latrines to needy rural residents who lacked latrine services, was in 1932. Unfortunately this project did not prove to be a success due to lack of social and health awareness among farmers. The experiment was repeated during the 40's and 50's when it achieved considerable success. The latrines that have been introduced were the cheapest in the market at that time and were made of precast reinforced concrete, heavy in weight, yet relatively fragile. They needed to be handled with care, as they were to be installed with some difficulty, and cleaning was rather tedious. These latrines were of flat slab without bowl and water seal trap to prevent fermentation odour from reaching the latrine. Moreover, its price was far beyond the reach of the financial ability of the indigent rural residents. Fortunately, a plastic latrine pan appeared in the WHO South-East Asia Region and proved to be significantly successful when used in places similar to areas in Egypt. It was made of high density polyethylene, of white colour, light in weight, fine to touch and inexpensive. It was easy to transport, install and clean.

Local manufacturing of a similar plastic latrine was investigated and a market survey was carried out among manufacturers. The survey revealed that manufacturing a similar type of latrine pan is quite feasible and at a relatively low cost that would not exceed half the price of the known concrete slab. It could be used either directly above the pit if loaded on a special slab, or preferably adjacent to the pit on the ground in order to save the cost of the slab.

The plastic latrine pans with slightly different design are also produced by one of the plastic companies in Alexandria. It has all the advantages of the imported one in addition to being of the traditional oriental shape to which the citizens are accustomed. It is made of polypropylene, an ordinary plastic of an inferior quality than the high density polyethylene; however, it proved to be durable when used, and also it could be manufactured of HDPE at almost the same cost. It has been introduced to the local market a few years ago.

In general, the plastic latrine pan, whether similar to the imported sample or the one produced locally, has proved to have the required advantages of durability and can withstand any heavy weight as well as being light since its weight is about two kilograms complete with its water seal traps (when compared to the 135 kilograms being the weight of the precast concrete slab latrine). It is easy to transport, easy to install and can be

cleaned easily without water flushing. Its water seal elbows provide protection from odours emanating from the pit; it has a good looking shape and can be installed and taken off to be reused again, more than once, without any breakage or deformation. It is inexpensive and the cost is half of the price of other latrine pans.

Accordingly, it is recommended to introduce the locally-produced plastic latrine pans for use in rural areas. Also, it can serve efficiently in rural public buildings such as mosques, schools, public lavatories, government offices, recreational areas and similar places that require durable light latrines, easily transported, installed, and cleaned, especially where water is scarce. Moreover, it is an inexpensive latrine pan that can be afforded by all. Further, the use of a new plastic latrine pan will encourage its users to adopt hygienic habits. The plastic pan has the following advantages.

- (1) It is durable and can withstand any human weight.
- (2) It is light since its total weight is less than 2 kg as compared to the weight of the concrete slab latrine which is 135 kgs.
- (3) It can be transported easily.
- (4) It can be installed easily, whether directly above the pit or adjacent to it.
- (5) It can be installed, taken off, and reinstalled more than once without any breakage or deformation.
- (6) It is cleaned easily with little water where there is no flushing system.
- (7) It is cheap compared to other models since its price does not exceed LE 10.00, while that of the concrete slab is at least twice as much.

## 1. TERMS OF REFERENCE

The study on the local manufacture in Egypt of plastic latrine pans was carried out under a contractual services agreement and the terms of reference of the agreement were to:

- (a) review the existing relevant documents, reports and literature for possible production and use of plastic latrine pans in Egypt;
- (b) conduct a market survey in Cairo and Alexandria of possible production of plastic pans in Egypt and also discuss with sector-related government agencies to find out their views and reaction about the introduction of this technology in rural Egypt;
- (c) evaluate technical feasibility, cost effectiveness and develop a model drawing for a latrine, using plastic pans;
- (d) prepare a complete report and an executive summary with an overview of the literature, evaluation, cost comparison, technical specifications, model of latrine, findings and recommendations;
- (e) develop a sample promotional brochure, 1-2 pages in English with Arabic translation, indicating evaluation results, cost comparison, technical aspects, advantages, etc. for wide distribution to all sector-related agencies in Egypt.

## 2. REVIEW OF LITERATURE

The study commenced at the beginning of October 1989. According to the terms of reference, the review of the relevant documents was the first item to be handled. The subject of low-cost sanitation in rural areas was tackled from various points of views.

### 2.1 A survey of Alternative Waste Disposal System

The report of the survey was forwarded by Norbert Schornaner, Director of the School of Architecture, McGill University (July 1973). After surveying different systems, the study came to the following conclusions.

- (a) The main objective of this study had been to look at alternative waste disposal systems which will conserve resources. The conventional flush system is well known and has many advantages, but its general application is not feasible due to the large initial investment in order to supply and distribute water and to dispose of and treat sewage.
- (b) Probably, the most beneficial system for dealing with human waste is decomposition, where the waste is transformed into a useful product to be used in agriculture. It is a recycling of chemical elements not used by the body.
- (c) There is no simple system that offers a solution in every situation. What is required is a combination of various approaches.

(d) The greatest need is to reduce costs so that the system could be used by the greatest number of people. Until today the only truly low-cost system for low density settlements is the pit-latrine.

## 2.2 Appropriate Technology for Water Supply and Sanitation

In a publication by the World Bank, brought out in December 1980, entitled "Appropriate Technology for Water Supply and Sanitation", pour-flush (PF) toilets were recommended. They are used in India, Pakistan (South-East Asia) and some parts of Latin America. Two basic types of latrines are known. First, the simplest type is a modification of the pit latrine with water seal bowl. It can be of the direct discharge or of the offset pit design. In the second, "PF", type, the bowl is connected by a short length of pipe to an outside pit or a septic tank system.

## 2.3 Four Decades of Latrine Development

This publication was brought out by the Thailand Department of Health in cooperation with the United Nations Children's Fund. In order to have health for all by the year 2000, the Government planned to have latrine coverage by that time. The latrine type selected started with pit privy and ended with the water seal latrine which are both well accepted in Thailand. The four-step programme started in 1942, was to achieve 50% coverage by 1986, and planned 75% coverage by 1990, and 100% coverage by the year 2000.

## 2.4 Sanitation for Rural India

This brochure was issued during 1986 by the National Environmental Engineering Research Institute "NEERI" at Nagpur, India, and showed that NEERI, since its inception, has been engaged in rural sanitation programmes and development of appropriate technology. In collaboration with other relevant agencies, it has constructed over 1200 latrines of its design and assessed the beneficial effects of those on the health status of the user communities. The sanitary latrine programme, as evolved by NEERI, provides training to rural artisans in the art of casting of cement concrete water closet pans and traps and the construction of the pour pit latrines. It also supplies the Public Health Engineering and other relevant Departments with needed material and information.

## 2.5 Health and Development, A Case of Ayadaw Township, Burma

In this publication, dated April 1986, issued at Rangoon, Burma, a community participation latrine programme was illustrated. The programme, started from less than 0.01 per household coverage during 1973-74, and was envisaged that by the beginning of 1986, each household would have access to one sanitary latrine. The programme was successful and the reasons for acceptance of this latrine programme were appropriate technology, easy accessibility, and acceptability since the following points were covered:

- (a) involving the community right from the planning stage.
- (b) decentralization of decision making in selection of type and site of latrines
- (c) giving prestige by showing their success in implementation and sharing their experiences
- (d) willingness of the community to share their experiences
- (e) cohesiveness of the village community



- (f) proper leadership and supervision by higher level personnel
- (g) appropriateness of the design of the squatting plate and PVC pans to cover the following requirements:

- No smell
- Fly proof
- Comfortable
- Accessible and secured
- Less risk of poisonous snake bite (since there are instances of snakebites of those defecating in the bush)
- Using little amount of water
- Low Cost if not affordable

### 2.6 Evaluation Study of the Burma Latrine Programme

In the latrine programme evaluation study carried out in some towns in Burma by the United Nations Children's Fund in December 1986, it was found that 71% of the latrines were functioning satisfactorily in the project areas, while 96% of the households were using the programme latrines provided in the project areas. It was felt that the community acceptance of the programme was sound and satisfactory and more community involvement was recommended.

### 3. PROCEDURES ADOPTED

In March 1988, a communication was sent by the WHO Regional Office for Eastern Mediterranean to the UNICEF East Asia and Pakistan, the Director of the Division of Environmental Health at WHO Headquarters, the NEERI Director, WHO Islamabad and to WHO Project Coordinator in Cairo, requesting information on their experience as to the production of pans, materials used, design and evaluation of flush latrines. The replies received indicate that many of the Asian countries, with UNICEF-assisted water and sanitation projects, promote and utilize the PF latrines, and, as a result, were engaged in the local production, and/or purchase, of pans which are made of a variety of material. Two countries which pursued this activity very extensively are Burma and Bangladesh: former uses plastic pans, while the latter produces mainly a type made of cement. This cement type can be either of water seal design to be used for single pit latrine in the UNICEF-assisted programmes or of water seal trap design to be used for offset twin pit latrine in the urban sanitation projects supported by the Netherlands and other funding agencies. Both designs use little water to flush. The WHO/UNDP Project Coordinator in Cairo informed that plastic pans are available in the market without defined specifications or source, and that no evaluation reports are available.

The plastic latrine was best explained in the response received from UNICEF, Burma: "Currently UNICEF is providing imported (plastic) pans, which are imported from Malaysia. These pans are white in colour, light (730 gms) and smooth in texture. The people's acceptance is very high as it is very easy to clean, light to transport and easy to install. Local production itself is not difficult if raw material (petrochemical product) is readily available. In Burma raw material is a problem, along with other management problems, therefore, there is no immediate plans for local manufacture.

"As the type of latrines vary with preference of the people in various locations of the country, which depend mainly on cleansing habits and water

availability, we are using four types of pans. The main body of pan is same in all cases, only the connection to the pit varies as follows:

Type I: This type of pan has a goose neck water seal: the pan is placed directly on the top of pit. This type needs only 1 to 2 litres of water to flush.

Type II: This type has a S-trap as water seal and pit is offset from the pan and connected by means of one meter long pipe. This type needs 3 to 5 litres of water for flushing.

Type III: This type has no water seal and the pan sits directly on the top of the pit. This type needs very little water to flush, but if not covered and cleaned adequately smell and fly breeding may be a problem.

Type IV: This type has no water seal and the pit is offset, pan is connected to pit by one meter long pipe. This type needs very little water but if pan is not covered and cleaned adequately, smell and fly breeding may be a problem.

"In all above noted types the plastic pans have been highly successful with no technical problem reported so far. It has been found, especially very appropriate, where long distance transportation through bad roads is involved.

"The selection of type depends on the cleansing habits of the community and their preference. In Burma people use sticks, papers, mud balls and water as cleansing material at various locations of the country.

The costs of a complete set of pan with extension pipe and water seal FOB Malaysia is about US\$400."

The National Environmental Engineering Research Institute (NEERI) at Nagpur, India, provided the following information about the production of latrine pans:

(1) Production of Pans. Experience indicates that cement pans can be conveniently cast by communities with the help of local masons. The mould for the trap and the pan can be centrally supplied. NEERI has experience with local self-government agencies, which have bought the moulds from NEERI, and obtained training at NEERI (for 5 days). These agencies have constructed low-cost latrines in their areas.

Plastic pans have to be manufactured by and supplied by the entrepreneurs. The cost of the mould for pan, trap and bend is \$ 15 for casting cement pans. A plastic pan with bend would cost \$8/-.

(2) Materials used. Either cement pans or plastic pans are recommended. The use of cement pans by a community is expected to generate employment to local artisans. Plastic pans are convenient to transport.

(3) Water required for flushing is about 3 litres for both cement and plastic pans.

(4) A collaborative project between NEERI and other agencies was taken up and completed within a span of 10 year . Household pour flush water-seal pit

latrines were constructed in 10 project villages. Other sanitary measures were also introduced in some of these villages and a programme of health education was launched. A health survey was undertaken before and after the introduction of sanitation facilities. It was observed that, with full involvement of the beneficiary community and an integrated approach, health improvement can be brought about in the community by providing sanitary facilities, and safe water supply, and health education.

In other latrine programmes in India, the users were very happy and satisfied with the installations for which they have partly paid themselves. The system worked better in urban areas. The cleaning of the pans was better than in rural areas.

The question whether it is possible or preferable to make the pan of plastic material was considered and based on the responses received previously, the following were decided upon:

(1) The material most commonly used for the production of pans is cement. It is relatively cheap and could be produced by the communities themselves. The surface of the pan could, however, be rough and it will be difficult to clean the pan properly.

Plastic material is used in India and Burma. The plastic pan is light, easy to transport and easy to clean. It also gives the pan a more attractive appearance. The cost, however, is higher. However attractive, light, durable, smooth surfaced (easy to clean) the pan is, it is more costly may be more expensive by few cents.

Ceramic pans are used, but the cost is higher and the pans have to be produced in a special factory.

(2) The design of pans is important, and should be given appropriate consideration. It should be tested and approved by the communities.

The market survey was delayed due to the late arrival of the samples plastic latrine pans. The preliminary findings of the survey are given in the following paragraphs.

EMRO was requested to import two samples of the main body of plastic latrine pans from Burma to be used as a prototype to enable the local manufacturers in Egypt to work out prices, etc. The specification for the plastic latrine was mentioned as high density polyethylene (HDPE). It was explained that the construction material adopted in Burma for this latrine was from material available locally. A cost comparison showed that the average cost of a completed latrine with a substantial building was US\$25.50 for VIP type latrine and US\$27 - 31.50 for a plastic latrine.

The market survey was delayed due to late arrival of the samples of plastic latrine pans. The preliminary findings of this survey are given in the following paragraphs.

Two plastic factories, El-Sharif Co. and the National Plastic Co., which were contacted in February 1989, were once again contacted on 20 July 1989 and were requested to submit their cost estimates for making pans similar to those imported from Malaysia.

El-Sherif Co. has already submitted their quotation, but the National Plastic Co. has not responded. The company asked for I.E 100 000 for making the mould alone, but has not given any price per unit of pan. The price will depend on the demand. But according to the information given by them, the unit price will not change to any great extent unless the yearly production exceeds 500 000 units.

The National Plastic Co. lack facilities to develop the mould and was reluctant to offer a quotation.

However, before any production of plastic pans starts in Egypt, it would be advisable to explore first the people's acceptance of the pan and its design and try to obtain a rough figure of the annual demand. During the period of about 6 months of the use of the pan, its design and performance as well as people's acceptance should be studied. After this period the findings should be evaluated to arrive at a basis for a decision as to how to proceed further.

After reviewing the existing relevant documents, reports, and literature for possible production, and use, of plastic latrine pans in Egypt, the plastic latrine sample was investigated as regards to its functional suitability and durability. This was in the light of previous experience of similar units in some of the Middle East countries. The outlet portion of the pan, in addition to the water seal section, is recommended to be 10 cm (4") instead of 7.5 cm (3"), while other parts of the units could be provisionally the same. A letter, written in Arabic and in English, was sent to each factory dealing with plastic production (Annex 1). A provisional market survey was conducted by telephone calls to all known plastic factories in both public and private sectors in Alexandria and Cairo. The names of the plastic factories were obtained from the Ministry of Industry as well as from the directory of relevant investment companies shown in Table 1. Based on the responses, screening was done to identify the reliable firms as to their capability of production and sincerity of response. The survey revealed that three companies in the public sector and five in the private sector gave positive response (Table 2). Each factory was provided with the sample of latrine pan which was retrieved after a few days to be handed over to another company.

#### 4. OBSERVATIONS AND COMMENTS

##### 4.1 General Background

Latrines were not known in most of the rural houses in Egypt till the beginning of this century. Houses of rich farmers were the only ones that had latrines. The percentage of houses without of latrines was not less than 75% from the results of a sanitary survey carried out in the 50's by the Sanitary Engineering Section (presently, the Environmental Health Section of the Ministry of Public Health). In 1932, a latrine programme was introduced for the first time in local rural areas by the Rockefeller Foundation. Unfortunately, the programme did not prove to be a success due to lack of awareness among farmers, and the absence of with health education campaigns. In 1948, the programme was repeated and it achieved considerable success due to improvements aimed at rectifying the above deficiencies. During 1950, a project under the American Point 4 Programme was established at Kaliob, near Cairo, to provide needy rural inhabitants with precast concrete latrine seats at nominal or even free of cost. Figure 4 shows the wooden mould for casting

the concrete slab used in that programme. When the experiment proved to be successful, it was tried officially during 60's by the Government through the Department of Environmental Health, Ministry of Public Health, at Shobrament, Giza Governorate. Since 1970's the situation has improved considerably, although some difficulties are faced with respect to coverage and use of concrete seats. This was mainly due to its heavy weight, high initial costs and relative difficulty in cleaning.

Figure 5, 6, and 7 show details of concrete latrines which have been used in some local projects. Till now there is a considerable proportion of rural houses without latrines due to some of the reasons mentioned above. To overcome such deficiencies and to enhance introducing latrine seats into needy rural houses it is imperative to look for a seat that can provide the required function at a low cost to be affordable, easily transported, installed with no difficulty and easily cleaned. To investigate the possibility of introducing such a type of latrine to be used in rural areas of Egypt, it has to be manufactured locally at a reasonable cost.

#### 4.2 Market Survey

A market survey was carried out both in Alexandria and Cairo to investigate the possibility of local manufacture of latrine pans, and their cost. This was done by contacting the known plastic manufacturers personally or through mail (a specimen of the circular letter is Annex 1). The names of local manufacturers were obtained from relevant authorities and are in Table table 1. Of the twenty-five companies were contacted out of which eight only gave positive answers, one stated its inability, while sixteen did not respond. Of the eight companies that responded, four are in Alexandria and four in Cairo. Three of these companies are in the public sector, while five are in the private sector.

The prices quoted ranged from LE 6.05 to 11.00 per seat, in addition to the cost of moulds which ranged from LE 50 000 to LE 150 000. Only one public sector company showed capability of providing the moulds, while the other two asked that these be provided by the client. Four out of the five private sector companies quoted prices for the moulds, while the fifth asked for the mould to be provided. All relevant data in this connection are shown in Table 2.

The market survey was spread over about seven weeks since a number of companies asked for the sample to be kept in their factories for few days to investigate the material and dimensions.

Some manufacturers offered to provide a latrine made of other plastic material, such as acrylonitrile beutadayn styrene (ABS) or polyvinyl chloride (PVC) at a relatively high cost.

It was found during the survey that the Alexandria Plastic Industries Co. manufactures plastic latrine pans at a very reasonable price. The pan is made of normal plastic material in the traditional local oriental shape (Figures 8 and 9) which could be more acceptable to users. About twenty thousand units are produced per year for the local market, in addition to few thousands for export to neighbouring countries. A sample of this pan was collected for a comparative study. The water seal trap connected to this latrine is produced in other factories, and it is available in the market at a lower price. It is of P shape which is preferable in this position than the

shape that is connected to the imported sample. The price of this latrine pan is LE 6.50, while the price of the water seal trap ranged from LE 1.50 to 2.00. The manufacturers stated that their plastic latrine pans are sold in local rural areas without any difficulty, and are used without water seal elbow, a common custom in most of the rural areas. It was also stated that the latrine pan was being produced since a few years with a gradual increase in production to meet the demand in the local market, while export started a few months back which is also increasing gradually.

Replies from seven manufacturers, and their translation, are given in Annexes 2-9, while the eighth one (the National Plastic Company in Cairo) stated that its previous answer to WHO, dated September 1989, could be considered as still valid; this letter with its translation, is in Annex 10.

## 5. CONCLUSIONS AND RECOMMENDATIONS

(1) A considerable number of rural houses still lack latrines. Residents of such houses defaecate in stables and barns adjacent to their shelters, or in clay pots during day time to be evacuated outside their houses at night. Farmers defaecate in fields during their daily work, or in drains or adjacent streams. Contaminated water and soil, caused mainly by lack of sanitary means of human waste disposal, are the causes for the spread of communicable diseases among farmers with concomitant health and economic implications.

(2) A sanitary latrine in its simplest shape is a pit covered with a latrine pan (seat); however, significant improvements could be made by using water seal trap in addition to lined pit sides and a pipe connection to a septic tank. To provide a farmer with a latrine seat, it should be inexpensive, easy to instal and clean and maintain. Unfortunately, when latrine projects for rural areas introduced concrete seats they did not achieve the expected objective which might be due to the heavy weight of the seats and their relatively high cost, in addition to being rather difficult to instal and clean. To overcome such difficulties it is imperative to look for a durable latrine seat at a reasonable cost and of light weight which could be easily installed, cleaned, and maintained. Such requirements are met in a plastic latrine seat if it could be locally produced.

(3) The capability of manufacturing a latrine seat similar to the sample provided by the WHO Regional Office of South-East Asia (SEARO) was investigated locally and found possible with no difficulty, except of providing the moulds to some factories. However, the moulds could be locally manufactured by at least three companies, while they can also be imported as mentioned by two others. Three other factories expressed their inability to manufacture or procure the mould and they requested they be provided with the mould.

(4) The prices are very reasonable as compared to the traditional concrete slabs. They range LE 6.05 to LE 11.00, with an approximate average of LE 8.50 for a complete plastic unit of the imported type with the water seal accessories. On the other hand, the average cost of a concrete unit is about LE 25.00.

(5) The material of the sample presented is high density polyethylene (HDPE), of white colour. Its weight is 750 g for the seat pan, in addition to 315 g for the water seal elbows. The dimensions are 50 cm by 28 cm. for the seat only, while the depth of the whole latrine pan is 26 cm. which is

considered relatively high in comparison to other known latrine seats. The outlet and water seal elbows are 7.5 cm in diameter which is considered small for an outlet used in this part of the world. It should be 10 cm (4") to avoid any possible clogging. Figures 2 and 3 show the details of the latrine with 7.5 cm and 10 cm outlets.

(6) Presently a plastic latrine seat is being manufactured locally. It is produced by the Alexandria Plastic Industries Co., which is a small private sector factory, using production equipment far from being modern. The price quoted was LE 6.50 for the seat pan, in addition to LE 1.5 - 2.00 for the water seal section, with the total price the same as the average bid prices for the imported sample. The model of this plastic latrine, shown in Figure 8, is more convenient for the local users and more easy to instal. The material is polypropylene, an ordinary plastic which might be of relatively inferior in quality compared to the high density polyethylene; however, no complaint came to the manufacturers with respect to its durability since its first production a few years ago. On the other hand, there is growing demand for the product in the market. It is produced in light colours, with a weight of about 1860 g for the pan and 350 grams for the water seal trap.

(7) The manufacturers stated that the price of a similar latrine pan when made of HDPE would be LE 8.50 per unit. This is in addition to LE 1.50 for an ordinary plastic water seal trap, so the total cost would be LE 10.00. In this case, the cost of the moulds will be saved since they are already available and used for manufacturing the currently produced plastic latrine pans. When the manufacturers were asked about the minimum number of units they could manufacture as a sample of this type, they stated that any number, even few hundreds, would be possible since the moulds are available and they have only to change the merial from polypropylene to high density polyethylene.

(8) Officials of the Ministry of Health and public health departments in different academic institutions, as well as some specialists from other countries of the Region, were contacted in order to ascertain their views on the use of the proposed plastic latrine pans. Also, the staff of the Federal Environmental Health Department in Cairo responsible for human waste disposal in rural areas were met for technical discussions. Members of local councils in rural areas, community leaders, religious leaders, administrative staff, masons, plumbers, and expected users were among others who were met to introduce the idea of using a plastic latrine for rural inhabitants. Different views and ideas were expressed, some favouring or some modifying or others rejecting, especially when financial aspects were discussed. Methods of installation and location of the pan with respect to its pit were illustrated.

(9) Everyone was in favour of using a plastic pan in rural areas instead of a concrete slab or other types of latrine pans, in view of its weight, cost, and ease of installation, cleanliness and maintenance. None objected to (and in fact many even encouraged) the introduction of such pans to needy rural inhabitations; it was even recommended to be used in public buildings in rural and developing areas and in places where whose cleanliness and maintenance are problems such as in mosques, markets and governmental buildings. It is recommended also to be used in seasonal recreational places, and public latrines in open areas and fields.

(10) Although the imported plastic latrine pan was more acceptable than the concrete slab, it still needs a sort of concrete slab to fit in, especially

when the pit is directly underneath the pan as shown in Figure 10 or preferably when it is located beside the pit as shown in Figures 11 and 12. In both cases, the pan should be elevated a few centimeters above the ground level to avoid possible filling by soil. This will add an additional LE 10.- (the cost of concrete supporting slab) to the cost of the latrine pan. In this connection, the existing locally manufactured plastic latrine pan is preferable since it can be installed directly without concrete slab above the pit, especially when it is bored with auger as shown in Figures 14 and 15. This is one advantage among others of the locally-produced plastic latrine. The most important advantage is its traditional oriental shape to which the rural people are accustomed. On the contrary, the shape of the imported plastic sample is not familiar in this part of world as is the oriental seat. To utilize the advantages of both plastic latrine pans, i.e. to have a plastic latrine pan made of white colour HDPE with the traditional shape, the matter was investigated and found locally feasible at a reasonable price which will not exceed LE 10.00 for a complete pan with water seal trap. However, when both seats were exposed to the people concerned, the locally produced one was preferred by a large majority. This is in spite of the fact that they still prefer the imported seat to the concrete slab seat.

Finally, the consultant recommends the following:

(1) A locally manufactured plastic latrine pan should be introduced to rural residents who are in need of latrine services. It should also be introduced in latrine programmes to replace all types of the present precast concrete slabs. This should be preceded by a nation-wide health education and awareness campaigns directed to residents of rural areas and isolated communities and promote its use in houses, mosques, public buildings, public water closets, seasonal recreational facilities, and wherever concrete slab latrines are supposed to be used.

(2) The latrine outlet shall not be less than 10 cm (4") to avoid any probable clogging.

(3) Water seal traps could be eliminated from latrines in some rural houses where piped water is not available in ample quantities to clean and push faecal matters down into the latrine pit. Problems of odours emanating from decomposed faecal matters can be controlled by covering the latrine pan opening and ventilating the pit whenever feasible.

(4) Introducing the unfamiliar shaped plastic latrine pans of the imported model should be managed with care, especially when users are not accustomed with its shape or model since they might refuse the idea of using latrines in general and specifically the plastic ones. Its shape should be modified to conform to their knowledge with respect to latrine shapes, and to fit their local customs and traditions. Fortunately, the locally produced plastic latrines satisfy these requirements.

(5) The plastic latrine pans recommended for use should be of the already locally produced model which proved to be successful. This is based on the exceedingly large local and regional market needs. However, when this latrine pan was compared to the imported sample, the former is favoured by the vast majority of specialists and users. The price of this local model which is about LE 8.00, could be expensive than that of the imported model since the cost of the moulds will be saved. It will not be more expensive than the imported model even when it is made of the HDPE material like the imported.



The cost of the locally produced plastic latrine pan when it is manufactured of the HDPE is LE 10.00 which is still much less expensive than the cost of imported one. If the imported model is manufactured locally its cost would be LE 8.50, in addition to LE 20 being the cost of the supporting slab. Also, the cost of the moulds will be saved when using the locally-produced latrine pans.

(6) A follow-up survey should be carried out in rural areas where the local plastic latrine pans have been used to ascertain the extent of their acceptance by the users. Based on the results of this survey, a decision with respect to launching a nation-wide programme for plastic latrine pans production should be considered.

(7) The country's total needs of latrine pans should be determined and it should be so planned that the demand is met within a certain number of years. Based on the last census of 1986 in Egypt, as an example, which estimated the population at 55 millions, of which 50% lived in rural areas; of these, 30% live without latrine services. This means that about 1.5 million units will be required. Such a large quantity should be produced within a period of not more than 20 years. In other words the annual production should not be less than 75 000 units. It is, therefore, recommended to start with a few thousand units as an experiment till it proved successful and then the production could be expanded.

It is worth mentioning here that the manufacturers of the already locally produced plastic latrine pans showed readiness to manufacture any small quantity of their model when made of the required HDPE to be used as an experiment. The price of this experimental batch per unit will not be more than the rate stated in their bid and during their discussion with the consultant. This will be in addition to the saving on the cost of moulds. The initial cost of the mould, when made locally, ranged from LE 50 000 to 150 000, with an average of LE 100 000. This will work out to about LE 1.00, in addition to the cost of the latrine pan if the imported model is to be manufactured.

(8) A programme to provide partially the plastic latrine pans to rural residents should be launched. It should start with those who can afford the total cost, including the cost of installation. The others should be subsidized gradually, based on their needs to the extent that indigent people should be totally exempt from the payment of the cost. This is on the condition that nobody is exempted from digging the latrine pit or installing the latrine pan (except in very rare cases for old people). This condition must be fulfilled to realize the interest of the beneficiary in using the latrine, and to let him feel that he paid for a part of the cost, so it belongs to him and not to the donor and since the latrine is his own he will use it.

(9) Should the entire families are poor, a case which most probably does not exist, the programme management should consider meeting their needs. The total cost to cover the whole country would be about LE 15 million which is much less than the cost of a medium-sized urban sewerage system serving a fraction of a million population. It is also much less than the annual budget for curative services for relevant communicable diseases resulting from lack of latrines.

(10) Installation of plastic latrine pans in temporary camps and recreational areas is highly recommended. In this case they could be used without the water seal trap and installed directly above the pits which will be filled after every few days during which decomposition odours will not be noticeable. The plastic pans can be used, taken off, stored, and reused again several times.

EM/ES/416-E

B R O C H U R E

### PLASTIC LATRINE PANS

The custom of defecating in open areas, barns, stables, and water courses, in addition to special clay pots to be evacuated at night, has been practised by many rural people who have no latrines at home. Such a bad habit should not be practised by anyone, especially females who should maintain the privacy, as stated in all sacred texts. To overcome the associated hygienic and social problems, rural house should have a latrine for use by the members of the household.

Latrines, when introduced to rural areas in sanitation programmes, have been made of precast reinforced concrete. A concrete latrine has a weight of 135 kgs which is considered heavy for one or even two persons to carry. It is relatively fragile, needs to be handled with care, has to be installed with some difficulty, and it is not easy to clean. Also, it is of flat slab shape without bowel and water seal trap that prevents fermentation odours from reaching the latrine room. Moreover, its price of LE 20 is still far from the reach of the financial ability of indigent rural residents.

Plastic latrine pans locally available in the market have proved to be successful when used in rural areas and isolated communities. They are manufactured locally keeping in view the disadvantages known in other types of latrines. The pan is made of attractive colour of plastic, light in weight (less than 2 kgs), smooth to touch, and inexpensive with a price of not more than LE 10. It is easy to transport, instal and clean even without water flushing. Its water seal elbow provides protection from fermentation odours emanating from the pit; it has a good looking shape and it can be used more than once without breakage or deformation. It can be used in both temporary and permanent superstructures whether made of either simple or ordinary building material.

Accordingly, it is recommended to introduce the locally-produced plastic latrine pans for use in rural areas. Also, it can serve efficiently in rural public buildings such as mosques, schools, public lavatories, government offices, recreational areas and similar places that require durable light latrines, easily transported, installed, and cleaned, especially where water is scarce. Moreover, it is an inexpensive latrine pan that can be afforded by all. Further, the use of a new plastic latrine pan will encourage its users to adopt hygienic habits. The plastic pan has the following advantages.

- (1) It is durable and can withstand any human weight.
- (2) It is light since its total weight is less than 2 kg as compared to the weight of the concrete slab latrine which is 135 kgs.
- (3) It can be transported easily.
- (4) It can be installed easily, whether directly above the pit or adjacent to it.
- (5) It can be installed, taken off, and reinstalled more than once without any breakage or deformation.
- (6) It is cleaned easily with little water where there is no flushing system.
- (7) It is cheap compared to other models since its price does not exceed LE 10.00, while that of the concrete slab is at least twice as much.

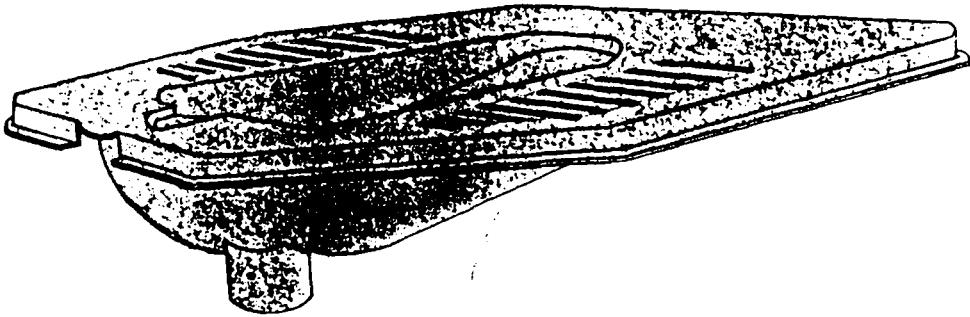

## THE NEW PLASTIC LATRINE

INEXPENSIVE

EASY TO CONSTRUCT

EASY TO CLEAN

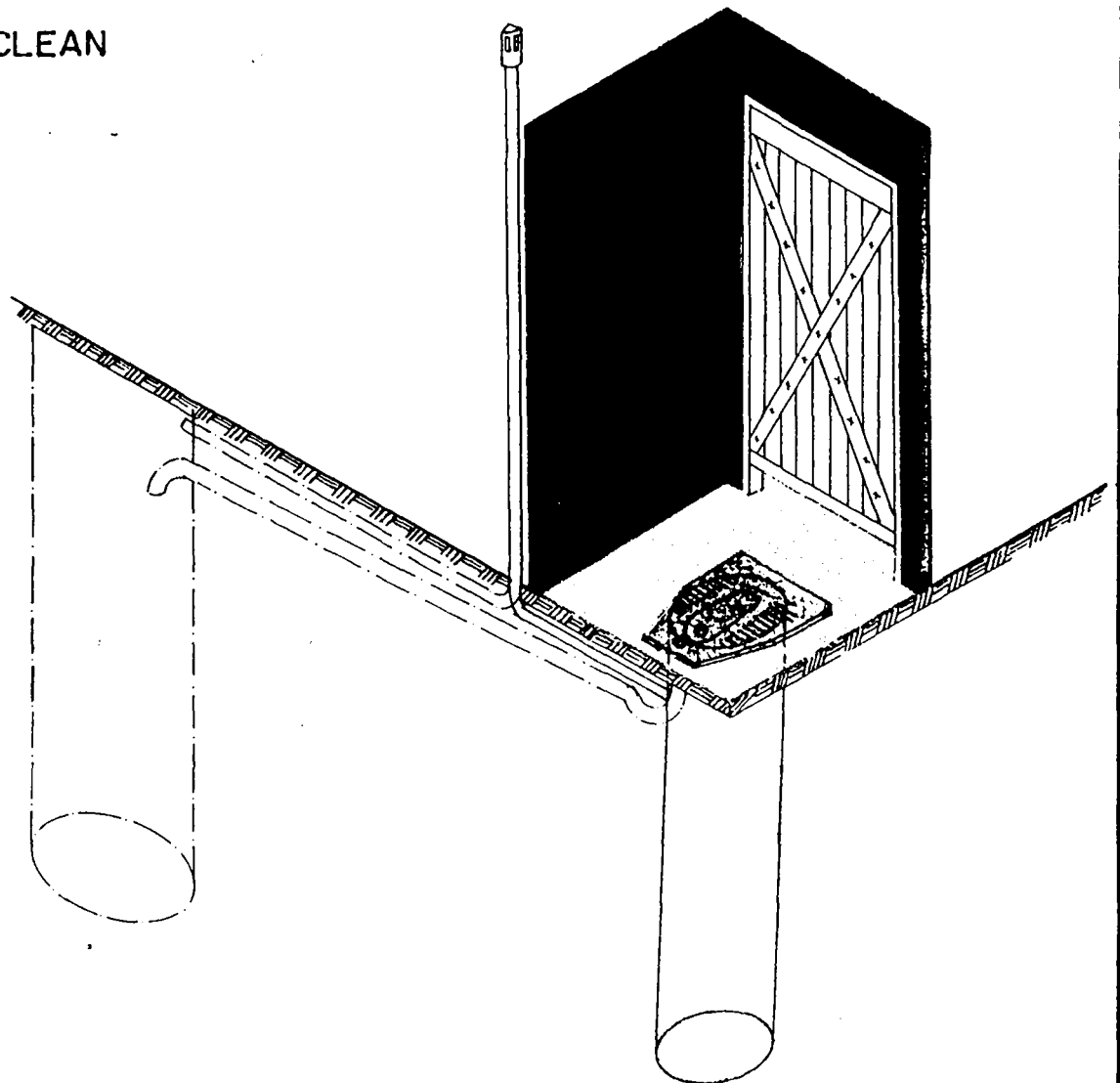

TABLE 1  
KNOWN LOCAL PLASTIC MANUFACTURERS\*

No.	NAME	ADDRESS	RESPONSE
1	Alexandria Plastic Industries Co.	Sidi Bishr - Railway Station St. No. 593 - Alexandria	C
2	Middle East Plastics - "Zaki Farag & Co."	Ahmed Abu Soliman St. - Slouf Alexandria	C
3	Egyptian Plastic & Electricity Works	Victoria - Alexandria	C
4	Universal Company for Plastic Industries	Old Road - ElAwaid - Alex.	C
5	El Sharif Plastic Factories	24 Abu Simbil St., Heliopolis Cairo	C
6	Medical Packing Company	47 St., Industrial District - Abbasia, Cairo	C
7	National Plastic Company	15 Emad ElDin St., Cairo	C
8	Saad Hanna Sons Company	10 Kamil Sidki St., Faggala, Cairo	C
9	International Plastic Company	New Manshia - Quabbary Road - Alexandria	NC
10	Modern Plastic Industries	334 Mostafa Kamel St., Ghobrial - ALEXandria	NC
11	Helel Plastic	143 Ghobrial Market - Station St., Alexandria	NC
12	Romany Plastic	2 Morocco St., Ragheb - Alex.	NR
13	Al-Ahram Company for Plastic Products	122 ElGalaa St., Cairo	NR
14	Plastica Company	9 El Gazeara ElWesta St., Zamalek, Cairo	NR
15	Nile Company for Plastic Manufacturing	12 Mohamed Sidki St., Hoda Shaarawy, Cairo	NR
16	Abo El Dahab Plastics	17 Soliman El Halaby St., Cairo	NR
17	Safa Plast	Km 16 Cairo Alex Desert Road	NR
18	Shanty Plastics Company	29 Merghany St., Heliopolis, Cairo	NR
19	Maguid Company for Plastic Manufacturing	9 Mohamed Hassona St., Heliopolis, Cairo	NR
20	Lashean Plastic Company	22 Nehro St., Heliopolis, Cairo	NR
21	Plastic Star Company	Bahteam Road, Cairo	NR
22	Rafia Plast	41 Abdel Khalek Tharwat St., Cairo	NR
23	Febro Plastic Company	Industrial Zone, Cairo Alex Desert Road, Cairo	NR
24	Arabco Plast	4 Mohamed El Mahdi St, Goulf, Heliopolis, Cairo	NR
25	Bakeer Plast Company	26 Sharief St., Cairo	NR

\* Reference: Industrial Directory - AL Ahram Paper and Press.

C - Capable.

NC - Not Capable.

NR - No Response.

TABLE 2  
COMPANIES CAPABLE OF MANUFACTURING IMPORTED SAMPLE PLASTIC LATRINE PAN

No.	Producer	Moulds Providing or cost in L.E.	Unit Price L.E.	Sector
1	Egyptian Plastic & Electricity works - Alex	To Be Provided	6.05	Public
2	National Plastic Company - Cairo	To Be Provided	7.50	Public
3	Alexandria Plastic Industries - Alexandria	80,000 - Elbows to be provided	7.50	Private
4	Universal Companies for Plastic Industries Alexandria	50,000	11.00	Private
5	Middle East Plastic "Zaki Farag & Co." Alexandria	150,000	8.0	Private
6	Saad Hanna Sons Company - Cairo	To Be Provided	7.00	Private
7	El Sharif Plastic Factories - Cairo	109,752	8.50	Private
8	Medical Packing Company - Cairo	70,000	9.50	Public

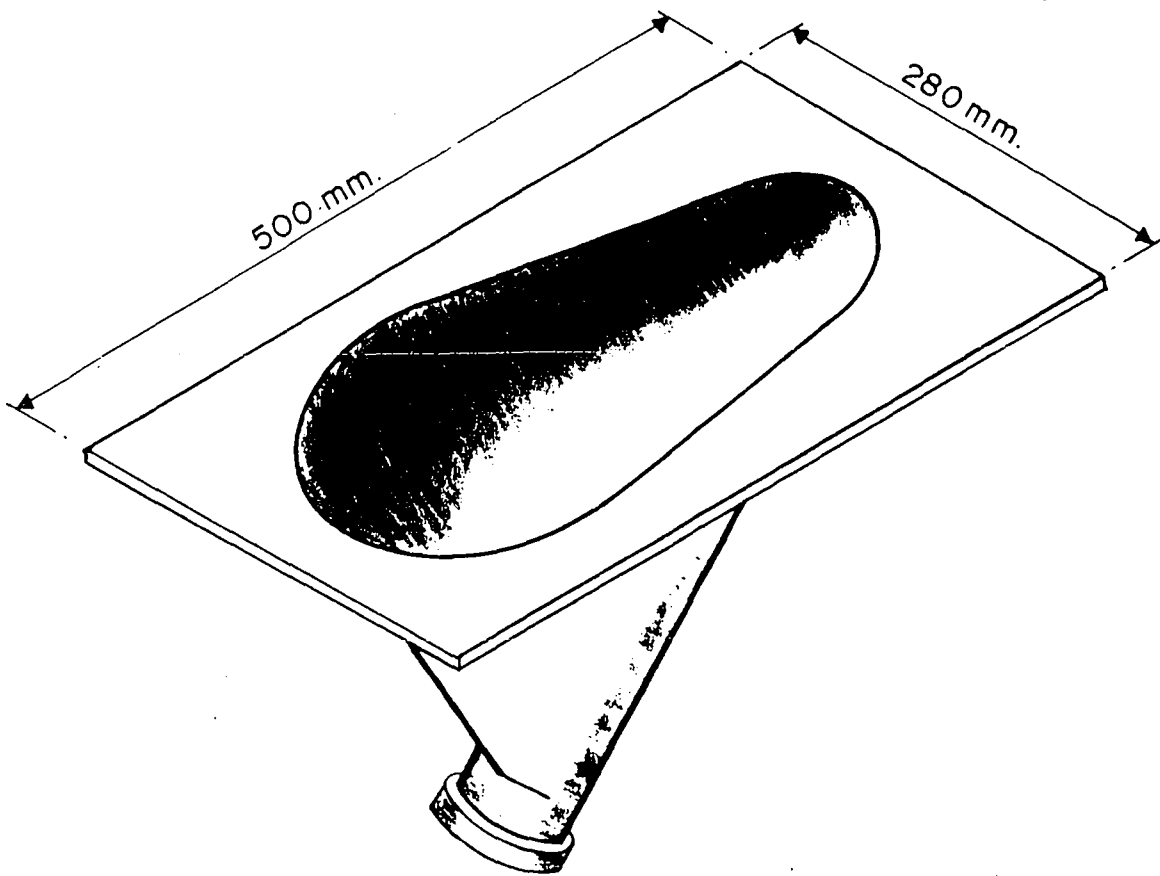

FIGURE ( I )

ISOMETRIC VIEW OF THE IMPORTED  
SAMPLE PLASTIC LATRINE PAN

MATERIAL : HIGH DENSITY POLYETHYLENE.

WEIGHT : 750 GRAMS.

COLOUR : WHITE

PRICE : LE. ( 6.05 - 11.0 ) = AVERAGE: LE. 8.5

SCALE 1 : 5



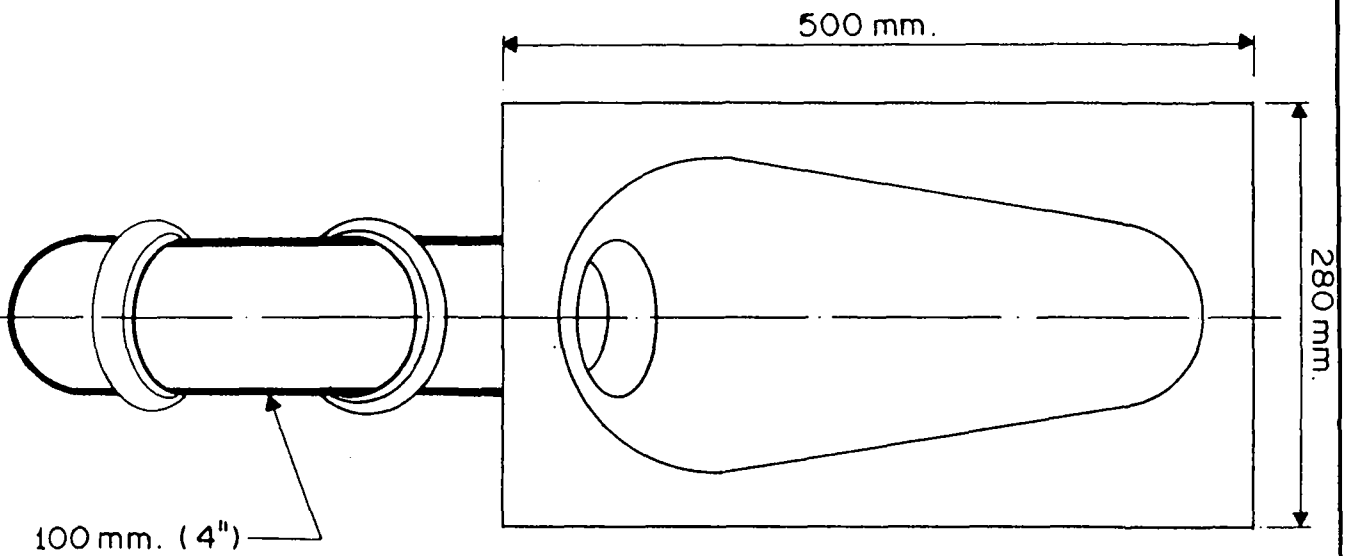

PLAN  
Scale 1 : 5

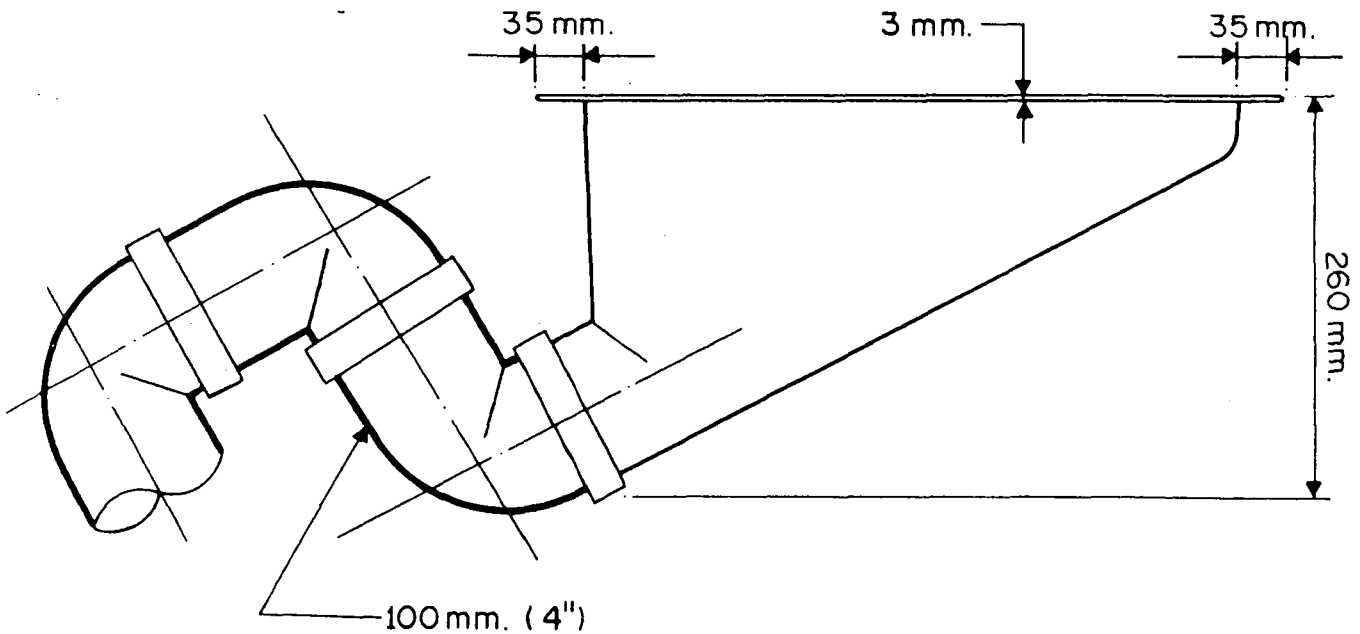

ELEVATION  
Scale 1 : 5

**FIGURE 3**  
**IMPORTED PLASTIC LATRINE PAN SAMPLE**  
**WITH MODIFIED OUTLET OF FOUR INCHES**

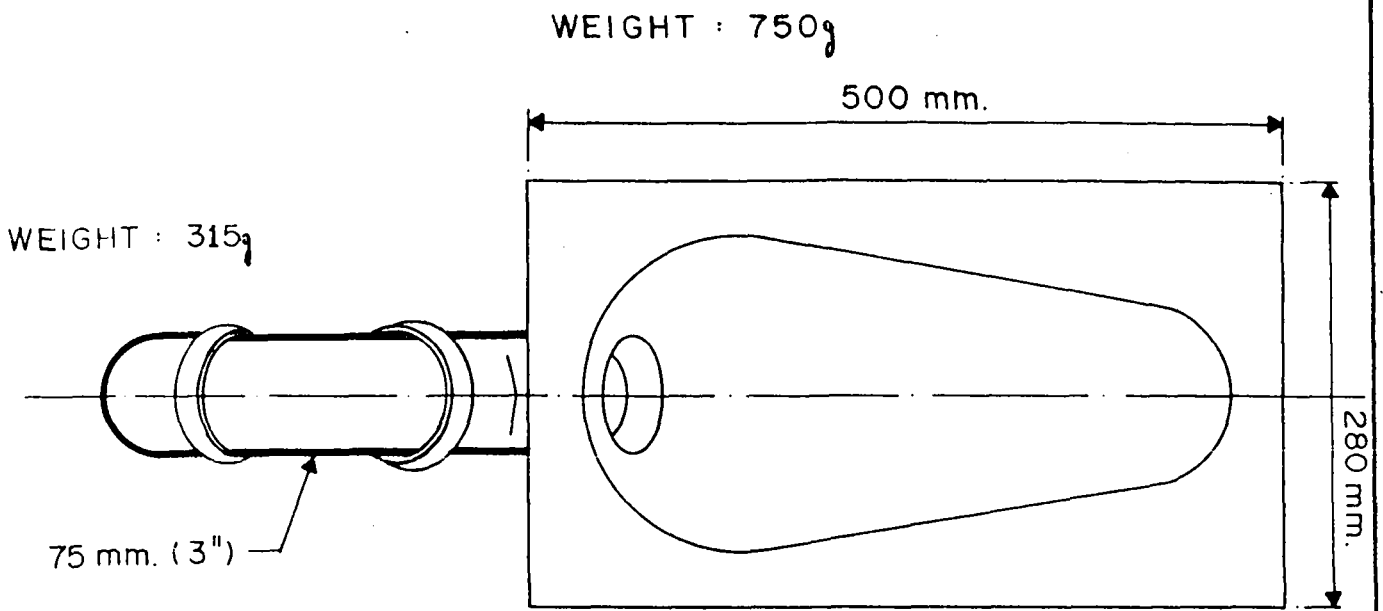

PLAN  
Scale 1 : 5

COLOUR : WHITE

MATERIAL : HIGH DENSITY POLYETHYLENE (HDPE)

PRICE : LE. 8.5 + DEPRECIATIOF OF MOULDS.

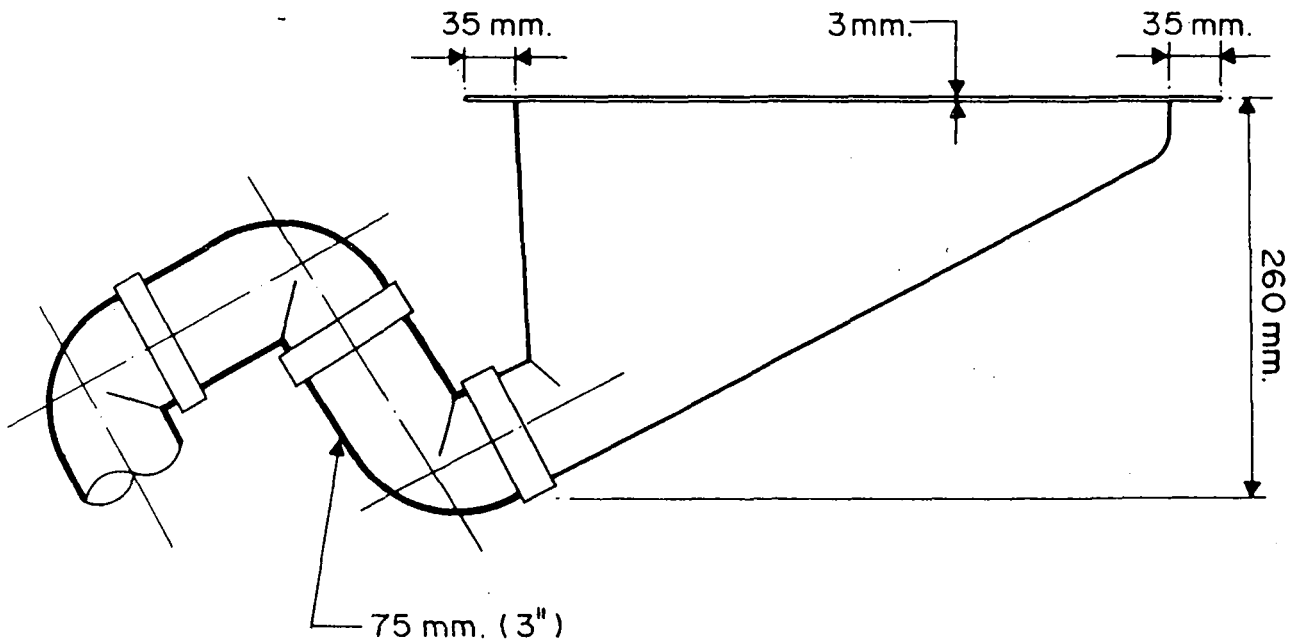

ELEVATION  
Scale 1 : 5

FIGURE 2

IMPORTED PLASTIC LATRINE PAN SAMPLE

WOODEN MOULD FOR CASTING  
CONCRETE LATRINE SLABS

قوالب خشب لصب تخطيط فرسانه للبرعاض

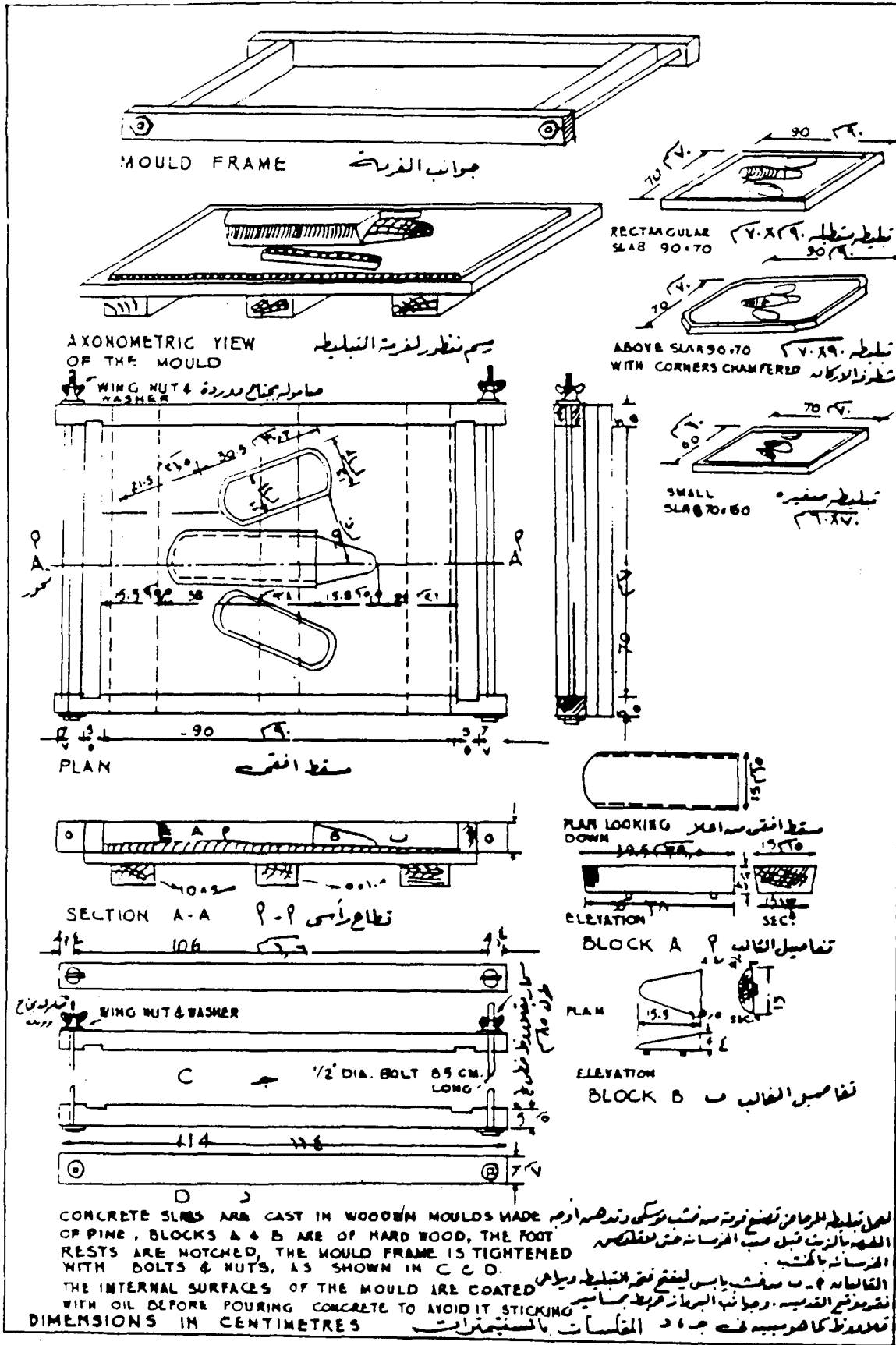
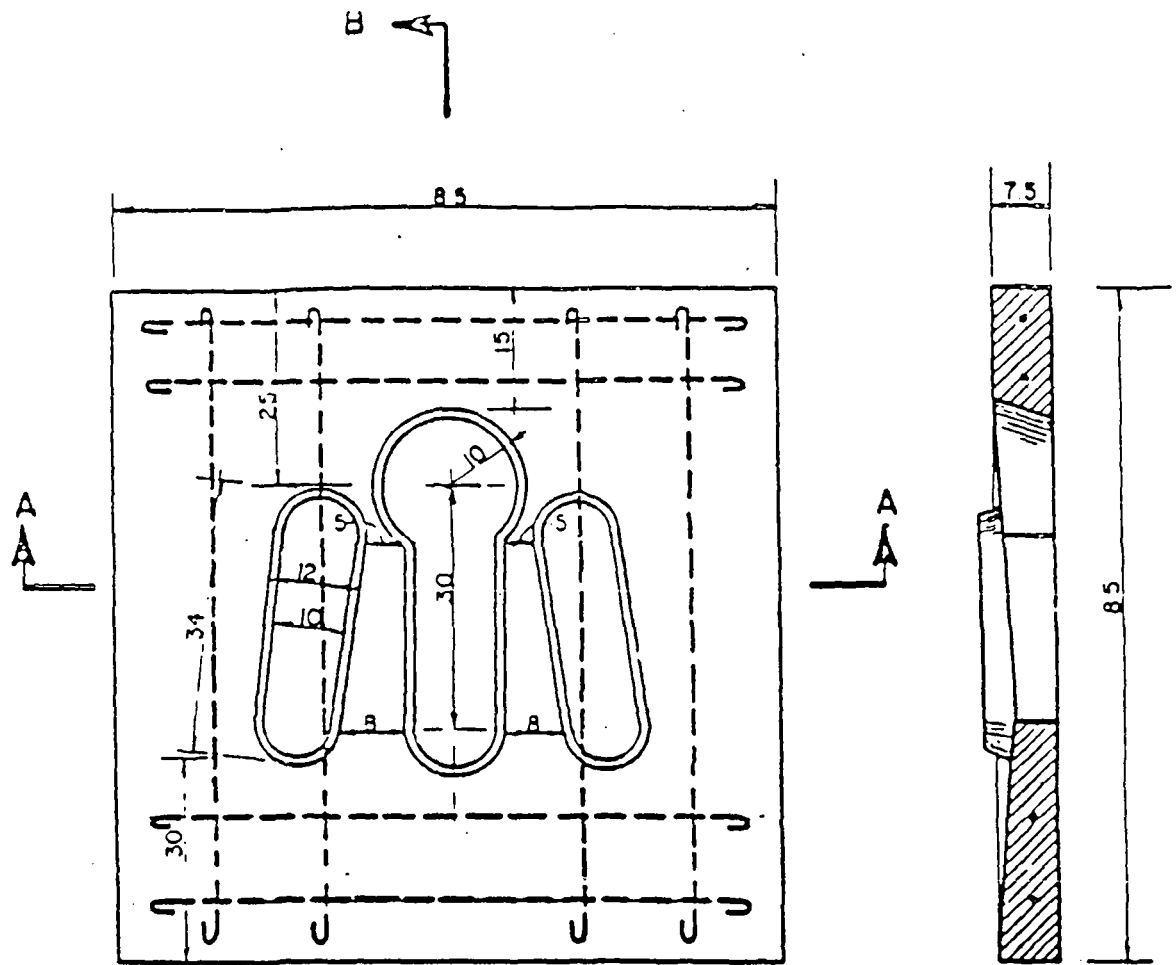

FIGURE 4

MOULD FOR CASTING CONCRETE SLABS  
IN THE '50s



WEIGHT : 135 Kg.  
 PRICE : LE. 20

**PLAN**

**SECTION B-B**

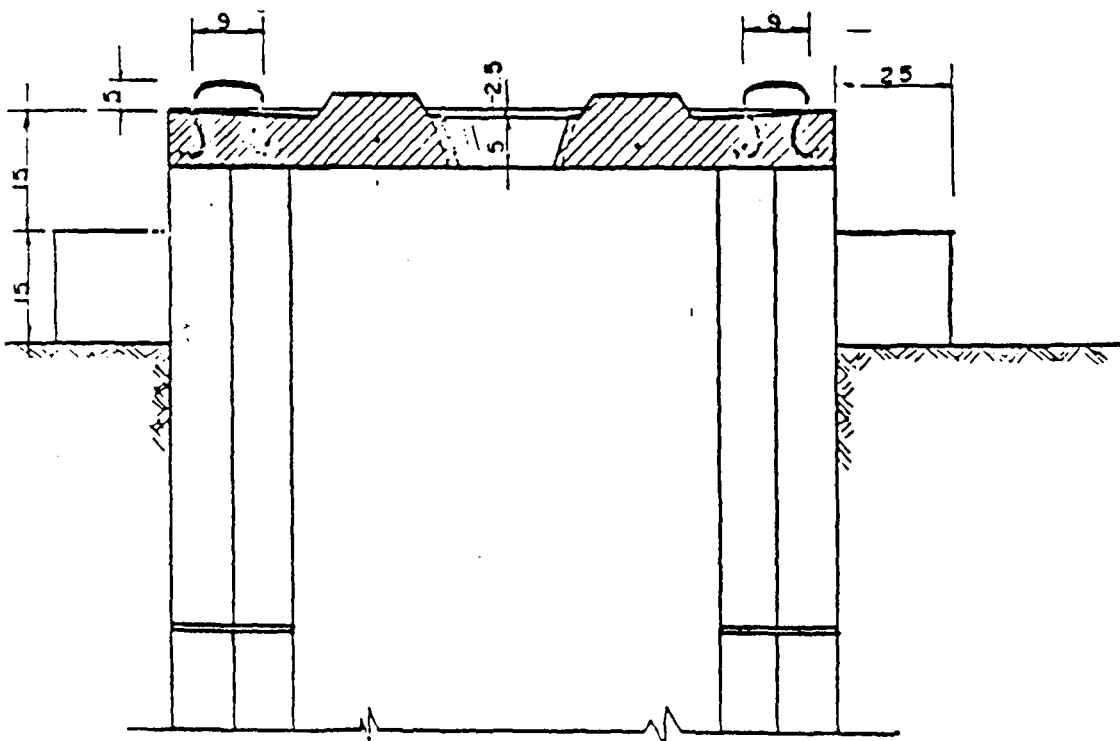

**SECTION A-A**

FIGURE 5

SQUARE PLAN: CONCRETE LATRINE SLAB

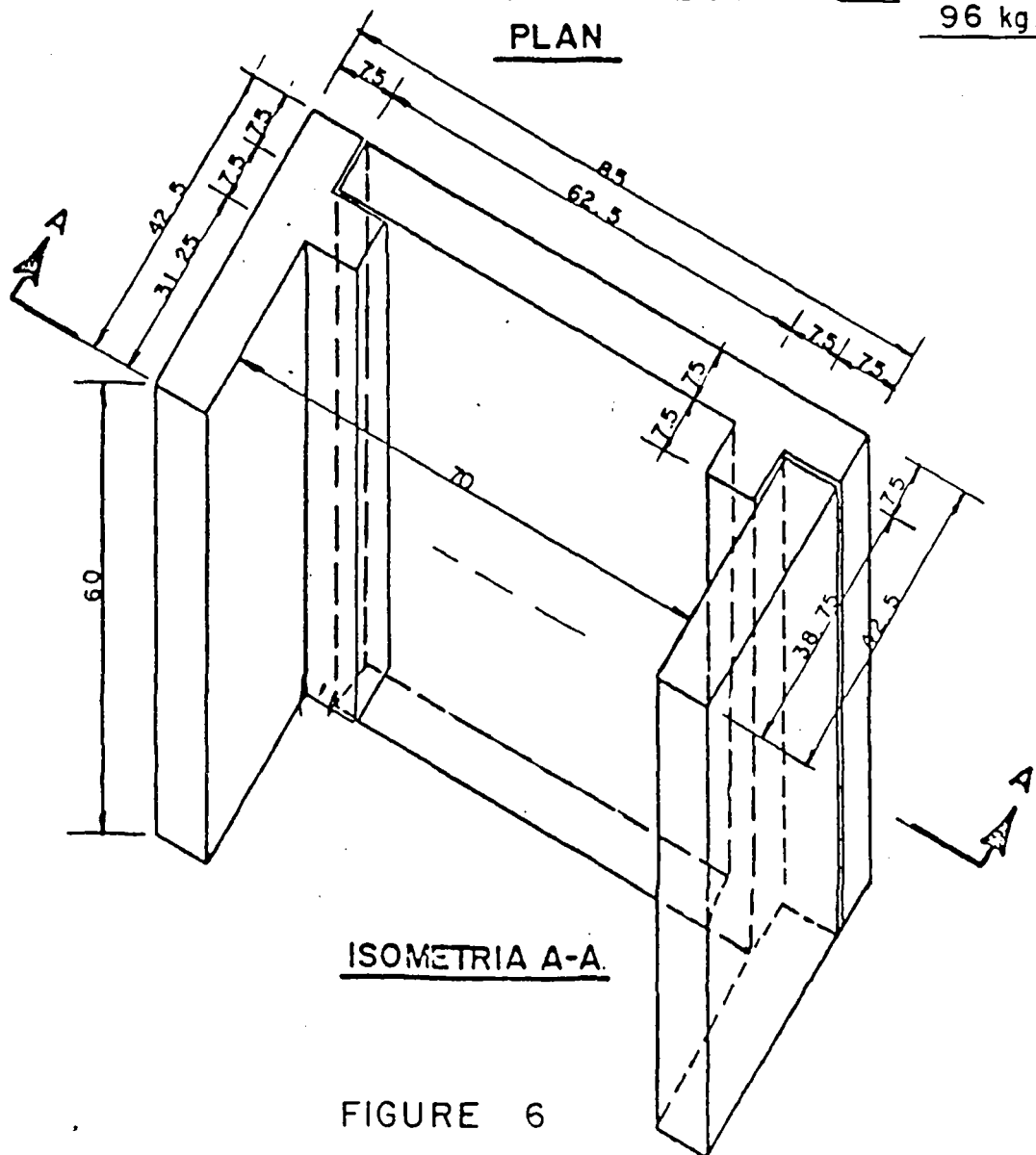
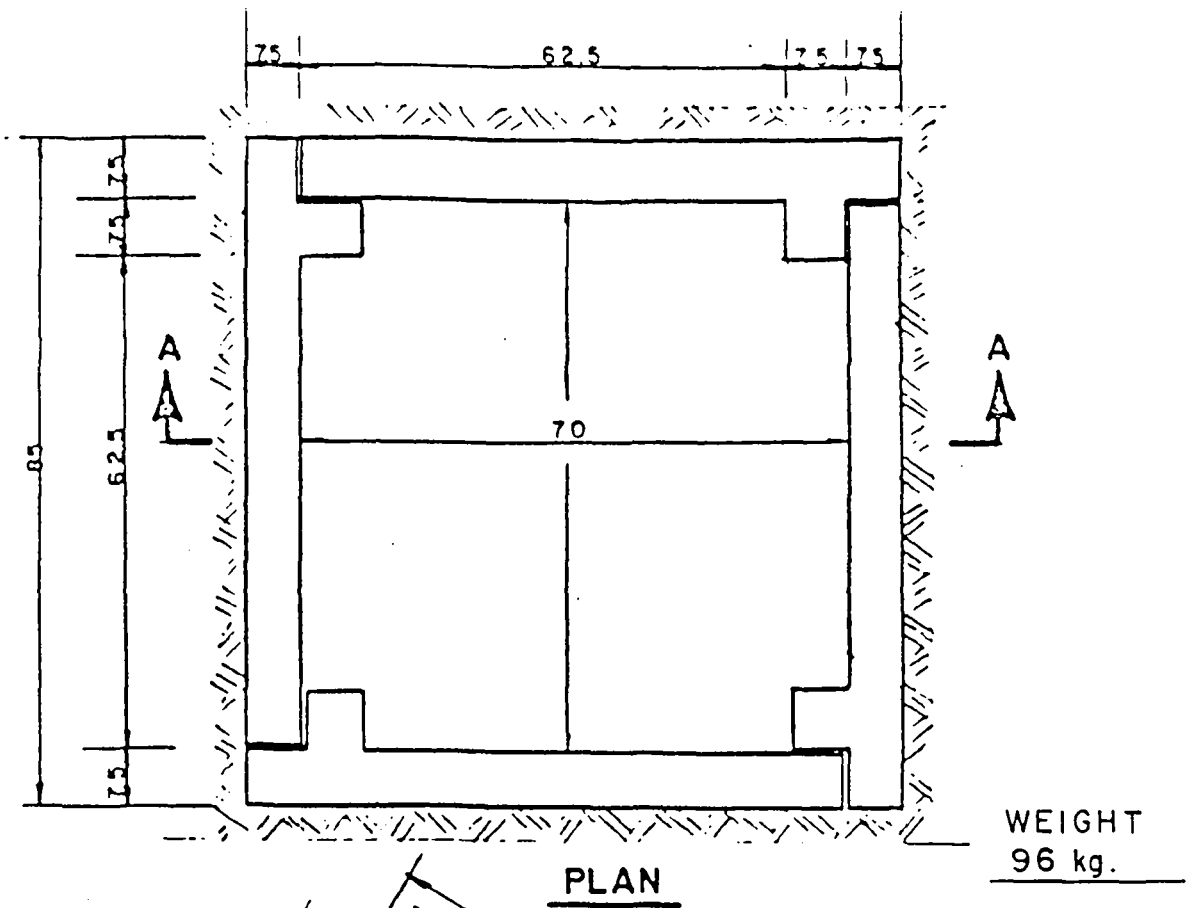
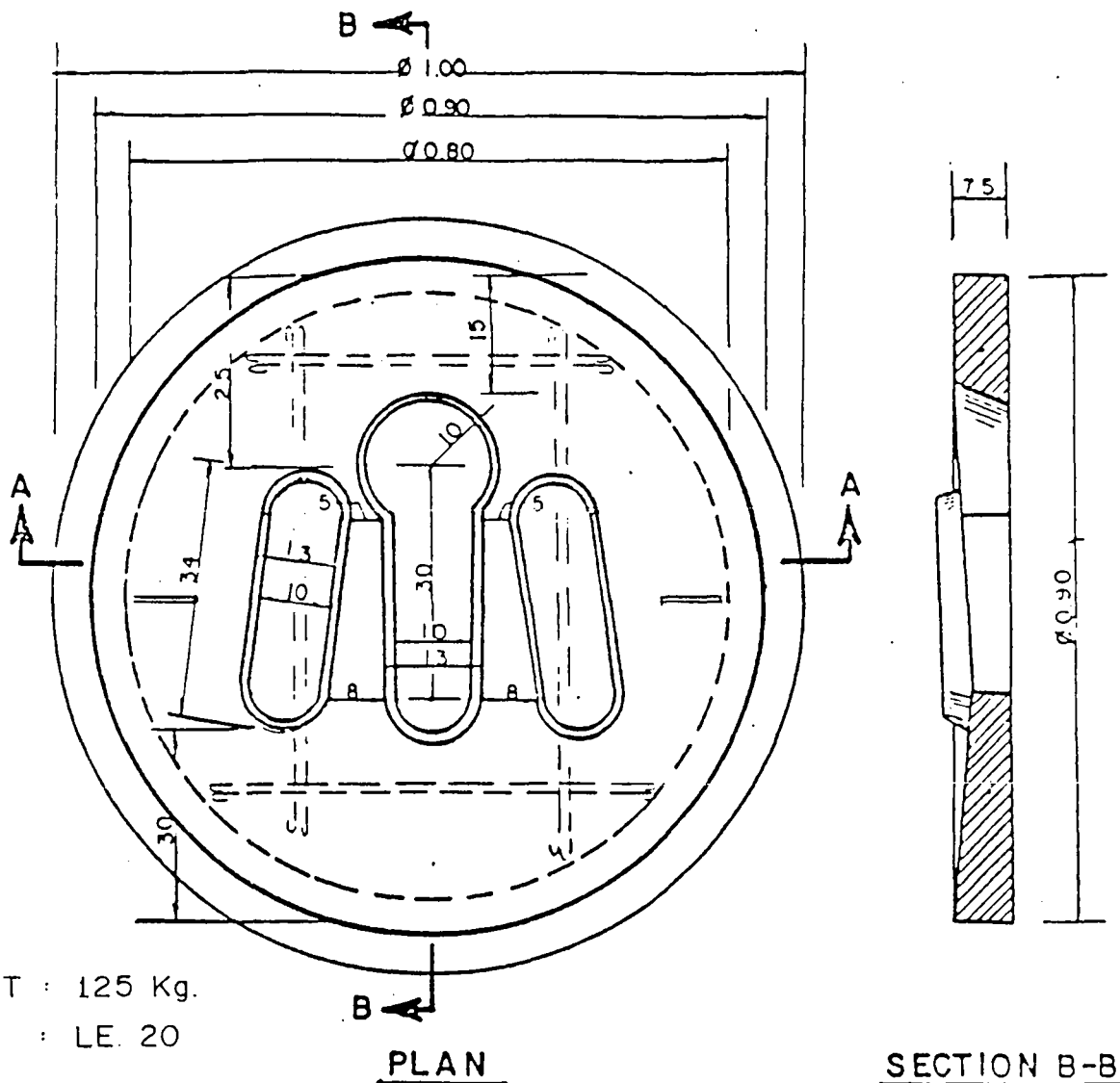

FIGURE 6  
 SQUARE PLAN: CONCRETE LATRINE SLAB.



WEIGHT : 125 Kg.  
 PRICE : LE. 20

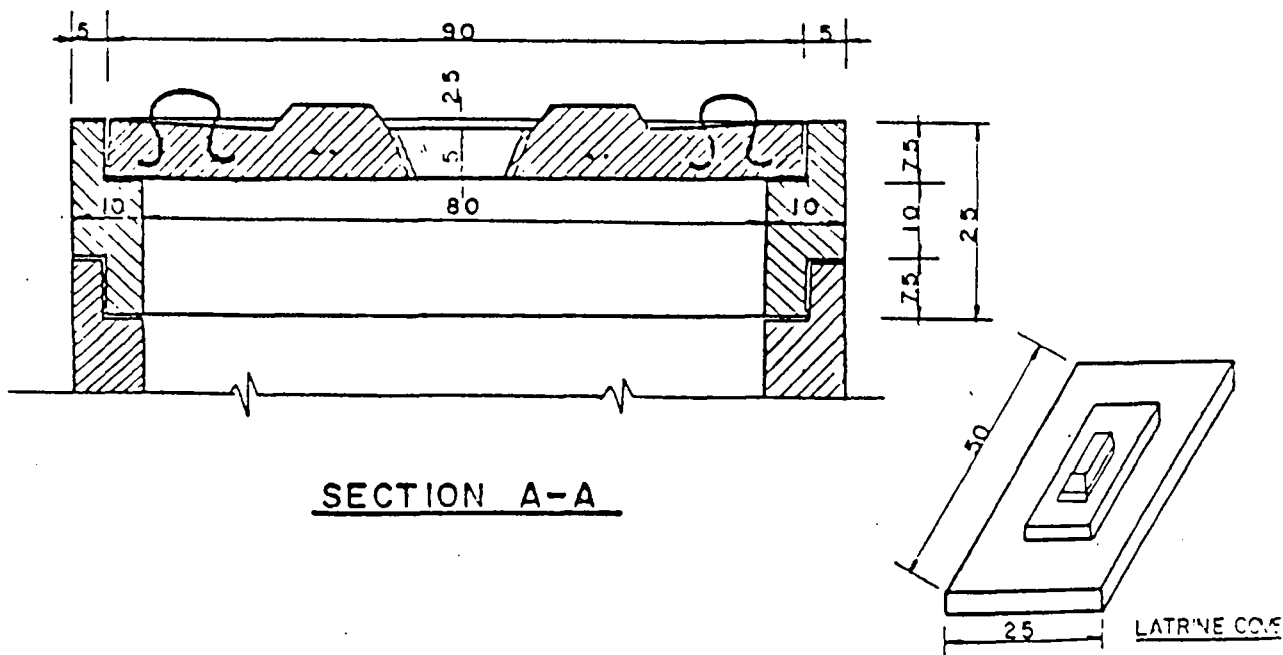

FIGURE 7

CIRCULAR PLAN: CONCRETE LATRINE SLAB

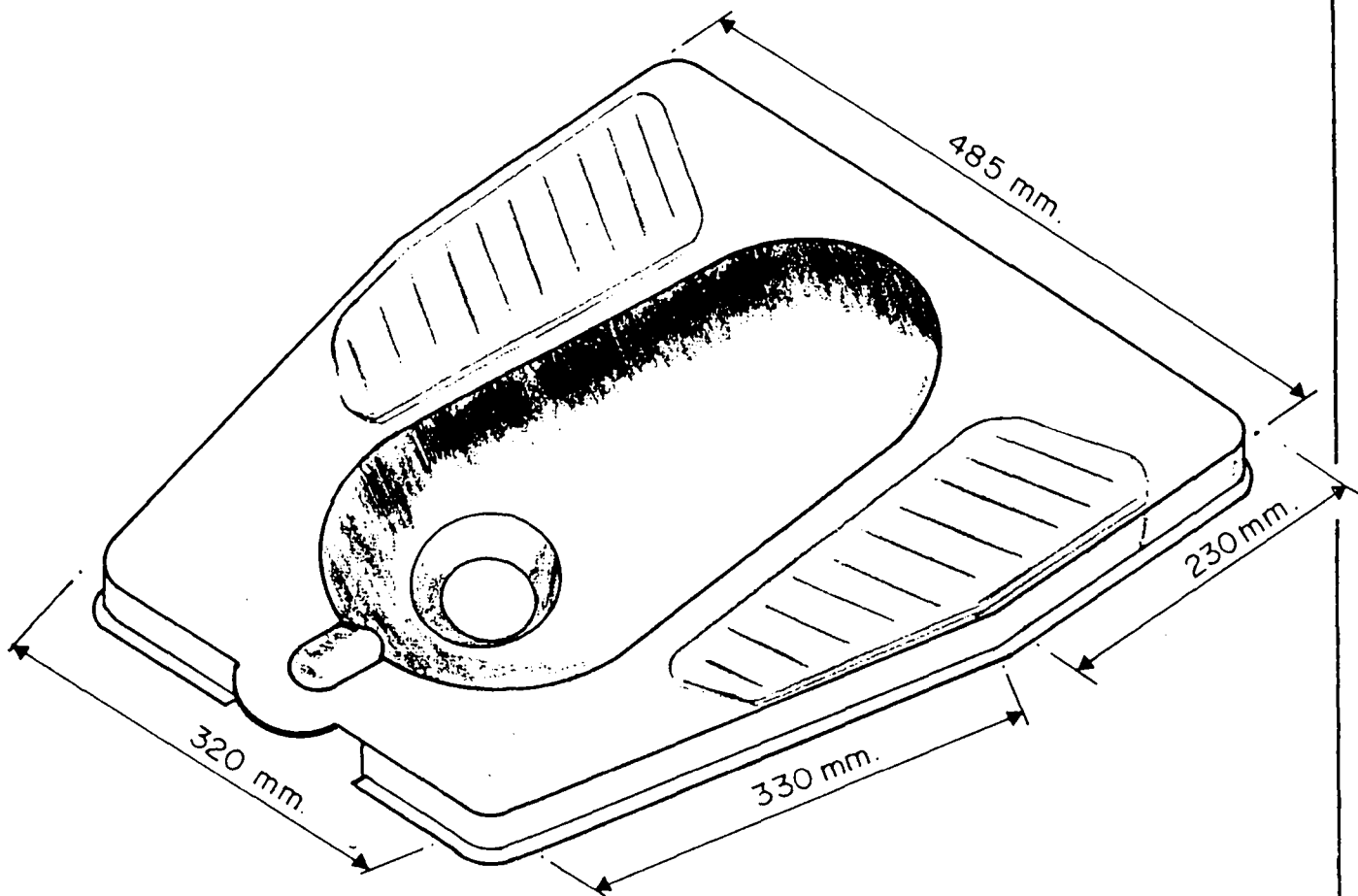
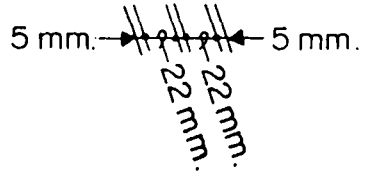
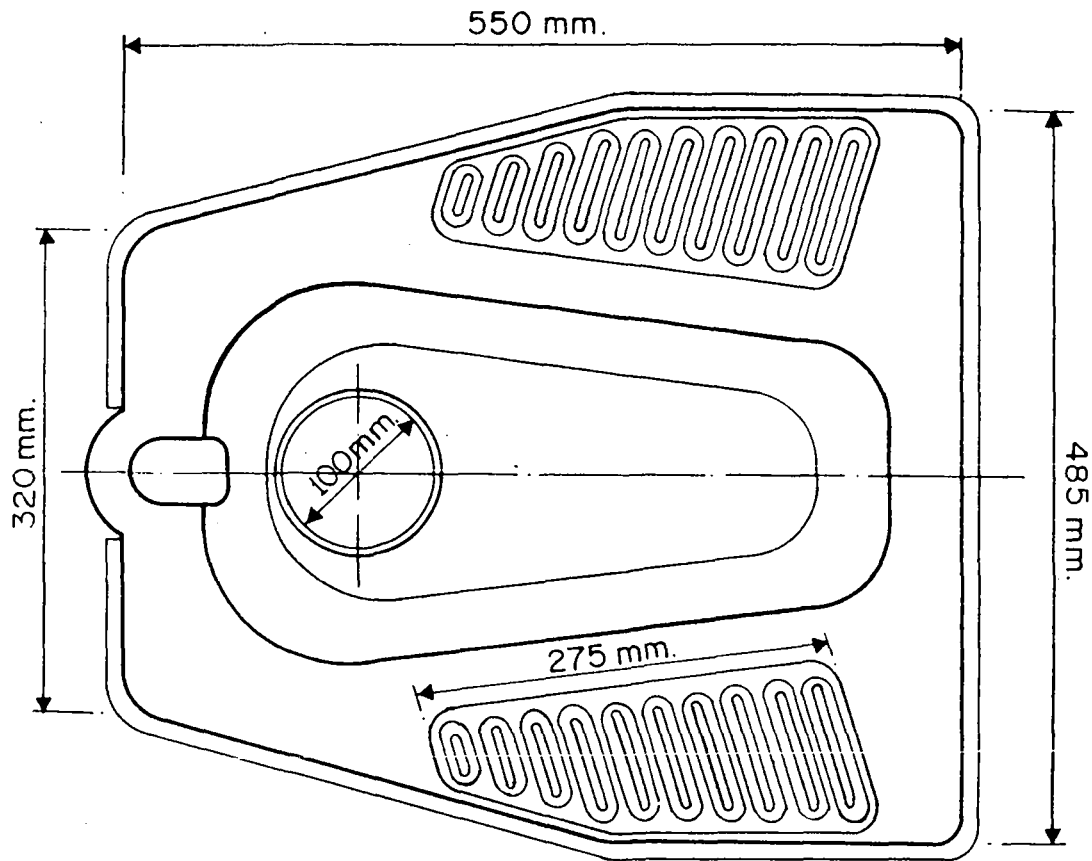

FIGURE 8

ISOMETRIC VIEW OF THE LOCALLY  
MANUFACTURED PLASTIC LATRINE PAN

- MATERIAL : POLYPROPYLENE
- WEIGHT : 1860 GRAMS
- COLOUR : PALE GREEN, RED, OR BLUE
- PRICE : LE. 6.5

SCALE 1 : 5



P L A N  
Scale 1 : 5

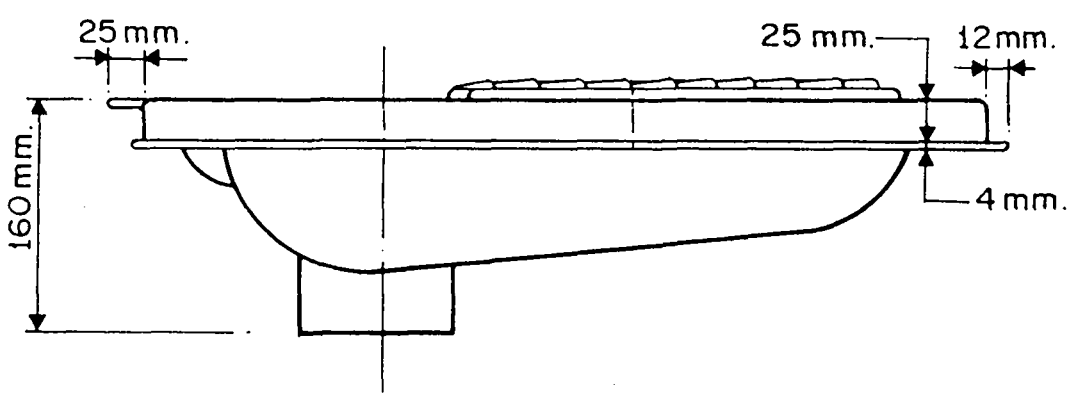

ELEVATION  
Scale 1 : 5

FIGURE 9  
LOCALLY MANUFACTURED PLASTIC LATRINE  
PAN



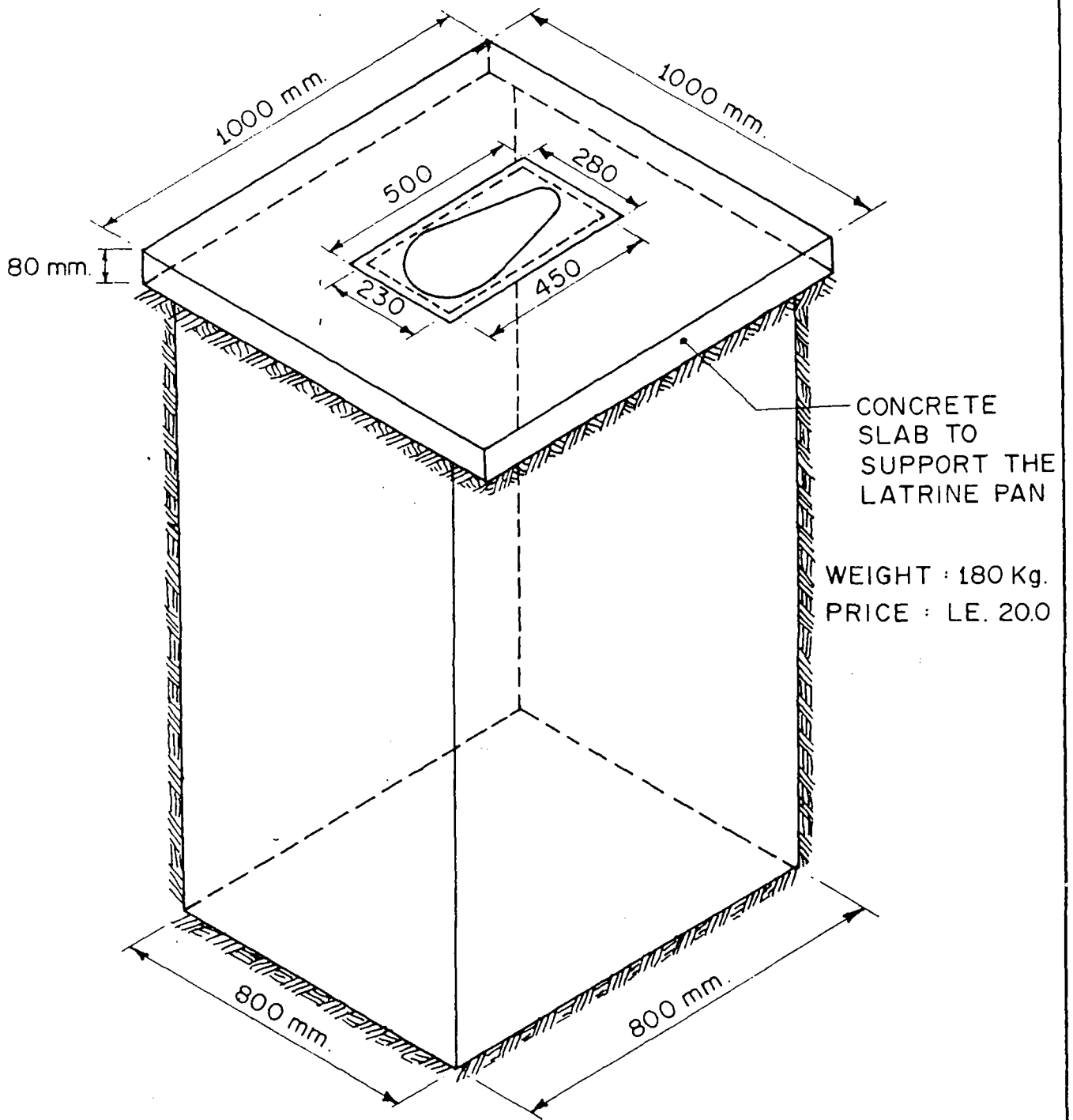
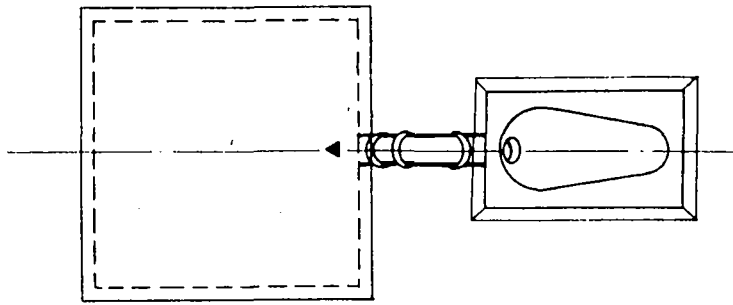

FIGURE 10

ISOMETRIC VIEW OF THE IMPORTED PLASTIC LATRINE PAN DIRECTLY ABOVE ITS PIT

SCALE 1 : 15



P L A N

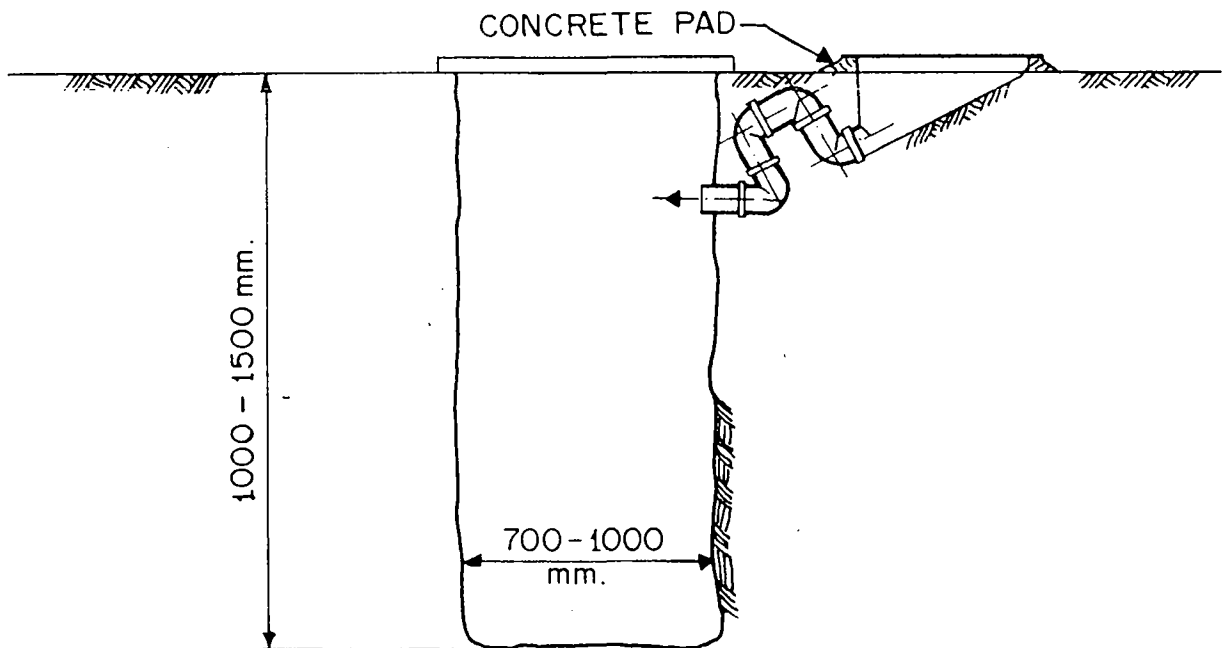

E L E V A T I O N

SCALE 1 : 20

FIGURE 11  
 PROPOSED POSITION BESIDE THE PIT FOR THE  
 IMPORTED PLASTIC LATRINE PAN

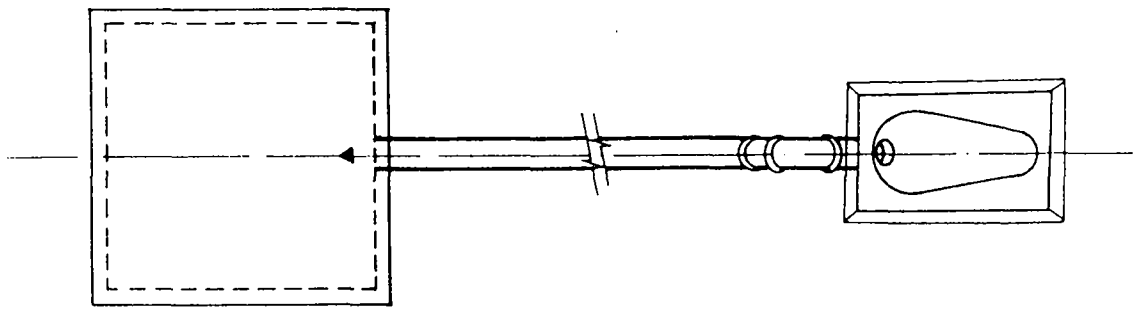

P L A N

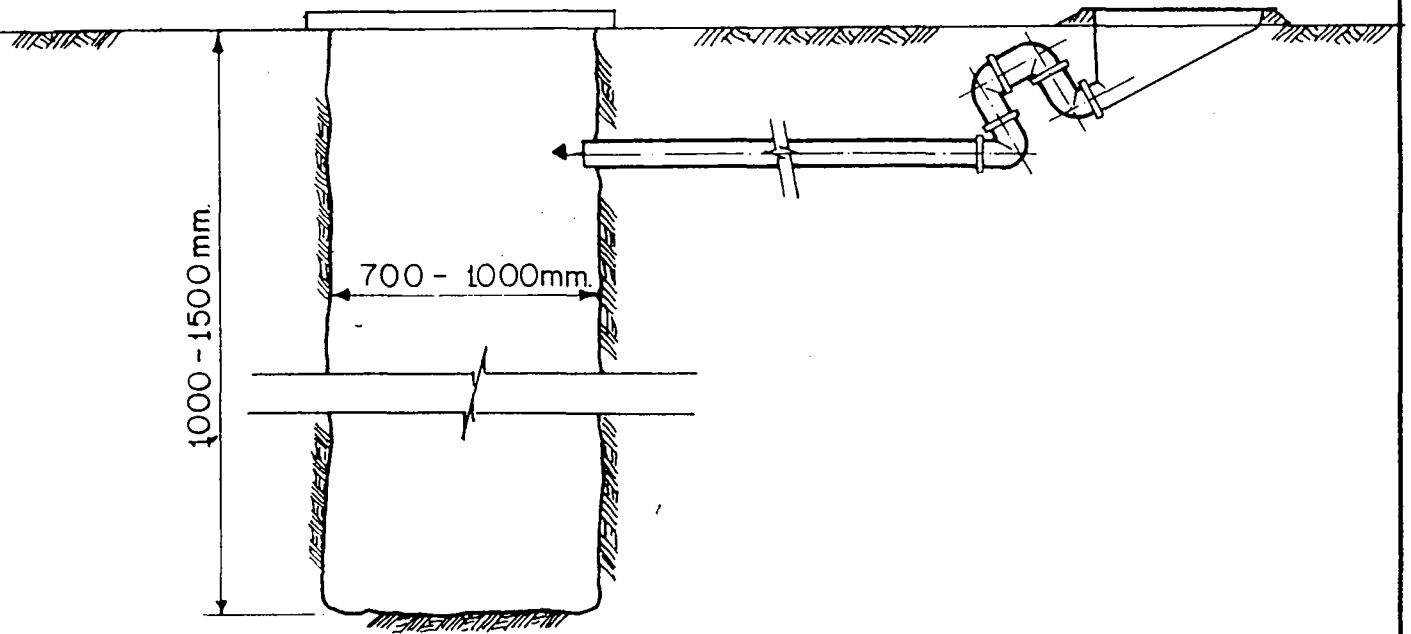

E L E V A T I O N

FIGURE 12

PROPOSED POSITION FAR FROM THE PIT FOR THE  
IMPORTED PLASTIC LATRINE PAN

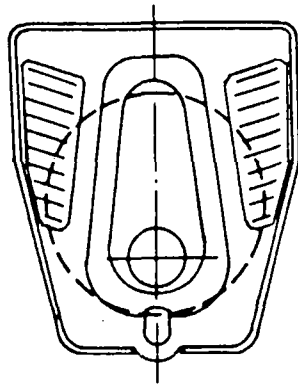

P L A N

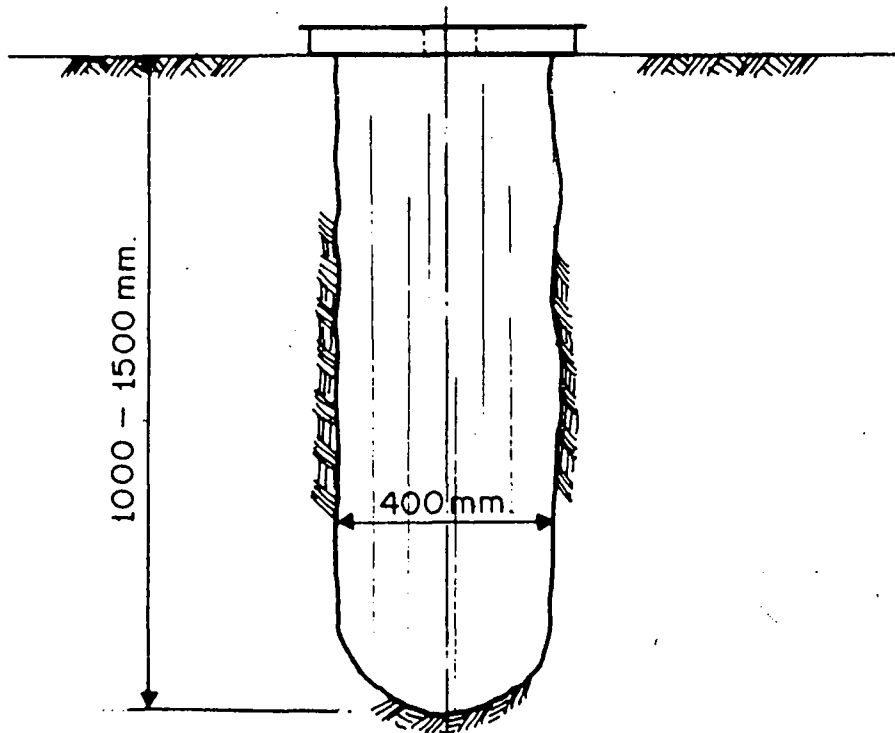

E L E V A T I O N

SCALE 1 : 12.5

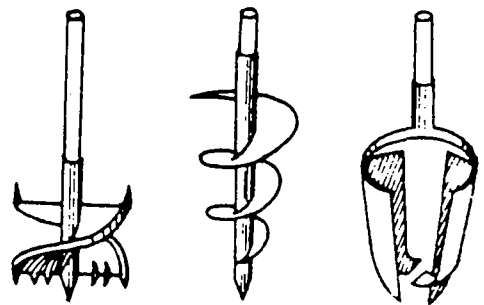

AUGERS FOR BORING

FIGURE (13)  
PROPOSED POSITION ABOVE THE PIT FOR THE  
LOCALLY MANUFACTURED PLASTIC LATRINE  
PAN

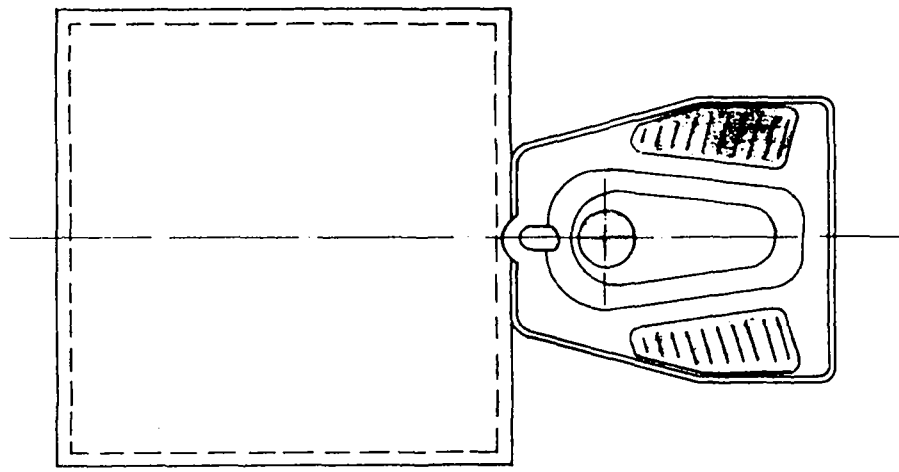

P L A N

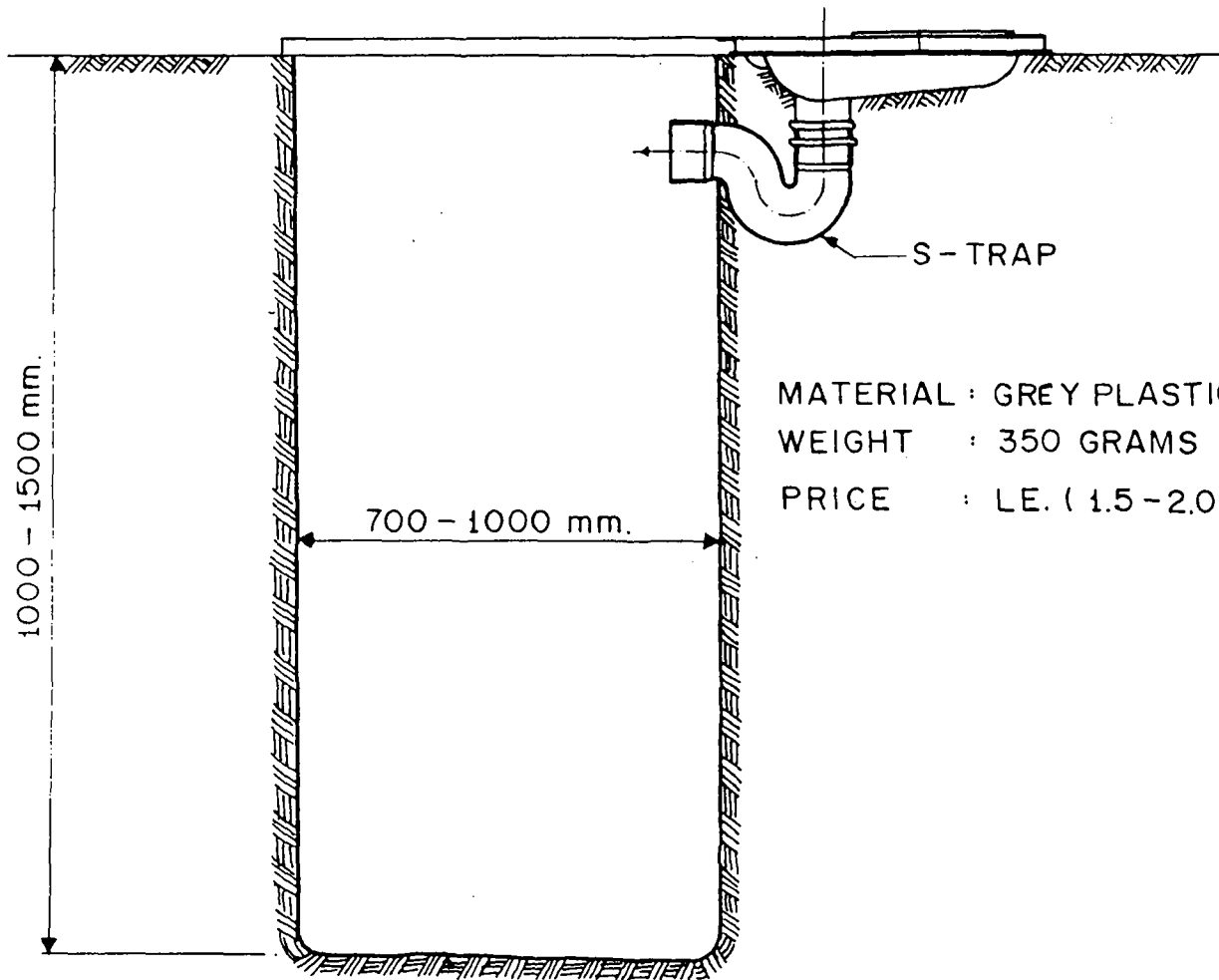

S-TRAP

MATERIAL : GREY PLASTIC  
 WEIGHT : 350 GRAMS  
 PRICE : LE. (1.5-2.0)

1000 - 1500 mm.

700 - 1000 mm.

E L E V A T I O N

SCALE 1 : 12.5

FIGURE 14

PROPOSED POSITION BESIDE THE PIT FOR THE  
 LOCALLY MANUFACTURED PLASTIC LATRINE PAN

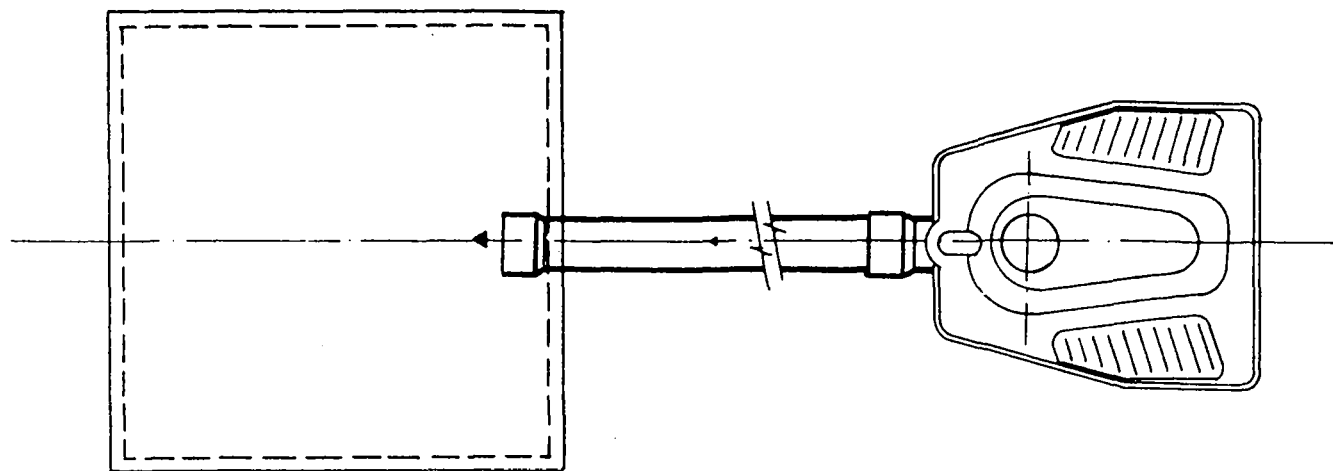

P L A N

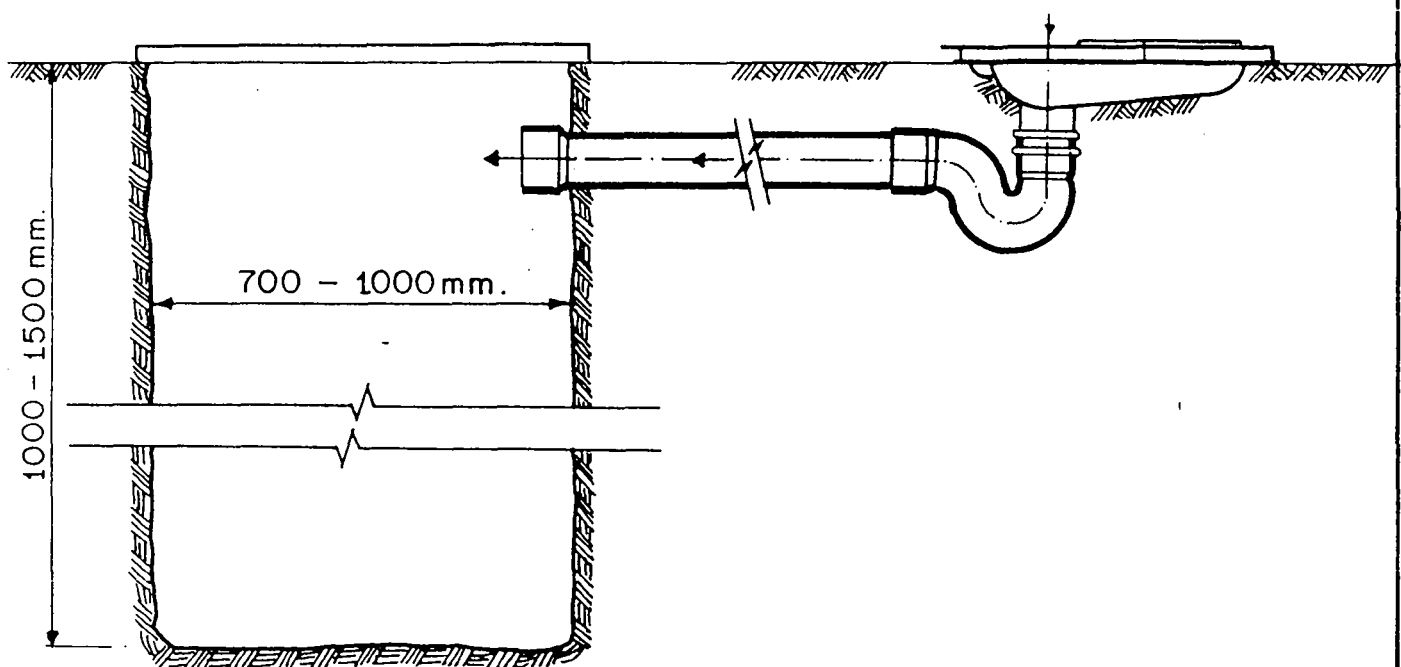

E L E V A T I O N

FIGURE 15

PROPOSED POSITION FAR FROM THE PIT FOR THE  
LOCALLY MANUFACTURED PLASTIC LATRINE PAN

SCALE 1 : 12.5

Dr. Hassan Mitwally

Consultant Engineer

Professor of Sanitary Engineering

Ex Head, Department of Environmental Health

Alexandria University

A. R. E.

Tel. { Office 5866472-840655  
Home 847377 -5461189

دكتور  
حسن ميتوالي

مهندس استشاري

أستاذ الهندسة الصحية ورئيس قسم الصحة البيئية السابق  
جامعة الاسكندرية

مكتب ٨٤٠٦٥٥-٥٨٦٦٤٧٢ } 2  
منزل ٥٤٦١١٨٩- ٨٤٧٣٧٧ }

Alexandria, \_\_\_\_\_ ألكندرية

Copy of the letter sent to Plastic Companies

Dear Mr. Chairman,

Attached is a sample of plastic latrine that was received by the Regional Office of the World Health Organization in Alexandria from abroad. It has been tried as a private latrine in rural areas and isolated communities where flushing water system is not available. The results of the experiments when carried out in other countries proved to be significantly successful to the extent that WHO is considering its introduction to be used as a private latrine in local rural areas. To do so, the device should be locally manufactured at a reasonable cost.

It will be highly appreciated if you let us know of the possibility of manufacturing such plastic latrine, typically as the attached sample, except that the diameter of the water seal accessories is 4 instead of 3 inches. The production capacity is expected to be about twenty thousand pieces a year, while the material is specified to be high density poly-ethylene. Any modifications that you think appropriate for local production and/or use will be considered.

I will pass by your office within a few days as convenient to you and as will be arranged by a telephone call to get the sample and the bid.

Thank you for your cooperation and please accept our best regards.

Truly Yours

Hassan Mitwally, Ph.D.

ANNEX 2

*Egyptian Plastic and Electricity Works*

Alexandria - Egypt

October 29, 1989

*Dr. Hassan Mitwally*

Alexandria - Egypt

*Dear Sir:*

*Reference is made to your letter on 17/10/1989 on the subject of a plastic latrine production, here by below our bid submitted:*

*1- The latrine is made of HDPE high density polyethylene with a weight of 750 grams.*

*2- A plastic elbow of 4 inches diameter.*

*Please, be informed that we are capable to produce these parts in our factories in case you provide us with the needed moulds as specified by us.*

*With respect to item No. 1 the price will be L.E.4.25 per unit for 20,000 units, while the price for item No. 2 will be L.E.1.80*

*Samples would be provided as soon as we receive the moulds and production will start 2 months after notification. If the weights are different, the prices will differ accordingly.*

*This bid is valid for six months, waiting for your reply, we remain*

*Truly Yours,*

*Hazam El Kholly*

*Vice Chairman for Plastic Sector*



ANNEX 3

Medical Packing Company  
Calro - Egypt  
November 7, 1989

Dr. Hassan Mitwally  
Alexandria - Egypt

Dear Sir:

Reference is made to your letter dated 10/10/1989 with respect to your request to submit a bid for manufacturing a plastic latrine at a capacity of 20,000 units per year. This will need to cast four molds as latrine components.

Please, be informed that we are capable of manufacturing the required items according to the following prices:

- 1- The moulds will cost L.E.70,000.00 and can be completed after 6 months.
- 2- The latrine with its components that include latrine base, 2 big elbows, 1 small elbow, and 3 washers will cost L.E.9.50

Conditions for supply

- 1- Supply will be 2 months after completion of the moulds.
- 2- All costs will be paid in advance.
- 3- Final check and delivery are in our stores.
- 4- This bid is valid for 15 days.

Waiting for kind reply, we remain

Truly Yours,

M.S.Gabbarah  
Vice Chairman for Marketing

ANNEX 4

Alexandria Plastic Industries Co.

Sidi Bisher - Alexandria

Egypt

October 21st, 1989

Dr. Hassan Mitwally  
WHO World Health Organization  
Alexandria - Egypt

Dear Sir:

Reference is made to your letter by the beginning of this October, with respect to plastic latrine production of HDPE High Density polyEthylene as the attached sample to your letter, please be informed of the following:

1- It is possible to produce the required latrine at a cost of L.E.7.50 per unit in addition to the cost of the mould which equals L.E.80,000. The elbow is not included in the agreement.

2- There is a plastic latrine of our factory production and it costs L.E.6.50 in addition to the water seal trap which equals L.E.1.5 - 2.0 and it is available in the local market.

This bid is valid for one month only.

Truly Yours,

A.H. Saleh  
Manager

ANNEX 5

Universal Company For Plastic Industries

Alexandria - Egypt

October 25, 1989

Dr. Hassan Mitwally

Alexandria - Egypt

Dear Sir:

Reference is made to your letter on 17/10/1989 on the subject of a plastic latrine production, please be informed that:

- 1- We have the capability of the required production.
- 2- You have to pay the cost of the moulds which will be L.E.50,000
- 3- The subject unit is made of high density polyethylene and its price is L.E.11.00 .

However, we advise that the latrine will be manufactured of the ABS material and its price will be L.E.16.00.

Waiting for your reply, we remain

Truly Yours,

H.H.Mady

Board Manager

ANNEX 6

Middle East Plastic Company "Zaki Farag"

Alexandria

Egypt

October 26th, 1989

Dr. Hassan Mitwally

WHO World Health Organization

Alexandria - Egypt

Dear Sir:

Subject: Plastic Latrine

Reference is made to your letter to us by the beginning of October on the above mentioned subject, please be informed that:

1- The latrine can be manufactured in our factories by casting a special mold which costs L.E.150,000.00, and it should be paid by the client.

2- The unit price of the latrine will be L.E.8.00

This bid is valid for one month only.

Truly Yours,

Zaki Farag

Manager

ANNEX 7

Saad Hanna Sons

Calro - Egypt

October 4, 1989

Dr. Hassan Mitwally  
Alexandria University  
Alexandria - Egypt

Dear Sir:

We have the honour to submit our bid at a price of L.E.7.00 for the production a HDPE high density polyethylene latrine as the sample submitted.

We can produce, if needed, 60,000 units per year.

Hoping that this suits you we will remain

Truly Yours,

Saad Hanna Sons Co.

ANNEX 8

*Al Sherif Plastics Factories*

*Helioplis - Cairo*

*Egypt*

*November 7, 1989*

*Dr. Hassan Mitwally*

*WHO World Health Organization*

*Alexandria - Egypt*

*Dear Sir:*

*Reference is made to your letter with regard to possibility of manufacturing the plastic latrine typically as the sample we received, please be informed of the following:*

- 1- The cost of the moulds is attached as given by our moulding factory (it is L.E.109,752 and would be paid by you).*
- 2- The price of each latrine unit will be L.E.8.50*

*This bid is valid for 2 months.*

*Truly Yours,*

*Safa Abou Zaid  
Chief Engineer*

ANNEX 9

*Egyptian Company for Metallic & Eng. Ind.*

*Al Sharif Factories, Cairo*

*November 1st, 1989*

*WHO World Health Organization*

*Alexandria - Egypt*

*Dear Sir:*

*Reference is made to your request to manufacturing moulds for the plastic latrine samples provided by you, please be informed that the cost will be for:*

*1- The latrine base mould (1) L.E.77,852*

*2- Elbow No.(1) mould (2) L.E.18,700*

*3- Elbow No.(2) mould (3) L.E.13,200*

*TOTAL cost of the moulds L.E.109,752*

*Supply can be carried out within eight months after contracting and paying 75% of the price in advance.*

*This bid is valid for 15 days.*

*Truly Yours,*

*E.A.Ezzat*

*Board Member*

ANNEX 10

National Plastic Company

Calro - Egypt

August 25, 1989

Manager, Water Supply & Sanitation Support Project

WHO, Calro\*

Dear Sir:

Subject: Plastic latrine Production

Reference is made to the above mentioned subject, and due to incapability of producing the moulds in our factories, please be informed that we can produce and provide you with the subject latrine in case you provide the needed moulds, and the prices will be L.E.7.50 as total price which includes L.E.5.90 for the latrine pan, L.E.0.90 for the big elbow, and L.E.0.70 for the small one.

Waiting for your reply, we remain

Truly Yours,

A.Salem

Vice Chairman for Trades and Fairs

\* This is a translation of a letter sent to WHO, Calro, since the company (when contacted) stated that this is their answer and it is valid.



## ANNEX 11

## PERSONNEL MET AND / OR CONTACTED

No.	NAME	POST
1	Dr. Amin El Gamal	Ex. First Vice Minister, Ministry of Health, Cairo
2	Dr. Ezzat Helwa	Vice Minister, Ministry of Health, Cairo
3	Dr. Fathy Shaibet El Hamad	Vice Minister, Ministry of Health, Cairo
4	Dr. Ahmed Sarhan	Director of Environmental Health Directorate, M.H.,Cairo
5	Mr. Shokry Abu El Kamal	Director of Engineering Directorate, M.H.,Cairo
6	Mr. M.A.El Shanshoury	Director of Environmental Health Dept., M.H.,Alexandria
7	Dr. Tharwat Saleh	WHO Project Director, Cairo.
8	Dr. Amal Khairy	Professor of Primary Rural and Urban Health Care, High Institute of Public Health, Alexandria University.
9	Dr. Nermeen Mahmoud	Associate Professor of Primary Rural and Urban Health Care, HIPH, Alexandria University.
10	Dr. Osman Enan	Professor Emeritus of Vector Control, HIPH Alexandria Univ.
11	Dr. M.F. El Sawy	Professor Emeritus of Tropical Public Health, HIPH, Alexandria University.
12	Haj. Abdel Tawab Hammad	Vice Mayer - Rural Community Leader - Menofia Governorate
13	Shaikh Abdel Hady Kandeel	Vice Mayor - Rural Community Leader - Menofia Governorate
14	Haj. M.A.El Ghayesh	Mayor - Rural Community Leader - Gharbia Governorate
15	Mr.Salem Sheta	Mayor - Rural Community Leader - Gharbia Governorate

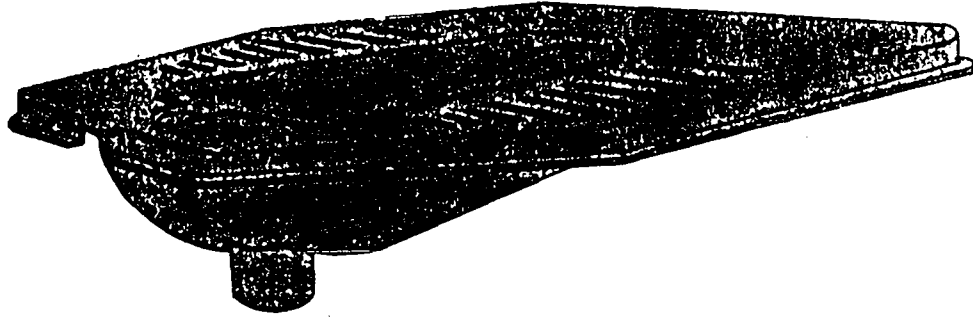

## المرحاض البلاستيك الجديد

- رخيص في ثمنه .
- سهل في تركيبه .
- سهل في تنظيفه .

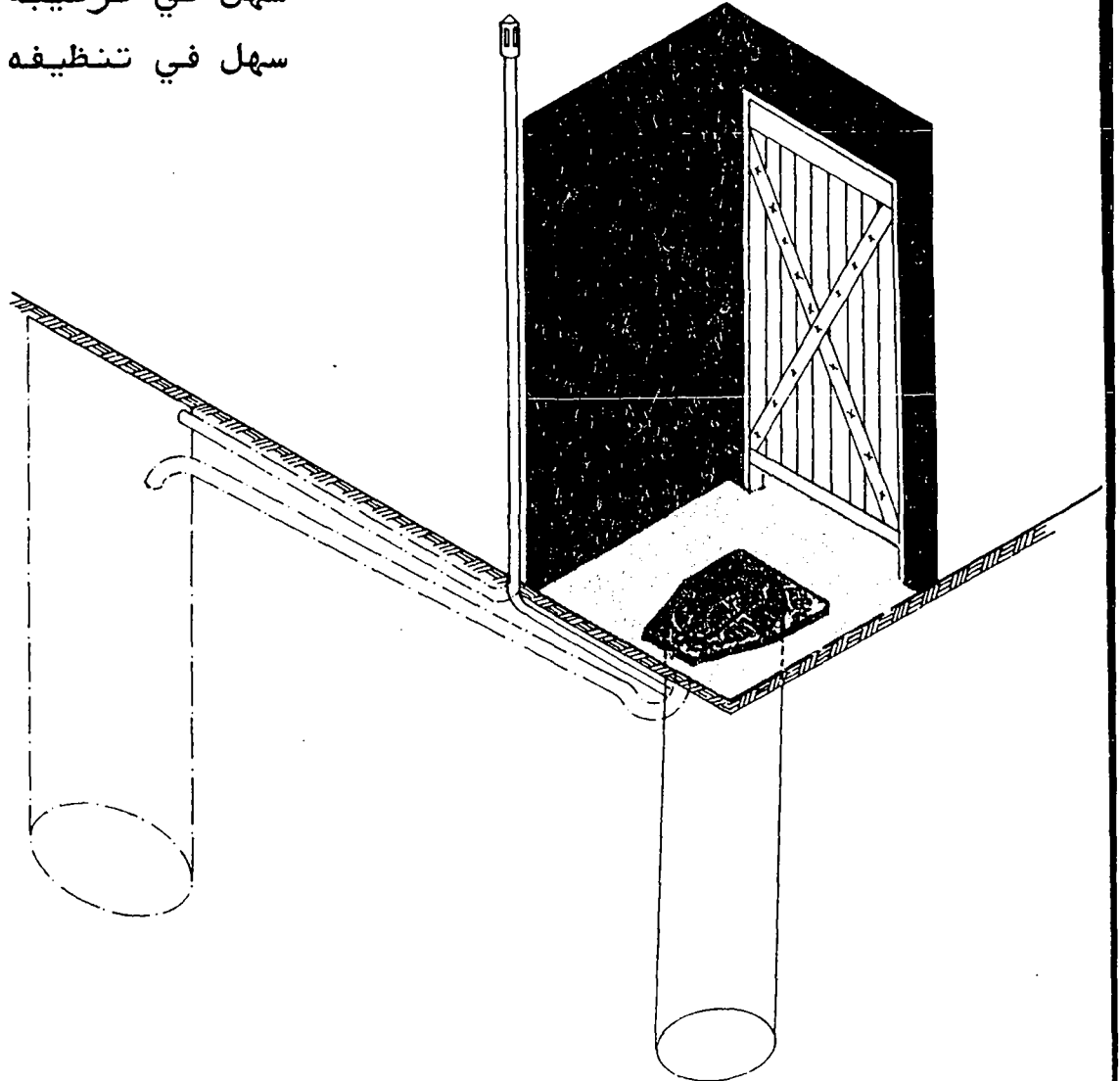

- (٣) يسهل تنظيفه بقليل من المياه حيث لا توجد صناديق طرد.
- (٤) يسهل نقله من مكان إلى آخر.
- (٥) يسهل وضعه فوق حفرة المراض أو بجوارها.
- (٦) يمكن تركيبه ونقله وإعادة تركيبه أكثر من مرة دون كسر أو تشوه.
- (٧) أرخص المراحيض بأنواعها فثمنه في متناول الجميع حيث لا يزيد عن عشرة جنيهات بينما ثمن مثيله من الخرسانة ضعف ذلك على الأقل.

## مشروع المرحاض البلاستيك

اعتاد معظم سكان الريف، ممن لا توجد لديهم مراحيض أن يقضوا حاجتهم في الخلاء، أو في الحظائر أو المجاري المائية المجاورة، أو في أوان من الفخار يتم إفراغ محتوياتها في المساء خارج الدار. وتسبب هذه العادة في انتشار كثير من الأمراض المتوطنة، فضلاً عن أنها عادة قبيحة ينبغي أن يترفع عنها الجميع، ولاسيما المرأة التي يجب أن تراعي أصول الاحتشام التي نصت عليها جميع الكتب المقدسة. وللتغلب على ما يقترن بهذه العادة من مشاكل صحية واجتماعية، ينبغي تزويد المنزل الريفي بمرحاض يستخدمه أفراد العائلة.

وعندما أدخلت المراحيض ضمن برامج الإصلاح في الريف، كانت تصنع من الخرسانة المسلحة السابقة التجهيز. وكان وزن المرحاض يصل إلى ١٢٥ كيلوغراماً، بحيث كان يصعب على شخص أو شخصين حمله. وكان هذا النوع من المراحيض سهل الكسر مما يستلزم الحرص في نقله، فضلاً عن صعوبة تركيبه وتنظيفه. كذلك كان يتخذ شكلاً مسطحاً بدون حاجز للمياه أو وعاء لمنع تصاعد الروائح الناتجة عن التحلل وانتشارها في غرفة المرحاض. وفضلاً عن هذا فقد بلغ ثمن هذا المرحاض ٢٠ جنيهاً، وهو مبلغ يتجاوز القدرة المالية للسكان الريفيين.

وكان من حسن الحظ أن ظهر في السوق المحلية مرحاض مصنوع من البلاستيك تجنب كل هذه المشاكل، وقد تم صنعه محلياً، وأثبت استعماله في المناطق الريفية والمجتمعات المنعزلة وغيرها نجاحاً ملموساً حيث يتميز بخفة وزنه الذي لا يتعدى الكيلوغرامين فقط، ونعومة ملمسه، ولونه المقبول، إضافة إلى رخص ثمنه الذي لا يتعدى العشرة جنيهاً، وهو سهل النقل والتركيب، والتنظيف حتى بدون طرد كما هو الحال في المنازل الريفية، وهو مزود بصندوق طرد. وهو يسمح بتركيب وعاء مائي حاجز للروائح، وذلك كله إضافة إلى إمكان استعماله وإعادة تركيبه لأكثر من مرة دون أي كسر أو تشوه وفي أكثر من مكان سواء كان مؤقتاً أو مستديماً وسواء كان البناء بسيطاً أو عادياً.

ولهذه المميزات كلها ينصح بإدخال هذا المرحاض البلاستيك المصنوع محلياً إلى المنازل الريفية المحرومة وذلك لمزاياه المذكورة والتي تسمح بتفوقه على غيره من المراحيض في هذه الأماكن إضافة إلى إمكان استعماله في المباني العامة في الريف كالمساجد والمدارس والمصالح الحكومية ودورات المياه العمومية وكذلك في أماكن الترفيه الموسمية وغيرها من الأماكن التي تقل فيها المياه، حيث يستلزم الأمر إقامة مرحاض متين خفيف الوزن وسهل التركيب والتنظيف والصيانة مع رخص ثمنه مما يسمح للجميع بالحصول عليه. وخلاصة القول فإن المرحاض البلاستيك، إضافة إلى أن استعماله يشجع على ممارسة العادات الصحية في قضاء الحاجة فإنه يتميز على غيره بالمميزات التالية:

(١) متين ويتحمل جميع الأوزان الادمية بأمان تام.

(٢) خفيف فوزنه كاملاً حوالي ٢ كيلوغرام بالمقارنة بالمرحاض المصنوع من الخرسانة والذي يصل وزنه إلى ١٢٥ كيلوغراماً.

وعليه، فإنه يوصى بإدخال المراحيض البلاستيكية المصنوعة محلياً في المناطق الريفية. كما يمكن استخدامها في المرافق العامة في الريف، مثل المساجد، والمدارس، ودورات المياه العمومية، والمكاتب الحكومية، وأماكن التنزه، وغير ذلك من الأماكن التي تتطلب تزويدها بمراحيض متينة، وخفيفة الوزن، وسهلة النقل والتركيب والتنظيف، لاسيما حيثما يكون الماء شحيحاً. ثم إن هذه المراحيض رخيصة وفي حدود القدرة الشرائية لجميع الناس. كما أن استخدام مرحاض جديد سوف يشجع مستخدميه على اتباع العادات الصحية. وتتمثل مزايا المرحاض البلاستيكي فيما يلي:

- (١) المتانة، إذ يتحمل من يستخدمونه مهما كانت أوزانهم.
- (٢) خفة الوزن، إذ يقل وزنه عن كيلوغرامين، بينما يزن المرحاض ذو البلاطة الخرسانية ١٣٥ كيلوغراماً.
- (٣) سهولة النقل.
- (٤) سهولة التركيب، سواء تم تركيبه فوق الحفرة مباشرةً أو بجوارها.
- (٥) إمكان تركيبه وفكه وإعادة تركيبه أكثر من مرة دون أن ينكسر أو يتشوه.
- (٦) سهولة التنظيف باستخدام قليل من الماء حيثما لا يوجد نظام للشطف بالماء.
- (٧) رخص التكلفة بالمقارنة بالأنواع الأخرى، إذ لا يزيد ثمنه على عشرة جنيهات، بينما لا يقل ثمن المرحاض ذي البلاطة الخرسانية عن ضعف ذلك المبلغ.

## خلاصة

مصر من أكبر بلدان الشرق الأوسط، إذ بلغ عدد سكانها ٥٥ مليون نسمة في عام ١٩٨٦. وحوالي ٣٠% من سكان الريف محرومون من خدمات المراحيض في منازلهم، المشيدة في الغالب من الطوب اللبن. ويعني ذلك أن ما يزيد على ثمانية ملايين مواطن من سكان الريف يضمهم نحو مليون ونصف مليون أسرة تقطن في حوالي مليون ونصف مليون منزل، في حاجة إلى مراحيض. إن قضاء الحاجة في الخلاء وبالقرب من الممرات المائية عادة مذمومة من الضروري أن ينبذها جميع الناس، لاسيما الفتيات والنساء؛ إذ ينبغي لمن التستر عند قضاء الحاجة، والالتزام بالعواد الصحية الحميدة في الوقت نفسه. وحتى يتسنى التغلب على هذه المشكلات الصحية والاجتماعية، ينبغي توفير مرحاض في كل منزل في الريف. وقد شهدت سنة ١٩٢٢ أول برنامج لتوفير المراحيض للسكان المحرومين منها في الريف. والمؤسف أن هذا المشروع لم يحالفه النجاح، نظراً لانعدام الوعي الاجتماعي والصحي لدى سكان الريف. ثم أعيدت التجربة خلال الأربعينيات والخمسينيات، وحالفها نجاح كبير. وقد كانت المراحيض التي تم توفيرها من خلال البرنامج هي أرخص ما في الأسواق في ذلك الوقت، ومصنوعة من الخرسانة المسلحة السابقة الصب، وثقيلة الوزن، وإن كانت هشة نسبياً. وكان من الضروري تناولها بحرص نظراً لما كان يكتنف تركيبها من صعوبة، وكان تنظيفها مثيراً للضجر. وقد كان المرحاض يتألف من بلاطة مسطحة من دون سلطانية ولا محبس يمنع تسرب الماء ويحول دون تصاعد رائحة الاختمار داخل مقصورة المرحاض. كما كان ثمن المرحاض يفوق القدرة الشرائية لسكان الريف الفقراء. على أنه من حسن الحظ أن ظهر في إقليم منظمة الصحة العالمية لجنوب شرقي آسيا مرحاض بلاستيكي صايف نجاحاً كبيراً عند استخدامه في مناطق مماثلة لأماكن استخدامه في مصر. وقد كان هذا المرحاض من البوليثيلين العالي الكثافة، لونه أبيض، خفيف الوزن، أملس، رخيصاً، سهل النقل والتركيب والتنظيف.

وقد تم استقصاء إمكانية صنع مرحاض بلاستيكي مماثل محلياً. كما أجريت دراسة عن السوق بين أصحاب المصانع، أظهرت جدوى صنع مرحاض مماثل بتكلفة منخفضة نسبياً لا تتجاوز نصف تكلفة المرحاض المعروف ذي البلاطة الخرسانية. ومن الممكن استخدامه إما على بلاطة خاصة فوق الحفرة مباشرة، وإما مجاوراً للحفرة على الأرضية وهذا هو الأفضل، لأنه يوفر تكلفة البلاطة.

وتقوم إحدى شركات البلاستيك في الإسكندرية بصنع مراحيض من البلاستيك يختلف تصميمها عن ذلك اختلافاً طفيفاً. ولهذه المراحيض جميع مزايا المراحيض المستوردة، بالإضافة إلى شكلها الشرقي التقليدي المألوف لدى المواطنين. وهي مصنوعة من البوليبروبيلين، وهو بلاستيك عادي أقل جودة من البوليثيلين العالي الكثافة، ورغم ذلك فإنها تمتاز بالمتانة، ويمكن صنعها من البوليثيلين العالي الكثافة بنفس التكلفة تقريباً. وقد طُرحت للبيع في السوق المحلية منذ بضع سنوات.

وبوجه عام، فقد ثبت أن المراحيض البلاستيكية، سواء المستورد منها أو المصنوع محلياً، تتمتع بالمزايا المطلوبة وهي: المتانة، وتحمل الأوزان الثقيلة، وخفة الوزن، إذ يقارب وزنها كيلوغرامين، بما في ذلك وزن المحبس المانع لتسرب الماء (بينما تزن البلاطة الخرسانية السابقة الصب ١٢٥ كيلوغراماً). كما أنها سهلة النقل والتركيب، ويمكن تنظيفها بسهولة من دون الشطف بالماء. كما أن الكوع المستخدم لمنع تسرب الماء من المرحاض يحول دون تصاعد الروائح منه. وللمرحاض شكل مقبول، ويمكن تركيبه وفككه لإعادة استخدامه مرة أخرى دون أن ينكسر أو يصيبه أي تشوه. كل ذلك بالإضافة إلى رخص تكلفته، التي تبلغ نصف تكلفة المراحيض الأخرى تقريباً.