

13383
1982

Appropriate Sanitation Alternatives A Planning and Design Manual

John M. Kalbermatten • DeAnne S. Julius • Charles G. Gunnerson • D. Duncan Mara

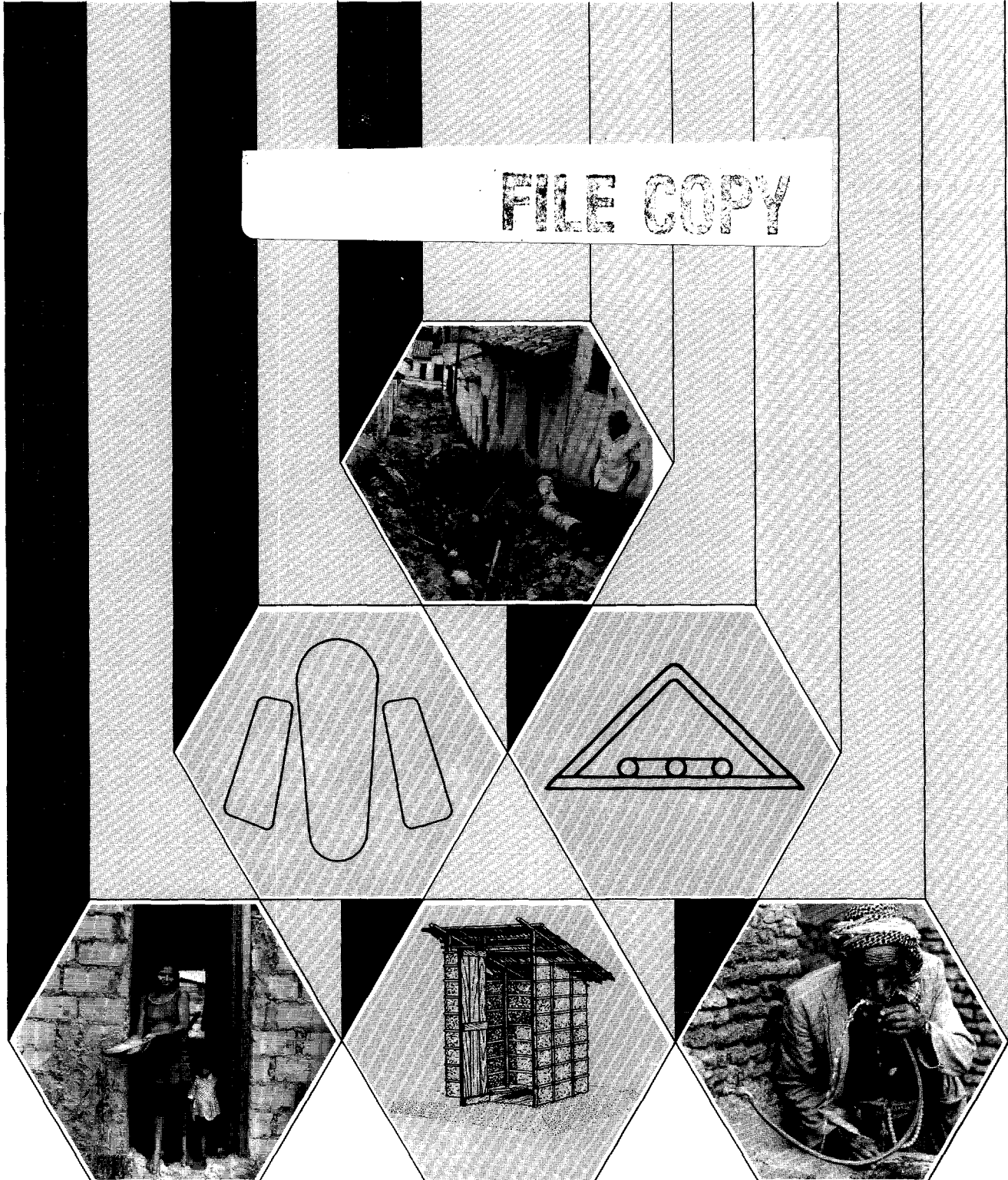

Appropriate Sanitation Alternatives
A Planning and Design Manual

WORLD BANK STUDIES IN
WATER SUPPLY AND SANITATION

2

Appropriate Sanitation Alternatives

A Planning and Design Manual

John M. Kalbermatten, DeAnne S. Julius,
Charles G. Gunnerson, and D. Duncan Mara

Published for The World Bank
The Johns Hopkins University Press
Baltimore and London

Copyright © 1982 by the International Bank for Reconstruction
and Development / THE WORLD BANK
1818 H Street, N.W., Washington, D.C. 20433, U.S.A.
All rights reserved
Manufactured in the United States of America

The Johns Hopkins University Press
Baltimore, Maryland 21218, U.S.A.

The views and interpretations in this book are the authors' and should
not be attributed to the World Bank, to its affiliated organizations, or
to any individual acting in their behalf.

EDITOR James McEuen
PRODUCTION Virginia deHaven Hitchcock
FIGURES Pensri Kimpitak
BOOK DESIGN Brian J. Svihart
COVER DESIGN George Parakamannil

Library of Congress Cataloging in Publication Data

Main entry under title:

Appropriate sanitation alternatives.

(World Bank studies in water supply and
sanitation; 2)

Bibliography: p.

Includes index.

1. Underdeveloped areas—Sanitary engineering.

I. Kalbermatten, John M. II. Series.

TD353.A64 1982 628.1'09172'4 82-13098

ISBN 0-8018-2584-9 (v. 2 : pbk.)

Contents

Foreword	ix	<i>Part Two. Sanitation Program Planning</i>	
Preface	xi	5. Comparison of Sanitation Technologies	39
Acronyms and Abbreviations	xiii	Water Supply Service Levels	39
1. An Overview	3	Soil Conditions	42
Dimensions of the Problem	3	Housing Density	42
The Constraints	4	Costs	43
Incremental Sanitation	4	Other Factors	44
Sanitation Program Planning	5	Environmental Factors Affecting Choice of Technology	45
<i>Part One. Socioeconomic Aspects of Sanitation Program Planning</i>		Institutional Constraints	45
2. Health Aspects of Sanitation	11	6. Selection of Sanitation Technologies	46
A Southeast Asian Family	11	Selection Algorithms	46
A North African Family	13	Postselection Questions	51
Excreted Infections	15	7. Sanitation Upgrading Sequences	52
Environmental Classification of Excreted Infections	17	Composting Toilets	52
Health Benefits of Sanitation Improvements	20	Three-Stage Septic Tanks	52
Excreted Infections and Children	21	Vault Toilets	52
Groundwater Pollution from On-site Excreta Disposal	21	VIP Latrines and ROEC's	55
3. Community Participation	23	PF Toilets	55
Characteristics of Community Participation	23	Sample Staged Solutions	55
Institution-Community Linkage	25	<i>Part Three. Sanitation Technology Options</i>	
4. Economic Analysis of Sanitation Technologies	27	8. Latrine and Toilet Superstructures	61
Economic Costing	27	9. Latrine and Toilet Fixtures	64
Financial Costing	31	Squatting Plates for VIP Latrines	64
Costing of Community Support Services	32	Squatting Plates for ROEC's	66
Appendix. Examples of Economic Costing	32	Pedestal Seats for VIP Latrines and ROEC's	66
		Squatting Plates for Composting, PF, and Vault Toilets	69
		Pedestal Seats for PF and Vault Toilets	72
		10. VIP Latrines	73
		VIDP Latrines	73
		ROEC's	77
		Pit Design	77
		Factors Affecting Suitability	81

11. Composting Toilets	83	Bibliography	153
Continuous Composting Toilets	83	Index	157
Batch Composting Toilets	83		
Vault Design	87		
Factors Affecting Suitability	88	Figures	
12. PF Toilets	89	1-1. Recommended Structure of Feasibility Studies for Sanitation Program Planning	6
PF Toilet Design	89	5-1. Generic Classification of Sanitation Systems	40
Factors Affecting Suitability	91	6-1. First-stage Algorithm for Selection of Sanitation Technology	47
Sewered PF Systems	91	6-2. Second-stage Algorithm for Selection of Sanitation Technology	48
13. Aquaprivies	94	6-3. Third-stage Algorithm for Selection of Sanitation Technology	49
Technical Appropriateness	94	7-1. Potential Sanitation Sequences	53
Self-topping or Sullage Aquaprivy	99	7-2. Sample Sanitation Sequences	54
Tank Design	99	8-1. Alternative Materials for Latrine Superstructures	62
Factors Affecting Suitability	100	9-1. Concrete Squatting Plate	65
14. Septic Tanks, Soakaways, and Drainfields	101	9-2. Tanzanian "Flap-trap" Design for VIP Latrines and DVC Toilets	66
Effluent Disposal	101	9-3. Pedestal Seats for Dry Latrines and Chute Designs for ROEC's	67
Technical Appropriateness	104	9-4. Water-seal Squatting Plate for PF Toilets Located Immediately above the Pit	68
Factors Affecting Suitability	107	9-5. Galvanized Sheet-metal Water-seal Unit for PF Toilets Located Immediately above the Pit	69
15. Conventional Sewerage	109	9-6. Plastic or Fiberglass Water-seal Toilet	70
Excreta Disposal	109	9-7. PF Units for Displaced Pits	71
Sewage Collection	109	10-1. Conventional Unimproved Pit Latrine	74
16. Small-bore Sewers	114	10-2. VIP Latrine	75
Technical Appropriateness	114	10-3. VIPD Latrine	76
Design Criteria	114	10-4. ROEC	78
17. Bucket Latrines	116	10-5. Alternative Pit Designs	80
18. Vault and Cartage Systems	118	11-1. "Multrum" Continuous-composting Toilet	84
Design Criteria	118	11-2. DVC Toilet Used in Vietnam	85
Factors Affecting Suitability	120	11-3. DVC Toilets	86
19. Communal Sanitation Facilities	122	12-1. Alternative Designs for PF Toilets	90
Effluent Disposal	122	12-2. PF Toilet-Septic-tank Systems	92
Design Criteria	122	13-1. Conventional Aquaprivy	95
20. Disposal and Treatment of Sullage	125	13-2. Formal Equivalence of Sullage Aquaprivy to VIP Latrine with Separate Sullage Soakaway or to PF Toilet	96
Sullage Volume and BOD	125	13-3. Formal Equivalence of Sewered Aquaprivy to Sewered PF Toilet	97
Health Aspects	126		
Design Criteria	126		
21. Off-site Treatment	128		
Waste Stabilization Ponds	128		
Night-Soil Treatment Ponds	133		
Thermophilic Composting	133		
Appendix. Examples of Waste Treatment Calculations	135		
22. Resource Recovery	145		
Agricultural Reuse	145		
Aquacultural Reuse	148		
Biogas Production	151		
Social, Institutional, and Economic Aspects of Reuse	151		

13-4. Improved Sewered Aquaprivy with Sullage Disposal	98
14-1. Schematic of Conventional Septic Tank	102
14-2. Alternative Septic Tank Designs	103
14-3. Schematic of Soakaway	104
14-4. Drainfield for Septic Tank Effluent	105
14-5. Evapotranspiration Mounds	106
15-1. Influence of Time and Temperature on Selected Pathogens in Night Soil and Sludge	112
17-1. Bucket Latrine and Cartage	117
18-1. Alternative Designs for Vault Toilets	119
19-1. Schematic of a Communal Sanitation Facility	123
20-1. Improved Stormwater Channels for Drainage of Sullage	127
21-1. Stabilization Pond Layout and Details	129
21-2. Inlet Structures for Stabilization Ponds	130
21-3. Alternative Interpond Connections	131
21-4. Outlet Structures for Stabilization Ponds	132
21-5. Beltsville Agricultural Research Center (BARC) System for High-rate Thermophilic Composting	134
21-6. Alternative Flow Diagrams for Composting Night Soil by BARC System	138
22-1. Reuse Potential of Wastes	146
22-2. Schematic of Typical Biogas Digesters	150

Tables

2-1. Viral, Bacterial, and Protozoan Pathogens Found in Excreta	12
2-2. Helminthic Pathogens Found in Feces	13
2-3. Environmental Classification of Excreted Infections	18
4-1. Annual Economic Costs of a Ventilated Improved Pit (VIP) Latrine	33
4-2. Shadow-priced Collection and Treatment Costs of a Conventional Sewerage Scheme Constructed over Five Years	33
4-3. Costs and Wastewater Flows for Conventional Sewerage Scheme	34
4-4. Present Values (pv) of Costs and Wastewater Flows for Conventional Sewerage Scheme	34
5-1. Descriptive Comparison of Sanitation Technologies	41
5-2. Summary of Annual Economic Costs per Household	43
6-1. Critical Information Needed for Selection and Design of Sanitation Systems	50
7-1. Costs of Sample Sanitation Sequences	56
14-1. Minimum Required Distances from Various Physical Features for Septic Tanks and Soakaways Located in Common Well-developed Soils	104
16-1. Slopes and Capacities of Circular Pipes Flowing Full	115
21-1. Equipment Needed for Night-Soil Composting	143

Foreword

DESPITE THE IMPRESSIVE LEVEL of economic growth the developing countries as a whole have achieved over the past quarter century, most of the people in these countries do not have a safe water supply or even rudimentary sanitation. Immediate investment costs for providing these services at the standards which prevail in developed countries are estimated at over \$800,000 million. Corresponding operating costs are projected at another \$10,000 million per year. These amounts vastly exceed the resources available for the sector. To help address this problem a two-year research project to develop more appropriate (i.e. lower cost) technologies for water supply and waste disposal was undertaken by the World Bank in 1976-1978. Meanwhile, the member countries of the United Nations have declared the 1980s to be the International Drinking Water Supply and Sanitation Decade, with the objective of satisfying for all populations of the globe two of the most basic human needs—clean water and the sanitary disposal of human wastes.

The Bank's research revealed the technological, economic, environmental, and institutional interdependence of water supply, sanitation, and health. Waste disposal technologies costing as little as one-tenth the amount of conventional sewerage were identified. Means to ensure high health and environmental benefits were developed. Emphasis was

also directed to the impact of water service levels upon waste disposal options and, where applicable, to opportunities for recovering some of the costs by physically recycling the water and fertilizer components of the waste.

This is the second of a series of volumes which document the Bank's research findings. Based on case studies in thirty-nine communities around the world, it presents to project engineers, analysts, and technicians a planning and design manual for the many sanitation options which are available and appropriate to developing country conditions. Other volumes in the series include a technical and economic assessment of these sanitation options to planning officials and senior policy advisors, and a compilation and synthesis of health and disease factors in sanitation system planning and implementation. Their publication is particularly timely at the beginning of this decade. More important, if the twin objectives of economic growth and the eradication of absolute poverty are to be met, the nations of the world must ensure that everyone has access to safe water and adequate sanitation. It is to the sanitation objective that this volume is dedicated.

WARREN C. BAUM
Vice President, Central Projects Staff
The World Bank

*Change the
part to abstr.
13384*

Preface

IN 1976 THE WORLD BANK undertook a research project on appropriate technology for water supply and waste disposal in developing countries. Emphasis was placed on sanitation and reclamation technologies, particularly on ways in which they are affected by water service levels and by the ability and willingness of the project beneficiaries to pay for them. In addition to the technical and economic factors, assessments were made of environmental, public health, institutional, and social constraints. The findings of the World Bank research project and other parallel research activities in the field of low-cost water supply and sanitation are presented in the series of publications entitled *World Bank Studies in Water Supply and Sanitation*, of which this is number 2. Other volumes in this series are:

Number 1. John M. Kalbermatten, DeAnne S. Julius, and Charles G. Gunnerson, *Appropriate Sanitation Alternatives: A Technical and Economic Appraisal*

Number 3. Richard G. Feachem, David J. Bradley, Hemda Garelick, and D. Duncan Mara, *Sanitation and Disease: Health Aspects of Excreta and Wastewater Management*

A series of related monographs entitled *Appropriate Technology for Water Supply and Sanitation* is available from the World Bank. Additional volumes and occasional papers will be published as ongoing research is completed.

It is the purpose of this manual to provide early dissemination of research results to field workers, to summarize selected portions of the other publications that are needed for sanitation program planning, and to describe engineering details of alternative sanitation technologies and the means by which the technologies can be upgraded. Although the design of water supply systems is not discussed at length, information on water service levels corresponding to

sanitation options is included because water use is a determinant of wastewater disposal requirements. The guidelines, procedures, and technologies contained in this volume are based upon World Bank studies in nineteen developing and industrial countries where local specialists conducted or contributed to the research. Both the research and its application continue to be undertaken by the Bank and others throughout the world. Future research will present improvements in resource recovery technologies, such as biogas; information on others, such as marine disposal of urban wastes, combined sewers, water-saving plumbing fixtures, and small-bore sewer design and operation; and more precise estimates of materials and construction requirements on both per capita and population-density bases.

This manual is intended both for professionally trained project engineers and scientists and for technicians and field workers who are familiar with the geographical and cultural conditions of the project areas to which they are assigned. The reason for emphasis on this familiarity is clear: it is upon the observations, interpretations, and communications of staff in the field that the ultimate success of sanitation programs depends; technical and economic analyses must incorporate recommendations from knowledgeable field specialists.

The findings and recommendations of this report are based on surveys of relevant literature (Rybczynski, Polprasert, and McGarry 1978; Kuhlthau 1980), an evaluation of sociocultural aspects (Elmendorf and Buckles 1980), detailed field studies (Kuhlthau 1980; Feachem, Mara, and Iwugo 1980; Elmendorf 1980; Lauria and others 1980), and the personal observations, experience, and advice of colleagues in the World Bank and other institutions. Because the list of contributors is so large, only a few can be mentioned. We wish to acknowledge in particular the support given to this project by Yves

Rovani, director of the Bank's Energy Department, and the valuable review and direction provided by the Bank staff serving on the steering committee for the project: Edward Jaycox, Arthur Bruestle, William Cosgrove, Frederick Hotes, Douglas Keare, Johannes Linn, Richard Middleton, Ragnar Overby, Alistair Stone, and Charles Weiss; Michael McGarry and Witold Rybczynski of the International Development Research Centre (Ottawa) were generous in their advice on specific issues. The contributions of consultants conducting field studies and providing specialized reports are acknowledged in the monographs to which they have contributed.

Special thanks are due to Richard Feachem and David Bradley of the Ross Institute of Tropical Hy-

giene (London), who have generously contributed help and advice and have allowed us to abstract and quote some of their own publications.

The reports could not have been produced without the dedication and cooperation of the secretarial staff, Margaret Koilpillai, Julia Ben Ezra, and Susan Purcell, and the editorial assistance of research assistant David Dalmat. Their work is gratefully acknowledged.

JOHN M. KALBERMATTEN
DEANNE S. JULIUS
CHARLES G. GUNNERSON
D. DUNCAN MARA

Acronyms and Abbreviations

AIC	Average incremental cost	PF	Pour-flush (toilet)
BARC	Beltsville Agricultural Research Center (U.S. Department of Agriculture, Beltsville, Maryland, U.S.A.)	PV	Present value
BOD	Biochemical oxygen demand	PVC	Polyvinyl chloride
BOD ₅	Five-day BOD (by the standard test)	ROEC	Reed Odorless Earth Closet
CRF	Capital (or annuity) recovery factor	UNC	Units of national currency
DVC	Double-vault composting (toilet)	VIDP	Ventilated improved double-pit (latrine)
		VIP	Ventilated improved pit (latrine)

Appropriate Sanitation Alternatives
A Planning and Design Manual

1

An Overview

A READILY AVAILABLE SUPPLY of safe water and the sanitary disposal of human wastes are essential, although not the only, ingredients of a healthy, productive life.¹ Water that is not safe for human consumption can spread disease; water that is not readily accessible takes up the productive time and energy of the water carrier—usually women or children; inadequate facilities for excreta disposal reduce the potential benefits of a safe water supply by transmitting pathogens from infected to healthy persons. Over fifty infections can be transferred from a diseased person to a healthy one by various direct or indirect routes involving excreta. Coupled with malnutrition, these excreta-related diseases take a dreadful toll in developing countries, especially among children. For example, in one Middle Eastern country, half of the children born alive die before reaching the age of five as a result of the combined effects of disease and malnutrition; in contrast, only 2 percent of children born in the United Kingdom die before reaching their fifth birthday.

Invariably it is the poor who suffer the most from the absence of safe water and sanitation, because they lack not only the means to provide for such facilities but also information on how to minimize the ill effects of the unsanitary conditions in which they live. As a result, the debilitating effects of unhygienic living conditions lower the productive potential of the very people who can least afford it.

Dimensions of the Problem

To understand the magnitude of the problem, it is only necessary to consider data collected by the World Health Organization in preparation for the United Nations Water Conference that took place in Mar del Plata, Argentina, in the spring of 1977. These figures show that only 32 percent of the pop-

ulation in developing countries have adequate sanitation services; that is, about 630 million out of 1.7 billion people.² Population growth over the span of the International Drinking Water Supply and Sanitation Decade (1981–90) will add another 700 million people who will have to be provided with some means of sanitation if the goals of the Decade—adequate water supply and sanitation for all people—are to be achieved. A similar number of people, about 2 billion, will require water supply by the same date. Thus, roughly half the world's present total population of just over 4 billion people have to be provided with water and sanitation services to meet the Decade's targets; that is, approximately half a million people per day for the next twelve years.

One of the fundamental problems in any attempt to provide the necessary sanitation services is their cost. General estimates based on existing per capita costs indicate that around \$800 billion would be required to provide water supply and conventional sewerage for everyone.³ Per capita investment costs for sewerage range from \$150 to \$650, which is totally beyond the ability of the intended beneficiaries to pay: some 1 billion of these unserved people have per capita incomes of less than \$200 per year; more than half have incomes below \$100 per year.

In industrialized countries, the standard solution for the sanitary disposal of human excreta is water-borne sewerage. Users and responsible agencies have come to view the flush toilet as the absolutely essential part of an adequate solution to the problem of excreta disposal. This method, however, was designed to maximize user convenience rather than health benefits, an objective that may be important in developed countries but has a lower priority in developing countries. In fact, conventional sewerage is the result of slow development over decades, even centuries, from the pit latrine to the flush toilet, and the present standard of convenience has been achieved at substantial economic and environmental costs.

The problem facing developing countries is a familiar one: high expectations coupled with limited resources. Decisionmakers in these countries are asked to achieve the standards of convenience observed in the industrialized world. Given the backlog in service, the massive size of sewerage investments, and the demands on financial resources by other sectors, they do not have the funds to realize this goal. Sewerage could be provided for a few, but at the expense of the vast majority of the population. As a consequence, many developing countries have taken no steps at all toward improving sanitation. The very magnitude of the task has effectively discouraged action.

At the present time the first priority of excreta disposal programs in developing countries should be the improvement of human health; that is, the accomplishment of a significant reduction in the transmission of excreta-related diseases. This health objective can be fully achieved by sanitation technologies that are much less costly than sewerage. The goals for the Decade of the 1980s intentionally do not specify sewerage, but call for the sanitary disposal of excreta, leaving the disposal method to the discretion of individual governments. Similarly, Decade targets include an adequate supply of safe water, without specifying the methods to be used to achieve the goal. To provide as many people as possible with safe water and sanitation is to find technologies which can achieve these objectives with the resources available.

The Constraints

The primary constraints to the successful provision of sanitation facilities in developing countries are the lack of funds, the lack of trained personnel, and the lack of knowledge about acceptable alternative technologies. Where high-cost systems developed in industrialized countries have been used to solve waste disposal problems in developing countries, access to the facilities has been limited to the higher income groups, who are the only ones able to afford them. Little official attention has been paid to the use of low-cost sanitation facilities to provide health benefits to the majority of the population. This situation exists because officials and engineers in developing and developed countries alike are neither trained nor experienced in the consideration or design of alternative sanitation systems or in the evaluation of the effects of these alternatives on health. Waterborne sewerage is designed to satisfy convenience and local environmental, rather than health, require-

ments. The lesson commonly (but erroneously) drawn from the historical development of sanitation technology is that the many less costly alternatives formerly used should be abandoned rather than improved. Therefore, few serious attempts have been made to design and implement satisfactory low-cost sanitation technologies. The implementation of such alternatives is complicated by the need to provide for community participation in both the design and operating stages of the projects. Few engineers are aware of the need to consider the sociocultural aspects of excreta disposal, and fewer still are competent to work with a community to determine the technology most compatible with its specific needs and resources.

Given these constraints, it is not surprising that sanitation service levels in developing countries have remained low. A major effort is needed to identify and develop alternative sanitation technologies appropriate to local conditions in developing countries and designed to improve health rather than raise standards of user convenience. Clearly the solutions must be affordable to the user and reflect community preferences if they are to find acceptance.

Incremental Sanitation

An examination of how conventional waterborne sewerage came about reveals three facts very clearly. First, excreta disposal went through many stages before sewerage. Second, existing systems were improved and new solutions devised whenever the old solution was no longer satisfactory. Third, improvements were implemented over a long period of time as funds became available to meet conditions of crowding and demands for convenience. Sewerage was not a grand design implemented in one giant step, but the end result of a long series of progressively more technologically sophisticated solutions. For example, the collection of night soil from bucket latrines in eighteenth century London was a step toward reducing gross urban pollution. This was followed by piped water supplies and the development of combined sewerage, then separate sanitary sewerage, and eventually sewage treatment prior to river discharge. This particular series of improvements spanned over 100 years—a time frame necessitated by historical constraints in science, technology, and capital. Present levels of knowledge enable sanitation planners to select from a wider range of options and to design a sequence of incremental sanitation improvements. The choice of proceeding with sequential improvements is the user's, who also decides

the time frame over which improvements are to be made and higher levels of convenience achieved in step with his increasing income. Most important, a user can start with a basic low-cost facility without the need to wait for greater income, knowing that he will have a choice to provide for greater convenience when he has the funds and wishes to do so at some future date.

Sanitation Program Planning

Sanitation program planning is the process by which the most appropriate sanitation technology for a given community is identified, designed, and implemented. The most appropriate technology is defined as the one that provides the most socially and environmentally acceptable level of service at the least economic cost.

The process of selecting the appropriate technology begins with an examination of all of the alternatives available for improving sanitation; these are described in Part Two of this book. There will usually be some technologies that can be readily excluded for technical or social reasons. For example, septic tanks with large drainfields would be technically inappropriate for a site with a high population density or with bedrock near the ground surface. Similarly, a composting latrine would be socially inappropriate for people who have strong cultural objections to the sight or handling of excreta. Once these exclusions have been made, cost estimates are prepared for the remaining technologies. These estimates should reflect real resource cost to the economy, and, as described in chapter 4, this may involve making adjustments in market prices to counteract economic distortions or to reflect development goals such as employment creation. Since the benefits of various sanitation technologies cannot be quantified, the health specialist must identify those environmental factors in the community that act as disease vehicles and recommend improvements that can help prevent disease transmission. The final step in identifying the most appropriate sanitation technology rests with the intended beneficiaries. Those alternatives that have survived technical, social, economic, and health tests are presented to the community with their attached financial price tags, and the users themselves decide what they are willing to pay for. An algorithm for technology selection that incorporates economic, social, health, and technical criteria is presented in chapter 6.

Figure 1-1 shows how the various checks are actually coordinated in practice. The checks them-

selves, of course, are interrelated. A technology may fail technically if the users' social preferences militate against its proper maintenance. The economic cost of a system is heavily dependent upon social factors, such as labor productivity, as well as on technical parameters. Because it is operationally difficult to use simultaneous (or even iterative) decision processes, a step-by-step approach with feedback across disciplines is suggested.

For simplicity it is assumed that separate individuals or groups are responsible for each part, although in practice responsibilities may overlap. In stage 1 each specialist collects the information necessary to make his respective exclusion tests. For the engineer, public health specialist, and behavioral scientist⁴ this data collection would usually take place in the community to be served. The economist would talk with both government and municipal officials to obtain the information necessary to calculate shadow rates and to obtain information on the financial resources likely to be available. The behavioral scientist would consult with and survey the potential user and community groups. Then, in stage 2, the engineer and sociologist apply the information they have collected to arrive at preliminary lists of technically and socially feasible alternatives. The public health specialist relates the most important health problems to any relevant environmental factors involving water, excreta, or both. In the third stage the economist prepares economic cost estimates for those technologies that have passed the technical and social tests and selects the least-cost alternative for each technology option. At the fourth stage the engineer prepares final designs for these remaining choices. The social information collected in stage 1 should be used in this process to determine the siting of the latrine on the plot, the size of the superstructure, the materials to be used for the seat or slab, and other details that may have low technical and economic importance but make a major difference in the way the technology is accepted and used in the community. The designs should also incorporate features necessary to maximize the health benefits from each technology. Final designs are turned over to the economist in the fifth stage so that financial costs can be determined, including how much the user would be asked to pay for construction and maintenance of each alternative. In the last stage the behavioral scientist presents and explains the alternatives, their financial costs, and their future upgrading possibilities to the community for final selection. The form that this community participation takes will vary greatly from country to country; its important elements are discussed in chapter 3.

Figure 1-1. Recommended Structure of Feasibility Studies for Sanitation Program Planning

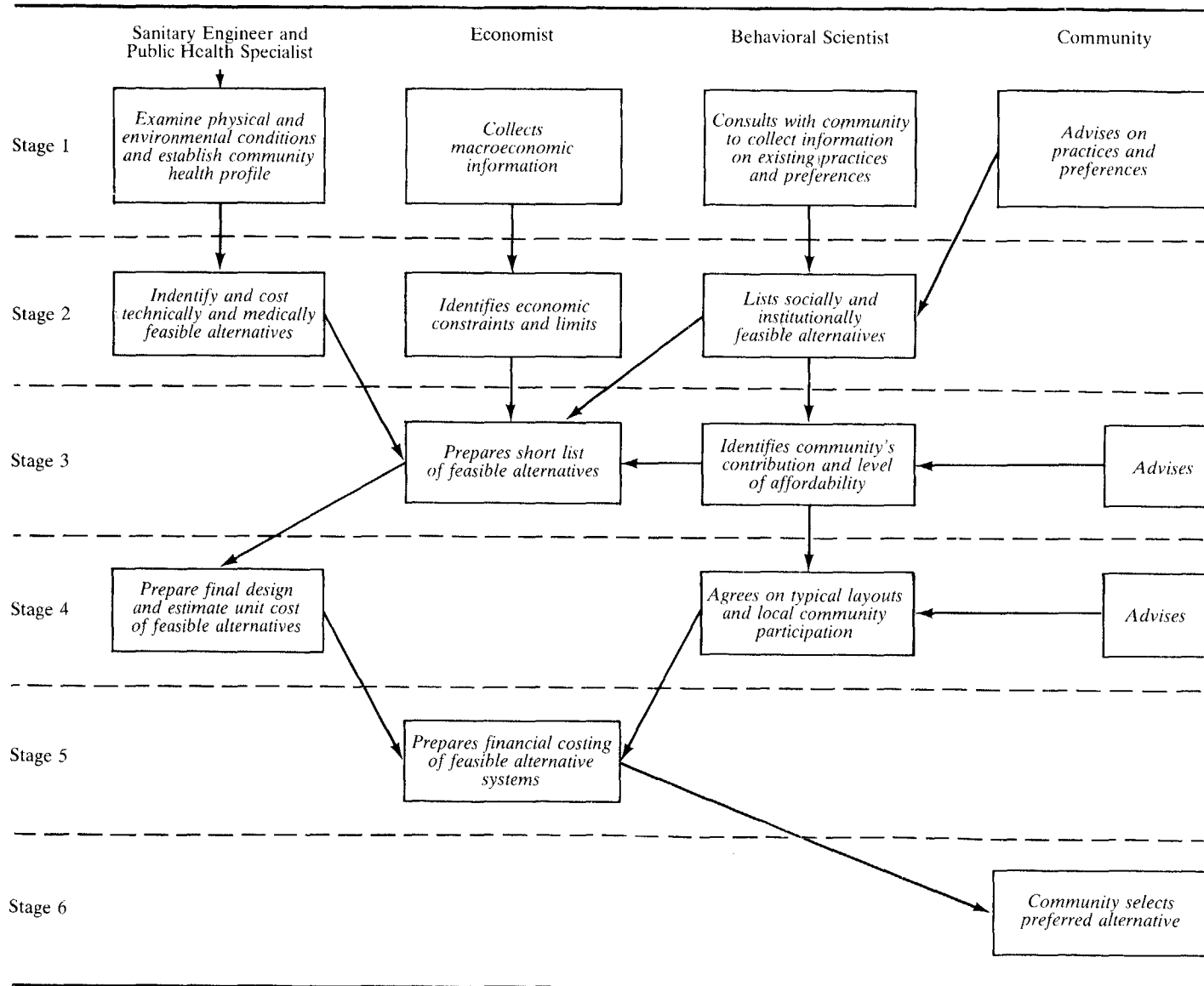

As part of the sanitation planning process, the existing or likely future pattern of domestic water use should be ascertained so that the most appropriate method of sullage disposal can be selected. This is particularly important in the case of properties with a multiple tap level of water supply service, since large wastewater flows may, according to conventional wisdom, preclude the consideration of technologies other than sewerage or, in low-density areas, septic tanks with soakaways. It is not necessary, however, either for reasons of health or user convenience, for domestic water consumption to exceed 100 liters per capita daily.⁵ The use of low-volume cistern-flush toilets and various simple and inexpensive devices for reducing the rate of water flow from taps and showerheads (described in the appendix of chapter 4) can achieve substantial savings in water consumption without any decrease in user convenience or any required change in personal washing habits. These savings can be as high as 75 percent in high-water-pressure areas and 30 to 50 percent in low-pressure areas. If wastewater flows can be reduced by these means, then the options for sanitation facilities are much broader than only conventional sewerage. In addition, separation of toilet wastes from other wastewater by simple modifications in household plumbing, coupled with improved designs of septic tank filters (see chapter 14), may make nonsewered options more widely feasible.

The framework suggested in this chapter for the identification of the most appropriate sanitation technology takes more engineering time and analysis than that of traditional feasibility analysis. It also requires the recruitment of staff in other disciplines, such as behavioral scientists. In addition, the concept of incremental sanitation requires municipal activity in sanitation programs to be spread over a considerably longer time because the user has the option

of whether and when to proceed to the next higher level of convenience. Yet we believe that the planning format discussed above has a far greater chance of achieving operational success because the most appropriate sanitation technology is drawn from a wider range of alternatives, imposes the least cost burden on the economy, maximizes the health benefits obtainable, and is selected after extensive interaction with the intended beneficiaries. Because incremental sanitation systems are so much less expensive than sewerage (both in initial investment and total discounted cost), many more people can be provided with satisfactory excreta disposal facilities for the same amount of money, and these facilities can be upgraded as more money becomes available in the future. Given the huge service backlog and the severe investment capital constraints in developing countries, incremental sanitation may be the only, as well as the best, way to meet the sanitation goals of the International Drinking Water Supply and Sanitation Decade.

Notes to Chapter 1

1. For a more detailed discussion of the issues in this chapter, see chapters 1 and 2 of Kalbermatten, Julius, and Gunnerson (1982).
2. One billion is equivalent to one thousand million.
3. All dollar figures in this manual are 1978 U.S. dollars.
4. The term "behavioral scientist" is used to describe a person skilled in assessing community needs, preferences, and processes. The person's training may be in anthropology, communications, geography, sociology, or psychology, or it may come from a wide variety of education and experience.
5. Where water has to be carried, 20 liters per capita daily is considered a *minimum acceptable level to provide all the health benefits of a safe water supply*. With closer standpipe spacing and yard hydrants, consumption rises typically to 50 and, with house connections, to 100 liters per capita daily. At the higher levels of consumption, off-site disposal of sullage becomes necessary.

Part One

*Socioeconomic Aspects
of Sanitation Program Planning*

2

Health Aspects of Sanitation

IMPROVED HEALTH is normally considered one of the principal benefits of improved sanitation.¹ Excreta contain a wide variety of human pathogens (tables 2-1 and 2-2), and the removal of these pathogens from the immediate environment, which is achieved by proper sanitation, can have a dramatic effect on community health. Prior or concurrent improvements in water supply and solid waste collection services and a vigorous and sustained campaign of community education in hygiene are ordinarily required, however, before all the health benefits of a sanitation improvement program can be realized.

In this chapter a recently developed environmental classification of excreta-related infections is presented, and the likely health benefits of sanitation improvements are discussed. Particular emphasis is placed on the effects on children, who are in many ways the most vulnerable to excreta-related infections. First, however, two illustrative sketches that describe the effects of poor sanitation on two families living in different parts of the world are presented to help the reader visualize the poor health and sanitation status of the urban and rural poor throughout the world.

A Southeast Asian Family

In high-rainfall areas of Southeast Asia with a perennially hot climate and where irrigated rice is the main cereal crop, the health hazards from excreta are diverse. They may be illustrated by the following case history, which is a composite of several real sites and people. A family lives in a palm-roofed, wooden house surrounded by rice fields and small irrigation channels, one of which, flowing near the house, acts as the domestic water supply. There are four children in the family; the mother has had six babies but one died following a sudden attack of diarrhea at the age of fifteen months, and a child of school age died in

the cholera epidemic that swept through the area four years ago.

It is particularly difficult to control excreta in this damp environment; most feces are deposited not far from the house, and the younger children urinate in the canals nearby. Some years ago a government campaign was mounted to provide pit latrines, and one was dug near the family's house. They used it for a while, but in the monsoon season the pit flooded and a large quantity of fecal material was spread around the house. It was around that time that the cholera epidemic occurred, and its sad consequences for the family, together with the unpleasant mess, discouraged them from using the pit latrine again. The next government recommendation was to build a concrete aquaprivy extending well above the ground to avoid the flood problem, but the family could not afford this and went back to defecating around the home during the day. Nocturnal excreta were collected in a bucket and deposited in a nearby fishpond.

How has this situation affected the family's health? All the children get diarrhea several times a year, as do the parents from time to time. The worst occasion was when two girls, both under three years of age, got it at the same time. The younger one seemed just to shrivel up overnight, and she died the next day. Her death may have been attributable to rotavirus infection, but the reason that this infection should more often be lethal in the tropics than it is in temperate countries is unclear. Certainly the poor sanitary facilities were a factor, particularly in combination with the malnutrition that is so ubiquitous during the weaning period in communities such as this one. Most of the diarrheas are sudden attacks that produce watery stools, but last year the grandmother, who shares the house with the family, was one of several people in the village who suffered an attack of a more painful diarrhea, which produced blood in the feces and from which she nearly died.

Table 2-1. *Viral, Bacterial, and Protozoan Pathogens Found in Excreta*

<i>Biological group and organism</i>	<i>Disease^a</i>	<i>Reservoir</i>
Viruses		
Coxsackievirus	Various	Man
Echovirus	Various	Man
Hepatitis A virus	Infectious hepatitis	Man
Poliovirus	Poliomyelitis	Man
Rotavirus	Gastroenteritis in children	?
Bacteria		
<i>Campylobacter</i> species	Diarrhea in children	Animals and man
Pathogenic <i>Escherichia coli</i>	Gastroenteritis	Man
<i>Salmonella typhi</i>	Typhoid fever	Man
<i>S. paratyphi</i>	Paratyphoid fever	Man
Other salmonellae	Food poisoning	Man and animals
<i>Shigella</i> species	Bacillary dysentery	Man
<i>Vibrio cholerae</i>	Cholera	Man
Other vibrios	Diarrhea	Man
<i>Yersinia</i> species	Yersiniosis	Animals and man
Protozoa		
<i>Balantidium coli</i>	Mild diarrhea	Man and animals
<i>Entamoeba histolytica</i>	Amebic dysentery and liver abscess	Man
<i>Giardia lamblia</i>	Diarrhea and malabsorption	Man

Source: Feachem and others (forthcoming).

a. In all diseases listed, a symptomless carrier state exists.

Medicine from the dispensary 6.5 kilometers away seemed to help her begin to recover, but even so she remained ill for weeks. The attack was from bacillary dysentery, though it would have been difficult without laboratory tests to be sure it was not from amebiasis.

All these were dramatic illnesses, but the family has several more insidious health problems of which they are barely aware. The eldest son has not grown properly; although he is twenty-three, he looks as if he were in his early teens. His belly is always grossly swollen, and the dispensary attendant can feel his hard liver and spleen under the tight skin. These physical effects are from schistosomiasis, which is spread from one person to another through a tiny snail living in the damp grass beside the canals as well as in the water itself. Several of the family are infected, but only this boy has obvious symptoms, although the father suffers from elephantiasis, a non-intestinal infection described below.

With so much water around, fish is an acceptable and available food item, sometimes cooked but often pickled in vinegar. A proportion of these fish are grown in ponds that are fertilized with human feces, and this practice has caused some of the family to become infected with the helminth (parasitic worm) *Clonorchis sinensis*. Another helminth that the fam-

ily has in large numbers is *Fasciolopsis buski*, acquired from eating aquatic vegetables in an uncooked state. Neither of these parasites has catastrophic results, but their diversion of food from their human hosts and their other insidious effects make life less satisfactory than it otherwise might be. The family also suffers from many other intestinal worms occurring in even greater numbers and causing more illness. (These are discussed below in relation to another family.)

A nonintestinal infection is also associated with the family's problems of excreta disposal. Within the pit latrines that have been flooded and abandoned, the fecal liquid is colonized by larvae of a mosquito known as *Culex pipiens*.² When the adult females of this mosquito bite the members of the household, they are able to transmit the larvae of a parasitic worm that then inhabits the tissues under the skin of the legs and elsewhere. In particular, these worms inhabit the lymph nodes and block the flow of lymph, causing a disease known as bancroftian filariasis or elephantiasis. As a consequence, the tissues become swollen from the accumulation of lymph, and in some of the people a massive elephantiasis results. The father is troubled by this in his right leg, which is so swollen that he cannot work in the fields as well as he could before.

Table 2-2. *Helminthic Pathogens Found in Feces*

Pathogen	Common name	Disease	Transmission	Distribution
<i>Ancylostoma duodenale</i>	Hookworm	Hookworm infection	Man→soil→man	Mainly in warm wet climates
<i>Ascaris lumbricoides</i>	Roundworm	Ascariasis	Man→soil→man	Worldwide
<i>Clonorchis sinensis</i>	Chinese liver fluke	Clonorchiasis	Animal or man→aquatic snail→fish→man	Southeast Asia
<i>Diphyllobothrium latum</i>	Fish tapeworm	Diphyllobothriasis	Man or animal→copepod→fish→man	Widely distributed foci, mainly temperate regions
<i>Enterobius vermicularis</i>	Pinworm	Enterobiasis	Man→man	Worldwide
<i>Fasciola hepatica</i>	Sheep liver fluke	Fascioliasis	Sheep→aquatic snail→aquatic vegetation→man	Worldwide in sheep- and cattle-raising areas
<i>Fasciolopsis buski</i>	Giant intestinal fluke	Fasciolopsiasis	Man or pig→aquatic snail→aquatic vegetation→man	Southeast Asia, mainly China
<i>Gastrodiscoides hominis</i>	—	Gastrodiscoidiasis	Pig→aquatic snail→aquatic vegetation→man	India, Bangladesh, Vietnam, Philippines
<i>Heterophyes heterophyes</i>	—	Heterophyiasis	Dog or cat→brackish-water snail→brackish-water fish→man	Middle East, southern Europe, Asia
<i>Hymenolepis</i> species	Dwarf tapeworm	Hymenolepiasis	Man or rodent→man	Worldwide
<i>Metagonimus yokogawai</i>	—	Metagonimiasis	Dog or cat→aquatic snail→freshwater fish→man	Japan, Korea, China, island of Taiwan, Siberia (U.S.S.R.)
<i>Necator americanus</i>	Hookworm	Hookworm infection	Man→soil→man	Mainly in warm wet climates
<i>Opisthorchis felineus</i> <i>O. viverrini</i>	Cat liver fluke	Opisthorchiasis	Animal→aquatic snail→fish→man	U.S.S.R., Thailand
<i>Paragonimus westermani</i>	Lung fluke	Paragonimiasis	Pig, man, dog, cat, or other animal→aquatic snail→crab or crayfish→man	Southeast Asia, scattered foci in Africa and South America
<i>Schistosoma haematobium</i> <i>S. japonicum</i>	Schistosome; bilharzia	Schistosomiasis; bilharziasis	Man→aquatic snail→man	Africa, Middle East, India
<i>S. mansoni</i>	—	—	Animals and man→snail→man Man→aquatic snail→man	Southeast Asia Africa, Arab Middle East, Central and South America
<i>Strongyloides stercoralis</i>	Threadworm	Strongyloidiasis	Man→man (?) (dog→man)	Mainly in warm wet climates
<i>Taenia saginata</i> <i>T. solium</i>	Beef tapeworm Pork tapeworm	Taeniasis Taeniasis	Man→cow→man Man→pig→man, or man→man	Worldwide Worldwide
<i>Trichuris trichiura</i>	Whipworm	Trichuriasis	Man→soil→man	Worldwide

— Not applicable.

Source: Feachem and others (forthcoming).

A North African Family

The North African village is quite different in general appearance, but behind this difference there are certain similarities in disease problems. The village is a cluster of mud-brick houses situated in the sub-

tropics. In the winter it is quite cold, though the summer temperatures are at least as high as in the Asian village just described. The houses cluster together on a mound rising up from the irrigated areas around. This irrigation, however, is by water brought from afar by great rivers, not by heavy rainfall. The ground is baked hard where it has not recently been irrigated. Within the village the streets are narrow;

they are not made up or paved, and large quantities of debris lie around.

One family in this village consists of parents with three children and some elderly relatives. There is again the sad story of some children dying from diarrheal disease; in tropical areas diarrheal disease (alone or in combination with other diseases) is almost invariably the principal cause of child mortality. There are some exceptions in areas where the very high incidence of malaria makes this the greater threat, but in these areas the overall death rate is even higher.

As in Asia, we find problems of schistosomiasis and of elephantiasis. These are of a somewhat different type from the Asian forms but nevertheless create disability in similar ways. In addition to intestinal schistosomiasis, two of the younger children have a urinary variety and are passing blood in their urine every day. This looks more serious than it is; in fact, the blood loss is not great. Nevertheless, the children suffer pain and the inconvenience of having to get up frequently to pass urine at night.

The helminths associated with fish and water plants that troubled the previous family are absent from this one, but when we look at the family's feces under the microscope we find the eggs of *Ancylostoma duodenale* (hookworm), *Ascaris lumbricoides* (roundworm), and *Trichuris trichiura* (whipworm) in large numbers. The hookworm eggs are particularly numerous. Infection has been contracted by the family's wandering about with bare feet on land that has been used for defecation and has been kept moist enough by nearby drains and canals for the larval worms to develop in the soil. The worms live in the small intestine and attach themselves to the inside walls of the intestinal tract. They suck blood, which is used for their growth and for the production of their eggs, but they are very messy feeders and large amounts of blood pass straight through their bodies and are lost into the intestine. As a result the blood losses from this infection are very heavy. The hookworms are particularly numerous in the mother of the family, and her blood loss is twice as heavy as that from menstruation. Since her diet is not particularly rich in iron, she has consequently become very anemic and is unable to work nearly as much as a fit person. The same applies to one of the children of the family: his abdomen is swollen, he cannot run fast to keep up with the other children, and his condition gives the family considerable cause for anxiety. If he were to catch some other infection in addition to hookworm, he might well lose his life.

All the family have roundworms. These are very large (over 100 millimeters long), and every now and

then one of the younger children passes one in his stools. This excites a little comment, but there is not obvious illness except for pain in the abdomen; as always, it is difficult to ascribe this to a particular cause. What is certain is that the worms are absorbing a good deal of the nutrients intended for the children, and there is also a risk that the worms will get stuck in the narrowest part of the intestine and block it, a condition requiring a surgeon's attention. The family is well aware of this problem and has visited the dispensary to get medicine on frequent occasions. Unfortunately, in the absence of better methods of disposing of excreta, the infection comes back every few months. The adults seem to have become somewhat immune to the infection, and the children carry the brunt of the disease.

What arrangements are made for excreta disposal here? A bore-hole latrine was made for each family to use, but it filled up quickly and was so unpleasant that no one wanted to use it. In any case, it was near the house, and the family spends much of the day in the fields working on rice and other crops. It would be a quite unreasonable waste of their time, or so they feel, to come all the way back to the home merely to defecate. It is also more convenient to defecate in the field because the family's religion insists that they wash the anus after defecation, and there is no water readily available for this purpose within the compound. Because of these varying sites for defecation, eggs of *Ascaris* and *Trichuris* are spread rather widely throughout the environment. They are extremely resistant, even to the harsh climate of this part of the world, and find their way onto vegetables, which are eaten raw. They also occur in the mud and sand of the compound, from which they are readily picked up by the hands of crawling babies.

Another intestinal worm of some importance is the beef tapeworm (*Taenia saginata*). This is acquired by eating undercooked beef, which can occur when meat is roasted in a large piece. The adult tapeworm matures in the intestines of the family, and it too competes for nutrients with its hosts. Its eggs, often in the swollen segments of the tapeworm, are shed in large numbers when a whole segment of tapeworm wriggles out of the anus. These tapeworm segments may be ingested by browsing cattle and undergo further development within the muscles of the cow. The family's religion prohibits the eating of pork, and so they are spared infection by pork tapeworm (*Taenia solium*), which has as one of its possible hazards the larvae's developing in human muscles.

All these helminthic infections are long lasting and sap the strength, so that it is not easy to attribute

specific damage to their presence, except in the case of hookworm. They are all infections that tend to be underrated because of their widespread nature and insidious, drawn-out course. By contrast, the family also suffers from several acute infections—not only diarrheas, which have been discussed already, but also typhoid and hepatitis. The incidence of typhoid in the village is very high. This is for several reasons, not least of which are the defective arrangements for excreta disposal. In addition, the complication of schistosomiasis in the inhabitants leads to a very drawn-out course of the typhoid, and up to one in every twenty-five people may become a typhoid carrier in some of these villages. This incidence is an order of magnitude or more higher than is found elsewhere. The upshot is that typhoid is extremely common, no less severe than elsewhere, and an appreciable cause of mortality. Hepatitis, too, occurs frequently. In the younger children it rarely gives rise to serious symptoms, but in adults the patient may have to take to his bed for weeks or months, and acute illness leading to death is not unknown.

One feature that emerges with particular strength from this account of a family in North Africa is the extent to which it shares the fecal health problems of the family in Southeast Asia. Indeed, unlike many other patterns of disease, there is a sameness about the bulk of the serious, frequently transmitted, excreted infections that cannot be avoided. There are certainly infections that are peculiar to particular localities, but the pattern of diarrheal disease, enteric fever, numerous viral infections, and the intestinal worms is repeated throughout the world. Cholera is the only excreta-related disease of major importance that has a variable and patchy distribution.

Excreted Infections

As these examples illustrate, excreta are related to human disease in two ways. First, the agents of many important infections escape from the body in excreta and may eventually reach other people. These are called the excreted infections. In some cases the reservoir of infection is almost entirely in animals other than man. These reservoirs are not considered here because such infections cannot be controlled through changes in human excreta disposal practices. A number of infections for which both men and other animals serve as a reservoir are included, however.

The second way in which excreta relate to human disease is by their disposal, which can encourage the breeding of insects. These insects may be a nuisance

in themselves (flies, cockroaches, mosquitoes); they may transmit excreted pathogens mechanically, either on their bodies or in their intestinal tracts (cockroaches and flies); or they may be vectors for pathogens that circulate in the blood (mosquitoes). Where flies or cockroaches are acting as vehicles for the transmission of excreted pathogens, this represents a particular instance of the many ways in which excreted pathogens may pass from anus to mouth.

In considering the transmission of excreted infections, the distinction between the state of being infected and the state of being diseased must be kept in mind. Very often the most important section of the population involved in transmitting an infection shows little or no sign of disease; conversely, individuals with advanced states of disease may be of little or no importance in transmission. A good example of this distinction occurs in schistosomiasis, in which as much as 80 percent of the total egg output in feces and urine reaching water from a human population may be produced by children five to fifteen years old; many of these children will show minimal signs of disease. Conversely, adults with terminal disease conditions may produce few or no viable eggs.

If an excreted infection is to spread, an infective dose of the relevant agent has to pass from the excreta of a case, carrier, or reservoir of infection to the mouth or some other portal of entry of a susceptible person. Spread will depend upon the numbers of pathogens excreted (excreted load), upon how these numbers change during the particular transmission route or life cycle, and upon the dose required to infect a new individual. Infective dose is in turn related to the susceptibility of the new host. Three critical factors govern the probability that, for a given transmission route, the excreted pathogens from one host will form an infective dose for another. These are latency, persistence, and multiplication. Diagrammatically, we can represent the concepts thus:

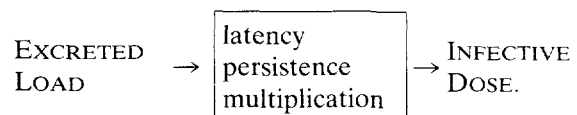

These concepts are discussed in turn.

Excreted load

There is wide variation in the concentration of pathogens passed by an infected person. For instance, a person infected by a small number of nematode worms may be passing a few eggs per gram of feces, whereas a cholera carrier may be excreting

more than 10^8 *Vibrio cholerae* per gram, and a patient may pass 10^{13} vibrios per day.

Where large numbers of organisms are being passed in the feces, they can give rise to high concentrations in sewage. Thus, even in England, where water use is relatively high and salmonellosis relatively rare, raw sewage may contain 10^4 *Salmonella* per liter. At these concentrations, removal efficiencies of 99 percent in conventional sewage treatment works will still leave 10^2 pathogenic organisms per liter in the effluent, and their implications for health will depend upon their ultimate disposal, their ability to survive or multiply, and the infective dose required.

Latency

Latency is the interval between the excretion of a pathogen and its becoming infective to a new host. Some organisms, including all excreted viruses, bacteria, and protozoa, have no latent period and are immediately infectious when the excreta are passed. The requirements for the safe disposal of excreta containing these agents are far more stringent than for those helminthic infections in which there is a prolonged latent period. In particular, infections that have a considerable latent period are largely risk free even where night soil is being carted by vacuum truck, whereas the others constitute a major health hazard in fresh night soil. Therefore, in the classification presented below, the first two categories, in which no latency is observed, are separated from the remaining categories, where a definite latent period occurs.

Among the helminthic infections, only three have eggs or larvae that may be immediately infectious to man when passed in the feces. These are *Enterobius vermicularis*, *Hymenolepis nana*, and, sometimes, *Strongyloides stercoralis*. The remaining excreted helminths all have a distinct latent period, either because the eggs must develop into an infectious stage in the physical environment outside the body or because the parasite has one or more intermediate hosts through which it must pass in order to complete its life cycle.

Persistence

Persistence, or survival, of the pathogen in the environment is a measure of how quickly it dies after it has been passed in the feces. It is the single property most indicative of the fecal hazard in that a very persistent pathogen will create a risk throughout

most waste treatment processes and during the reuse of excreta.

A pathogen that persists outside the body for only a very short time needs to find a new susceptible host rapidly. Hence, transmission cannot follow a long route through sewage works and the final effluent disposal site back to man but, rather, will occur within the family by transfer from one member to another as a consequence of poor personal hygiene. More persistent organisms can readily give rise to new cases of disease farther afield, and as survival increases, so also must concern for the ultimate disposal of the excreta. In addition, pathogens that tend to persist in the general environment will require more elaborate processes if they are to be inactivated in a sewage works. Methods of sequestering them—for example, by sedimentation into a sludge that receives special treatment—are often needed.

Although it is easy to measure persistence or viability of pathogenic organisms by laboratory methods, to interpret such results it is necessary to know how many are being shed in the excreta (which is relatively easy to determine) and the infective doses for man (which is extremely difficult to discover).

Multiplication

Under some conditions certain pathogens will multiply in the environment. Thus, originally low numbers can be multiplied to produce a potentially infective dose. Multiplication can take the form of reproduction by bacteria in a favorable environment (for example, *Salmonella* on food), or of the multiplication by trematode worms in their molluscan intermediate hosts.

Among the helminths transmitted by excreta, all the trematodes infecting man undergo multiplication in aquatic snails. This introduces a prolonged latent period of a month or more while development is taking place in the snail, followed by an output of up to several thousand larvae into the environment for each egg that reaches a snail.

Infective dose

In principle, from a knowledge of the output of pathogens in the excreta of those infected, the mean infective dose, and the extractive efficiency of the excreta treatment process, it would be a matter of simple calculation to assess risk. The real world is much less predictable than this because of the variable infective dose of most pathogens and the uneven distribution of infection in the environment. While

the minimal infective dose for some diseases may be a single organism, or very few, the doses required in most bacterial infections are much higher. Data bearing on this are very hard to acquire, since they involve administering a known dose of a pathogen to a volunteer. Information is scanty, and generally concerned with doses required to infect at a single exposure a very large proportion (say half) of those exposed, rather than a minute proportion. The volunteers have usually been well-nourished adults from nonendemic areas. Such results therefore have to be applied with considerable caution (if, indeed, they can be applied at all) in estimating doses that would cause disease in a small proportion of, say, malnourished children continuously exposed to infection.

Host response

This is important in determining the result of an individual's receiving a given dose of an infectious agent. In particular, acquired immunity and the relation of age to pathology are important for predicting the effects of sanitation improvements. In general the balance between exposure to infection and a host's response to it will determine the pattern of excreta-related disease. If transmission, creating exposure to a particular infection, is low, then few people will have encountered the infection; most will be susceptible. If a sudden increase in transmission of the disease occurs, it will affect all age groups in epidemic form. Improvements in sanitation will have a great effect under these circumstances by reducing the likelihood of an epidemic and, should one occur, its magnitude.

By contrast, if transmission is very high, all the people will be repeatedly exposed to the infection and first acquire it in childhood. Subsequent exposures may be without effect if long-lasting immunity is acquired from the first attack. Alternatively, immunity may be cumulative from a series of attacks. The infection will always be present and is described as endemic. Under these conditions much transmission is ineffective because of human acquired immunity, and reduced transmission as a result of improved sanitation will only delay the date of infection till later in life. Extensive sanitary improvements will either render the infection rare or, if the disease originally were highly transmitted, make it an adult disease. An example of the first case is typhoid, which can be completely prevented in the community by adequate management of excreta and of water supplies. An example of the second is poliomyelitis virus infection, which requires extreme hygienic pre-

cautions to prevent, so that in practice improved sanitation increases the disease problem by deferring infection to an age where its clinical course is more severe.

The prevalence of disease among juveniles makes this group the main sources of infection; the acute need for better community excreta disposal is therefore among young children, the group perhaps least inclined to use any facilities that may be available.

Nonhuman hosts

Some excreted diseases (for example, shigellosis) are infections exclusively or almost exclusively of man; it is then the control of human excreta that is important in preventing transmission. Many, however, involve other animals either as alternatives to man as host or as hosts of other stages in the pathogen's life cycle. In the first case, where wild or domestic vertebrate animals act as alternative hosts (such infections are called zoonoses), control of human excreta is not likely to suffice for complete prevention of the infection. In the second case, some excreted helminthic infections have intermediate aquatic hosts. These infections will therefore be controlled if:

- Excreta are prevented from reaching the intermediate host
- The intermediate hosts are controlled
- People do not eat the intermediate host uncooked or do not have contact with the water in which the intermediate host lives (depending on its particular life cycle).

Environmental Classification of Excreted Infections

The lists of human pathogens in excreta given in tables 2-1 and 2-2 are useful only to the degree they show the wide variety of excreta-related pathogens and the membership of pathogens in one of four groups of organisms: viruses, bacteria, protozoa, and helminths. It is essentially a biological classification. To the sanitation program planner it is interesting, but not very helpful. An environmental classification, which groups excreted pathogens according to common transmission characteristics, is much more helpful in predicting the health effects of sanitation improvements and in understanding the health aspects of excreta and sewage treatment and reuse processes. The environmental classification (table 2-

Table 2-3. *Environmental Classification of Excreted Infections*

<i>Category and epidemiological feature</i>	<i>Disease</i>	<i>Environmental transmission focus</i>	<i>Major control measure</i>		
I. Nonlatent; low infective dose	Amebiasis	Personal	Domestic water supply Health education Improved housing Provision of toilets		
	Balantidiasis	Domestic			
	Enterobiasis				
	Enteroviral infection ^a				
	Giardiasis				
	Hymenolepiasis				
	Infectious hepatitis				
II. Nonlatent; medium or high infective dose; moderately persistent; able to multiply	Rotaviral infection		Domestic water supply Health education Improved housing Provision of toilets Treatment of excreta before discharge or reuse		
	<i>Campylobacter</i> infection	Personal			
	Cholera	Domestic			
	Pathogenic <i>Escherichia coli</i> infection	Water			
	Salmonellosis	Crops			
	Shigellosis				
	Typhoid				
	Yersiniosis				
	III. Latent and persistent; no intermediate host	Ascariasis		Yard	Provision of toilets Treatment of excreta before land application
		Hookworm infection ^b		Field	
Strongyloidiasis		Crops			
Trichuriasis					
IV. Latent and persistent; cow or pig as intermediate host	Taeniasis	Yard	Provision of toilets Treatment of excreta before land application Cooking; meat inspection		
		Field			
		Fodder			
V. Latent and persistent; aquatic intermediate host(s)	Clonorchiasis	Water	Provision of toilets Treatment of excreta before discharge Control of animal reservoirs Cooking		
	Diphyllobothriasis				
	Fascioliasis				
	Fasciolopsiasis				
	Gastrodiscoidiasis				
	Heterophyiasis				
	Metagonimiasis				
	Paragonimiasis				
VI. Excreta-related insect vectors	Schistosomiasis	Various fecally contaminated sites in which insects breed	Identification and elimination of suitable insect breeding sites		
	Bancroftian filariasis (transmitted by <i>Culex pipiens</i>) and all infections in I-V for which flies and cockroaches can be vectors ^c				

Source: Feachem and others (forthcoming).

a. Includes polio-, echo-, and coxsackieviral infections: poliomyelitis; viral meningitis; diarrheal, respiratory, and other diseases (see Feachem and others, chapter 1).

b. *Ancylostoma duodenale* and *Necator americanus*.

c. *Culex pipiens* is a complex of mosquito species and subspecies. The principal tropical species, and the vector of filariasis in those tropical areas where the infection is transmitted by *Culex*, is *Culex quinquefasciatus* (previously also known as *Culex pipiens fatigans*, *C. p. quinquefasciatus*, or *C. fatigans*). See map 19 in Kalbermatten, Julius, and Gunnerson (1982) for distribution of the complex.

3) developed in Feachem and others (forthcoming) distinguishes six categories of excreted pathogens.

Category I

These are the infections that have a low infective dose (less than 100 organisms) and are infective immediately on excretion. These infections are easily

spread from person to person wherever personal and domestic hygiene are poor. Therefore, it is likely that changes in excreta disposal technology will have little if any effect on the incidence of these infections if the technological changes are unaccompanied by sweeping changes in hygiene, which may well require major improvements in water supply and housing, as well as major efforts in health education. The

important aspect of excreta disposal for the control of these infections is the provision of a hygienic toilet of any kind in or near the home so that people have somewhere to deposit their excreta. What subsequently happens to the excreta (how wastes are transported, treated, and reused) is of less importance because most transmission will occur in the home. Although transmission can, and does, occur by complex routes, most transmission is directly person-to-person, and therefore the provision of hygienic toilets alone will have a negligible effect. The control measures appropriate to categories I and II, however, merge into each other and really form a continuum (see below). In particular, the parasitic protozoa share some features of each group. The extreme example of a category-I pathogen is the pinworm, *Enterobius vermicularis*, whose sticky eggs are laid by emerging females on the anal skin so that autoinfection is predominantly by way of scratching fingers and not by eggs in the feces. At the other extreme, *Giardia lamblia* has been associated with well-documented waterborne diarrheal outbreaks, and therefore is presumably in part subject to control by excreta management.

Category II

The infections in this category are all bacterial. They have medium or high infective doses ($>10^4$) and therefore are less likely than category-I infections to be transmitted by direct person-to-person contact. The pathogens in this category are persistent and can multiply, so that even the small numbers remaining a few weeks after excretion can, if they find a suitable substrate (such as food), multiply to form an infective dose. Person-to-person routes are important but so too are other routes with longer environmental cycles, such as the contamination of water sources or crops with fecal material.

The control measures listed under category I in table 2-3 are important (namely, water supply, housing, health education, and the provision of hygienic latrines), but so also are waste treatment and reuse practices. Changes in excreta disposal and treatment practices alone may reduce the incidence of cholera, typhoid, amebiasis, certain shigelloses, and infections due to *Balantidium coli* and species of *Hymenolepis* and *Yersinia*, but such changes are unlikely to be effective against enteroviral infections, salmonellosis (other than typhoid), and infections due to *Shigella sonnei*, *Giardia*, *Enterobius*, and enteropathogenic *Escherichia coli*, since these latter pathogens are still commonly transmitted within affluent communities in industrialized countries.

The criteria chosen to separate the pathogens of categories I and II are infective dose and "length" of the environmental cycle, since the objective of environmental classification is to predict the efficacy of sanitation improvements as a control measure. The reason these pathogens do not form distinct groups is the variable persistence of the organisms. The extreme category-I pathogen, which has a low infective dose and is environmentally fragile, will clearly tend to be spread in an intrafamilial or other close pattern and depend for its control more on personal hygiene than on sanitation. A low infective dose in an environmentally persistent organism, however, will lead to an infection very difficult to control either by sanitation or by personal and domestic hygiene. Many viruses fall into this category and pose major problems of control so that induced resistance by immunization may be the best approach, as discussed above for poliomyelitis. In category II the role of sanitation improvements is to reduce the efficacy of the longer cycles (this would have less overall benefit in the case of category-I pathogens, where these longer cycles are of little significance).

Category III

This category contains the soil-transmitted helminths. They are both latent and persistent. Their transmission has little or nothing to do with personal hygiene, since the helminth eggs are not immediately infective to man. Domestic hygiene is relevant only insofar as food preparation must be adequate to destroy any infective stages present on food, and latrines must be maintained in a tolerable state of cleanliness so that eggs do not remain on the surroundings for the days or weeks of their latent period. If ova are not deposited on soil or other suitable development sites, transmission will not occur. Therefore, any kind of latrine that contains or removes excreta and does not permit the contamination of the floor, yard, or fields will limit transmission. Because persistence is so long, it is not sufficient to stop fresh feces from reaching the yard or fields. Any fecal product that has not been adequately treated must not reach the soil. Therefore, in societies that reuse their excreta on the land, effective treatment (for example, storage of excreta for at least a year) is vital before reuse.

Category IV

This category contains only the beef and pork tapeworms (*Taenia saginata* and *T. solium*, respec-

tively). Any system that prevents untreated excreta from being eaten by cattle and pigs will control transmission of these infections. Cattle are likely to be infected in fields treated with raw sewage or sludge. They may also eat feces deposited in cowsheds. Pigs are likely to become infected by eating human feces, a practice common in areas where swine are employed as scavengers. Therefore the provision of toilets of any kind to which cattle and pigs do not have access and the treatment of all wastes before land application are the necessary control methods. It is also necessary to prevent birds, especially gulls, from feeding on trickling filters and sludge drying beds and subsequently depositing tapeworm ova in their droppings on pastures. Personal and domestic cleanliness are irrelevant, except in the use of toilets.

Category v

These are the water-based helminths that need one or more aquatic hosts to complete their life cycles. Control is achieved by preventing untreated excreta or sewage from reaching water in which these intermediate hosts live. Thus, any land application system or any dry composting system will reduce transmission. There are two complications. First, in all cases except *Schistosoma mansoni* and *S. haematobium*, animals are an important reservoir of infection. Therefore, any control measures restricted to human excreta can have only a partial effect. Second, in the case of *S. haematobium* it is the disposal of urine that is of importance, and this is far more difficult to control than the disposal of feces. Because multiplication takes place in the intermediate hosts (except in the case of the fish tapeworm, *Diphyllobothrium latum*), one egg can give rise to many infective larvae. A thousandfold multiplication is not uncommon. Therefore, effective transmission may be maintained at very low contamination levels, and the requirements of adequate excreta disposal, in terms of the percentage of all feces reaching the toilet, are very exacting.

Category VI

This category is reserved for excreted infections that are, or can be, spread by excreta-related insect vectors. The most important and ubiquitous of these vectors are mosquitoes, flies, and cockroaches. Among the mosquitoes there is one cosmopolitan tropical species, *Culex quinquefasciatus*, which preferentially breeds in highly contaminated water and is medically important as a vector of the worms that

cause filariasis. The other two groups, flies and cockroaches, proliferate where feces are exposed. Both have been shown to carry large numbers and a wide variety of excreted pathogens on their feet and in their intestinal tracts, but their importance in actually spreading disease from person to person is in fact controversial, though their nuisance value is great. Flies have been implicated, however, in the spread of eye infections and infected skin lesions.

The implied control measure is to prevent access of the insects to excreta. This can be achieved by many sanitation improvements of differing sophistication. In general, the simpler the facility, the more care is needed to maintain it insect-free.

Health Benefits of Sanitation Improvements

The theoretical potential for control of excreted infections by sanitation improvements alone and by personal hygiene improvements alone, by environmental category of infection, is:

	Sanitation alone	Personal hygiene alone
I	Negligible	Great
II	Slight to moderate	Moderate
III	Great	Negligible
IV	Great	Negligible
V	Moderate	Negligible
VI	Slight to moderate	Negligible

Table 2-3 gives additional control measures for categories I through VI. The outstanding difference is between categories I and II together, which depend so strongly on personal and domestic hygiene, and the other categories, which do not. Category-I and -II infections are thus much more likely to be controlled if water availability is improved concurrently with sanitation and if an effective and sustained program of hygiene education is organized. If improvements are made only in the water supply, there will be some reduction in the incidence of category-I and -II infections, but the full health benefits of the water supply improvements will not be realized until excreta disposal improvements are made as well.

If one considers the changes necessary to control category-III and -IV infections, they are relatively straightforward: the provision of toilets that people of all ages will use and keep clean and the effective treatment of excreta and sewage prior to discharge or reuse. The reason why the literature on the effects of latrine programs often does not show a marked decrease in the incidence of category-III through -VI

infections is because, although latrines were built, they were typically not kept clean and often not used at all by children or by adults when working in the fields.

Sanitation improvements are thus necessary but in themselves are not sufficient for the control of excreted infections. Without them, excreted infections can *never* be controlled. But other complementary inputs, such as improved water supplies and sustained hygiene education programs, are essential for success. In some cases, the provision of sanitation improvements and these complementary inputs for the urban and rural poor may necessitate major social and economic changes.

Excreted Infections and Children

Many of the excreted infections have a markedly nonuniform distribution of prevalence among different age groups. Although all of them are found among people of all ages, many are concentrated in particular age groups. Many are primarily infections of childhood, or they afflict children as well as adults; relatively few are restricted to adults only. This has great relevance for disease control through sanitation improvements, especially in areas where infant and child mortality is high.

In all societies children below the age of about three years will defecate whenever and wherever they feel the need. A proportion of these children will be excreting substantial quantities of pathogens. In some societies the stools of these children are regarded as relatively inoffensive, and the children are allowed to defecate anywhere in or near the house. In this case it is highly likely that these stools will play a significant role in transmitting infection to other children and adults. For example, habits of children that determine the degree of soil pollution in the yard and around the house will largely determine the prevalence and intensity of ascariasis in the household. In contrast, in some other societies strenuous efforts are made to control and manage the stools of young children, either by making them wear diapers or by cleaning up their stools wherever they are observed. Either of these reactions will have an important controlling influence on the intrafamilial transmission of excreted pathogens.

Between these two extremes there is a whole range of intermediate behavioral patterns with regard to the reaction of adults to the stools of young children. In most poor communities the picture is closer to the first example than to the second. It is important that

government and other concerned agencies respond to this situation through health education of parents to encourage a belief that the stools of young children are dangerous and require hygienic disposal. Although the problem is primarily connected with parental attitudes and behavior, the provision of some form of toilet for the disposal of children's stools and, perhaps more important, a convenient water supply will greatly assist child hygiene.

Children over three years old are capable of using a toilet if one of suitable design is available. Children in the age range of three to twelve frequently do not use toilets, even where they are available, because:

- They find it inconvenient and are not encouraged to use them by adults
- They are afraid of falling down the hole or of being attacked by domestic animals or rodents that may live next to the latrine
- They cannot, because the toilet is physically too big for them
- They are prevented from doing so by adults who do not want children "messing up their nice clean toilet."

As with the very young children, it is of vital importance that the stools of these children are hygienically disposed of because some of them will be rich in pathogens. The solution lies in a combination of the provision of a toilet that children are happy to use and hygiene education for the parents so that they compel their children to do so. Education at school can also be effective, and it is vitally important that all schools have well-maintained latrines of a good design so that the children may learn from positive experience (but this will be of little benefit without reinforcement from the parents and the availability of a toilet in the home).

Groundwater Pollution from On-site Excreta Disposal

On-site disposal of human waste presents a potential hazard of groundwater contamination and, thus, disease transmission from the disposal site through groundwater to users of well water. Contaminants are pathogens (bacteria, viruses, protozoa, helminths) and inorganics (principally chlorides and, in areas where baby formulas replace breastfeeding, nitrates).

The severity of contamination and the distance pollutants travel depend on factors such as soil type and porosity, distance to and type of underlying rock,

groundwater level and hydraulics, composition of waste (presence and characteristics of contaminants), natural contaminant removal processes (filtration, dispersion, sorption), distance to surface water, and the like. The effects on people depend on the type of water service (individual shallow or deep wells, piped systems and their water sources), climate, and so forth.

Clearly, the most serious problem exists where a latrine penetrates the groundwater that provides drinking water through shallow wells located nearby. In such a situation, vault latrines should be used or the water piped to standpipes from a protected well. The most favorable situation exists where the water supply is already a piped system, latrines do not reach groundwater, and soil porosity is low.

It is not possible to establish detailed, universally valid guidelines for horizontal and vertical separation of latrines, drainfields, and wells. Much further work is required to determine the travel distance and survival of pathogens entering the soil through latrines. It is clear, however, that the greater the groundwater abstraction, the more porous or fissured the soil, the greater the distance should be between a latrine and a well. It is generally accepted practice to keep a minimum distance of 10 meters between latrine and well in loam or sandy silt soils. Where wells are equipped with mechanical pumps and supply a large number of people, a groundwater study should investigate and subsequently monitor both water quan-

tity and quality. Such studies, and necessary corrective measures, are beyond the topic of this manual. Qualified professionals should be consulted.

The inorganic pollutant of concern is nitrate, which occurs in groundwater as a result of natural and man-made pollution. Nitrates do not appear to affect adults even at levels far higher than those specified in the World Health Organization (WHO) drinking water standards, but bottle-fed infants contract methemoglobinemia at nitrate levels considerably below the WHO standard. As a consequence, it is suggested that where groundwater contains more than 10 milligrams per liter of nitrate nitrogen and where the local water supply is used in preparing infant formulas, the local health officer be consulted to determine the possible effect on infants. Where infants are bottle fed, acidified milk powder or other nutritional changes are available to cure or prevent methemoglobinemia.

Notes to Chapter 2

1. Much of this chapter is taken from Feachem and others (1980); for a more thorough examination of the issues discussed, see Feachem and others (forthcoming).

2. *Culex pipiens* is a complex of mosquito species and subspecies. The principal vector of filariasis (elephantiasis) in the tropical areas in which the disease occurs is *Culex quinquefasciatus* (previously also known as *Culex pipiens fatigans*, *C.p. quinquefasciatus*, or *C. fatigans*).

3

Community Participation

THIS CHAPTER is concerned with the individual household and community aspects of sanitation program planning.¹ Failure to involve the community that is intended to benefit will almost certainly result in failure of the project. For example, government efforts, extending from 1930 to 1944 and repeated in 1958 and 1974, that tried to impose latrines on a Central American village had by 1977 a success rate of only 11 percent. In contrast, two villages in the same country responded to their own leaders with such enthusiasm that 65 and 85 percent of the villagers now use self-built latrines. At the other end of the scale, both an East Asian and a West African city spent considerable sums to construct sewers that are largely unused because the intended beneficiaries have chosen not to connect to them.

Although it is true that possibilities and approaches for community participation are different for villages and cities, personal contacts and dialogue are important in both. The long-range objective of community participation in sanitation program planning is to ensure that the technology selected matches the preferences and resource constraints of the beneficiaries. The technology must satisfy householders' needs at a cost they are willing to pay. To this end, it is necessary that the considerations and practices presented in this chapter be applied by people who are familiar with tried social science techniques and who have a cultural background similar to that of the intended users.

Community participation alone is not sufficient for the successful design and implementation of a sanitation program. Institutional support by government—national, state, and local—is needed to supply technical expertise and support services not available in the community. For example, the community worker conducting interviews and the technician designing and supervising installation of facilities are generally employees of the institution responsible for sanitation in the area. Other services

that the supporting agency has to provide are the purchase and delivery of materials, water resource surveys, drilling of wells, and the like.

A discussion of institutional and organizational managements needed to support the community participation is beyond the scope of this manual. Those interested will find the details in a companion volume (Kalbermatten, Julius, and Gunnerson 1982).

Characteristics of Community Participation

Community participation should ordinarily include six phases. The first three should be undertaken at the very beginning of project development (they are part of stage 1 in figure 1-1), the fourth toward the end of the selection phase (stage 6 of figure 1-1), and the final two depend upon technical requirements and opportunity patterns. In the first phase unstructured interviews are conducted with a few local leaders (such as political officials, religious leaders, and school teachers) and a small number of households. The purpose of these preliminary interviews is to identify user attitudes and other factors that are likely to determine the engineering design and acceptance criteria listed below. In this phase it is essential to determine what kind of description or model of a technology is needed for the householders to understand it. A socially acceptable glossary of terms relating to defecation also must be prepared so that local sensitivities and taboos may be protected, and local communication channels and boundaries should be defined. In the second phase a community questionnaire is designed and tested.

The kinds of information this questionnaire should elicit include:

- The desire of the community for sanitation and water supply improvements, expressed as will-

ingness to contribute to the costs through cash contributions, labor and materials, or both

- Preference for private or communal latrines (for example, do the latter represent alternatives to defiling orthodox Buddhist households or do they lead to crowding and quarreling?)
- Health, sickness, and nuisance as they are perceived to be affected by water supply and sanitation practices
- Attitudes toward convenience as measured by latrine or standpipe location, abundance or capacity of water supply systems, and reliability of service
- Preferences for color, taste, odor, temperature, and the like in water quality
- Aesthetic features of sanitation alternatives such as superstructure color and materials or squatting plate design
- Attitudes toward visibility, means of removal, and so forth, of stabilized wastes, and toward conservation, reuse, or reclamation (biogas, fertilizer, aquaculture, stock and garden watering, and the like) of wastes
- Importance attached to local autonomy that might be lost if a higher authority were to assume part or all of the responsibility for funding, fee collection, construction, operation, and maintenance of the improved facilities
- Community or peer pressure for joining and supporting "unity and progress" groups and the like
- Confidence in local or visiting political and technical authorities.

Other factors about which information is essential for design or implementation include land tenure and the customary manner in which local committees are formed.

In the third phase, structured interviews are conducted using the questionnaire developed (and modified if necessary) in the second phase. At least thirty households should make up the sample to be interviewed, and care must be taken to ensure that they are representative of the social and income groups of the community; information gained in the unstructured, preliminary interviews usually can be used to select representative households.

Interviews should include women because they are both knowledgeable about water use and responsible for training children in personal hygiene and sanitation. It should always be remembered by the interviewer that the most reliable comprehensive answers to questions on sanitation will come from those

who are most concerned about sanitation. If, for example, land tenure or employment is found to be a problem during unstructured parts of an interview, sanitation problems will get little attention from the householder. This in turn may indicate little preoccupation with sanitation within the community and augur ill for any eventual program.

After the formal interviews, the responses should be evaluated by the program's behavioral scientist. This information is then used by the engineer and economist to develop a list of socially acceptable, technically feasible, least-cost alternatives.

In the fourth phase, a meeting should be held between the program's behavioral scientist and the community or its representatives at which the former presents the alternative technologies and their costs. Photographs and other visual aids, working models, visits to other communities, or a combination of these should be used, particularly in areas where written communication is not common. The benefits of each service level and the manner in which each alternative can be upgraded should be presented. At a follow-up meeting conducted at an early date, a technology option or options should be selected. If necessary, limited demonstration projects may be built and operated. In any event, community choice and willingness to pay should be determined as soon as possible.

If a significant proportion of the community population (say, 50 percent) is not interested in cooperating in a sanitation project by the end of the community participation and assessment program, it will ordinarily be better to shift the project and resources to another community. Two additional warnings are in order. First, important differences between community preference and design or service level, whether for higher or lower levels of service, are seldom resolved by more education or information. Second, schemes that depend on wealthier individuals' involuntarily supporting sanitation services for others ordinarily do not work. For example, wealthy homeowners are not likely to abandon operating septic tanks and pay high sewer connection charges so that poor neighborhoods can be served by the same sewer system.

The fifth phase occurs either in parallel with the technology selection or as a result of it. The community will have to organize the implementation and subsequent operation and maintenance of the facilities to be constructed. If there is a formal organizational structure in the community, it may be used to organize project implementation and operation. If no structure exists, special arrangements will have

to be made for the project. These can vary from the selection of a local craftsman to check a piece of equipment periodically to the hiring of full-time staff to operate and maintain a communal facility. Just as in the selection of the technology, the type of organizational arrangement should be a community decision.

Construction work should be performed with the assistance of the technician of the technical support agency, but under local leadership if possible. It is important that the community ensures that some of its members are trained by the technician during this process.

Some requirements for a successful construction program are the selection of sites for communal and private facilities; the purchase of materials not available in the community; the distribution of materials needed to construct individual facilities; prompt delivery by the community of materials provided in lieu of cash contributions; organization of work parties and maintenance of records of time, cash, or materials provided by community members; supply of technical assistance for the construction and initial operation of the facilities; and external input from the technical support agency.

Phase six is the operation and maintenance of the facilities. In the case of communal systems, this involves regular operation, maintenance, occasional repairs, and the collection of funds to pay for recurrent expenses. In addition, performance should be monitored by the technical agency, in collaboration with the community, and information disseminated to other communities so that lessons learned from the success or failure in one can be used in the design and implementation of programs in others. The program should also include exchange visits by those responsible for operation and maintenance in various communities and, if systems are large or sophisticated enough, the training of local personnel at regional agency headquarters. Any training not accomplished during phases four and five should take place now, and the relation between the operators and the technician should be established. The latter should make periodic visits to the community to help solve minor problems, provide routine technical assistance, order spare parts, and mobilize additional support if major problems arise. Regular visits should be made at short intervals in the beginning and at least once a month after the community has become familiar with the tasks of operating the facilities. Provision also should be made for rapid contact in cases of emergency (failure of equipment, suspected water contamination, and the like).

Institution-Community Linkage

Many aspects of community participation in sanitation program development depend upon and influence institutional structures. Although it has been assumed that the necessary institutional support exists, it may be useful to conclude this chapter with a simplified description of the institutional steps required to facilitate and support involvement of the community:

- Establish a support unit for water supply and sanitation in existing regional agencies or form an independent support unit. The staff will represent a mix of disciplines and will probably include engineers, hydrogeologists, a behavioral scientist, an economist, accountants, plumbers, mechanics, electricians, well drillers, purchasing agents, and health educators.
- Establish design and operating standards and village selection and priority criteria, conduct specialized tasks such as hydrogeological surveys, management training, operating assistance, and the like.
- Train community workers in low-cost water supply and sanitation technology, hygiene promotion, and community organization.
- Train community workers in health care and nutrition.
- Canvass and organize selected communities. Plan, design, and implement prototype projects to complete the training of community workers.
- Assign community workers in teams to designated areas to canvass and organize communities.
- Assist communities in constructing facilities.
- Maintain a limited number of community workers as roving operation and maintenance advisers and monitors for completed projects. Assign all other community workers to new areas where successful projects can be replicated.
- Provide technical assistance through a support unit. Maintain a stock of spare parts administered by the support unit.
- Monitor the operation and quality of service, disseminate information, and provide continuous training programs for community workers and local staff.

In summary, the degree of community participation and willingness to pay for improved service levels by contributions of money, labor, or materials

depends fundamentally upon household income levels and perceived needs. Whether a feasibility study results in a project that properly meets the needs of the community depends on the accuracy, completeness, and timeliness of information exchanged between the residents and those who are conducting the feasibility study. The analysis of social factors and conduct of the interviews should be the respon-

sibility of people accepted by the community: these tasks are too important to be entrusted to strangers.

Note to Chapter 3

1. For a more thorough discussion of these issues, see Kalbermatten, Julius, and Gunnerson (1982).

4

Economic Analysis of Sanitation Technologies

ONCE THE TECHNOLOGIES that are technically infeasible for the site being considered have been eliminated by the project engineer, it is necessary to rank the remaining technically feasible technologies by some meaningful scale so that the most appropriate one may be selected.¹ Implicit in this is the need for a common basis for the objective comparison of the remaining technologies that reflects both the positive and negative consequences of adopting each of them.

Ideally, a cost-benefit analysis should be used to rank alternatives, but, as is true of many public services, it is impossible to quantify most of the benefits (such as those of improved health and user convenience) of a sanitation system. In general, there is no completely satisfactory way to get around this difficulty. Only in the case of mutually exclusive alternatives with *identical* benefits should one always select the one with the least cost. Where there are differences in the levels of service provided by the various alternatives, the least-cost choice will not necessarily be the one that is economically optimal. For this reason a least-cost comparison will not normally provide sufficient information to select the most appropriate sanitation technology. Nonetheless, if properly applied, it will provide a reasonably objective basis for comparison that reflects the cost tradeoffs corresponding to different levels of service. Once comparable cost data have been developed, the users or their community representatives can make their own determination of how much they are willing to pay to obtain various standards of service.

Economic Costing

The basic purpose behind the economic costing of sanitation technologies (or the economic costing of any other development activity) is to give policymakers a basis for their decisions by providing a price tag for a given level of service that represents the

opportunity cost to the national economy of producing that service. Three principles must be followed in preparing estimates:

- All relevant costs must be included.
- Each cost must be properly evaluated.
- The assumptions used for costing different technologies must be mutually consistent.

The first principle of economic costing is that *all* costs to the economy, regardless of who incurs them, should be included. In comparing the costs of different sanitation technologies, too often only those costs met by the administrative (usually municipal or state) authority are considered in the cost comparison. The costs borne by the household or the costs of complementary services (for example, water for flushing) are often ignored. In the analysis of the *financial* implication for the authority of alternative technologies, such a comparison would be appropriate. For an *economic* comparison, however (that is, for the determination of the least-cost technology with respect to the national economy), it is necessary to include all costs attributable to a given alternative irrespective of whether they are borne by the household, the administrative authority, the national government, or whomever. Some financial costs should be excluded from the economic comparison. Examples of costs that should be ignored are subsidies and taxes, since these represent a transfer of money within the economy rather than a cost to it.

The determination of which costs to include should rest on a comparison of the situation over time both with and without the project. This is not the same as a simple “before and after” comparison. Rather than using the status quo as the “without” scenario, it is essential to estimate how the current situation would improve or deteriorate over the project period if the project were *not* to be undertaken. In addition, a broad enough view of the project must be taken so that all relevant costs will be included. For ex-

ample, a cost that is often ignored when costing sewerage systems is the cost of the additional water that will be required for flushing.

Once the relevant costs have been identified, the second principle of economic costing concerns the prices that should be used to value these costs. Since the objective of economic costing is to develop figures that reflect the cost to the national economy of producing a good or service, the economist is concerned that unit prices represent the actual resource endowment of the country. Thus a country with abundant labor will have relatively inexpensive labor costs in terms of the alternative production possibilities of its labor. Similarly, a country with scarce water resources will have expensive water costs, in the economic sense, regardless of the regulated price charged to the customer. Only by using prices that reflect actual resource scarcities can one ensure that the least-cost solution will make the best use of a country's physical resources.

Because governments often have sociopolitical goals that may be only indirectly related to economic objectives, some market prices may bear little relation to real economic costs. For this reason it is sometimes necessary to adjust market prices in the economic costing exercise so that they represent more accurately "real" unit costs (in the sense of reflecting the effect of these costs on the national economy). This adjustment of market prices to reflect opportunity costs is sometimes known as "shadow pricing."

The calculation of these shadow rates, or conversion factors, is a difficult task that requires intimate knowledge of a country's economy. It is rarely (if ever) worthwhile for an economist or engineer involved with sanitation program planning to take the time to collect data and calculate conversion factors directly. Rather, he or she should check with the ministry of planning or economic affairs to see if the figures have already been determined.

In the economic costing of sanitation technologies there are four shadow rates that normally need to be incorporated in the analysis. These are:

- The unskilled labor wage shadow factor
- The foreign exchange shadow factor
- The opportunity cost of capital
- The shadow price of water, land, and other direct inputs.

Each is briefly discussed in turn.

Unskilled labor

Many governments enact minimum wage legislation. The usual effect of this is that unskilled labor

is economically overvalued; that is, the paycheck of an unskilled laborer is higher than that he would receive in the absence of minimum wage legislation. Because his economic value is less than his wage, however, employers will be reluctant to hire him. Thus, where minimum wages are set above the real productivity of unskilled labor, unemployment generally results (of course, unemployment happens for other reasons as well). This means that, if a country has a very large pool of unemployed laborers, the shadow factor for unskilled labor wages might be close to zero because there is almost no cost *to the national economy* that results from employment of such people, since they would otherwise be unemployed and so be producing nothing. On the other hand, if a country has few unemployed unskilled workers, then the shadow factor would be 1, as this situation is an indication that the market wage fairly reflects economic value. Generally the shadow factor for unskilled labor in developing countries is in the range of 0.5 to 1.0.

Foreign exchange

Many governments do not permit free movement of the exchange rate of foreign currency for their national currency in the international money markets. Instead they fix its value, often in terms of the currency of a major trading partner such as the United Kingdom or Japan. As a result, the currency is sometimes overvalued; imports thus cost fewer units of the national currency than they would if the government allowed the currency to trade freely on the international market, and exports are overpriced in foreign currency value. Sometimes this same result is achieved not by an overvalued domestic currency but by a system of import restrictions, export taxes, or both. The foreign exchange shadow factor is the ratio of the shadow exchange rate (what the currency would be worth in a freely trading international market) to the official exchange rate fixed by the government; expressed in this way, the shadow factor is thus greater than 1 whenever the local currency is overvalued or import restrictions are high. Suppose a government fixes its official rate of exchange at 10 units of its national currency (UNC) to the U.S. dollar, but that in the free market 15 UNC would be required to purchase one U.S. dollar; the foreign exchange shadow factor is thus 1.5. Suppose further that a municipality in the same country wishes to import a night-soil vacuum tanker that has a direct foreign exchange cost at the border of \$10,000. It would have to pay only 100,000 UNC for the tanker, but the true economic or "shadowed" cost to the

country's economy is 1.5 times this amount (that is, 150,000 UNC), and this is the cost that should be used in evaluating the economic cost of the night-soil collection system the municipality wishes to adopt.

Opportunity cost of capital

This is defined as the marginal productivity of additional investment in its best alternative use. It can also be thought of as the price (or yield) of capital. In countries where capital is abundant, such as the industrialized countries of Europe, one expects the yield on capital to be relatively low. This is because capital has already been employed in its most productive uses and is now being substituted for labor or other inputs in less and less profitable areas. In many developing countries, however, capital is a scarce commodity and therefore has a high opportunity cost. A government might decide for socio-political reasons to make available loans to householders at a low rate of interest to enable them to build, say, ventilated improved pit (VIP) latrines. The economic cost of this decision is the yield that the government would have received had it invested its capital in the best alternative way; for example, by buying shares in a well-managed industrial enterprise. The opportunity cost of capital is thus expressed as a percentage; in developing countries it usually ranges from 8 percent to 15 percent.

Water, land, and other direct inputs

The prices of some inputs of sanitation systems are controlled by governments or incorporate government subsidies. For example, land for the construction of waste stabilization ponds may be owned by the government because it is near a public airport. The government may decide to transfer it to the sewerage authority for no financial cost. Its *economic* cost, however, should be calculated as what it would have been worth had it been sold on the market to a farmer or industry that wished to locate there. Usually a good approximation of this shadow cost can be obtained by reviewing recent sales records of similar land in the area.

Other prices that may need adjustment to reflect real resource costs are those of publicly produced outputs such as water and power. It is usually not possible to estimate directly what a free market price would be for these items because the government normally has a monopoly in their production. Nevertheless, the shadow price of water or power can be approximated by calculating its average incremental production cost. A good method for doing this is

described below and shown in the appendix to this chapter.

For most developing countries, where labor is abundant but capital and foreign exchange are scarce, the effect of shadow pricing is to decrease the cost of unskilled labor and to increase the cost of both capital and imported goods. Since shadow pricing removes distortions attributable to political decisions (for example, minimum wage legislation, overvaluation of local currencies, and the provision of development capital at low rates of interest), it is extremely valuable in the identification of the most appropriate sanitation technology for the actual resources of the country. An example of the use of shadow pricing in economic costing is given in the appendix to this chapter.

In addition to these adjustments for shadow prices, economic costs differ from financial costs in that they are based on incremental *future* investments rather than average *historical* investments. This principle rests on the idea that costs already incurred ("sunk" costs) should be disregarded in making decisions about future investments. Thus, in analyzing the real resource cost of a given technology, it is necessary to value the components of that technology at their replacement costs rather than at their actual historical prices. In the case of sanitation systems, this is particularly important in the costing of water. Because cities develop their least expensive sources of water first, it generally becomes more and more costly (even excluding the effect of inflation) to produce and deliver an additional liter of water as the city's demand grows. By using the average cost of producing today's water, one is often seriously underestimating the cost of obtaining additional water in the future. The decision to install a conventional sewerage system with high-volume cistern-flush toilets will increase domestic water consumption by around 50 to 70 percent. Thus, in calculating the costs of such an alternative, it is extremely important to value properly the cost of the additional water that will be required. The economic cost of this additional water is its average incremental production cost; it is *not* the cost charged to the consumers or its current average production cost.

The application of these costing principles to sanitation program planning presents several difficulties. The main one is the problem of finding a scaling variable that allows comparison among diverse technologies regardless of their design populations. On-site systems such as improved pit latrines are generally designed for a single family or household. The latrine's lifetime or the intervals between fairly major maintenance work, such as desludging, will depend

on how many people use it. The life of some components (such as the vent pipe), however, may be independent of usage, so that the annuitized per capita construction cost of a latrine used by six people will not be the same as that of one used by ten people. For this reason most costs should be calculated on a per household basis.

It is often difficult to calculate comparable costs when considering low-cost sanitation as an alternative to sewerage. The low-cost facility is fully used almost immediately by its "design population." Many of the components of sewerage, however, exhibit economies of scale and are therefore sized to meet a design flow that usually does not arise for many years. With such a facility all the investment costs are incurred at the beginning of its lifetime, whereas the benefits (services) are realized gradually over time. Just as costs incurred in the future have a lower present value than those incurred today, benefits received in the future are less valuable than those received immediately. In the derivation of per household costs, this means that serving a person five years hence is not worth as much as serving the same person now. To divide the cost of a sewerage system by its design population would greatly *understate* its real per household cost when compared with that of a system that is fully used upon completion.

One of the best methods to overcome this problem of the differing capacity utilization rates of different systems is the average incremental cost (AIC) approach. The per capita (or household) AIC of a sewerage system is calculated by dividing the sum of the present value of construction costs and incremental operating and maintenance costs by the sum of the present value of incremental persons (or households) served; the appropriate equation is:

$$AIC_t = \frac{\sum_{t=1}^{t=T} (C_t + O_t)/(1+r)^{t-1}}{\sum_{t=1}^{t=T} N_t/(1+r)^{t-1}}$$

where t = time in years
 T = design lifetime in years (measured from start of project at $t = 0$)
 C_t = construction costs incurred in year t
 O_t = incremental (from year $t = 0$) operation and maintenance costs incurred in year t
 N_t = additional people or households (from year $t = 0$) served in year t

r = opportunity cost of capital in percent times 10^{-2} .

It is essential that all costs used in the equation have been appropriately shadow priced. Note that, for a system that is fully utilized upon construction, the equation reduces to merely the sum of the annuitized capital costs and annual operating and maintenance costs divided by the design population.

In practice it is often easier to calculate the AIC of a sewerage system on a volumetric, rather than a per capita, basis. The AIC per cubic meter of sewage is calculated from year-by-year projections of the total wastewater flow. The resulting volumetric costs can then be transformed into per capita (and per household) costs using the per capita wastewater flow. An example is given in the appendix to this chapter.

An additional problem in deriving comparable costs for different sanitation technologies is the differing abilities of the technologies to handle sillage. With conventional sewerage, most septic tanks and pour-flush (PF) and aquaprivy systems, sillage is disposed of with the excreta and toilet flushwater. With most of the on-site excreta disposal technologies, sillage must be disposed of into surface or piped storm drainage systems or into soakage pits. If stormwater drains are present (or would be constructed anyway), the incremental construction cost if sillage is to be discharged into them might be very small since they are usually designed to handle flood peaks. It would be necessary to include only the cost of any special modifications needed to enable the relatively small volumes of sillage to enter and flow in the storm drains without nuisance in the dry seasons, the maintenance costs of ensuring that they are not blocked (and so form breeding grounds for mosquitoes), and the environmental cost of the eventual disposal of the sillage into the receiving watercourse. If large amounts of sillage are left to soak into the ground, nuisance and possibly health risks may be created, and these costs should be evaluated and included. Alternatively, separate disposal of sillage may be considered a benefit where populations recycle kitchen and bathwater to irrigate gardens or dampen dust. In such a case, the removal of sillage through the introduction of a sewerage system would involve a cost. In any particular case it is best to compare alternatives that represent approximately the same benefit levels. Thus, if sewerage (including sillage collection) is one alternative, the cost of sillage disposal in, for example, road drains should be included in the cost of other sanitation alternatives *unless* the road drains would be built anyway for flood control, in which case it is necessary only to

include the additional costs incurred as mentioned above. The guiding principle, again, is to compare the conditions with and without the project.

In general, the data necessary for the calculation of comparable economic costs can be collected fairly early in the design process, after preliminary designs have been prepared. This has the advantage of providing an early warning if, as is frequently the case, most of the alternative designs are too costly relative to the resources likely to be available. It thus saves the trouble of preparing final designs for those technologies that are outside the bounds of affordability. Economic costing should therefore be seen as an early screening of the various sanitation technologies that have passed the basic tests of technical and social feasibility.

Financial Costing

The purpose of deriving economic costs is to make a meaningful least-cost comparison among alternatives. Such a comparison is extremely useful to the planner and policymaker. The consumer, however, is much more interested in financial costs; that is, what he will be asked to pay for the system and how the payment will be spread over time. The difficulty in developing financial costs is that they are entirely dependent upon policy variables that can range widely. Whereas economic costs are based on the physical conditions of the community (for example, its abundance or scarcity of labor, water, and so forth) and therefore are quite objective, financial costs are entirely subject to interest rate policy, loan maturities, central government subsidies, and the like. For example, the financial costs of a sanitation system for a community can be zero if the central government has a policy of paying for them out of the general tax fund. Thus, financial costs cannot be used to make judgments about least-cost alternatives.

To promote the economically efficient allocation of resources, financial costs should of course reflect economic costs as closely as possible, given the government's equity goals and the degree of distortion in other prices in the economy. This could be accomplished with sewerage, for example, by setting a surcharge on the connected consumer's water bill that is equal to the AIC of sewerage per cubic meter of water consumed (that is, if 75 percent of water consumption reaches the sewers, the AIC of sewerage per cubic meter would be multiplied by 0.75 to arrive at the water surcharge). In the case of most of the on-site systems, the consumer would pay to construct

the original facility (either in total or through a loan at the interest rate that reflects the opportunity cost of capital) and then pay a periodic sum to cover its operation and maintenance expenses, if any. In cases such as these, the financial cost would be identical to the economic cost except for any taxes and shadow pricing of those inputs that must be purchased in the market. To the extent that the latter account for a significant part of total economic costs, financial costs may be above or below economic costs.

In deriving financial costs in any particular case, it is necessary to talk with central and local government officials to determine their financial policies and noneconomic objectives. If the government places a high priority on satisfying the basic needs of all of its citizens, then it may be willing to subsidize part or all of the construction cost of a simple sanitation system. The general policy of international lending agencies such as the World Bank is that, if the cost of the minimal sanitation facility necessary to provide adequate health is more than a small part of the household income (say, 5 to 10 percent), then the central or local government should attempt to subsidize its construction to make it affordable. Any operation or maintenance costs should be borne by the beneficiary. If, however, some consumers wish to have better or more convenient facilities, they should pay the additional cost themselves. Similarly, if more affluent communities decide that, beyond meeting basic health needs, they wish to safeguard the cleanliness of their rivers or general environment by building a more expensive sanitation system, they should pay for that system either through direct user charges or through general *municipal* revenues. Since the majority of the poorest people in most countries live in rural areas, it is usually not appropriate to subsidize urban services from central tax revenues.

In general, it is necessary to calculate several sets of financial costs based on different assumptions about municipal or central government subsidies. The first set, which is hereafter called the base financial cost, is that which assumes no financial subsidy. For an on-site system with a short construction period and little requirement for municipal maintenance, the engineer's estimate of construction costs (in market prices) is simply annuitized over the life of the facility at the prevailing (market) interest rate. If self-help labor can be used for part of the construction, then the cost of hiring that labor should be subtracted from the total before annuitizing. To this annual capital cost must be added any operating and maintenance costs that will be required. Then this total base financial cost can be compared with

household incomes to check affordability. If the technology is considered affordable by the target population, then the only financial arrangements that will be required at the outset are those necessary to aid consumers in securing loans from commercial and public banks. If the technology's base financial cost is not affordable by the households to be served, and if lower-cost solutions are infeasible or unacceptable, then various options involving increased self-help input, deferred or low-interest loans, partial construction grants, and the like should be used to compute alternative sets of financial costs. Before any of these are offered to the consumer, however, it is obviously necessary to obtain local government funding to cover the financing gap.

The development of financial costs is more difficult for technologies with off-site investments and the accompanying need for centralized management and operation. There is a large body of literature on accounting systems for public utility enterprises, and the subject cannot be fairly summarized in this brief chapter.

Costing of Community Support Activities

The construction cost figures used for both the economic and financial analyses do not include the cost of community organization, hygiene education and technical assistance, and government administrative support, which are not directly related to the construction of the facilities but which are normally provided to complement a water supply or sanitation program. Unless otherwise noted, it is assumed that assistance provided by government for health education and technical assistance is paid for from regular budgetary resources. Where additional assistance is required, the cost should be estimated and specific funding arrangements made. Needs for assistance vary too widely from community to community to permit the estimation of a useful average per capita cost figure.

Appendix. Examples of Economic Costing

Economic costing of a ventilated improved pit (VIP) latrine

Assume that all materials, except the vent-pipe, cement, and reinforcing steel (for the concrete squat-

ting plate), are manufactured locally. Let the costs (in units of national currency, UNC) be:

Local materials	100 UNC
Imported materials	60 UNC.

Assume that skilled labor is used in building the squatting plate and superstructure and for general supervision, and that unskilled labor is used to excavate the pit, to mix the concrete, and generally to assist the skilled labor. Let the costs be:

Skilled labor	30 UNC
Unskilled labor	70 UNC.

Assume that the household can be expected to spend 10 UNC per year on minor repairs and cleaning materials, that the repairs are done by the householder, and that the cleaning material is manufactured locally.

Assume the following:

Unskilled labor shadow factor	0.7
Foreign exchange shadow factor	1.3
Opportunity cost of capital	12.0 percent
Official rate of exchange per U.S. dollar	2.80 UNC
Household size	6 persons.

Assume also that the pit latrine is designed to last ten years and that no items can be reused at the end of that period.

Example

An example of costs calculated from these assumptions is presented in table 4-1. The following points also apply:

- The annuity or capital recovery factor (CRF) can most easily be obtained from a book of financial or compound interest tables or by using a financial calculator. It can also be calculated, however, from the equation:

$$CRF = \frac{r(1+r)^N}{(1+r)^N - 1}$$

where r = opportunity cost of capital in percent $\times 10^{-2}$ and N = design lifetime in years. Here $r = 12$ percent and $N = 10$ years, so that the CRF is 0.177.

- The annuitized annual cost (in UNC) of each capital item is obtained by multiplying its cost (in UNC) by the CRF and by the appropriate shadow factor, if any.
- The annual cost in U.S. dollars is calculated by converting the shadowed local cost at the official rate of exchange.

Table 4-1. *Annual Economic Costs of a Ventilated Improved Pit (VIP) Latrine*

Item	Total cost (UNC)	Lifetime (years)	Shadow factor	Adjusted annual cost	
				UNC	U.S. dollars
Materials					
Local	100	10	None	17.7	6.3
Imported	60	10	1.3	13.8	4.9
Labor					
Skilled	30	10	None	5.3	1.9
Unskilled	70	10	0.7	8.7	3.1
Maintenance	10	1	None	10.0	3.6
Total					
Per household				55.5	19.8
Per capita				9.3	3.3

UNC Units of national currency.

Economic costing of a conventional sewerage scheme

Sewerage costs are divided into two types: household costs, and collection and treatment costs (although collection and treatment costs should be calculated separately, for reasons explained below).

HOUSEHOLD COSTS. These include all the toilet and plumbing fixtures, the connection to the street sewer, and the superstructure (in the case of a toilet located inside the house, this may be calculated as the toilet floor area times the construction cost per square meter—excluding from the latter the toilet and plumbing fixtures, to avoid including these

Table 4-2. *Shadow-priced Collection and Treatment Costs of a Conventional Sewerage Scheme Constructed over Five Years*

Component	Year incurred	Total cost (UNC)
Collection		
Sewers, force mains, manholes	1-5 (evenly)	4,000,000
Pumping stations ^a	5	400,000
Engineering design	1-2 (evenly)	200,000
Operation and maintenance ^b	Annually	150,000
Treatment		
Land	1	2,000
Fencing	3	10,000
Engineering design	3	15,000
Treatment works	3-5 (evenly)	900,000
Operation and maintenance ^b	Annually	100,000

a. Includes mechanical and electrical installation.

b. Calculated assuming full capacity, beginning in year 11. (Because of initially incomplete capacity utilization, the costs upon completion of the system in year 5 would be 50 percent of the costs listed, increasing over years 6-10 to the full amounts shown.)

twice). All these costs must be shadow priced, and it is thus necessary to determine separately the costs of unskilled labor and imported items. These capital costs are then converted to annual costs by multiplying by the appropriate CRF as described in the previous example.

Annual operation and maintenance costs are then calculated, using the AIC of water for the unit cost of the flushing water necessary.

COLLECTION AND TREATMENT COSTS. These include all material and installation (labor) costs for the sewer network and its appurtenances (such as manholes and pumping stations) and for the treatment works (including land costs). Capital costs for collection and treatment should be calculated separately because they may be incurred at different times during the construction period and may also have different design lifetimes.

Example

Household costs are excluded from the example since they are calculated in the same way as those of the pit latrine. Note that the design lifetime of the household components is not likely to be the same as those of the collection system and treatment works.

Assume that the collection network and treatment works are constructed over a five-year period. Assume further that the shadowed costs are as listed (and incurred in the years stated) in table 4-2.

Assume also that: the design population is 250,000; the wastewater flow is 200 liters per capita daily; 50 percent of the design population is served upon completion of construction, increasing linearly to full utilization by the beginning of the eleventh year from

Table 4-3. *Costs (in Constant Base-year Prices) and Wastewater Flows for Conventional Sewerage Scheme (UNC)*

Year	Collection		Treatment		Wastewater flow (thousands of cubic meters)
	Capital	Operation and maintenance	Capital	Operation and maintenance	
1	900,000	0	2,000	0	0
2	900,000	0	0	0	0
3	800,000	0	325,000	0	0
4	800,000	0	300,000	0	0
5	1,200,000	0	300,000	0	0
6	0	75,000	0	50,000	9,125
7	0	82,000	0	55,000	10,038
8	0	90,000	0	60,000	10,950
9	0	97,500	0	65,000	11,863
10	0	105,000	0	70,000	12,775
11	0	112,500	0	75,000	13,688
12	0	120,000	0	80,000	14,600
13	0	127,000	0	85,000	15,513
14	0	135,000	0	90,000	16,425
15	0	142,500	0	95,000	17,338
16	0	150,000	0	100,000	18,250
17	0	150,000	0	100,000	18,250
.
.
.
44	0	150,000	0	100,000	18,250
45	0	150,000	0	100,000	18,250

Table 4-4. *Present Values (PV) of Costs (in Constant Base-year Prices) and Wastewater Flows for Conventional Sewerage Scheme (UNC)*

Year	Collection		Treatment		Wastewater flow (thousands of cubic meters)
	Capital	Operation and maintenance	Capital	Operation and maintenance	
1	900,000	0	2,000	0	0
2	803,571	0	0	0	0
3	637,755	0	259,088	0	0
4	569,424	0	213,534	0	0
5	762,621	0	190,655	0	0
6	0	42,557	0	28,371	5,177
7	0	41,543	0	27,864	5,085
8	0	40,711	0	27,140	4,953
9	0	39,378	0	26,252	4,791
10	0	37,864	0	25,242	4,606
11	0	36,221	0	24,147	4,407
12	0	34,497	0	22,998	4,197
13	0	32,597	0	21,817	3,981
14	0	30,938	0	20,625	3,764
15	0	29,158	0	19,438	3,547
16	0	27,404	0	18,269	3,334
17	0	24,468	0	16,312	2,976
.
.
.
44	0	1,147	0	764	139
45	0	1,024	0	682	124
Present value of column	3,673,371	612,689	665,277	408,702	74,575

Note: AIC (average incremental cost) = $(3,673,371 + 612,689 + 665,277 + 408,702)/74,575,000 = 0.07$ UNC per cubic meter of wastewater.

completion; the design lifetime of both the collection system and treatment works is forty years (measured from completion); and the opportunity cost of capital is 12 percent. Note that the costs given in table 4-2 are assumed to have been shadow priced already for unskilled labor and foreign exchange components. Operation and maintenance costs are assumed to vary with the population served, being 50 percent of the figures given upon completion, increasing to 100 percent of the figures by the beginning of the eleventh year from completion.

Given these assumptions, the costing procedure is:

- Construct a table, similar to table 4-3, in which all the costs incurred and the total volume (in cubic meters) of wastewater generated in each year are entered under the various headings as shown. The effect of inflation should be ignored in this calculation so that all costs are in constant prices.
- As shown in table 4-4, convert these costs and volumes to their present values (PV) by using a set of financial tables, a financial calculator, or the equation:

$$PV_t = \frac{C_t}{(1 + r)^{t-1}},$$

where C_t = cost incurred (or total wastewater volume produced) in year t ; and r = opportunity cost of capital in percent times 10^{-2} .

- Calculate the AIC of the collection and treatment components by adding together the sums of the PV of the capital and operation and maintenance costs for both components and then dividing by the sum of the PV of the wastewater volumes as shown in the last line of table 4-4. This gives the AIC of collection and treatment in UNC per cubic meter, from which the annual per capita AIC can be calculated because the per capita wastewater flow is known to be 200 liters per capita daily (73 cubic meters per year). In this example the AIC per cubic meter is 0.072 UNC, or 5.2 UNC per capita annually. The total AIC of the whole sewerage scheme in UNC per capita annually is then obtained by adding in the shadowed annual per capita household capital and operation and maintenance costs. This may be expressed in U.S. dollars by converting at the official exchange rate.

Note to Chapter 4

1. For a more detailed treatment of the issues in this chapter, see Kalbermatten, Julius, and Gunnerson (1982).

Part Two

Sanitation Program Planning

5

Comparison of Sanitation Technologies

A VARIETY of sanitation technologies exist. The principal ones are shown in figure 5-1. Those considered suitable for application in developing countries are described in chapters 8 through 22.

The most common approach to making comparisons of sanitation technologies is to define the comparative criteria and then use some kind of matrix that displays the putative performance of each alternative in relation to the stated criteria in the manner shown in table 5-1. The comparison is purely descriptive, and no overall ranking or conclusions are attempted. Table 5-1 is essentially a guide for nontechnical readers and a convenient summary for professionals. Its most useful function may be to exclude certain technologies in a given situation, rather than to select the best.

More complex approaches to matrix comparisons are possible. For example, each criterion may be weighted numerically and the degree to which each technology satisfies each criterion may be assigned a score on a numerical scale, so that weighted performance figures can be obtained for each technology, and the technologies ranked accordingly. This method of technology comparison, which is by implication a method of technology selection, has several major disadvantages. The ranking depends on the weightings given to the performance criteria, and these weightings contain a strong element of value judgment. The value judgments used are generally those of an "expert group," which does not represent the user population. A different panel of experts might well produce different results, and the community members themselves might not only assign different scores and weighting factors but would probably employ different criteria. Thus, ranking technologies in this way produces not only a numerical comparison of spurious precision, but one that may also be, to the users at least, irrelevant. Moreover, in any given community there are always basic physical and cultural attributes that, in conjunction

with the existing level of water supply service and the community's general socioeconomic status, limit the choice of technologies considerably, irrespective of the overall scores achieved in a numerical matrix comparison of all possible technologies. These factors and their influence on technology choice are discussed below.

Water Supply Service Levels

A readily available supply of water is quickly reflected in the amount used and, hence, in the options available for its disposal. It has been found that neighborhood standpipes ordinarily supply 20 to 25 liters per capita daily. When a yard tap is provided, water use increases to 50 liters per capita daily, and when water is supplied through a tap inside the house, water use becomes 50 to 100 liters per capita daily, which is about the limit for on-site disposal of sullage.

Hand-carried supplies

Clearly, ventilated improved pit (VIP) latrines, Reed Odorless Earth Closets (ROEC's), ventilated improved double-pit (VIDP) latrines, and double-vault composting (DVC) toilets are possible choices since they require no water, except for toilet hygiene. Equally, cistern-flush toilets with either conventional sewerage or septic tanks and soakaways are technically infeasible, as are sewerage pour-flush (PF) toilets, since insufficient flows would be generated. The principal problem is whether PF toilets and vault toilets (which also have a PF squatting slab) are feasible or not. Is sufficient PF water likely to be hand carried into the toilet? Experience with the difficulty of water seal maintenance in conventional aquaprivies (chapter 13) suggests not, but user perception of the need to flush PF toilets is likely to be very high (in

Figure 5-1. *Generic Classification of Sanitation Systems*

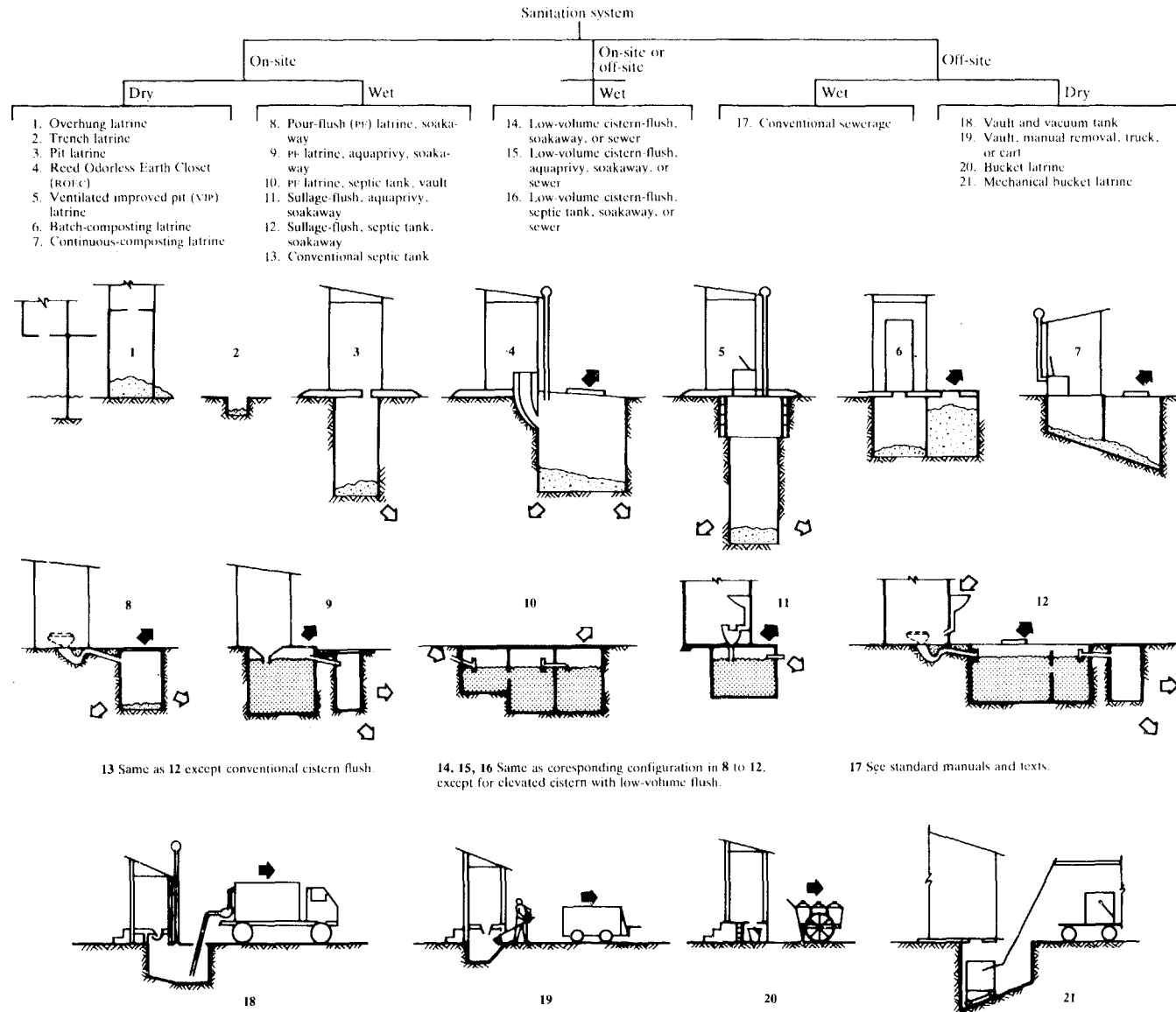

◊. Movement of liquids; ◆. movement of solids.

Source: The World Bank. *Water Supply and Waste Disposal*. Poverty and Basic Needs Series (Washington, D.C.: September 1980).

Table 5-1. *Descriptive Comparison of Sanitation Technologies*

Sanitation technology	Rural application	Urban application	Construction cost	Operating cost	Ease of construction	Self-help potential	Water requirement	Required soil conditions	Complementary off-site investment ^a	Reuse potential	Health benefits	Institutional requirements
Ventilated improved pit (VIP) latrines and Reed Odorless Earth Closets (ROECs)	Suitable	Suitable in L/M-density areas	L	L	Very easy except in wet or rocky ground	H	None	Stable permeable soil; groundwater at least 1 meter below surface ^b	None	L	Good	L
Pour-flush (PF) toilets	Suitable	Suitable in L/M-density areas	L	L	Easy	II	Water near toilet	Stable permeable soil; groundwater at least 1 meter below surface ^b	None	L	Very good	L
Double vault composting (DVC) toilets	Suitable	Suitable in L/M density areas	M	L	Very easy except in wet or rocky ground	H	None	None (can be built above ground)	None	H	Good	L
Self-topping aquaprivy	Suitable	Suitable in L/M-density areas	M	L	Requires some skilled labor	H	Water near toilet	Permeable soil; groundwater at least 1 meter below surface ^b	Treatment facilities for sludge	M	Very good	L
Septic tank	Suitable for rural institutions	Suitable in L/M-density areas	H	H	Requires some skilled labor	L	Water piped to house and toilet	Permeable soil; groundwater at least 1 meter below surface ^b	Off-site treatment facilities for sludge	M	Very good	L
Three-stage septic tanks	Suitable	Suitable in L/M-density areas	M	L	Requires some skilled labor	H	Water near toilet	Permeable soil; groundwater at least 1 meter below surface ^b	Treatment facilities for sludge	M	Very good	L
Vault toilets and cartage	Not suitable	Suitable	M	H	Requires some skilled labor	H (for vault construction)	Water near toilet	None (can be built above ground)	Treatment facilities for night soil	H	Very good	VH
Sewered PF toilets, septic tanks, aquaprivies	Not suitable	Suitable	H	M	Requires skilled engineer/builder	L	Water piped to house and toilet	None	Sewers and treatment facilities	H	Very good	H
Sewerage	Not suitable	Suitable	VH	H	Requires skilled engineer/builder	L	Water piped to house and toilet	None	Sewers and treatment facilities	II	Very good	H

Note: L, low; M, medium; H, high; VH, very high.

a. On- or off-site sullage disposal facilities are required for nonsewered technologies with water service levels in excess of 50 to 100 lcd, depending on population density.

b. If groundwater is less than 1 meter below the surface, a plinth can be built.

contrast, the water seal in an aquaprivy is almost invisible). The inconvenience of carrying PF water to the toilet might be considered by the users to outweigh the advantages PF toilets have over pit latrines, and a VIP latrine might well be preferred at least until the water supply is upgraded, when the latrine can also be upgraded to a PF toilet (chapter 7). On the other hand, if the PF or vault toilet is to be located inside the house, social aspirations for an "inside" toilet might outweigh the inconvenience of carrying the PF water. This discussion highlights the need to determine community preferences (chapter 3).

Yard taps

PF toilets and vault toilets are now possible choices, but not cistern-flush toilets. If sullage generation exceeds 50 liters per capita daily, sewered PF toilets also become technically feasible. Direct discharge to sewers is not advisable, however, because the small amount of water needed for a PF toilet is rarely sufficient to carry excreta the distance required. It is therefore preferable to connect the PF wall to a small settling tank (usually the existing soakage pit) and then to the sewer. The choice between these additional possibilities and VIP latrines, ROEC's, and DVC toilets (which are also still technically feasible) depends on other factors discussed later.

In-house connections

Cistern-flush toilets with conventional sewerage or septic tanks and soakaways are now technically feasible, and the decision of whether to install them is an economic and financial one. Communities that value the reuse of excreta and have successfully operated DVC toilets or three-stage septic tanks may be reluctant to abandon them and certainly should not be encouraged to do so.

Soil Conditions

Soil conditions are important for all sanitation technologies except those that can be completely contained above ground level. The only two technologies that fall into this category are DVC toilets and vault toilets, although in principle the three-stage septic tank and the conventional septic tank with a raised evapotranspiration bed for effluent disposal could also be classified as "above ground" technologies.

Soil stability is important for VIP latrines, ROEC's, and PF toilets. In unstable soils pits must be lined,

often to their bases. Soil permeability is important for these technologies as well, and also for septic tank soakaway trenches. In impermeable soils these technologies are infeasible. Sewerage may be affordable by those who could have afforded septic tanks, but often the only alternative is to provide vault toilets and separate sullage disposal facilities.

If the groundwater table is within 1 meter of the ground surface, VIP latrines, ROEC's, and PF toilets are of doubtful feasibility. They may be feasible if the soil is sufficiently permeable that the liquid level in the pit is not less than 0.5 meter below ground level, but the pit may be unstable unless supported to its base, and mosquito breeding is likely to be a problem (except in PF toilets). The structure may be set on a plinth or raised as shown in figure 10-4. For ROEC's and single-pit VIP's, which require large pits, pit excavation and lining are likely to be hazardous and very difficult.

The presence of rock near the ground surface creates difficulties for all technologies affected by soil conditions. It makes conventional sewerage even more expensive and PF systems with small-bore sewers comparatively more attractive, though still very costly. VIP latrines, ROEC's, and PF toilets become considerably more expensive, but the temptation to build pits with an effective life of less than two years should be strongly resisted. After two years another pit must be dug, but when it is filled the contents of the first may be safely removed because only a few viable *Ascaris* ova will remain after one year. Social repugnance at excavating excreta, even though excreta are a pathogen-free compost, may militate against these technologies and favor vault toilets, unless pit emptying is a municipal function.

Housing Density

In very densely populated urban areas, VIP latrines and ROEC's are infeasible, and PF toilets and septic tanks with soakaways are feasible only under exceptional circumstances. Conventional sewerage, sewered PF systems, and vault toilets are feasible. If site gradients are steep enough to provide self-cleansing velocities, PF toilets discharging directly to sewers without the wastes' first entering a settling tank are also feasible. The choice among these possibilities is decided essentially on economic grounds, although access for service vehicles and sullage disposal facilities is important for vault toilets (and the former also for desludging sewered PF settling tanks). It is unlikely that DVC toilets will be feasible because suf-

ficient biodegradable waste such as straw may not be available and, in any case, the community generally will not have a use for the compost and so will not be motivated to produce it.

It is not easy to define at what population density on-site systems such as VIP latrines, ROEC's, PF toilets, and DVC toilets become infeasible. The figure is probably most commonly around 250 to 300 persons per hectare, although it depends to some extent on the type of housing; feasibility at higher densities (up to around 500 to 600 persons per hectare) may often be possible if double-storied buildings are used: PF toilets may be feasible at even higher densities. The main point is to determine, in any given situation, whether or not there is sufficient space on the plot to provide two alternating pit sites that have a minimum lifetime of two years. Two years is the absolute minimum lifetime, as noted above, but the minimum desirable lifetime is five years, with ten years being preferred for VIP latrines and fifteen to twenty years for ROEC's. Even longer lifetimes are found in the Sudan, where pits some 25 meters deep are common. An advantage of ROEC's and PF toilets is that their pits, being completely offset, can be easily emptied so that it is not essential to provide two alternating pit sites. Pit contents less than one year old must be aged or treated before reuse. With alternating pits, one pit can be rested for sufficient time (at least one year) for complete pathogen destruction so that treatment is not necessary.

Costs

Clearly, all technologies should be least-cost solutions and must be affordable. The decision of which technology to select should be based on economic (rather than financial) costs since these represent the real resource cost to the national economy. Minimizing such cost is an economic goal of all countries. The technology with the lowest economic cost is generally the one that should be selected (although where two technologies have very similar economic costs, the choice may be largely a matter of judgment on nonquantified aspects). If the users are willing to pay the full economic cost of a more expensive technology (so that there is no need for subsidy), they should be free to select that technology. In such a case, the additional benefits perceived by the users of the more expensive technology outweigh its additional cost to them. An example of total annual economic (shadow-priced) costs per household of the different technologies may be obtained from table

5-2, which summarizes costs collected in 1977-78 by the World Bank.

The costs perceived by the municipality (or other implementing agency) and by the users are the financial costs that they will have to incur. Municipalities may be sophisticated enough to consider financial "life cycle" costs (in effect the present value of the costs to be incurred by the municipality itself; these distort the picture by excluding householders' costs and often the cost of flushing water), but more commonly both the institution and the individual are most concerned about the level of the capital and operating costs of the recommended program. "Lumpiness" of investment is as much a problem in sanitation as it is in conventional sewerage. Although a VIP latrine with a large pit and a permanent superstructure may be more economical over its ten-year life, it is not practical for the householder if its initial construction requires most of his cash income for months. (An exactly analogous situation occurs in water supply: poor families continue to depend on water vendors although, if they could once save up enough money, they could have a house connection and enjoy a far better service at lower cost.)

The objective of the financial feasibility study is to identify ways of making the alternative with the lowest economic cost affordable to the recipients. Initially, a very difficult judgment will have to be made on what proportion of their cash income householders are able and willing to devote to sanitation, and on the extent to which they can contribute their own labor and materials to reduce capital and operating costs. This may need to be decided through pilot studies, which may also be used to develop

Table 5-2. *Summary of Annual Economic Costs per Household*
(1978 U.S. dollars)

Sanitation technology	Cost		
	Mean	Highest	Lowest
Pit latrines, PF toilets, and ROEC's	28	56	8
DVC toilets	46	75	29
Vault and vacuum collection	104	210	26
Sewered aquaprivy or PF toilets	159	191	125
Flush toilets with septic tanks	233	390	35
Conventional sewerage	400	641	142

Note: Costs include annuitized capital and annual operating costs of on-site, collection, and treatment facilities, shadow priced as appropriate. Sewerage costs are average incremental costs (AIC's). The figures given in this table are taken from a limited number of observations (particularly in the cases of DVC and PF toilets and sewered aquaprivies); they should therefore be used only as an indication of relative costs, not as absolute values.

criteria for deciding on the levels of contribution to be required from participating households. This judgment, when compared with the estimated capital and operating costs of the program, will give guidance on how to arrange the program financing.

For example, if on the one hand the household contribution is equivalent to the annuitized financial cost of the system, then the alternative is affordable provided that some means can be found to even out the lumpiness of the investment. This may be done by the municipality lending the funds directly to the users, by the national government channeling funds through the implementing agency, or by any other means that can be devised to fit the circumstances. The point is that these funds can be in the form of loans, and in designing the program careful thought should be given to cost recovery mechanisms, the treatment of defaulters, and so on.

If, on the other hand, it is evident that the maximum likely household contribution will not meet the annuitized cost of even the cheapest technology, then there are only two choices: abandon the program in that particular area or find means of subsidizing it through other revenues. Subsidies should be generated within the community (if possible within the sector; for example, from water revenues) because it is the community that primarily benefits from the improved health of its poorest members. In many small towns in developing countries, however, the tax base is too weak to sustain any further burdens. In such cases the national government may be able to provide subsidies. Before doing so, however, it should carefully consider the opportunity cost of subsidies. Equity questions arise as well: for example, is it appropriate to use funds collected from the entire country to subsidize residents of a few cities? The sociopolitical goals of the national government often determine the financial feasibility of sanitation programs. For example, the government may wish to decide upon its total budget for sanitation improvements and distribute it so as to equalize per capita expenditures; alternatively, it may wish to spend it all in rural areas. In any case, continuing subsidies from outside the community for operation and maintenance costs are not advisable.

Other Factors

In addition to water service levels, soil characteristics, housing density, and system costs, several other factors enter into comparisons of sanitation technology.

Complementary investments

Sullage disposal facilities need to be considered for all technologies except sewerer PF toilets and cistern-flush toilets with conventional sewerage or septic tanks and soakaways in regions where water use exceeds, say, 50 liters per capita daily in medium- or high-density areas. Off-site night-soil or sewage treatment works are required for vault toilets, sewerer PF toilets, and conventional sewerage systems.

Reuse potential

DVC toilets should be provided only where there is a demand to reuse excreta. Material from latrines can be applied as fertilizer if the pits from which it is removed were not used for twelve months or more. Treated sludge from sewerer systems requiring periodic desludging, vault toilets, single-pit PF and VIP latrines, and conventional sewerage also can be used as fertilizer. Night soil and sludges can be digested to provide biogas (methane) as well as fertilizer. Before the predicted benefits from a reuse scheme are included in the economic assessment of a technology, however, the feasibility of the scheme must be thoroughly and realistically examined, especially in areas where the reuse of excreta is not a traditional practice.

Self-help potential

The unskilled labor and some (but not all) of the skilled labor required for VIP latrines, ROEC's, DVC and PF toilets, and three-stage septic tanks can be provided by the users. Self-help labor, however, requires organization and supervision by the local authority, especially in urban areas. Many of the labor requirements for the on-site portions of the other technologies can be provided by residents. Off-site construction requires experienced engineers and skilled builders for design and construction.

For the least-cost technology comparison, self-help labor should be shadow priced at the opportunity cost of unskilled labor during the season when the work will be done. In countries where unskilled labor is inexpensive, the reduction in economic costs achieved by the use of self-help labor may not be very great. The householders' involvement in construction, however, may be psychologically advantageous: subsequent toilet maintenance is likely to be of a higher standard because its need and how to do it may be more readily perceived.

Anal cleansing material

PF and cistern-flush toilets cannot easily dispose of anal cleansing materials such as maize cobs, stones, and cement-bag paper because these materials can clog the water seal. Aquaprivies (and latrines with mechanical seals) are better able than PF toilets to process these materials, but at greater cost and at higher risk of system malfunction (see chapter 12). Many communities, however, have a traditional practice of not disposing of their anal cleansing materials in the toilet; for example, the Ashanti people in central Ghana place paper and maize cobs on the ground surface near traditional unimproved pit latrines, and in many parts of Brazil even conventional toilet paper is placed in small bins adjacent to cistern-flush toilets. In some communities in Zambia, used cleansing material is placed in metal cans rather than being flushed into sewerage aquaprivies because comparatively recent experience has shown the users that blockages otherwise happen. Clearly, these various means of disposal can present serious health hazards and require attention when the public hygiene program is being designed. The practice of using water for anal cleansing presents problems for DVC toilets, which may become too wet for efficient composting.

Environmental Factors Affecting Choice of Technology

Information on the natural physical environment of an area will often enable one to exclude certain options. Kalbermatten, Julius, and Gunnerson (1982) have included descriptions of environmental variables and their effects in their study (maps 1-19). Winter temperatures affect performance of waste treatment ponds, digesters, and biogas units because each decrease of about 10° Celsius (C), or 18° Fahrenheit (F), has the effect of decreasing biochemical reaction rates by about half. The magnitude and rate of precipitation affects the general levels of flooding, runoff, water table, and plant growth. Aridity indexes show the ratios of potential evaporation to precipitation and indicate climatic zones, particularly those subject to desertification, where recovery of water, fertilizer, and energy from wastes is most im-

portant. Soil types reflect long-term effects of climate, and potential productivity is a measure of land or aquatic plant growth. Soil and weather yield higher productivity in the tropics, where rapid cycling of material through the biosphere is a major element in efficiencies of waste treatment ponds. Distributions of many excreta-related diseases show the environmental influence of the tropics (the limits of disease spread are based on reported cases where absence may be due to the absence of the disease itself or of specialists who can recognize it).

In contrast to the regional or global environmental influences, local changes in land use are often the limiting factor, especially in urban areas. For example, sewerage communal latrines would occupy up to 3 percent of total land area where population densities are about 1,000 persons per hectare and up to 10 percent if shower and laundry facilities are provided (not including space for clotheslines). Other schemes may require even greater percentages of the available space.

Institutional Constraints

Sanitation technologies may not operate satisfactorily, even if they are properly designed, because of lack of adequate maintenance (at the user or municipal levels), since the users and some municipal officials may not be fully aware of the need for maintenance or may lack the funds or know-how to provide it. Thus, user education and institutional development programs will generally form an essential part of sanitation program planning. Often major changes are needed in a community's attitude toward excreta disposal and environmental sanitation generally, and major alterations to the existing municipal structure are often required. These changes, especially those in social attitudes, can be accomplished only slowly, which emphasizes the need for a planned series of incremental sanitation improvements over time (see chapters 1 and 20). In addition, pricing policies for communal sanitation systems must provide adequate funds for maintenance expenses. If community members are able but not willing to pay the necessary rates on a continuing basis, the system should not be built.

6

Selection of Sanitation Technologies

ONCE DIFFERENT SANITATION technologies have been compared on a technical basis, the sanitation program planner must select from those available the one most appropriate to the needs and resources of the community. This selection, which should be based on a combination of economic, technical, and social criteria, essentially reduces to the question of which is the cheapest, technically feasible technology that the users can afford, maintain, and prefer to cheaper alternatives and that the local authority is institutionally capable of operating. The critical items of information needed for selection and design of sanitation systems are indicated in table 6-1 (p. 50).

Selection Algorithms

Figures 6-1, 6-2, and 6-3 present stages of an algorithm that can be used as a guide to the selection of the most appropriate sanitation technology for any given community in a developing country. It should be stressed that the algorithm is meant only as a guide to the decisionmaking process. Its main virtue is that it prompts engineers and planners to ask the right sort of questions, which perhaps they would not otherwise ask; some answers can only be obtained from the intended beneficiaries (see chapter 3). Although it is believed that the algorithm is directly applicable to most situations encountered in developing countries, there will always be combinations of circumstances for which the most appropriate option is not the one suggested. The algorithm, therefore, should not be used blindly in place of engineering judgment, but as a tool to facilitate the critical appraisal of the various sanitation options, especially those for the urban and rural poor.

The algorithm is most useful when there are no existing sanitation systems other than communal facilities in the community under consideration. In gen-

eral, the existing household sanitation systems will influence the technology chosen to improve excreta and sullage disposal. In addition, it is important to consider the existing or planned sanitation facilities in neighboring areas. In this context and in the algorithm, affordability is taken to embrace both economic and financial affordability at the household, municipal, and national levels, including the question of subsidies. In any event, the environmental and other information listed in table 6-1 is essential to the algorithm.

The algorithm commences in figure 6-1 by asking if there is (or is likely to be in the near future) an in-house level of water supply service to the houses under consideration. This is the crucial question because its answer immediately determines whether cistern-flush toilets can be considered. If the houses do have piped water, if there is a strong social desire for cistern-flush toilets, and if they can be afforded, the main engineering problems are how to dispose of wastewater from the toilet ("black water") and from the kitchen, laundry, and bath (sullage or "graywater"). Septic tanks of either the conventional kind or of the design described in chapter 12 are preferable to conventional sewerage where they are cheaper, but their technical feasibility depends on the availability and suitability of land for soakaways and, in medium-density areas especially, on whether water use can be reduced to permit ground disposal of the effluent. If septic tanks are inappropriate, conventional sewerage can be used, provided that it is affordable and that there are no strong environmental reasons to oppose it. If neither septic tanks nor conventional sewerage is affordable, or if the community does not have in-house water supply service, then cistern-flush toilets cannot be used. The community may have a single yard tap supply or it may rely on hand-carried water from either public standpipes or water vendors. In any case, an essential question is whether there is sufficient water to flush

Figure 6-1. First-stage Algorithm for Selection of Sanitation Technology

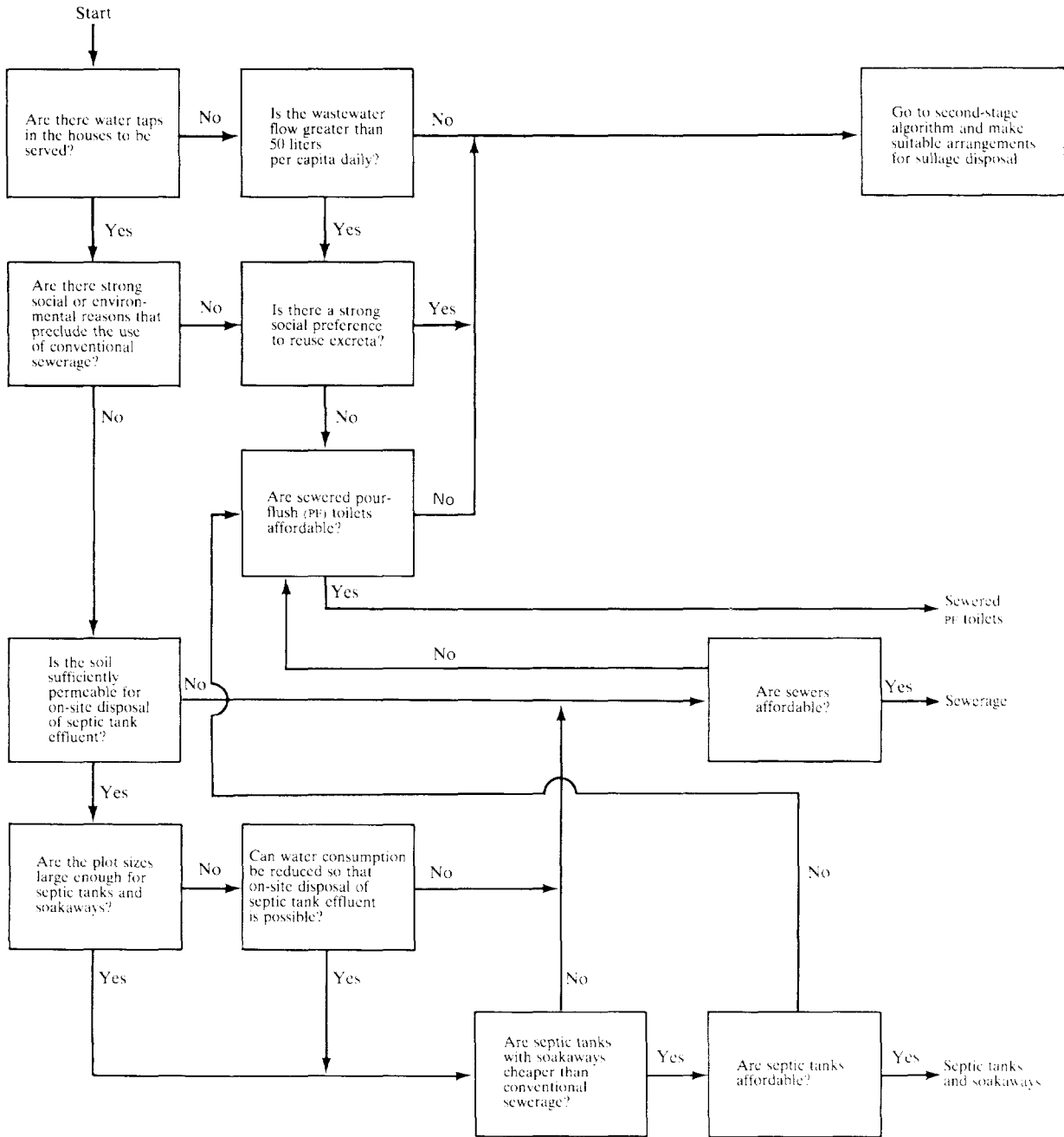

the sewers as well as the toilets. If the wastewater (sullage plus flushwater) flow is greater than 50 liters per capita daily, then a sewerer PF system can be used, provided it is affordable and there is no social preference for night soil to be collected separately for reuse.

If the quantity of water available is not sufficient for several systems, the choice lies between the various on-site excreta disposal technologies, with appropriate facilities provided for the disposal of sullage (see chapter 20). The algorithm recommences in figure 6-2 by asking if household reuse of excreta

Figure 6-2. Second-stage Algorithm for Selection of Sanitation Technology

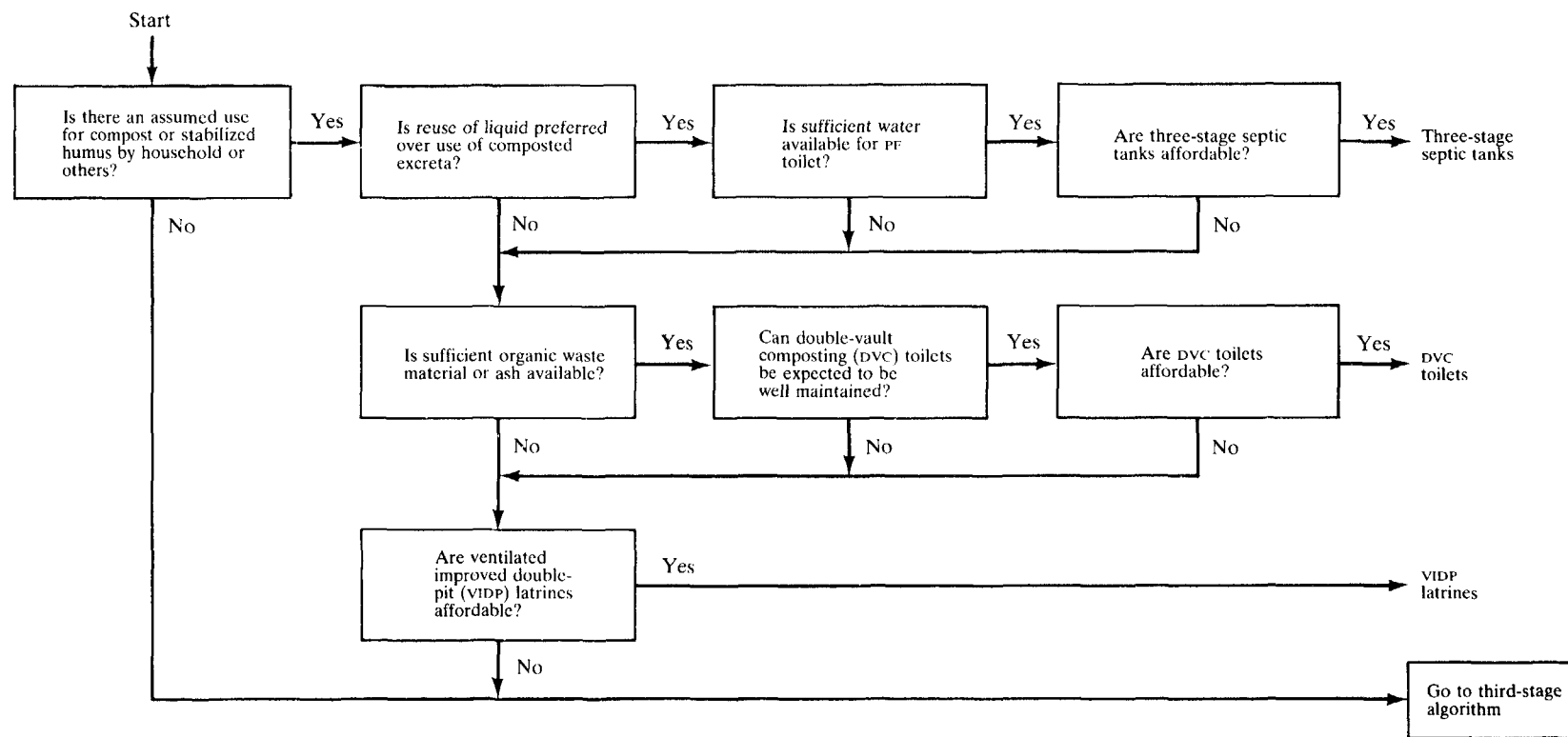

Figure 6-3. Third-stage Algorithm for Selection of Sanitation Technology

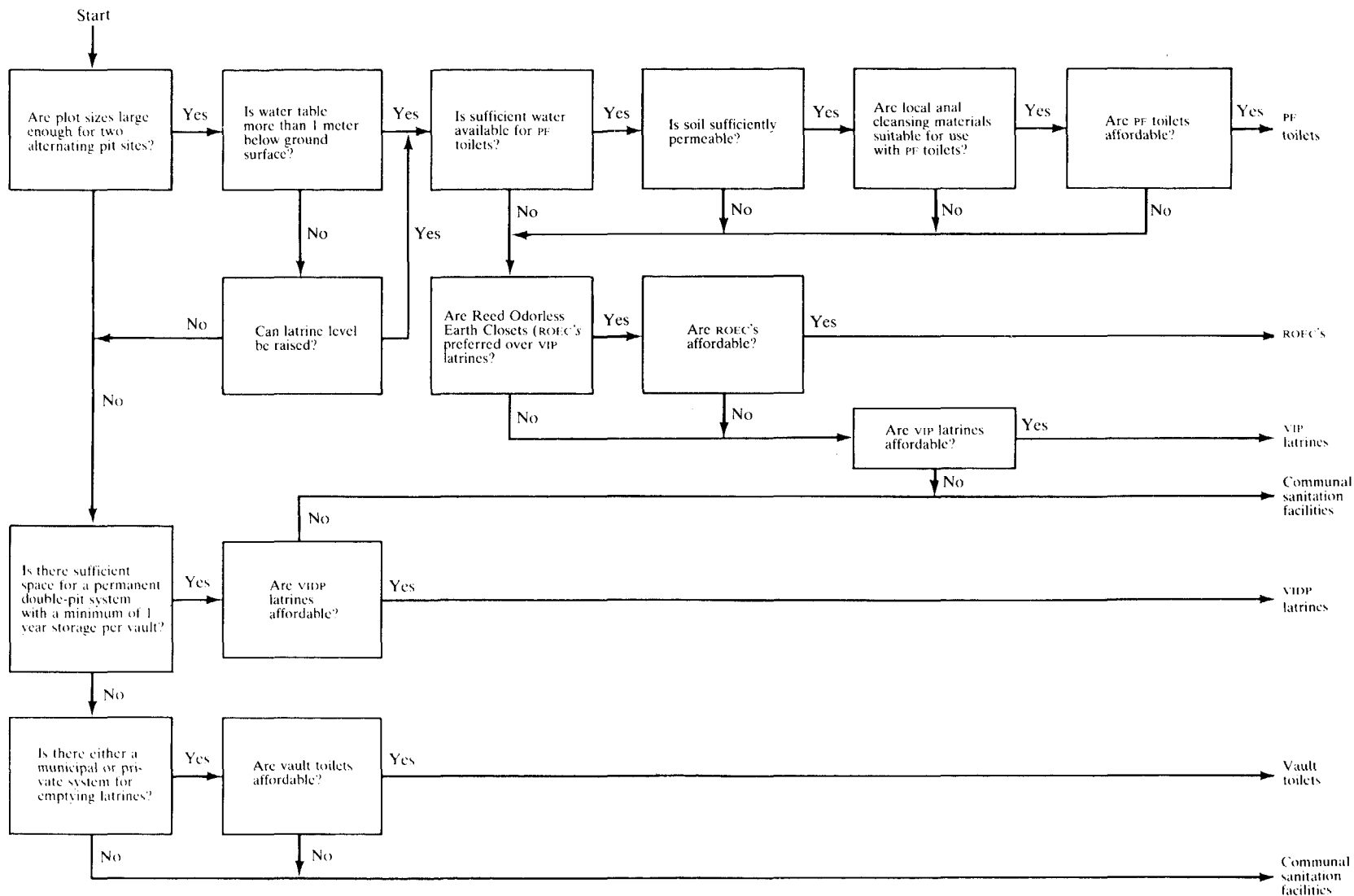

Table 6-1. *Critical Information Needed for Selection and Design of Sanitation Systems*

<i>Item</i>	<i>Description</i>
Climatic conditions	Temperature ranges Precipitation (including drought or flood periods)
Site conditions	Topography Geology (including soil stability) Hydrogeology (including seasonal water table fluctuations) Vulnerability to flooding
Population	Number (present and projected) Density (including growth patterns) Housing types (including occupancy rates and tenure patterns) Health status (of all age groups) Income levels Locally available skills (managerial and technical) Locally available materials and components Municipal services available (including roads, power)
Environmental sanitation	Existing water supply service levels (including accessibility, reliability, and costs) Marginal costs of water supply improvements Existing facilities for excreta disposal, sullage removal, and storm drainage Other environmental problems (such as garbage or animal wastes)
Sociocultural factors	People's perceptions of present situation, interest in or susceptibility to change Reasons for acceptance or rejection of any previous upgrading attempts Level of hygiene education Religious or cultural factors affecting hygiene practices and technology choice Location or use of facilities by both sexes and all age groups Attitudes toward resource reclamation Attitudes toward communal or shared facilities
Institutional framework	Allocation of responsibility; effectiveness of state, local, or municipal institutions in providing water, sewerage, sanitation, street cleaning, drainage, health and education services, housing and urban upgrading

Note: The priority given various items will vary with the sanitation options being considered; the list above indicates typical areas to be investigated by planners and designers.

is socially acceptable. If it is, then the choice is between three-stage septic tanks and DVC toilets. Reuse of liquid excreta from three-stage septic tank systems is appropriate for rural areas only, whereas DVC toilets are suitable for urban areas as well, provided that there is space for them and that the users are

able and willing to reuse the compost in their own gardens or are able to give or sell it to local farmers. DVC toilets also require a sufficient and continuous supply of organic waste materials such as straw and a very high level of user care, which often can only be achieved by a vigorous and sustained program of user education (the cost of which must be included in the total cost of the system). If all these conditions can be met and if the cost is lower than those of the alternative on-site disposal technologies, then either a three-stage septic tank or a DVC toilet is recommended, as determined by the algorithm.

If DVC toilets and the three-stage septic tank system cannot be used, the choice lies among VIP latrines, VIDP latrines, ROEC's, PF toilets, vault toilets, and communal sanitation blocks as determined by the algorithm in figure 6-3. If there is space enough for two alternating pit sites and if the groundwater table is at least 1 meter below the ground surface, then the recommended choice is either VIP latrines, VIDP latrines, ROEC's, or, if there is sufficient water and if the soil is sufficiently permeable, PF toilets. Since the costs of these systems are very similar, the choice among them should be left to the community. There may often be a strong social preference for PF toilets because these can be located inside the house. PF toilets require water to be hand carried to and, for user convenience, to be stored in the toilet. This may be difficult in houses dependent on public standpipes or water vendors and is an essential point to discuss with the community or their representatives. In houses with yard taps, a simple upgrading procedure, which can be done by individual householders (but under municipal control), is to pipe water into the toilet compartment.

In those urban areas where VIP latrines, ROEC's, and unsewered PF toilets cannot be used, the choice is between vault toilets and communal facilities. Household vaults are preferable to communal facilities, but they are more expensive and require access for collection vehicles, which the municipality must be capable of maintaining. In some very high-density areas there may not be access for even the smallest collection vehicles. In such areas either communal sanitation facilities are necessary or the vaults must be emptied by manually operated pumps; the community may prefer vaults so emptied because the vault toilet is an in-house facility that has good potential for upgrading to a seweried PF system (see chapter 7). There are, however, some high-density and low-income urban areas, such as those built on tidal mud flats, for which a seweried PF system will always remain unaffordable, although it may be tech-

nically feasible, and a communal facility is the only realistic sanitation improvement. Further improvement will generally be extremely difficult and often impossible both technically and economically unless it forms part of an urban renewal scheme involving overall housing improvements.

Postselection Questions

Once a tentative selection of the most appropriate technology has been made, several questions should again be asked as checks:

- Is the technology socially acceptable? Is it compatible with cultural and religious requirements? Can it be maintained by the user and, if appropriate, by the municipality? Are municipal support services (for example, education, inspection) required? Can these be made available?
- Is the technology politically acceptable?
- Are the beneficiaries willing (and able) to pay the full cost of the proposed facility? If not, are user subsidies (direct grants or "soft" loans) available? Is foreign exchange required? If so, is it available?
- What are the potential upgrading sequences (see chapter 7)? What time frame is involved? Is it compatible with current housing and water development plans? Are more costly technologies in the upgrading sequence affordable now?
- What facilities exist to produce the hardware required for the technology? If lacking, can they be developed? Are the necessary raw materials locally available? Can self-help labor be used? Are training programs required?
- Can the existing sanitation system, if any, be upgraded in any better way than that shown in the algorithm?
- Is there a neighboring area whose existing or planned sanitation system makes a more costly alternative feasible (for example, small sewers discharging to an existing sewer system)?
- What is the potential for reuse? If low, would the adoption of a technology with a higher reuse potential be economically justifiable?
- If the selected technology cannot process sullage, what facilities for sullage disposal are required (see chapter 20)? Is the amount of sullage low enough, or could it be reduced sufficiently to preclude the need for off-site sullage disposal facilities?

7

Sanitation Upgrading Sequences

THE SELECTION of the technology best suited to effect initial improvements in sanitation should also reflect the future need for incremental improvements as the users' aspirations and socioeconomic status rise. This chapter examines the feasibility of sanitation upgrading sequences with particular reference to incremental improvements in the level of water supply service (which is, of course, a measure of socioeconomic status). Representative upgrading sequences are summarized in figure 7-1 and are described below. Upgrading is optional and should be done only if users' demand and ability to pay for additional investments exists or if environmental conditions (increased population density, and the like) require it.

Composting Toilets

Consider the DVC toilet in a rural village where water is obtained from surface sources or wells and must be hand drawn and carried. Provided that the toilet functions well and is properly operated and that the demand for compost continues, there is no need to upgrade the toilet. Upgrading of the water supply from hand carrying to household hand pumps or reticulated yard taps, and thence to a fully reticulated system with multiple house connections, would likely be given priority over improvements in excreta disposal.

If the demand for compost should fall (perhaps because of increased housing density that necessitates fewer gardens or the introduction of subsidized chemical fertilizer distribution) or the toilet does not function properly (perhaps because of a sudden or a gradual unavailability of ash or suitable organic waste material), then it would be necessary to alter (rather than upgrade) the toilet; the most appropriate replacement technology will normally be the VIDP latrine, which would not require a change in

anal cleansing materials, or the PF toilet and thence, eventually, a sewerred PF system. The user may also wish to make this upgrading of his facility by personal choice rather than by being forced to do so by changing conditions.

Three-Stage Septic Tanks

This version of the septic tank is suitable where PF toilets are installed and excreta reused as fertilizer in liquid form (as in many rural areas of China, for example). Upgrading would apply only to water supply service level, as described above. It is important that sullage should not enter the septic tank because the excreta would then become too dilute for economic cartage to the farm, and the retention time in the tank would become too short for the required level of pathogen destruction.

If demand for the stabilized liquid excreta (slurry) to be reused as fertilizer falls, it is necessary to alter the technology rather than upgrade it, although (as in the case of the DVC) the user may elect to do this as a personal choice. The easiest modification in rural areas is subsurface percolation in a septic tank drainfield; sullage may then be added to the third compartment, as described in chapter 14.

Vault Toilets

The vault toilet and vacuum-truck system is most commonly used in urban areas, requires less space than any other system, and provides for reclamation of energy (as methane, or biogas) and fertilizers. Because the vault satisfactorily stores excreta and any PF water, no upgrading is necessary from the point of view of *excreta* disposal. Once the water supply service improves to the multiple tap level, however, it may be considered desirable to provide

Figure 7-1. Potential Sanitation Sequences

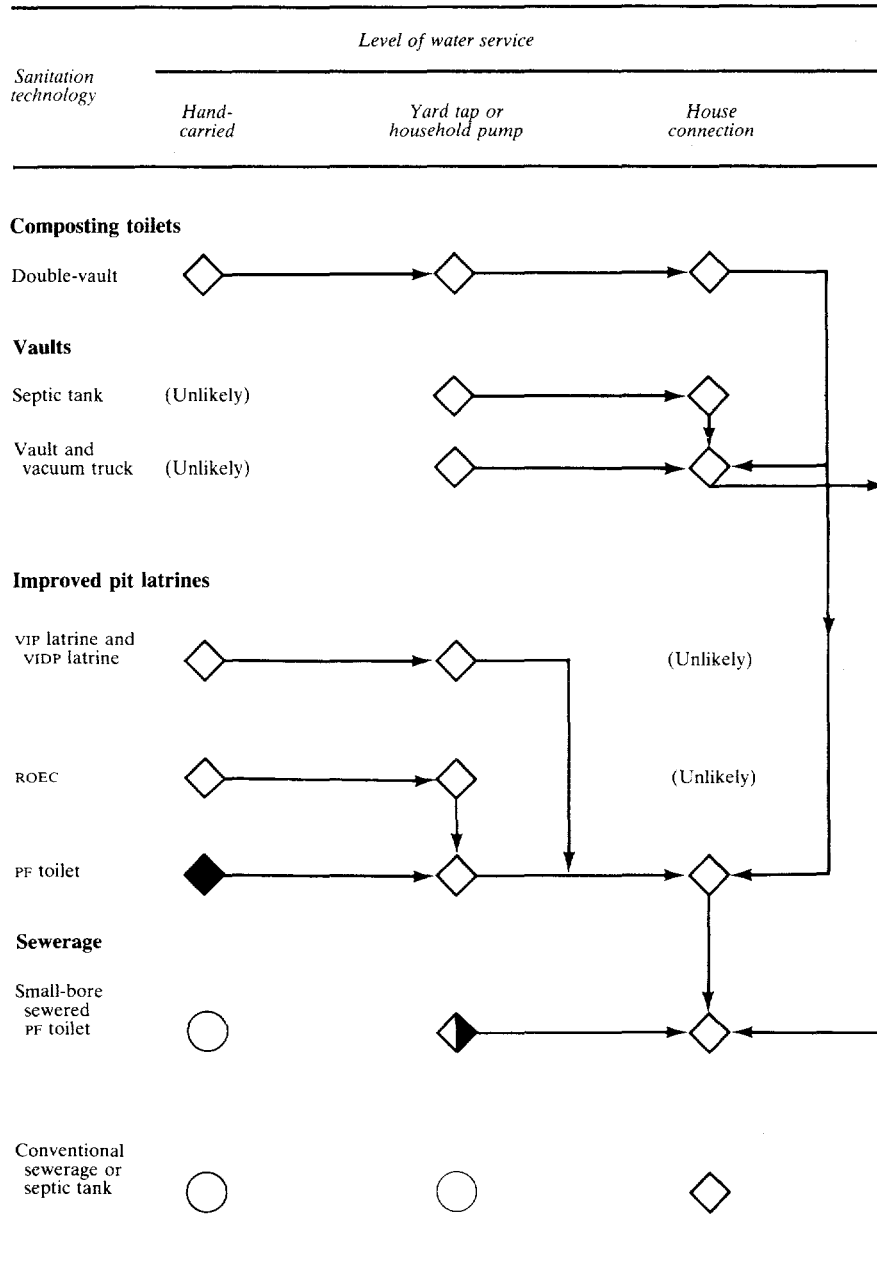

- ◇ Technically feasible.
- ◆ Feasible if sufficient pour-flush water will be hand carried.
- Technically infeasible.
- ◆ Feasible if total wastewater flow exceeds 50 liters per capita daily.

Figure 7-2. *Sample Sanitation Sequences*
(costs in 1978 U.S. dollars)

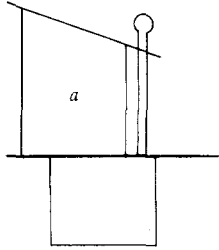
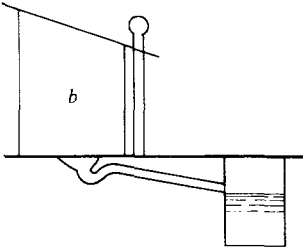
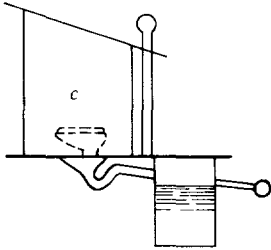
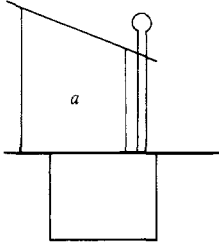
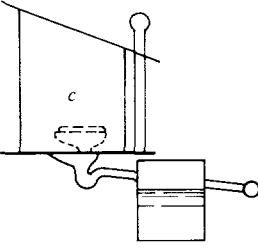
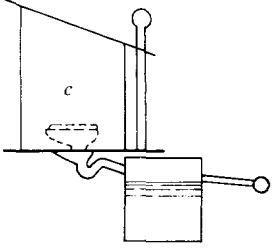
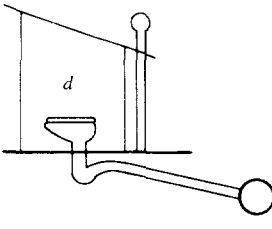
Item	Year 1	Year 10	Year 20 / Year 30	Total present value economic cost per household over 30-year period
<i>Scheme 1</i>				
Construction cost	108	65	905	354
<i>Scheme 2</i>				
Construction cost	108	915		1,111
<i>Scheme 3</i>				
Construction cost		960		1,519
<i>Scheme 4</i>				
Construction cost	978			3,000

- a VIP latrine.
- b PF toilet with soakaway.
- c PF toilet with small-bore sewer (with optional bowl and seat).
- d Conventional sewerage.

drainage systems for *sullage* disposal. If sewers are installed, the vault toilet may be converted to a sewered PF toilet, as described in chapter 6, by the addition of a small sullage tank adjacent and connected to the vault that discharges both settled sullage and settled excreta into small-bore sewers.

VIP Latrines and ROEC's

Many rural and suburban water and sanitation projects plan to provide pit latrines and communal hand pumps or public standpipes as the initial improvement. The pit latrine should be either a VIP latrine or ROEC (as described in chapter 10). The subsequent priority for improvement would most likely be upgrading the water supply to yard taps (or household hand pumps where applicable). Both the VIP latrines and ROEC's could then be upgraded to PF toilets. The conversion of a ROEC to a PF toilet is very simple and inexpensive: a water-seal squatting plate or pedestal seat (see chapter 12) is installed in place of the ROEC chute, and the existing displaced pit used to receive the toilet wastewater. Depending on soil conditions, it may be necessary to add a soakage pit to provide more infiltration area for the toilet flushwater; alternatively, an infiltration trench could be provided.

A VIP latrine can also be readily converted to a PF toilet by filling in the pit with soil and installing a water-seal unit that is connected by a short length of pipe to a newly dug pit. Clearly, this is best done when the pit is close to the end of its life and is most advantageous where the superstructure is not easily dismantled (for example, if it were constructed in concrete blockwork). With both VIP latrines and ROEC's it is helpful if the original design permits easy removal of the squatting plate to facilitate its replacement by a water-seal unit.

In many areas, especially where water is used for anal cleansing, users prefer a PF toilet even though water has to be carried to the house. In such areas a water storage vessel should be provided near the toilet.

PF Toilets

When the water supply is upgraded to the multiple tap level, it is possible to install a low-volume cistern-flush toilet. This is not essential and may not be considered a priority by the users, to whom upgrading of the water supply from a single yard tap to multiple in-house connections usually first means plumbed kitchens and bathrooms.

As discussed above for vault toilets, the main sanitation improvement is better disposal of sullage by surface drains or sewers. If sewers are to be used, they can also receive the settled flushwater from the original PF pit. The conversion operation is as follows:

- Build a small single-chamber septic tank close to the existing PF pit and discharge all the sullage directly into it (the tank should provide a twelve-hour retention time, subject to a minimum working volume of 0.5 cubic meter).
- Connect the existing PF pit to the sullage tank with 100-millimeter-diameter pipe (the pit outlet "T" junction should be located as near the top of the pit as technically feasible).
- Connect the sullage tank to the street sewer (the invert of the tank outlet should be a nominal 30 millimeters *below* that of the inlet from the pit to prevent sullage from flowing into the pit).

If the existing pit has sufficient infiltration capacity there will be little or no flow from the pit to the sullage tank. This does not matter. But as the infiltration capacity falls, and especially if low-volume cistern-flush toilets are installed, the flow will increase, and the pit acts as a sealed or semisealed first compartment of the two-stage septic tank described in chapter 12 (see also chapter 14). It is essential that the sullage tank—the second compartment of the two-stage septic tank—is provided so that the small-bore sewers do not become blocked.

Sample Staged Solutions

To demonstrate the feasibility of using a staged sanitation system, a possible scheme with several variations is described, and comparative economic costs are presented. The scheme or its variations could be started at any stage and terminated at any stage, depending on the desires of the users. For simplicity it is assumed that each stage remains in service for ten years, when the next stage would be added. The schemes described could be varied substantially without adding greatly to the cost. For example, to a PF latrine a vault (with vacuum-truck emptying) could be added if housing density increases or the soil becomes clogged. Similarly, a composting toilet that already has a watertight vault could be converted into a vault toilet or PF privy with a vault.

As shown in figure 7-2 (scheme 1), the initial sanitation facility would consist of a VIP latrine with a

concrete squatting slab and concrete block superstructure. One such facility in an East African city is used as the basis for the costs shown. Its (unlined) pit is about 5.5 meters deep and 1 meter square, and the normal filling time is ten years. Its initial construction cost is \$108, of which the superstructure accounts for \$53.

In year 11 the community water system is upgraded from wells or standpipes to yard hydrants, and the dry latrine is converted to a PF latrine by digging a new soakage pit near the superstructure and replacing the old squatting plate with a bowl and inverted siphon. The old pit is filled in prior to placement of the new squatting plate. For estimating purposes it is assumed that the accumulated sludge would be removed from the new pit at five-year intervals and composted.² The cost of trucks and the land and equipment for the composting facility are therefore included in year 15, and the trucks are replaced at five-year intervals thereafter. The operating and maintenance costs incurred in years 11–20 also include the flushing water for the PF toilet, calculated as 10 liters per capita daily for six persons at \$0.35 per cubic meter.

In year 21 the third stage would begin, when the water service is upgraded to house connections and a large volume of sullage water has to be disposed of. At this point a new (lined) pit would be dug and the existing bowl and siphon would be connected to it. An overflow pipe would connect the pit to a newly constructed small-bore sewer system. This upgrading would permit the use of cistern-flush toilets if desired by the users. Annual collection of sludge would be required from the smaller vault, and two trickling filter plants would be constructed for treatment of the vault effluent.³ The combined flushing water and sullage flow from year 21 onwards is taken as 175 liters per capita daily.

Comparative economic costs, on a household basis, were prepared for this scheme and for three variations (schemes 2–4), including the alternative of proceeding immediately with the construction of a conventional sewerage system. At a discount rate of 8 percent, the present value (PV) of the total cost per household of the three-stage scheme 1 over a thirty-year period is \$354, which includes the salvage value of the sewerage system, assumed to have a forty-year life. The second variation is a two-stage scheme that moves directly from the VIP (installed in year 1) to small-bore sewers in year 11. The PV cost per household over thirty years is \$1,111, or more than three times that of the three-stage alternative. The third alternative is simply to install a small-bore sewerage

system in year 1. This would have a total PV cost of \$1,519 per household over thirty years. The final alternative, calculated in the same way and with data from the same city as the seweried PF for purposes of comparison, is the immediate construction of a conventional sewerage system. A five-year construction period is assumed and the facility is assumed to be two-thirds utilized at the end of the five years and fully utilized ten years after completion. Based on these assumptions, the PV cost per household over thirty years is \$3,000. This includes the cost of flushing water and all regular operating and maintenance costs (as do the costs of the other alternatives). It is nearly ten times as high as the cost of the first, three-stage scheme and almost twice that of the one-stage seweried PF alternative.

An alternative to this upgrading sequence would be to move from the VIP latrine to a vault with vacuum-truck collection in year 11. Based on costs from such a system in a city on the island of Taiwan, the total PV cost per household over thirty years would be \$334. If in year 21 it was decided to convert from vacuum collection to a small-bore sewer system (as described in the previous sequence) the total PV cost would increase to \$411 per household. These costs are summarized in table 7-1, where the figures in

Table 7-1. *Costs of Sample Sanitation Sequences*
(1978 U.S. dollars)

	<i>Sequence and construction cost</i>			<i>Total present value (PV) cost per household^a</i>
	<i>Year 1</i>	<i>Year 11</i>	<i>Year 21</i>	
1. VIP (108)		VC (293)		334
2. VIP (108)		VC (293)	SBS (907) ^b	411
3. VIP (108)		PF (73)	SBS (907) ^b	354
4. VIP (108)		SBS (907) ^b		1,111
5. SBS (960) ^b				1,519
6. CS (978) ^b				3,000

VIP, Ventilated improved pit latrine; VC, vault toilet with vacuum-truck collection; PF, pour-flush toilet; SBS, small-bore sewer; CS, conventional sewerage.

a. Includes annuitized construction costs and operating and maintenance costs for entire thirty-year period.

b. Total construction cost divided by design population. PV calculated on basis of average incremental cost (AIC), which takes into account gradual capacity utilization (see chapter 4).

parentheses (from left to right) represent construction costs in years 1, 11, and 21.

None of the upgrading sequences discussed above leads to conventional sewerage. This is not because conventional sewerage schemes should not be built (they are an excellent form of sanitation for those who have plenty of water and can afford the collection and increasingly expensive treatment systems), but because they are not necessary to provide the highest standard of sanitation. The seweraged PF system, which can include a low-volume cistern-flush toilet for added user convenience, is a sanitation system of equally high standard that has two important advantages over conventional sewerage: it is substantially cheaper, and it can be reached by staged improvement of several different sanitation technologies. Thus, sanitation program planners can confidently select one of these "baseline" technologies in the knowledge that, as socioeconomic status and sullage flows increase, it can be upgraded in alternative sequences of incremental improvements to a more technologically sophisticated final system. The important fact to remember is that sewers are required

to dispose of sullage, not excreta, and that the elimination or reduction of nonessential water use is thus the critical element in an economic solution to sanitation problems. Furthermore, the costs of sewage treatment are higher where sullage has been added to sewage. These costs are particularly significant in developing countries, where the increasing competition for investment funds often limits the amount of resources that can be allocated to the water and sanitation sector.

Notes to Chapter 7

1. Alternatively—especially where ground conditions make deep excavation difficult or expensive—two alternating pits may be constructed, and the squatting plate moved to the second pit after the first is filled. The full pit can be emptied after one year and eventually reused, and the excavated material could be used without further treatment.
2. In some communities, sludge may be buried rather than composted.
3. This option is chosen for illustrative purposes because of available cost data from the same East African city.

Part Three

Sanitation Technology Options

8

Latrine and Toilet Superstructures

THE FUNCTION of the toilet superstructure is to provide privacy and to protect the user and the toilet from the weather. Superstructure design requires assessment of whether separate facilities are required for men and women in the same household. Local customs and preferences often influence superstructure location, orientation, shape, construction material, design (for example, roof, window details), and size. Color may strongly influence a householder's use and maintenance of the facility. These details should be designed in consultation with the user. The technical design requirements of the superstructure are relatively straightforward and may be stated as follows:

- Size: The plan area should be at least 0.8 cubic meter to provide sufficient space and generally not more than 1.5 cubic meters. The roof height should be a minimum of 1.8 meters.
- Ventilation: There should be several openings at the top of the walls to dissipate odors and, in the case of VIP latrines and ROEC's, to provide the through draft required for functioning of the vent pipe. These openings should be about 75 to 100 millimeters by 150 to 200 millimeters in size; often it is convenient to leave an open space between the top of the door and the roof.
- The door: This should open outwards to minimize the internal floor area. In some societies, however, an outward opening door may be culturally unacceptable, and an open entrance with a "privacy wall" may be preferred. In either case it must be possible to fasten the door from the inside, and it may also be necessary to provide an external lock to prevent use by unauthorized persons. At its base the door should be just clear of the floor to provide complete privacy and to prevent rot of the bottom of the door planks.
- Lighting: Natural light should be available and

sufficient. The toilet should be sufficiently shaded, however, to discourage flies; this is particularly important in the case of VIP latrines and ROEC's.

- Walls and roof: These must be weatherproof, provide adequate privacy, exclude vermin, and be architecturally compatible in external appearance with the main house. In urban areas especially, an L-shaped wall in front of the door may be regarded by the community as desirable or essential for privacy.

A wide variety of materials may be used to construct the superstructure: for example, brick or concrete blocks, with tile, corrugated iron, or asbestos-cement roof; mud and wattle, bamboo, or palm thatch, with palm-thatch roof; ferrocement, sheet metal, or timber, with corrugated iron or asbestos-cement roof. Some alternatives are illustrated in figure 8-1. The choice depends on cost, availability of material, and community preferences. The important point is that designs meet the criteria in the list above. If the superstructure is for a VIP latrine or ROEC, it may not be a permanent structure but one that must be dismantled and erected again over or adjacent to the new pit. It should therefore be designed with this in mind, although this becomes of less economic importance as the design life of the pit increases.

Many communities, given the choice, choose inside toilets. Only PF and cistern-flush toilets are suitable for interior locations. If these are not to be provided initially, it may be sensible to design the house with a toilet compartment that can be fitted out at a later date as part of a sanitation upgrading program.

In figure 8-1, several low-cost, easily constructed superstructures are shown. A wide variety of options is available to the homeowner, only four of which are illustrated here. The choice of superstructure should reflect the user's personal preferences.

Figure 8-1. *Alternative Materials for Latrine Superstructures*

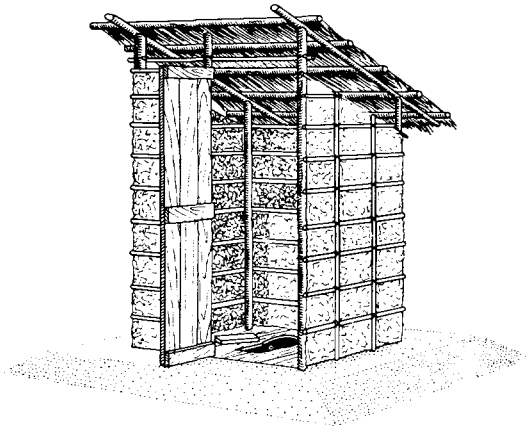

A. Mud and wattle walls and palm-thatch roof

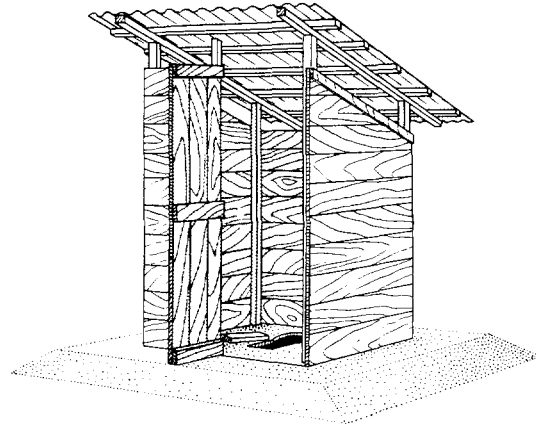

B. Timber walls and corrugated iron or asbestos-cement roof

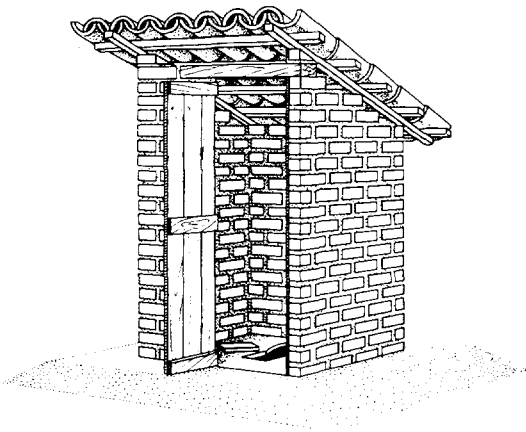

C. Brick walls and tile roof (an alternative is concrete block walls and corrugated iron or asbestos-cement roof)

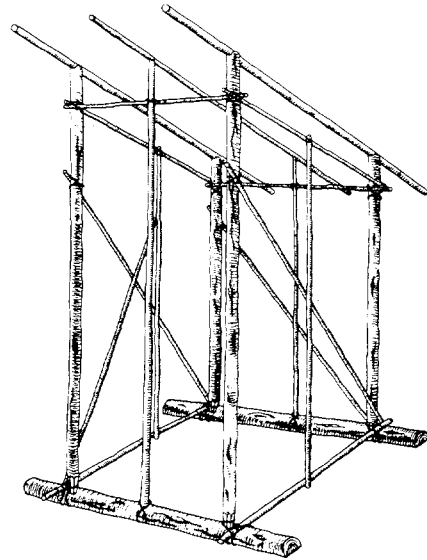

D. Rough-cut tree limbs and logs

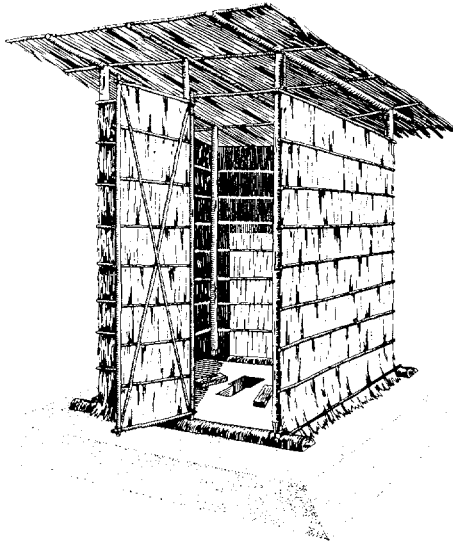

E. Palm-thatch wall and roof covering

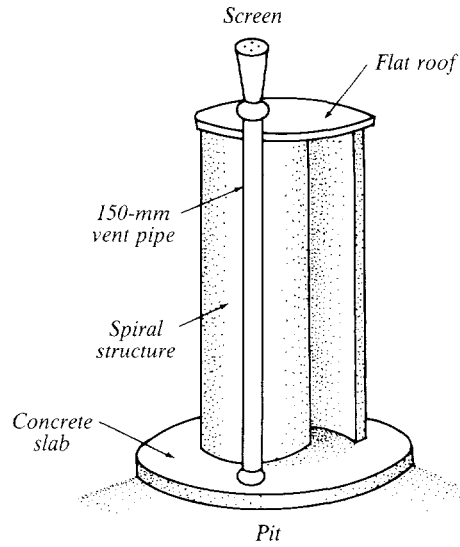

F. A ventilated pit privy

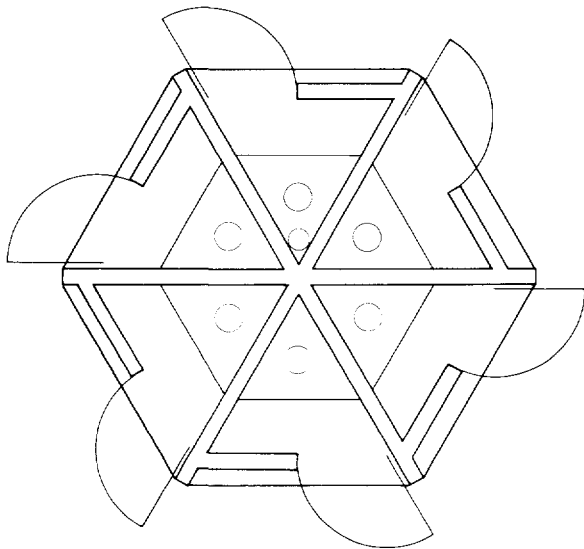

Plan

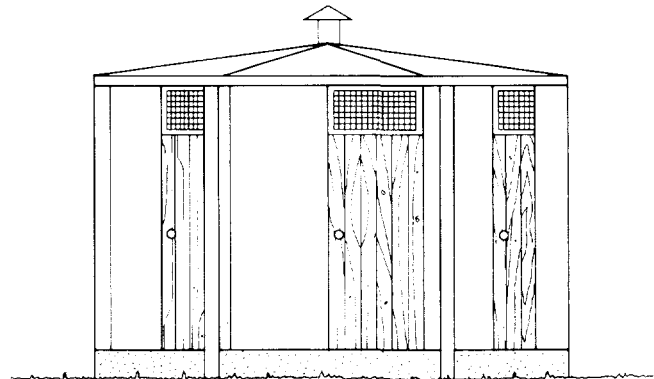

Elevation

G. Multiple-compartment pit latrine

Sources: For A–E, Wagner and Lanoix (1958); for F, *Appropriate Technology* (1979; © International Scholarly Book Services, Inc.: used by permission); G is adapted from a design used in Haiti by the Foundation for Cooperative Housing.

9

Latrine and Toilet Fixtures

A SUITABLE BASE or foundation for latrine or toilet fixtures is often included in the construction of the pit or other substructures. Alternatively, the base may be constructed separately of wood or integrally as part of the squatting plate.

It is essential to determine whether the local preference is to sit or squat during defecation. If the wrong facility is chosen, it will have to be converted at unnecessary expense; alternatively, it will remain unused or the superstructure will be used for other purposes such as grain storage. Anal cleansing practices and materials also need to be evaluated; flap-trap designs, conventional and VIP latrines, ROEC's (chapter 10), and aquaprivies can accept rocks, mud balls, maize cobs, and other bulky materials that would clog water seals.

Squatting Plates for VIP Latrines

Four important design considerations (for further details, see chapter 10) are:

- The opening should be about 400 millimeters long, to prevent soiling of the squatting plate, and at most 200 millimeters wide, so that children will not fall into the pit. A "keyhole" shape is suitable.
- Footrests should be provided as an integral part of the squatting plate and properly located so that excreta fall into the pit and not onto the squatting plate itself.
- The free distance from the back wall of the superstructure to the opening in the squatting plate should be in the range of 100 to 200 millimeters; if it is less there is insufficient space, and if it is more there is the danger that the rear part of the squatting plate will be soiled. In general, the preferred distance is 150 millimeters.
- The squatting plate should have no sharp edges

or rough surfaces that would make its cleaning difficult and unpleasant.

A variety of materials can be used to make the squatting plate: timber, reinforced concrete, ferrocement, and sulfur cement are usually the cheapest, but glass-reinforced plastic, high-density molded rubber, or PVC (polyvinyl chloride) and ceramics can also be used. Cost and aesthetics are the important criteria, apart from strength and rigidity. A variety of finishes can be applied to concrete or ferrocement squatting plates (for example, alkali-resistant gloss paint and polished marble chippings) or the concrete itself can be colored. Aesthetic considerations are often extremely important to the users and should never be ignored by engineers and planners; indeed, planners should make a special effort to determine community preferences before the final design stage.

Figure 9-1 shows a good design for a reinforced concrete squatting plate. A ferrocement version of this is possible and advantageous, since it need only be 18 to 25 millimeters thick, rather than 70 millimeters as shown, with consequent savings in materials and weight but with equal strength. The mix specification for ferrocement is: 1 part cement, 2 parts medium to coarse sand (sisal and coconut husk fibers have also been used as filler), and up to 0.4 parts water (the mix should be as dry as possible); reinforcement is provided by two layers of 12-millimeter-opening chicken wire across the slab. An alternative ferrocement design with an integral metal "flap-trap" has been developed in Tanzania (figure 9-2). The metal flap-trap is prefabricated from 1-millimeter-thick mild steel sheet and is then galvanized. It is not known how successful this design is, although a similar design made of aluminum has been successfully used in the Sudan. Figure 9-2 is included to demonstrate the feasibility of developing locally acceptable alternatives.

Figure 9-1. Concrete Squatting Plate
(millimeters)

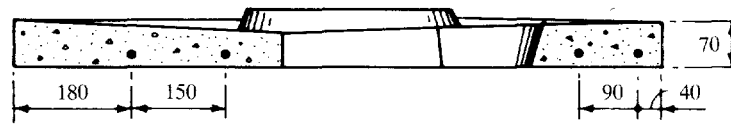
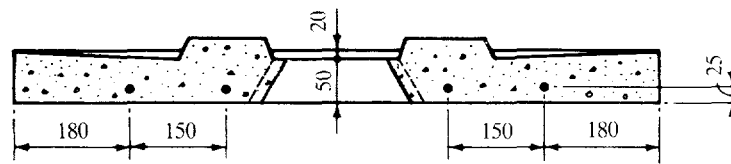
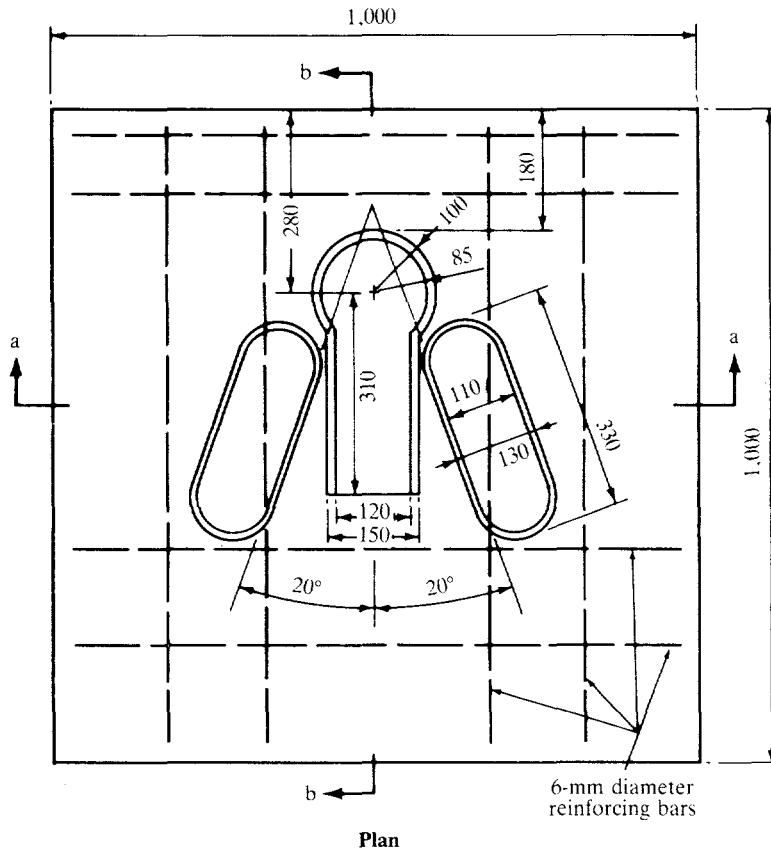

Source: Adapted from Wagner and Lanoix (1958).

Figure 9-2. Tanzanian "Flap-trap" Design for VIP Latrines and DVC Toilets (millimeters)

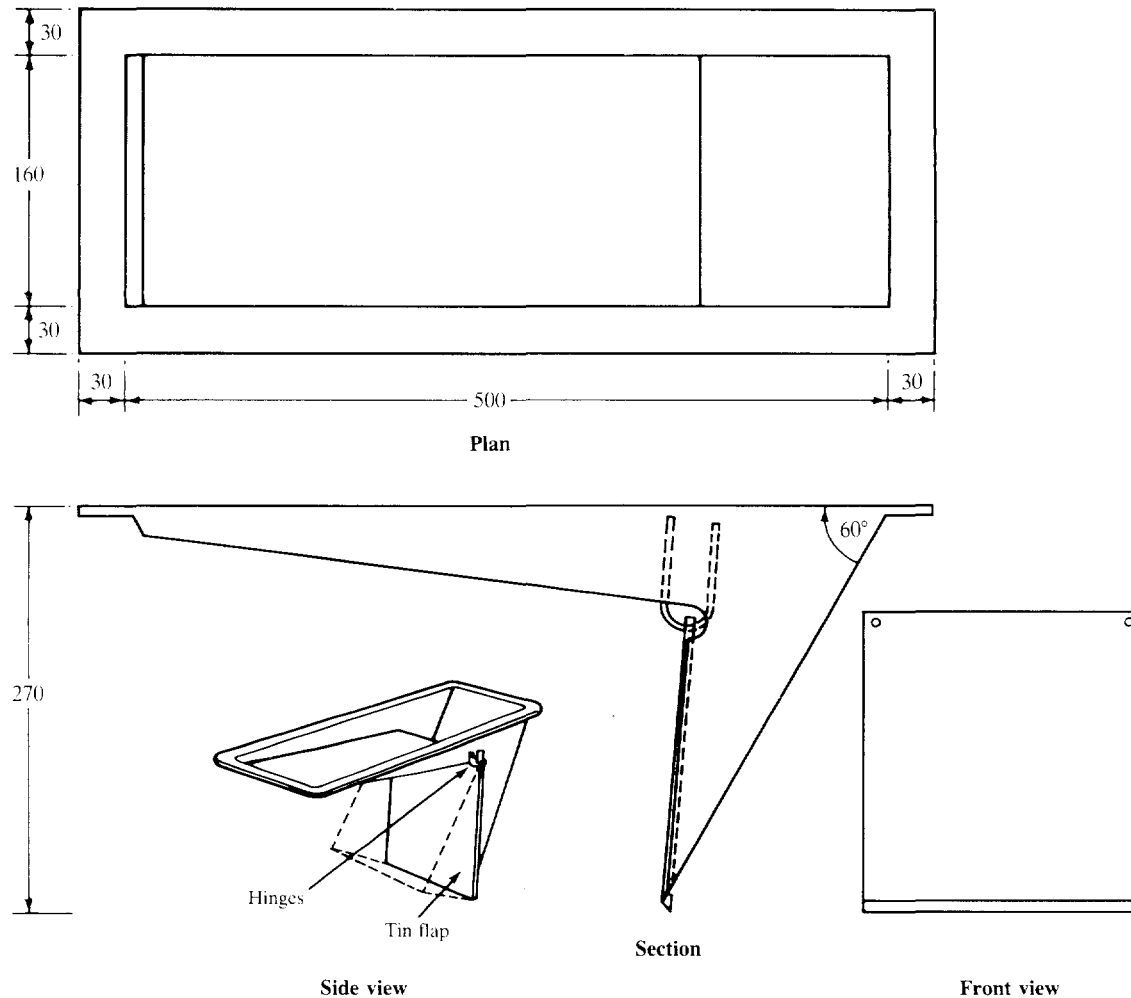

Note: It is suggested that the flap-trap be made of plastic.

Source: Adapted from a drawing by U. Winblad.

Squatting plates should be cast in an oiled timber mold for ease of construction. If the scale of manufacture is large, a steel mold may be preferable.

Squatting Plates for ROEC's

With ROEC's (for further details, see chapter 10) it is necessary to provide a steeply (60°) sloping chute to direct the excreta into the adjacent offset pit (figure 9-3). The chute diameter should be from 150 to 200 millimeters but should be enlarged under the squatting plate to attach around the entire squatting

plate opening. It is possible, but rather difficult, to cast the chute in ferrocement as an integral part of the squatting plate; in practice it is easier to use metal or PVC pipe cut to shape.

Pedestal Seats for VIP Latrines and ROEC's

The important design criteria (for further details, see chapter 10) are the seat height and the size of the opening. For adults a 250-millimeter diameter is normally suitable. The pedestal riser can be constructed in brick, concrete blockwork, or wood; in-

Figure 9-3. Pedestal Seats for Dry Latrines and Chute Designs for ROEC's

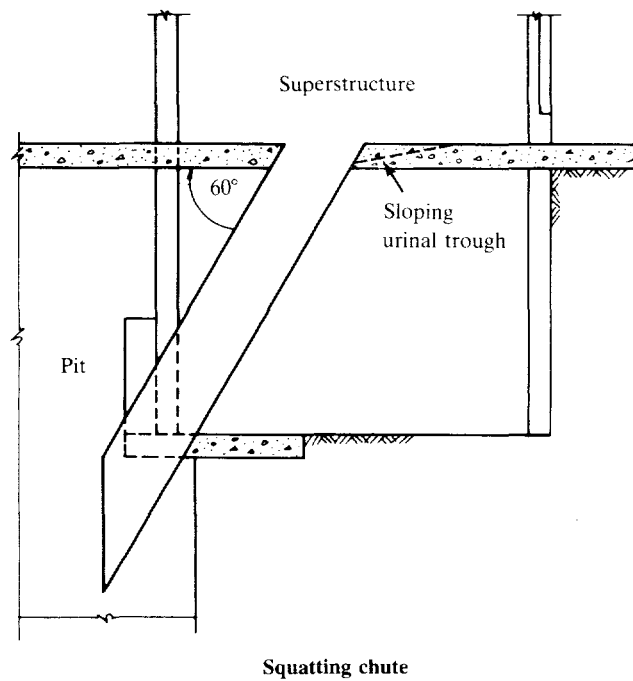
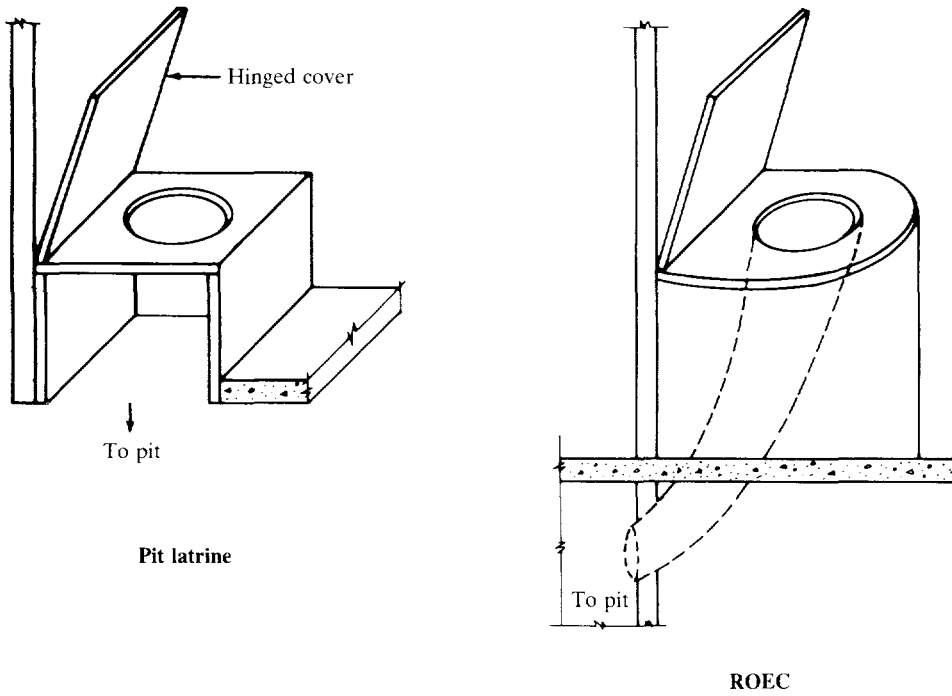

Note: The pedestal hole should be 100 millimeters in diameter for use by children, 200 millimeters for adults. Unsupported fiberglass should not be used in construction.

Figure 9-4. Water-seal Squatting Plate for PF Toilets Located Immediately above the Pit (millimeters)

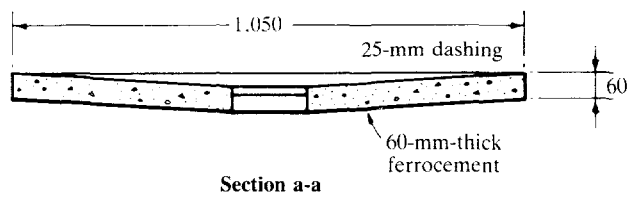
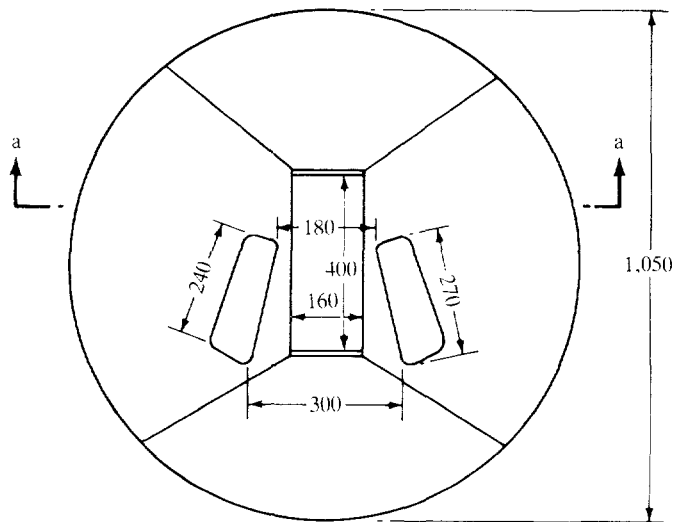
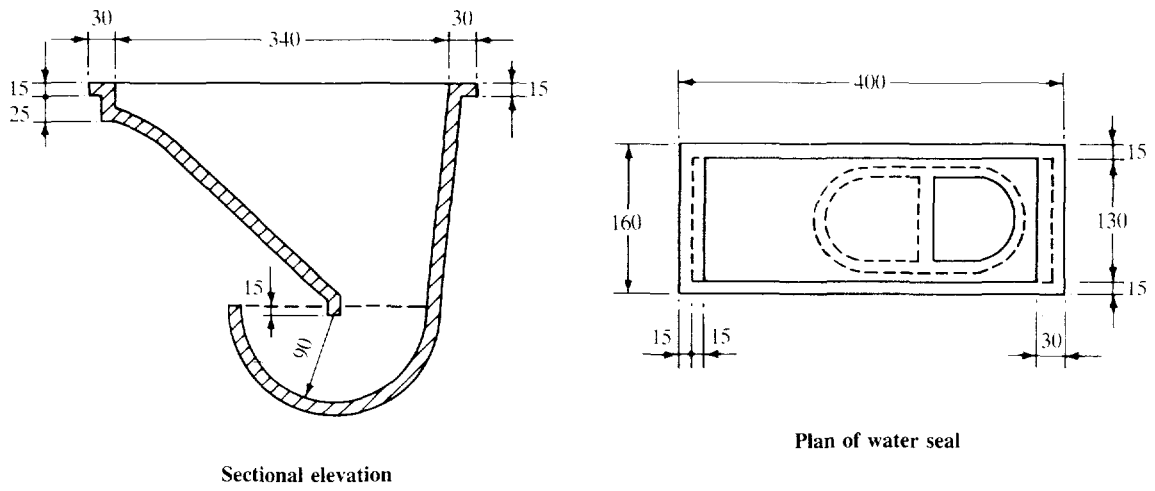

Source: Adapted from Wagner and Lanoix (1958).

Figure 9-5. Galvanized Sheet-metal Water-seal Unit for PF Toilets
 Located Immediately above the Pit
 (millimeters)

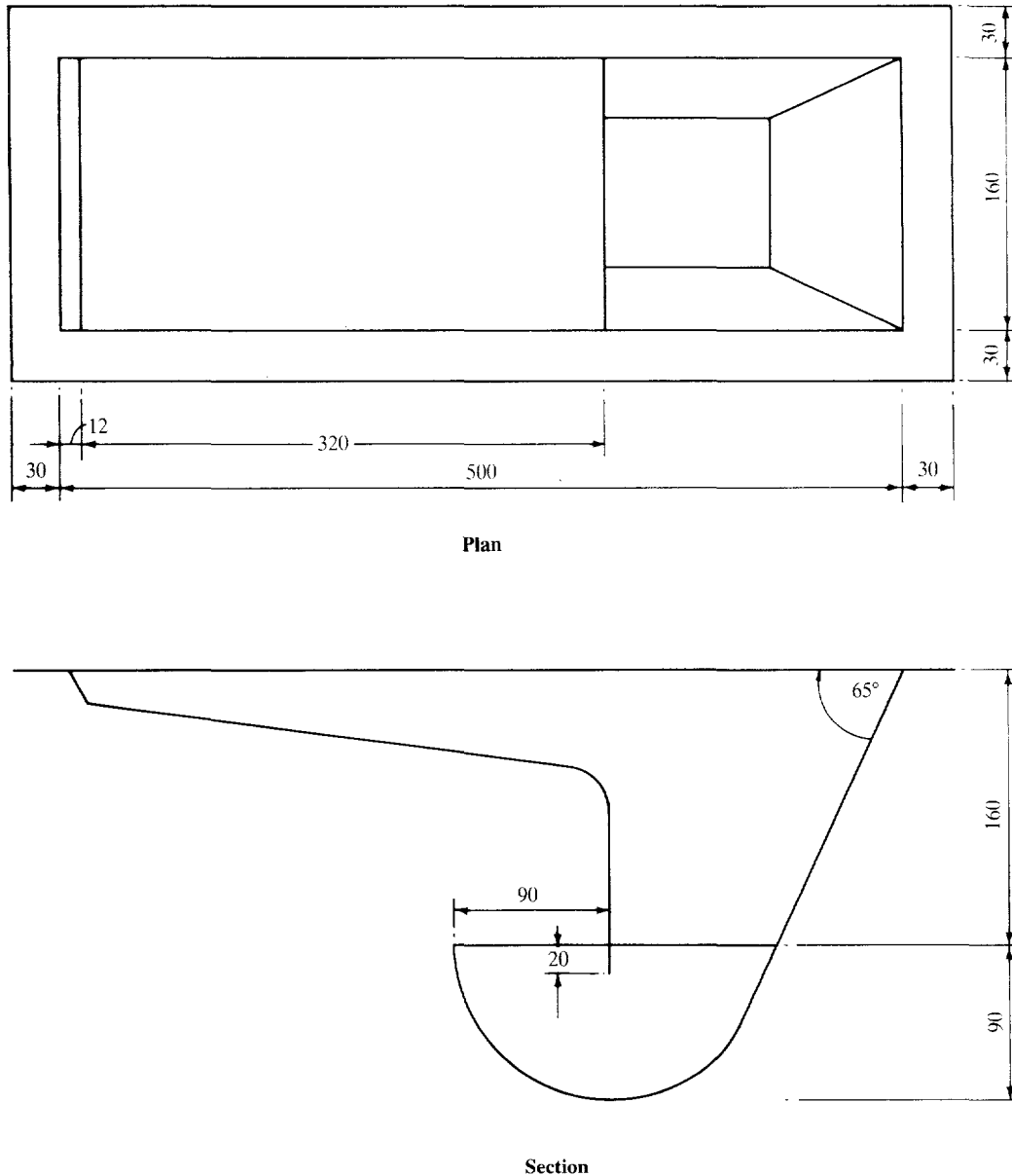

ternal surfaces of ROEC's should be smooth and accessible for cleaning. To encourage proper use by children and to prevent their falling into the pit, a second smaller (150-millimeter diameter) seat should be provided. This may be a separate seat on the seat cover. A cover should always be provided to minimize fly access, but it should have several small holes drilled in it to permit the through draft necessary for odor control in these toilets. Alternative designs are shown in figure 9-3.

Squatting Plates for Composting, PF, and Vault Toilets

Squatting plates for composting toilets are the same as those for VIP latrines, except that, if urine is to be excluded, a suitable urine drainage channel must be provided (see chapter 11, figure 11-1).

In PF and vault toilets, if the squatting plate is

Figure 9-6. *Plastic or Fiberglass Water-seal Toilet*
(millimeters)

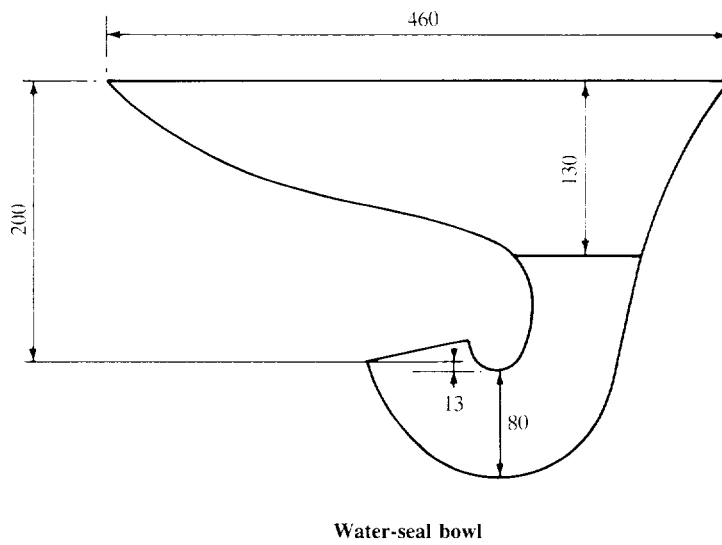
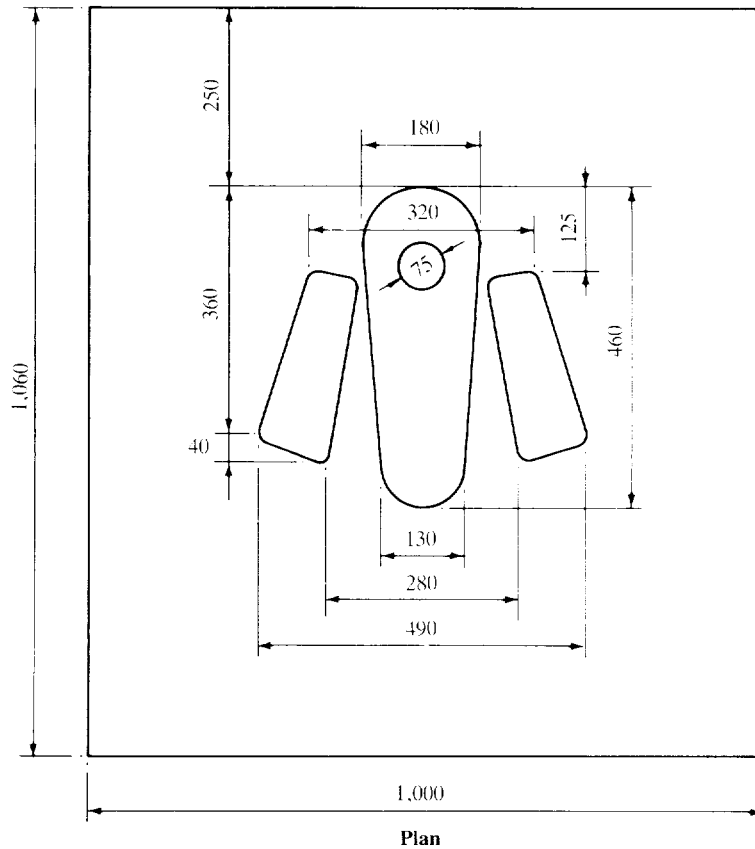

Source: Adapted from Wagner and Lanoix (1958).

Figure 9-7. PF Units for Displaced Pits
(millimeters)

A. Cement mortar or ceramic pan

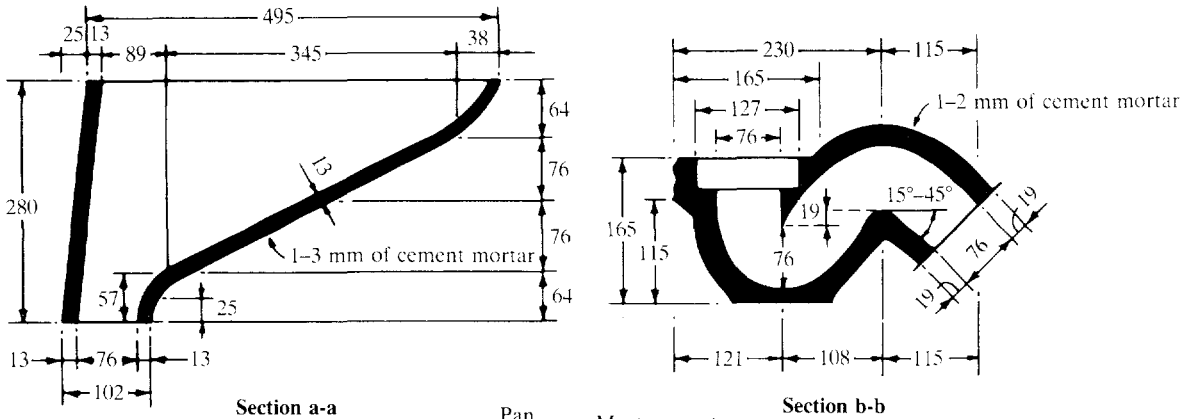
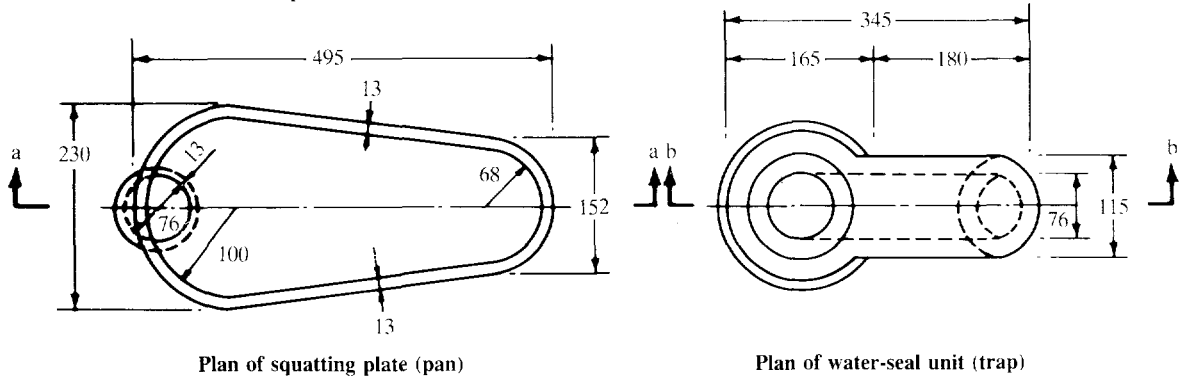

B. Ceramic pedestal

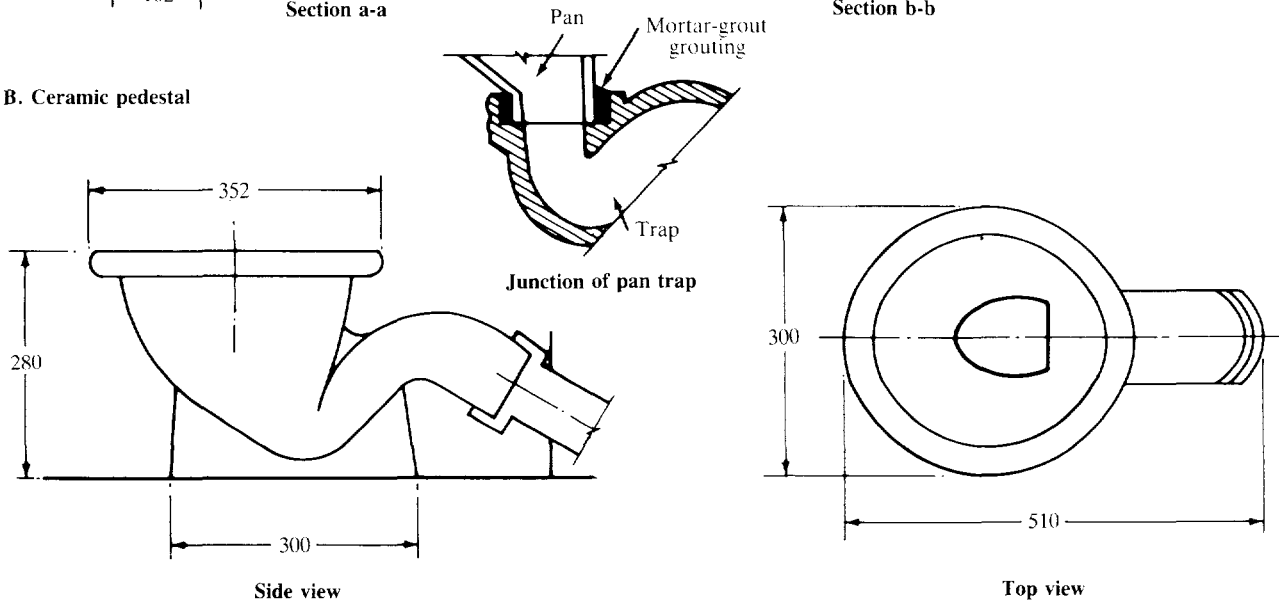

Sources: A adapted from Wagner and Lanoix (1958); B adapted from CIMDER (Center for Multidisciplinary Investigation's in Rural Development), Colombia.

situated immediately over the pit or vault (for further details, see chapters 12 and 18), the design is of the type shown in figure 9-4. This unit is most easily made from ferrocement or reinforced plastic. An alternative sheet metal design, essentially a PF modification of the Tanzanian flap-trap described above, is shown in figure 9-5. It is essential that this unit be properly and completely galvanized before it is cast into the ferrocement slab. Figure 9-6 shows a similar design that can easily be produced in plastic. When used with VIP latrines, all designs of squatting plates discharging to the pit should be placed to flush forward to avoid erosion of the pit wall.

If the squatting plate is connected to a completely displaced pit or vault, the design is of the type shown in figure 9-7.

Pedestal Seats for PF and Vault Toilets

These are essentially the same design as for cistern-flush toilets but with a smaller water seal (generally 15 to 20 millimeters) and a smaller exposed surface area and volume of water (around 75 square centimeters and 2 liters, respectively). A low-cost ceramic design such as that from Colombia (shown in figure 9-7B) cost about \$5 in 1978.

10

VIP Latrines

CONVENTIONAL PIT LATRINES are the most common sanitation facility used in developing countries. In its simplest form, a pit latrine has three components: a pit, a squatting plate (or seat and riser) and foundation, and a superstructure.

A typical arrangement is shown in figure 10-1. The pit is simply a hole in the ground into which excreta fall. When the pit is filled to within 1 meter of the surface, the superstructure and squatting plate are removed and the pit filled up with soil. A new pit is then dug nearby.

The simple unimproved pit latrine has two major disadvantages: it usually is malodorous, and flies or mosquitoes readily breed in it, particularly when it is filled to within 1 meter of the surface. These undesirable attributes have led to the rejection of the pit latrine in favor of other, far more expensive forms of sanitation, but these problems are almost completely absent in VIP latrines, VIDP latrines, and ROEC's. It is therefore recommended that unimproved pit latrines of the type shown in figure 10-1 no longer be built, and that those that do exist should be converted.

Recent work has provided designs for pit latrines that are odorless and have minimal fly and mosquito nuisance. VIP latrines (figure 10-2) are a hygienic, low-cost, and more acceptable form of sanitation that has only minimal requirements for user care and municipal involvement. The pit is slightly offset to make room for an external vent pipe. The vent pipe should be at least 75 millimeters in diameter (ranging up to 200 millimeters); it may be painted black and located on the sunny side of the latrine superstructure to heat the vent pipe more than the rest of the structure and thus augment the updraft. The air inside the vent pipe will be aspirated and create an updraft and a corresponding downdraft through the squatting plate. Any odors emanating from the pit contents are expelled via the vent pipe, leaving the

superstructure odor free. The pit may be provided with removable cover sections to allow desludging.

Recent work has indicated that pit ventilation may also have an important role in reducing fly and mosquito breeding. The draft discourages adult flies and mosquitoes from entering and laying eggs. Nevertheless, some eggs will be laid and eventually adults will emerge. If the vent pipe is large enough to let light into the pit, and if the superstructure is sufficiently dark, the adults will try to escape up the vent pipe. The vent pipe, however, is covered by a gauze screen so that the flies are prevented from escaping, and they eventually fall back to die in the pit.

Both the vent pipe and the gauze screen must be made from corrosion-resistant materials (for example, asbestos cement, fiberglass, PVC). Little detailed work has been done on the design of the vent pipe. At present it is recommended that the pipe diameter should be 75 to 200 millimeters and that it should extend 300 to 600 millimeters above the roof. Local wind patterns and the diurnal variation in ambient temperatures affect ventilation efficiency: theoretical and field work on these aspects is continuing.

VIDP Latrines

To eliminate the need to construct very deep pits, to preclude the necessity of constructing another latrine once the pit is full, and to facilitate the emptying of the pit where space for a replacement latrine does not exist, a double-pit latrine should be used. A VIDP latrine differs in design from the VIP latrine only in its having two pits (see figure 10-3). Two pits can be provided by constructing a separation wall in the VIP pit or by constructing two separate pits. Each of the two pits should be designed to have an operating life of at least one year before it is necessary to seal the pit and switch to the second pit. The VIDP super-

Figure 10-1. *Conventional Unimproved Pit Latrine*
(millimeters)

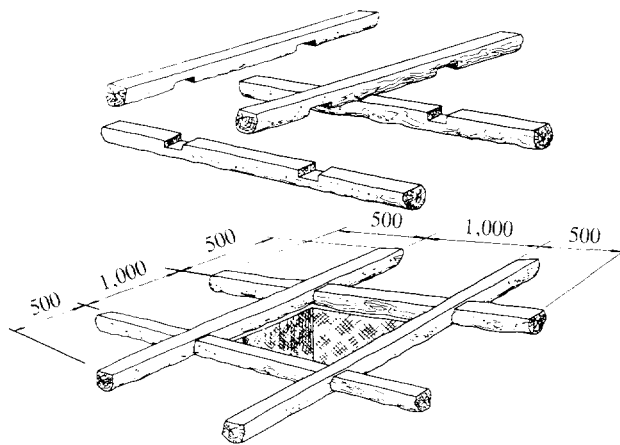
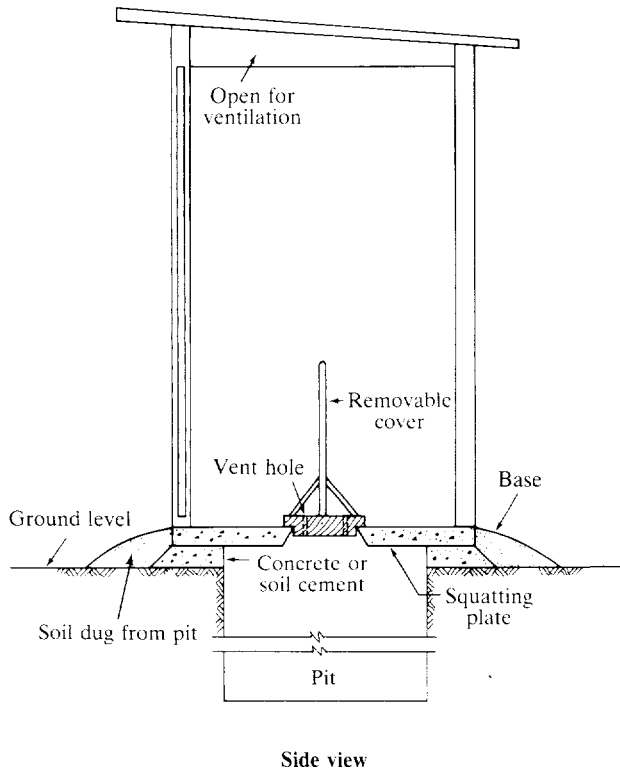

Alternative base using hewn logs

Note: In termite-infested areas, use treated wood or termite barrier.

Source: Adapted from Wagner and Lanoix (1958).

structure and squatting plate arrangements would be similar to that of the DVC toilet (see chapter 11). Regular VIP squatting plates would be used, however, where urine separation is not required.

Operation and maintenance of the VIDP is the same for pit emptying as that for the VIP. With two pits available, one pit would be used until full and then sealed while the second pit is in use. When the latter is almost full, the first pit would be emptied and put back into use once more. By alternating, the two pits can be used indefinitely. Because of the long residence time (a minimum of one year) of the decomposing excreta in the pit not in use at the time, pathogenic organisms will have been destroyed by the time the pit needs to be emptied. The excavated humus-like material can be used as a soil conditioner or disposed of without fear of contamination.

In permeable soil the liquid fraction of the excreta, together with the water used for latrine and personal cleansing, percolates into the soil and so reduces the volume of excreta in the pit. The solid fraction of the excreta is slowly decomposed by anaerobic digestion, and this also reduces the volume of excreta remaining in the pit. Thus, the long-term accumulation of solids in the pit is very much less than the total quantity of excreta added. For purposes of design, the required capacity of a dry pit should be taken as 0.06 cubic meter per person yearly. In areas where anal cleansing materials that are not readily decomposed (such as maize cobs, mud balls, cement bags) are used, this figure should be increased by 50 percent.

VIP latrines, VIDP latrines, and ROEC's are designed for use without water; that is, there is no need to "flush" excreta into the pit. Where flushing is desired, a PF latrine should be used (see chapter 12) because it is a superior latrine for applications where water is available and the user is accustomed to the use of water for flushing, anal cleansing, or both.

Pits should be constructed so as not to extend below the water table; the pit thus remains dry, and groundwater contamination is minimized. In areas where the water table is within 1 meter of the ground surface, or where excavation is extremely difficult (for example, in rocky ground), a built-up pit can be used (see figure 10-5). The raised plinth need not be more than 1 meter above ground level, and the watertight lining should extend at least 0.5 meter, and preferably 1 meter, below ground level. With a movable superstructure, a long, shallow, multiple-chamber pit can be constructed and desludged periodically.

Desludging of pits may be necessary where space is limited; it can be done manually or mechanically.

Figure 10-2. *VIP Latrine*
(millimeters)

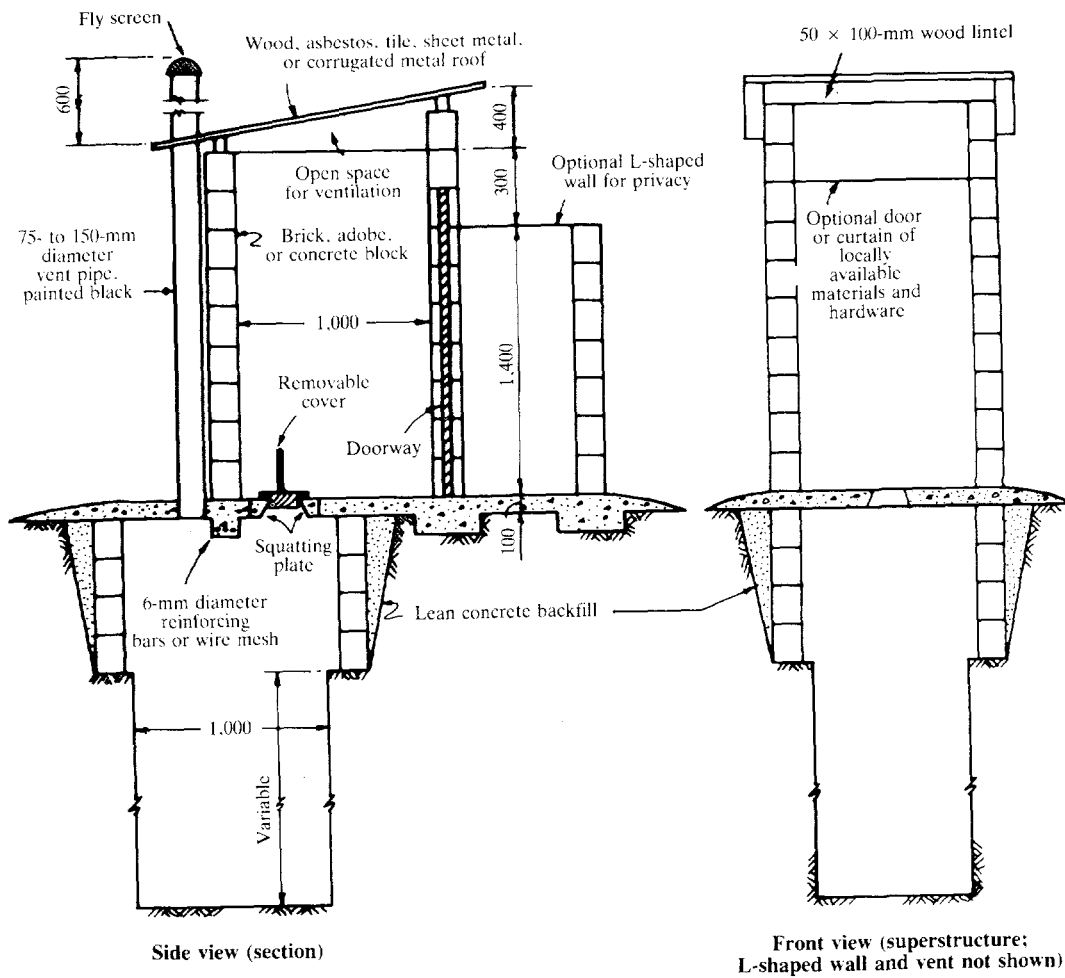

Note: In the side view, a pedestal seat or bench may be substituted for the squatting plate. An opening for desludging may be provided next to the vent. Dimensions of the bricks or concrete blocks may vary according to local practice. Wooden beams, flooring, and siding may be substituted for concrete block walls and substructure.

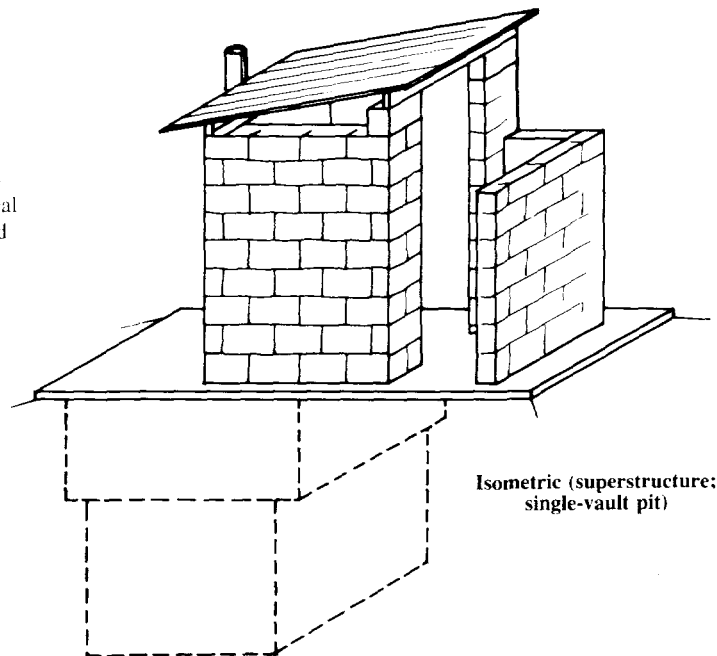
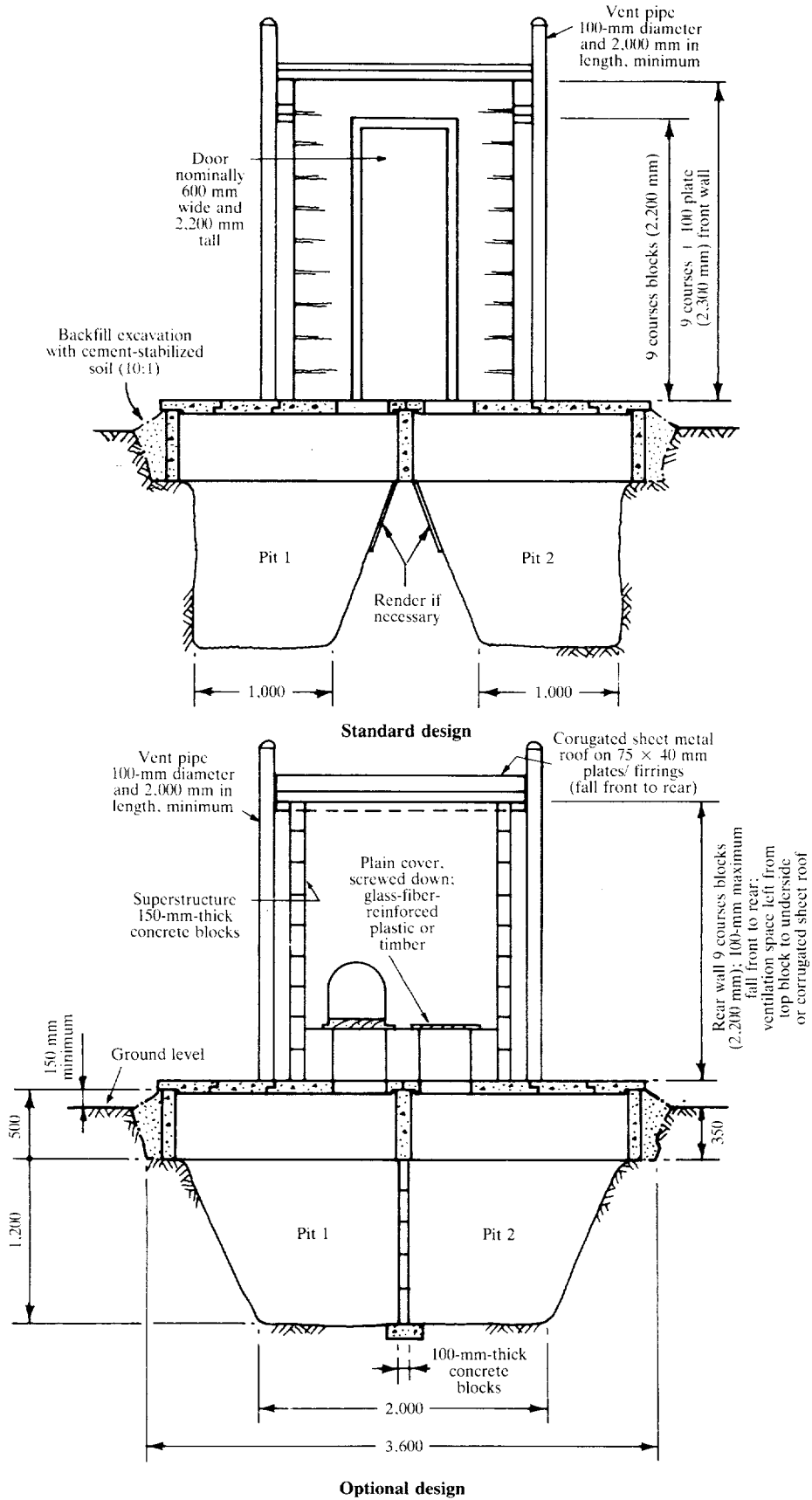

Figure 10-3. VIPD Latrine



Source: Adapted from a drawing by R. Carroll.

provided adequate precautions are taken to prevent the spread of pathogens. Care must be taken that the emptying methods adopted do not lead to collapse of unlined pit walls (as may happen when high-pressure hydraulic flushing is employed).

ROEC'S

An alternative design for a VIP latrine is the ROEC, shown in figure 10-4. In this latrine the pit is completely offset, and excreta are introduced into the pit via a chute. A vent pipe is provided, as in the VIP latrine, to control fly and odor nuisance. A disadvantage of the ROEC, however, is that the chute is easily fouled with excreta and thus may provide a site for fly breeding. Although some researchers have reported that slime growth prevents fouling, the chute generally has to be cleaned regularly with a long-handled brush. In spite of this small disadvantage, ROEC's are sometimes preferred to VIP latrines for the following reasons:

- The pit is larger and thus has a longer life than other shallow pits.
- Since the pit is completely displaced, the users (particularly children) have no fear of falling into it.
- It is not possible to see the excreta in the pit.
- The pit can be easily emptied, so that the superstructure can be a permanent facility.

ROEC's have proved extremely satisfactory in southern Africa, where some units have been in continuous use for over twenty years. Recent experiments in Tanzania have also demonstrated their technical and social acceptability.

Pit Design

The volume (V) of pits less than 4 meters deep may be calculated from the equation:

$$V = 1.33 CPN,$$

where C = pit design capacity, cubic meters per person per year

P = number of people using the latrine

N = number of years the pit is to be used before emptying.

The capacity of a dry pit should be 0.6 cubic meter per person per year. Where anal cleansing materials that are not readily decomposed (such as maize cobs, mud balls, cement bags, and so forth) are used, this figure should be increased by 50 percent. For wet

pits, the capacity should be 0.04 cubic meter per person per year.

The factor 1.33 is introduced as the pit is filled in with earth or emptied when it is three-quarters full. For the unusual case of pits deeper than 4 meters, $V = CPN + 1$ to allow for filling the upper 1 meter with earth. Where soil conditions permit, large diameter or cross-section pits may be constructed, although special care must be given to supporting the latrine base and superstructure. Some traditional pit designs are shown in figure 10-5.

VIP and VIDP latrines

In the case of VIP latrines the pit is approximately 1 square meter in cross-section, and its depth is then readily calculated from the required volume. Depths are usually in the range of 3 to 8 meters, although pit depths of 12 meters or more are found where soils are particularly suitable. With VIP latrines, it may be advantageous to use enlarged pits if the ground conditions are suitable.

The upper part of the pit should be lined so that it can properly support the squatting plate and superstructure. If this is not done, the pit may collapse. In unstable soil conditions it may be necessary to extend this lining down to the bottom of the pit (figure 10-5), but care must be taken to ensure that the lining does not prevent percolation.

A VIDP latrine differs from a VIP only in that it has two alternating pits. When one is full, the pit should rest at least one year before it is emptied to ensure pathogen destruction; pit depths can be varied to reflect soil condition (suitability) and desired emptying frequency. To facilitate emptying and prevent collapse of the partition wall, however, the pit should not be as deep as that of a VIP.

All pits should be constructed to prevent surface water from entering. This requires grading of the surface to ensure diversion of surface drainage. In cases where it is partially offset from the superstructure, the pit should normally be constructed on the downhill side.

ROEC's

These latrines normally have the advantage over VIP latrines that the pit, being completely offset, can be larger and thus lasts longer. The design lifetime should be fifteen to twenty years. The width of the pit is generally about 1 meter and, for easy desludging, its depth should not exceed 3 meters; its length can thus be readily calculated from the equation given above (see figure 10-4).

Figure 10-4. ROEC
(millimeters)

A. Plan

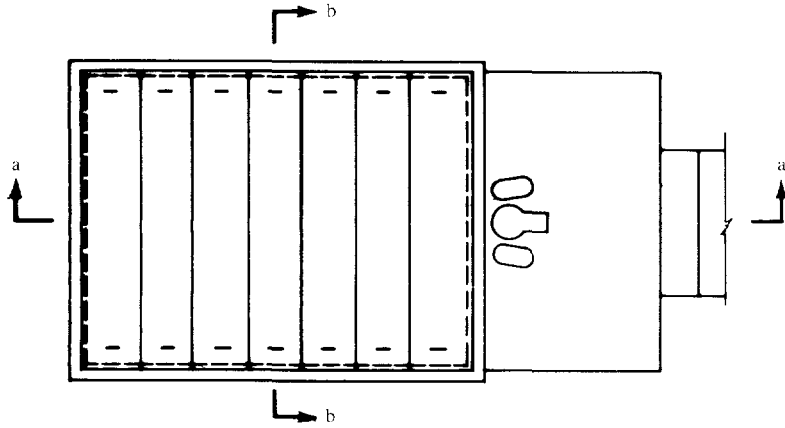

Plan (with latrine superstructure removed)

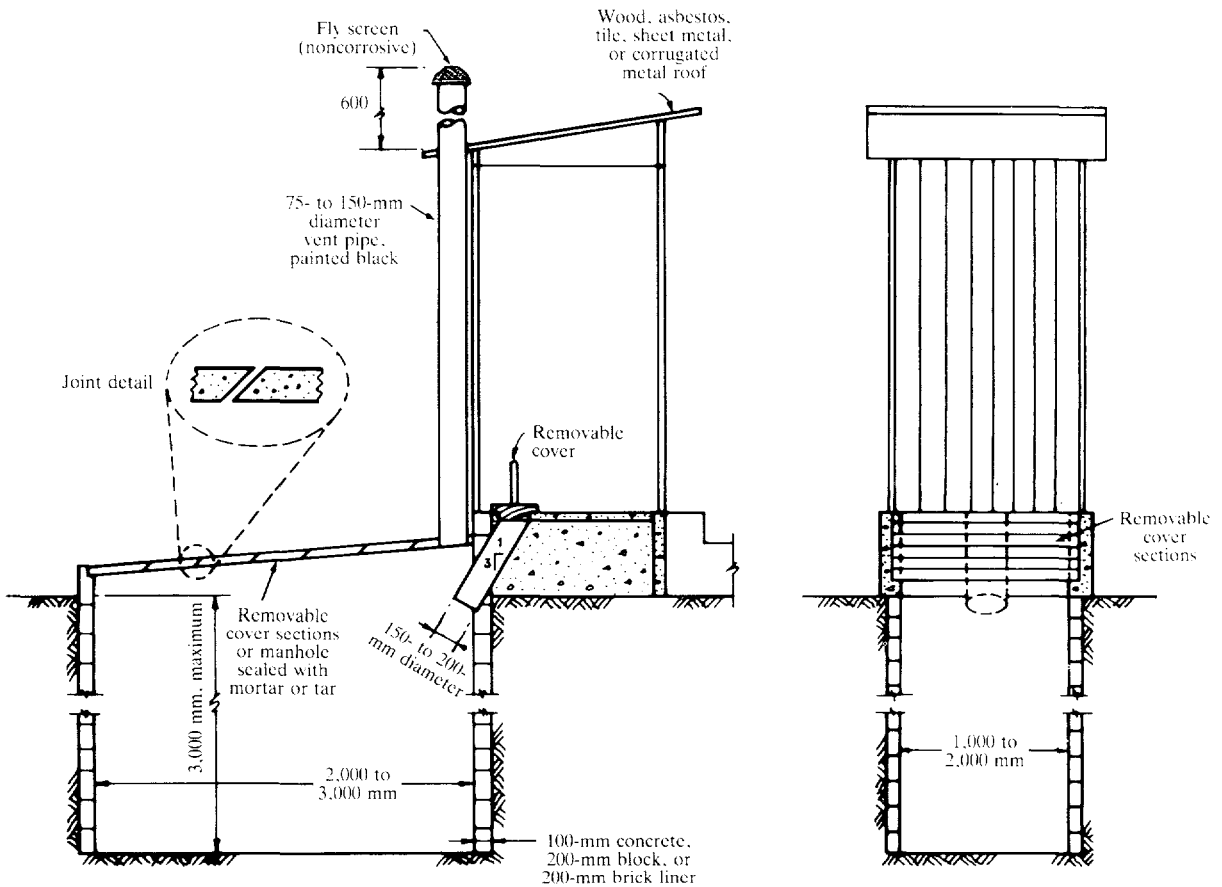

Section a-a

Section b-b
(vent not shown)

B. Structural details

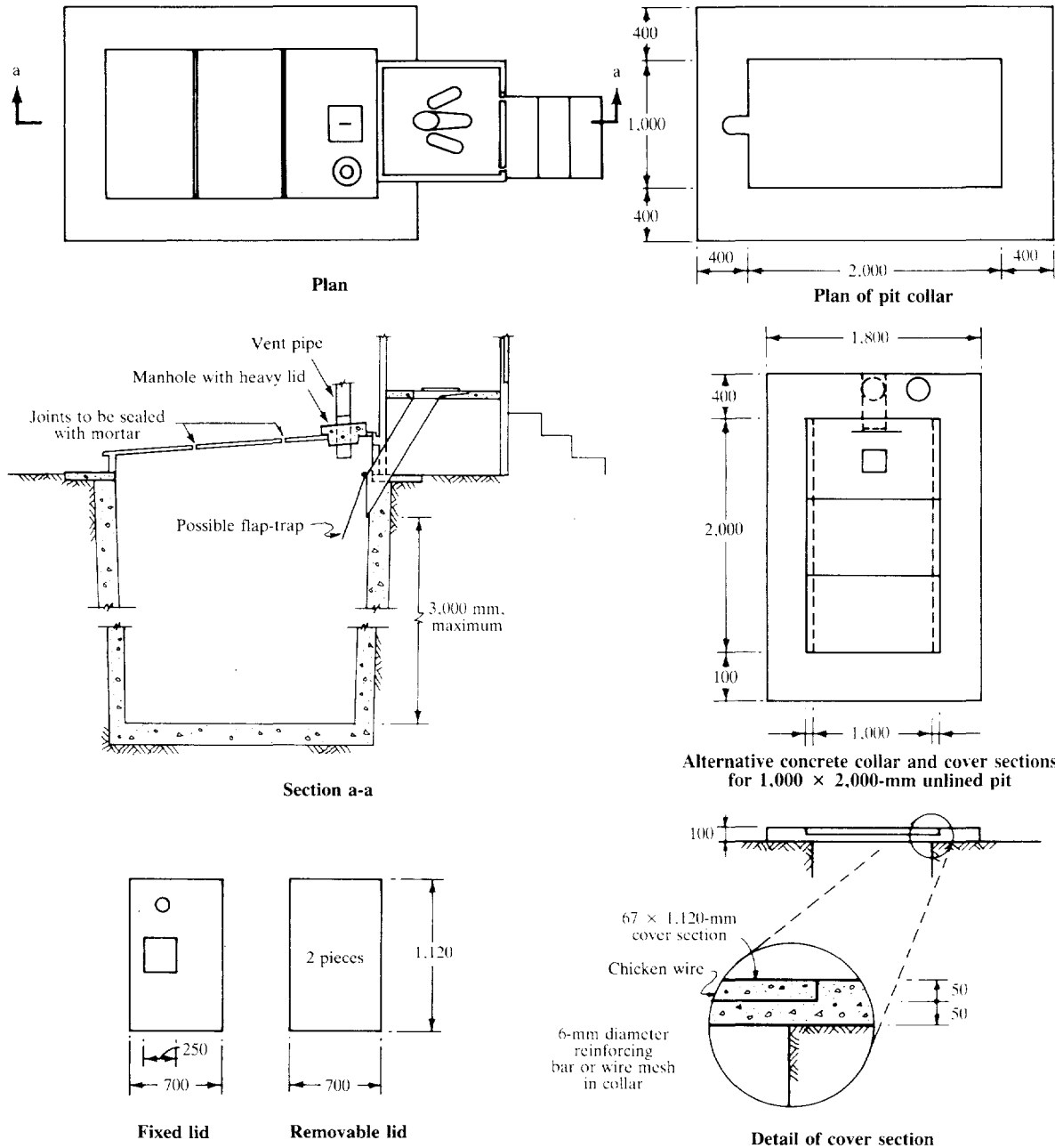

Note: Pedestal seat with curved chute may be substituted for squatting plate. Construction materials and dimensions for the superstructure may vary according to local practice. The vent should be placed for maximum exposure to sunlight.

Source: Adapted from a drawing by U. Winblad.

Figure 10-5. *Alternative Pit Designs*
(millimeters)

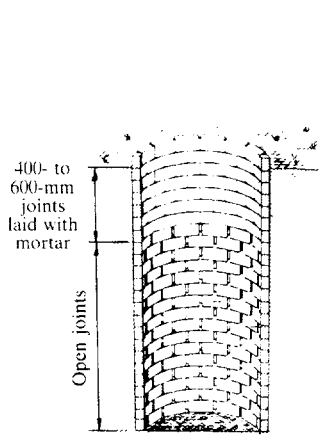

Circular pit with brick lining

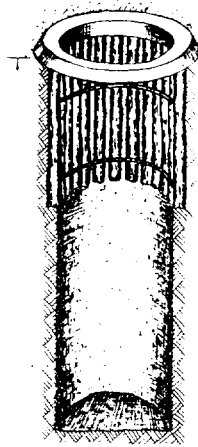

Round pit with partial lining of tree limbs

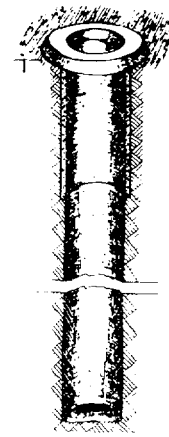

Bored pit with concrete lining

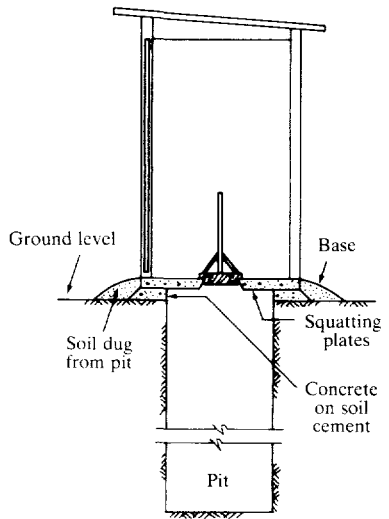

Unlined pit

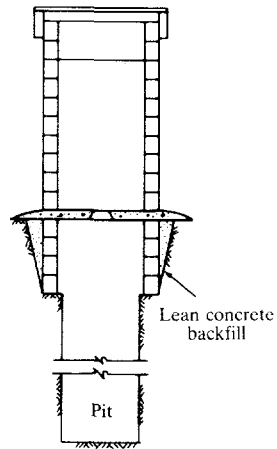

Square pit with partial concrete-block lining

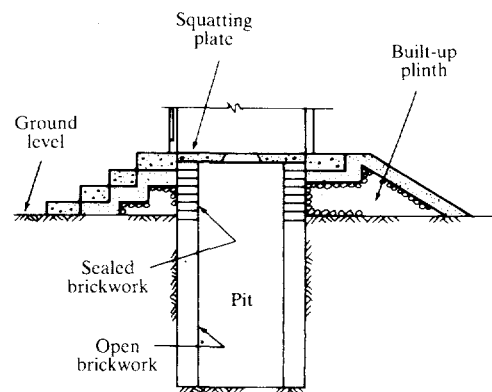

Raised pit latrine for use in areas of high groundwater table

Sources: Top row, adapted from Wagner and Lanoix (1958); bottom row, World Bank.

Bore-hole latrines

This type of pit latrine is not recommended as a household sanitation facility since it is too small (usually only 400 millimeters in diameter and up to 4 meters deep for hand augers) and cannot be ventilated. Bore-hole latrines thus have a short lifetime (one to two years) and generally unacceptable levels of fly and odor nuisance. Where mechanical augers are available, greater depths and lifetimes can be provided, but ventilation is still a problem (see figure 10-5).

Material and labor requirements

Unskilled labor is required for excavation of the pit, and semiskilled labor is required for lining the pit, casting the squatting plate, and building the superstructure. Usually the unskilled labor can be provided by the householder, with municipal guidance and inspection.

Material requirements are for the pit lining, the squatting plate, and the superstructure. Although a variety of materials can be used, most commonly brick or concrete blocks are chosen for the lining and superstructure, with corrugated galvanized iron or asbestos-cement sheets and wooden beams for the roof. Other lining materials include closely spaced timber poles, used tires, and fiber mats. The squatting plate is usually made of concrete. All required materials should be locally available. The support for the squatting plate (or pedestal) and superstructure may be provided by lumber beams extending well beyond the pits, by a reinforced concrete slab resting on a suitable pit lining, or by a reinforced concrete collar extending, for example, 40 centimeters beyond the wall of an unlined pit.

Complementary investments and water requirements

Sullage disposal facilities are required. The precise type of facility depends on the quantity of sullage generated by the household (see chapters 15 and 20).

Only minimal volumes of water are required to clean the squatting slab and, if use of water is customary, for anal cleansing (though in this case a PF unit would be more appropriate).

Maintenance requirements

Pit latrines require good maintenance. This maintenance, however, is of a very simple kind and con-

sists principally of keeping the squatting plate and superstructure clean. To prevent mosquito breeding in wet pits, a cupful of a suitable inhibitor (such as wood ash, lye, used lubricating oil, or kerosene) should be added to the pit each week.

In many parts of the world, pit latrines have become grossly fouled and often constitute a greater health hazard than promiscuous defecation in the garden or alleys. This is not because pit latrines have any inherent tendency to become fouled, but because they have often been introduced without sufficient user participation or education into communities that had never previously had any sanitation facilities whatsoever. In such communities, other types of latrines would doubtless become equally fouled.

Since the construction of pit latrines is very simple, it may be largely left to the householders. Municipal responsibilities can thus be restricted to enforcing and assisting in the achievement of building standards and to providing the householders with whatever type of credit or other financial assistance is appropriate. It may be necessary for the municipality to establish facilities for the mass production of squatting plates; this may be done either by municipal employees or in the private sector. The municipal authority should also be responsible for ensuring that the latrines are properly used and maintained. It may be necessary to assist householders with re-digging or emptying their latrines when full, and detailed arrangements for these services should be worked out at the planning stage.

Factors Affecting Suitability

VIP and VIDP latrines and ROEC's are suitable in low- and medium-density areas (up to approximately 300 persons per hectare). In such areas houses are normally single storied, and there is sufficient space on each plot for at least two pit sites (one in use and the other in reserve). The latrines can be used at much higher densities (500 to 600 persons per hectare), however, if the pit volume is increased or if pits and vaults are easily accessible for emptying and if sullage water disposal is properly managed. The VIDP is particularly useful at high population densities. All three types of latrine are easy to construct (except in sandy or rocky ground, or when the water table is high), and usually much, if not all, of the construction can be done by the users. The construction materials are standard, and none generally has to be specially imported.

Health aspects

Provided that the squatting plate is kept clean, a VIP latrine or ROEC poses virtually no greater health risk to the user than does a flush toilet. The only slightly increased risk is that of fly and mosquito breeding. This is unlikely to be a serious nuisance, however, if the latrine is kept dry and clean, fly-breeding inhibitors are used, the ventilation system is properly designed, and the users keep the slab hole covered.

The pit contents can be safely dug out after they have been sealed in the ground at least twelve months. At most, there will be only a few viable *Ascaris* ova remaining after this time. If, as was recommended earlier, the pit has a minimum life of five years, its contents will not be dug out before at least another five years have elapsed (since a second pit will have been in use for that period), and after this time the pit contents will not contain any viable excreted pathogens whatsoever.

Costs

The cost of a VIP or VIDP latrine includes costs of the labor required for pit excavation and lining and of the purchase and fabrication of the squatting slab, the vent pipe, and the superstructure. For a ROEC the cost of the chute must be added. In most cases the superstructure cost will be the largest component, amounting to about half of the total. Thus, any reduction in superstructure cost through the use of inexpensive local materials or self-help labor will significantly reduce total costs. Similarly, an overdesigned superstructure can increase the cost of a VIP or VIDP latrine or ROEC to the point where it loses its economic advantage over other systems.

The total construction cost of a VIP or VIDP latrine ranges from \$50 to \$150; the lower figure assumes that household labor is used for excavation and building the superstructure. If the ground is rocky or if

no inexpensive superstructure materials are available, the cost may be higher than \$150. With a larger pit than that of the VIP latrine and the addition of a chute, a ROEC will cost about \$75 to \$200 to construct. The operating and maintenance requirements of VIP or VIDP latrines and ROEC's are those of cleaning the user area and periodic emptying.

Potential for upgrading and resource recovery

VIP latrines, VIDP latrines, and ROEC's can be easily upgraded to PF toilets. The necessary design modifications are discussed in chapters 6 and 7.

VIDP latrines permit waste reuse; when dug out, the well-aged pit contents may be safely used as humus on gardens. The contents of VIP and ROEC pits will, however, contain some fresh excreta and will require treatment (such as composting) before they can be safely used.

Advantages and disadvantages

The main advantages of well-maintained VIP latrines, VIDP latrines, and ROEC's are:

- Lowest annual costs
- Ease of construction and maintenance
- All types of anal cleansing materials may be used
- Absence of odor nuisance and minimal fly and mosquito nuisance
- Minimal water requirements
- Low level of municipal involvement
- Minimal risks to health
- Good potential for upgrading.

Their main disadvantages are that they are unsuitable for high-density urban areas, they may pollute the groundwater, and, except for VIDP's, they must be emptied or replaced when full. They can be upgraded to PF toilets with a water seal. They also require that separate arrangements be made for sullage disposal.

11

Composting Toilets

HOUSEHOLD SYSTEMS for composting night soil and other organic materials are used under a variety of conditions. They are successful in both developing and industrial countries when they receive a high degree of user care and attention. This is most likely to occur when there is an urgent need for fertilizer or when there is a high degree of environmental concern. There are two kinds of systems, continuous and batch.

Continuous Composting Toilets

Continuous composting toilets are developments of a Swedish design known as a "multrum" (see figure 11-1). The composting chamber, which is situated immediately below the squatting plate, has a sloping floor above which are suspended inverted U- or V-shaped channels. Grass, straw, ash, sawdust, and easily biodegradable household refuse as well as excreta are added to the composting chamber. In some designs, air from the outside enters by means of suspended channels said to promote aerobic conditions in the composting chamber. The composting material slowly moves down the chamber and into a humus vault, from which it must be regularly removed. The moisture content of the composting material and the humus should be 40 to 60 percent, and the added organic matter acts both to absorb urine and the water used for latrine and anal cleansing and to achieve a carbon-nitrogen ratio in the range of about 20:1 to 30:1. The bulky nature of grass and straw also helps to promote aerobic conditions.

If the temperature in the composting chamber could be raised by bacterial activity to above 50°C, the survival of excreted pathogens would be zero, with even *Ascaris* ova being totally eliminated (see chapter 15). Recent field trials of continuous composting toilets in Tanzania and Botswana, however, have shown that the rise in temperature is only a few

degrees above ambient, indicating that in practice the composting process is not aerobic. In these trials continuous composters were found to be extremely sensitive to the degree of user care: the humus has to be removed at the correct rate, and organic matter has to be added in the correct quantities. The best results have been obtained from scheduled additions of maize husks with dry soil from yard sweepings. Only a minimum of liquid can be added. Even with the required sophisticated level of user care, short circuiting may still occur within the system, and viable excreted pathogens can be washed down into the humus chamber. The results of these field trials indicate that continuous composting toilets are presently not recommended for use in developing countries.

Batch Composting Toilets

Double vault composting (DVC) toilets are the most common type of batch composting toilet. Designs are shown in figures 11-2 and 11-3. The design details, such as fixed or movable superstructures, vary, but all DVC toilets have certain design principles and operational requirements in common. There are two adjacent vaults, one of which is used until it is about three-quarters full, when it is filled with earth and sealed, and the other vault is then used. Ash and biodegradable organic matter are added to the vault to absorb odors and moisture. If ash or organic matter is not added, the toilet acts either as a VIP latrine, if it is unsealed, or as a vault toilet, if it is sealed. When the second vault is filled and sealed, the contents of the first vault are removed and it is put into service again. The composting process takes place anaerobically and requires approximately one year to make the compost microbiologically safe for use as a soil fertilizer.

To produce good composted humus, the optimal moisture content in the vault should be between 40

Figure 11-1. "Multrum" Continuous-composting Toilet
(millimeters)

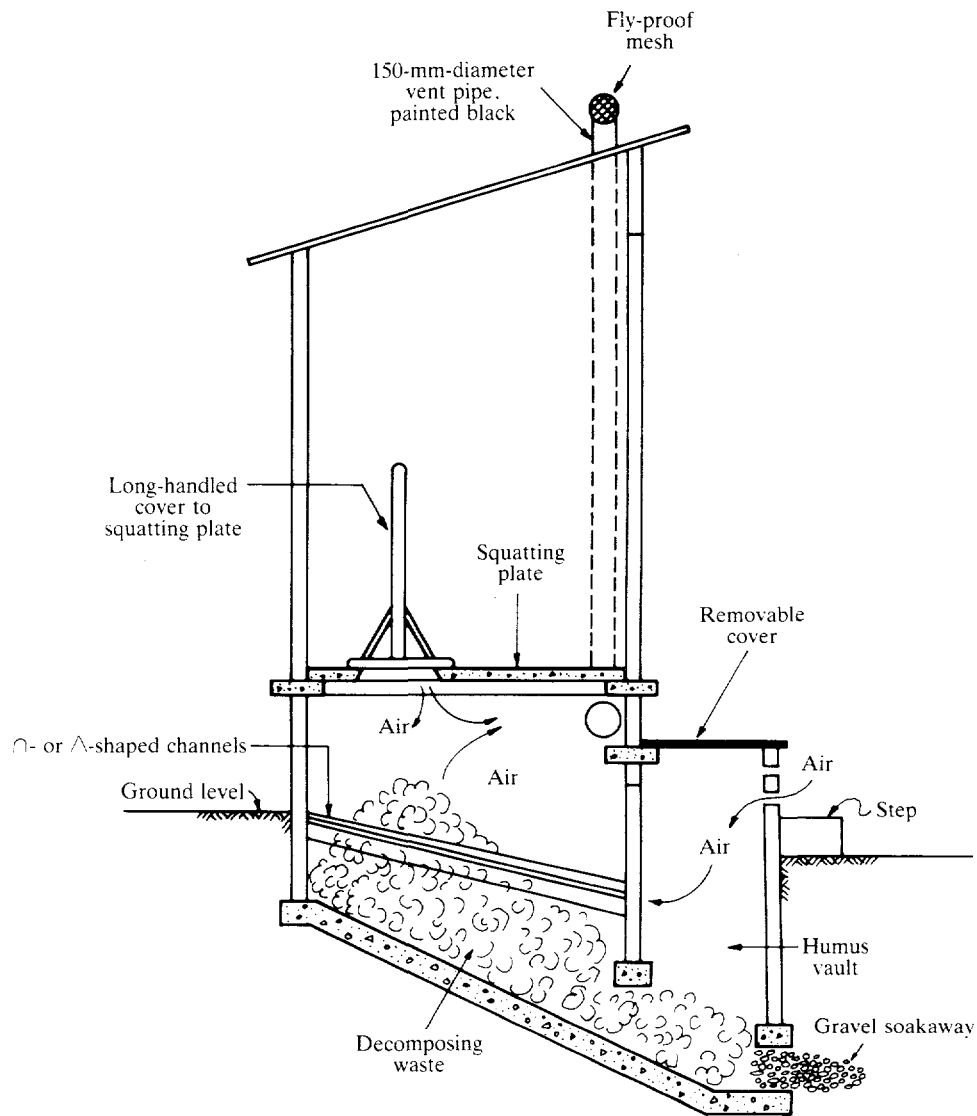

Source: Adapted from a drawing by U. Winblad.

Note: This figure has been included because of widespread interest on the part of many development agencies and officials. Recent intensive efforts by Winblad (personal communication 1981) to ensure adequate user operation and maintenance were unsuccessful. The "multrum" is not recommended for use in developing countries.

and 60 percent. This can be achieved in several ways. In the Vietnamese DVC toilet (figure 11-2), urine is excluded from the vault and either drained to a small gravel soakaway or collected for use as a nitrogenous liquid fertilizer. Direct use is not acceptable in areas where the prevalence of urinary schistosomiasis is high. In the Botswanan and Tanzanian DVC toilets (see figure 11-3), the base of the vault is permeable, permitting infiltration and percolation of urine and

water; this approach is not applicable in areas where there is a high groundwater table. In this situation the vault must be completely sealed, and moisture control depends on the correct addition of absorbent materials such as dried grass, sawdust, and ashes. The addition of ashes also helps to make the excreta alkaline and so aids the composting process. The moisture problem is exacerbated in areas where water is used for anal cleansing.

Figure 11-2. *DVC Toilet Used in Vietnam*
(millimeters)

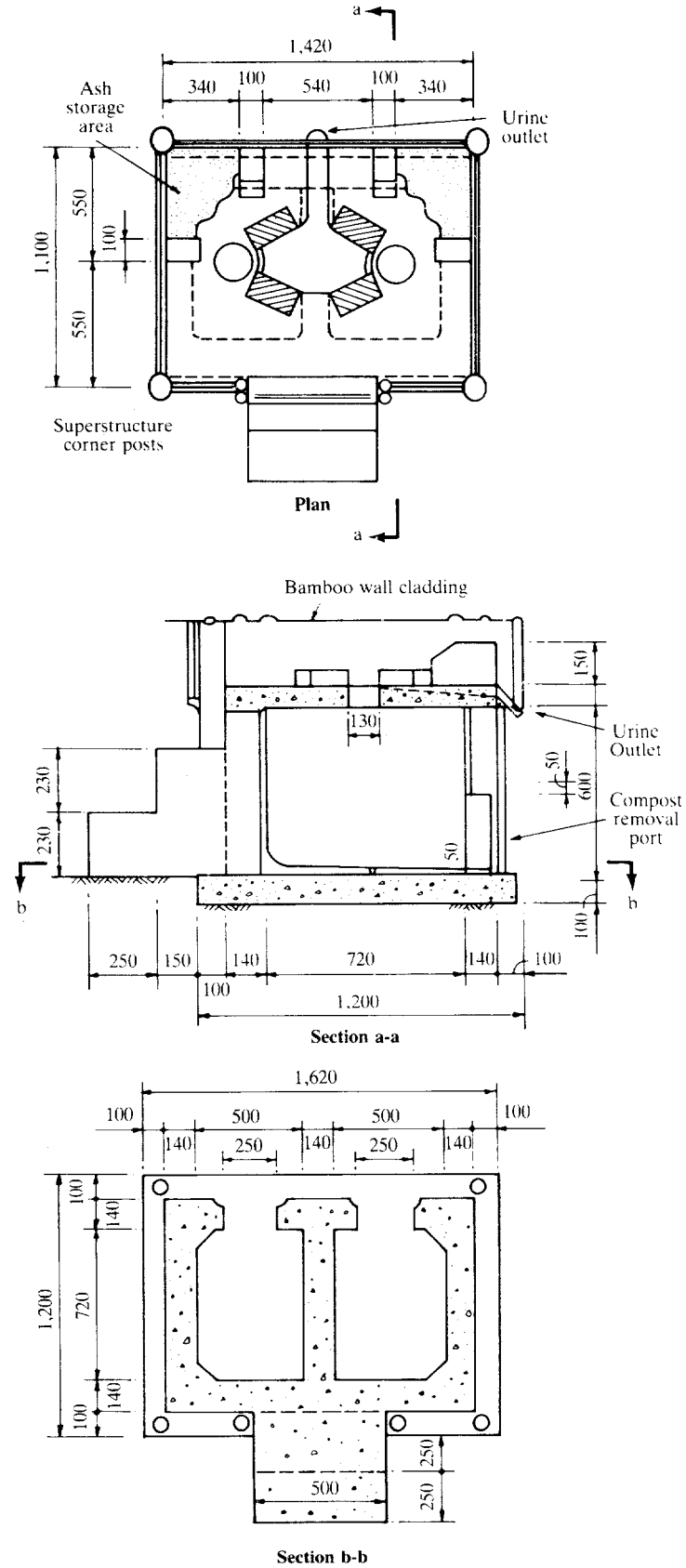
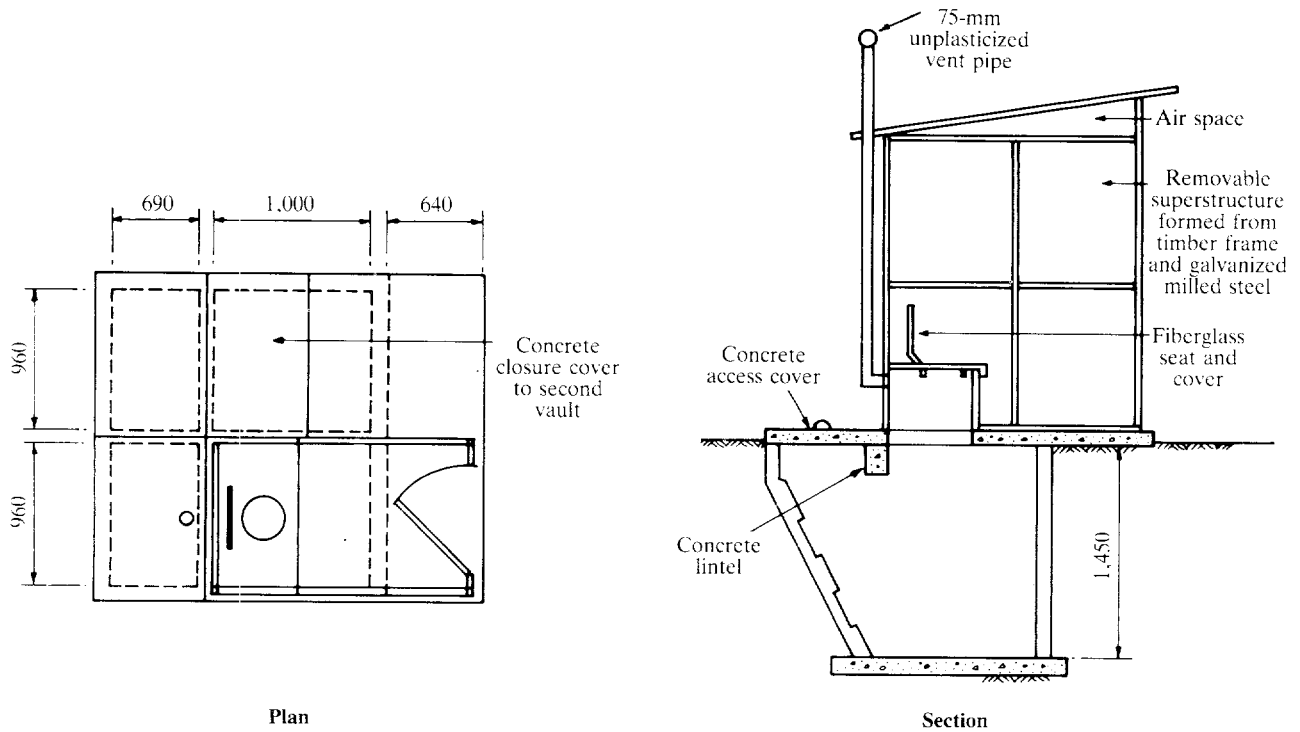
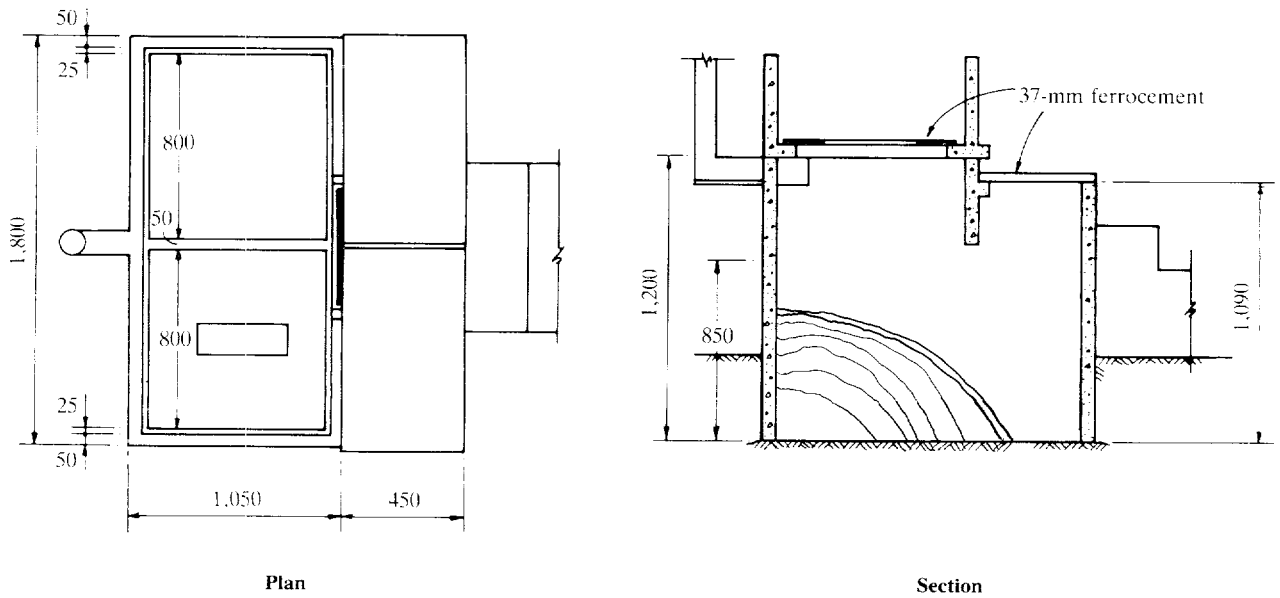

Figure 11-3. DVC Toilets
(millimeters)



Model used in Botswana



Model used in Tanzania

Source: Adapted from a drawing by R. A. Boydell.

It is important to ensure that only one vault is used at a time. In the case of the Vietnamese DVC toilet, which is provided with two squatting plates, this has presumably been achieved by a vigorous user education program. In parts of the world where there are cultural preferences or obligations for one or more members of a household to use a separate toilet, however, several squatting plate locations are indicated. In the Tanzanian DVC toilet, one squatting plate and a continuous slab are provided within a single superstructure, their positions being interchanged as necessary. In the Botswanan design, both the squatting plate and the superstructure are moved into position over the vault in use, while the other is covered by a concrete slab.

Vault Design

Suitable superstructure and squatting plate designs are given in chapters 8 and 9. DVC toilets should be ventilated in the same way as VIP latrines (chapter 10). The correct sizing of the vaults is more difficult, since there is little information available. In Vietnam, the volume of each vault is approximately 0.3 cubic meter; it is used by a family of five to ten for two months. This is equivalent to a minimum design capacity of 0.18 cubic meter per person a year. In Tanzania, the volume of each vault of experimental DVC toilets was 0.6 cubic meter, which served a family of four to six for six months, equivalent to a minimum design capacity of 0.2 cubic meter per person a year. The recommended design for future installations of DVC toilets in Tanzania, however, has a working volume of 0.88 cubic meter per vault, equivalent to a design capacity of 0.3 cubic meter per person yearly if it is to serve a family of six for six months.

Alternatively, in areas with a high water table, a series of shallow vaults may be constructed (on a plinth, if necessary), over which a portable superstructure may be moved on a schedule that ensures that excreta remains sealed for at least one year before being removed and used.

The destruction of all excreted pathogens cannot be expected to occur within six months at vault temperatures below 40°C. If the alternating cycle of vault usage is increased to one year, then only a few viable *Ascaris* ova will remain. It is therefore recommended that the vault cycle be taken as one year and the design capacity as 0.3 cubic meter per person yearly. Then the vault volume V (in cubic meters) is given

by the equation:

$$\begin{aligned} V &= (1.33)(0.3)P \\ &= 0.4P, \end{aligned}$$

where P is the number of people using the toilet. The factor 1.33 is introduced since the vault is taken out of service when it is three-quarters full.

Material and labor requirements

Construction material and labor requirements are generally comparable to those for VIP latrines and ROEC's, providing special care is given to making the vaults weather resistant. Separate urine channels may be needed to improve nitrogen recovery, reduce supplemental carbon requirements, and reduce moisture content.

Complementary investments and water requirements

Sullage disposal facilities are required (see chapter 20 for more detail).

A small quantity of water is required to clean the squatting plate. Only the absolute minimum of water should be added to DVC toilets.

Maintenance requirements

Batch composting or DVC toilets require a great deal of user care and maintenance. Ash and easily biodegradable organic wastes such as sawdust, grass, and vegetable wastes must be added regularly in the correct quantities (determined by trial and error, with seasonal adjustments as required) to maintain a suitable carbon-nitrogen ratio in the composting material. Where such material is not available, composting toilets are not ordinarily recommended. Ash is often added to control odors, moisture, and flies. Care must be taken to exclude water. Finally, the vaults must be properly sealed with earth when they are three-quarters full, the other vault emptied and put into service, and its contents reused on the land.

DVC toilets are relatively easy to build on a self-help basis, and municipal authorities are generally only required to supervise their design and construction and to organize appropriate forms of credit for the smallholder. A continuing long-term and vigorous program of user education, however, will normally be necessary to ensure that DVC toilets are used correctly.

Factors Affecting Suitability

DVC toilets are not suitable in areas where:

- Sufficient user care cannot be reasonably expected
- There is insufficient organic waste material available
- The users are unwilling to handle the composted humus
- There is no local use or market for the humus produced.

DVC toilets may be unsuitable in high-density areas where users are not motivated to produce good humus for agricultural use, or are unable to obtain complementary waste materials to regulate the moisture and carbon content of the vault contents.

Health aspects

Vault ventilation reduces odor and fly nuisance, and if the squatting plate is kept clean, DVC toilets do not pose significant risks to health. Provided each vault can store excreta for one year at ambient temperatures (see Figure 15-1), the composted humus can be safely handled and used on the land because only a few viable *Ascaris* ova will be present.

Costs

The total cost of DVC toilets built as part of pilot projects in Africa ranged from \$150 to over \$550. It is likely, however, that a typical DVC toilet with a modest superstructure could be built for \$100 to \$300. Operating and maintenance costs would be

negligible if the household removed the compost for its own use. If the municipality collected the compost and transported it for use, the operating costs could be significant.

Potential for upgrading and resource recovery

There is usually no need to upgrade DVC toilets. They can, however, be converted to PF toilets if desired and if the soil is sufficiently permeable. Their conversion to sewerer PF toilets is straightforward since they have two vaults, one of which can be used for excreta and the other for sullage. This conversion may be necessary if the housing density increases substantially so that the land available to the householders on which they can reuse their excreta decreases and on-site sullage disposal is therefore no longer possible.

DVC toilets are specifically designed for resource recovery.

Advantages and disadvantages

DVC toilets have the following advantages:

- The production of a stable, safe humus—a benefit particularly in societies where there is a tradition of reusing excreta in agriculture
- Minimal water requirements.

They have the following disadvantages:

- An extremely high degree of user care and motivation is required for satisfactory operation.
- Substantial quantities of biodegradable organic matter must be locally available.
- They are unsuitable for high-density areas.

12

PF Toilets

PF TOILETS have water seals beneath the squatting plate or pedestal seat and are available in many different designs. Two basic types are shown in figure 12-1: the direct discharge and the offset pit. They can be used for several levels of sanitation service.

PF Toilet Design

The first type is a modification of the pit latrine in which the squatting plate is provided with a simple water seal. Approximately 1 to 2 liters of water (or sullage) are poured in by hand to flush the excreta into the pit. This PF toilet is often used with wet pits since the water seal prevents odor development and mosquito breeding. It is especially suitable where water is used for anal cleansing.

The second type of PF toilet, which is widely used in India, Southeast Asia, and some parts of Latin America, is used in combination with a completely offset pit. The PF bowl is connected to a short length (8 meters maximum) of 100-millimeter-diameter pipe that discharges into an adjacent pit. Approximately 1 to 2 liters of water are required for each flush. The slope of the connecting pipe should not be less than 1 in 40.

The pit is designed as described in chapter 10 for wet VIP latrine pits and is provided with a concrete or ferrocement cover slab and wall lining as necessary. Because the digestion of excreta solids proceeds more rapidly in wet than in dry pits, a design capacity of 0.04 cubic meter per person yearly can be used. The volume (V) of pits less than 4 meters deep may be calculated from the equation:

$$V = 1.33 CPN,$$

where C = pit design capacity (in cubic meters per person yearly, or 0.06 for dry pits); P = number of people using the latrine; and N = number of years the pit is to be used.

This PF toilet may be installed inside the house since it is free from both odors and fly and mosquito nuisance; it therefore obviates the need for a separate external superstructure, and it can thus meet social aspirations for an "inside" toilet at low cost. Wherever space permits, two pits should be built. When the first pit is full, the PF unit can be connected to the second pit. When the second pit is nearly full, the first one can be emptied and the toilet again connected to it. A PF toilet with alternating pits can be used almost indefinitely.

This second type of PF toilet can also be connected to a septic tank (see chapter 14) and hence to a soakaway drainfield or sewer as shown in figure 12-2. Alternative designs for superstructures and squatting plates and designs for pits and soakaways are discussed in chapters 8 through 10.

Material and labor requirements

Material and labor requirements for PF toilets shown in figure 12-1 are similar to those for VIP latrines and ROEC's (figures 10-2 and 10-4). Rather more skill, however, is required to make the water-seal units, and this would normally be beyond the scope of individual householders on a self-help basis. The manufacture of water-seal units is, however, with experience, not a difficult task and one that readily lends itself to local enterprise. In areas where sitting is the preferred position for defecation, the "Colombian" pedestal is suitable (see figure 9-7B); this too is readily amenable to local enterprise.

Complementary investments and water requirements

Sullage disposal facilities are required for the non-sewered PF toilet (see chapter 20).

Assuming that flushing only takes place when stools are passed and that a maximum of three stools

Figure 12-1. *Alternative Designs for PF Toilets*
(millimeters)

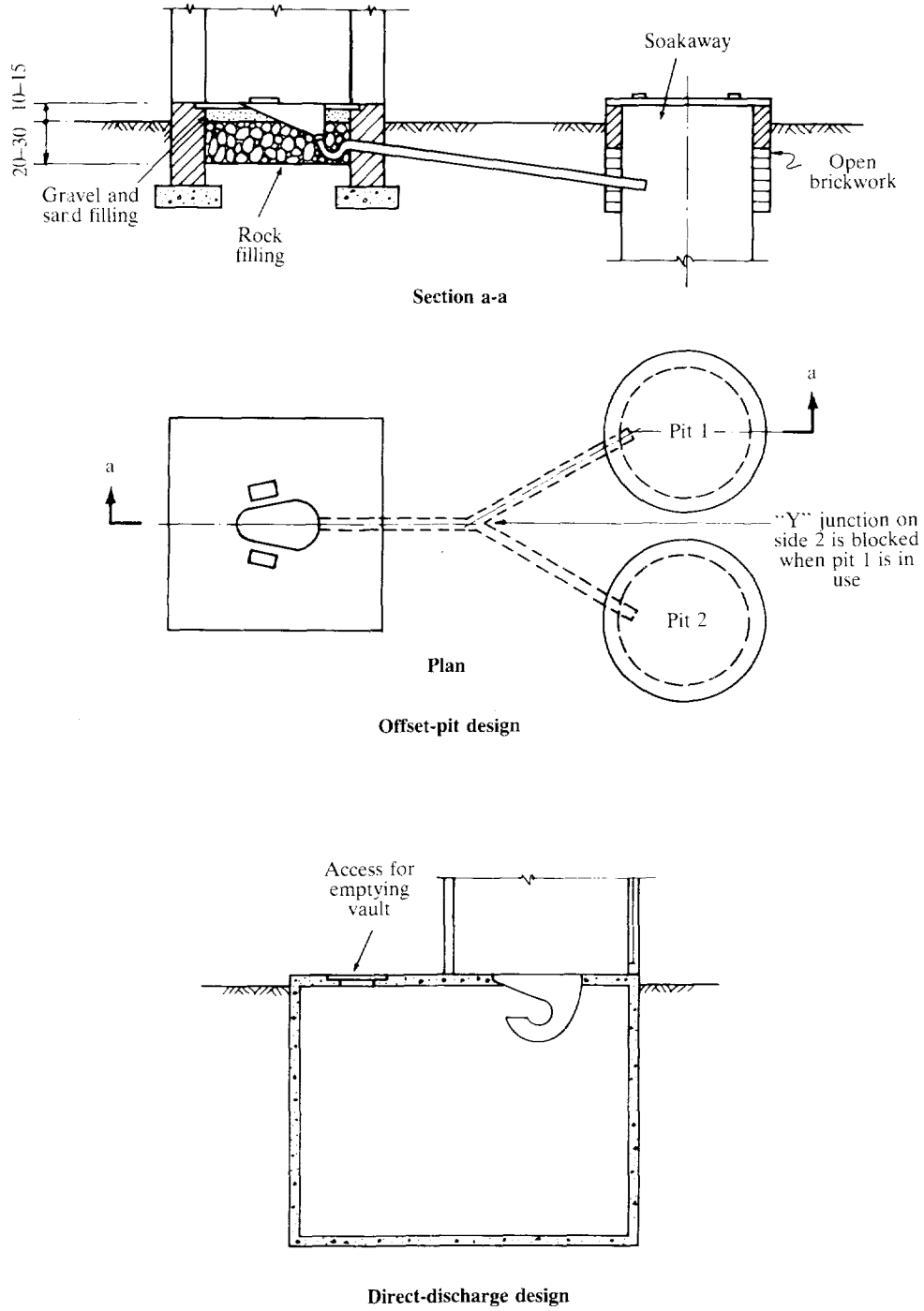

Note: In the offset pit design, the pit is placed at site of "Y" junction if only one pit is installed.

are passed per person daily, the maximum water requirement is 6 liters per capita daily.

Maintenance requirements

The householder is required to ensure an adequate supply of flushing water throughout the year. Otherwise, the maintenance requirements are as described for VIP latrines.

Factors Affecting Suitability

In general, PF toilets are subject to the same constraints as VIP latrines and ROEC's. They have the additional constraint of a water requirement of 3 to 6 liters per capita daily.

Health aspects

If properly used and maintained, toilets are free from fly and mosquito nuisance and provide health benefits similar to cistern-flush toilets.

Costs

The cost of the PF toilet is similar to that of the VIP latrine or ROEC, with the additional cost of the water-seal unit. Thus, its total construction cost should be in the range of \$75 to \$225. Maintenance costs of the system would be minimal, but flushing water requirements would probably add \$3 to \$5 per year for the household in water-scarce areas.

Potential for upgrading and resource recovery

PF toilets can be easily upgraded to a low-cost sewerage system that also accepts sullage. The necessary design modifications are discussed below. Since the manual PF system can also be eventually replaced by a low-volume, cistern-flush unit, PF toilets can be fully upgraded to sewerage cistern-flush toilets. The drainage arrangements are different from those for conventional sewerage cistern-flush toilets, but the differences are of no importance to the users, who perceive only that they have a cistern-flush toilet.

The pit contents may be used as humus, as described for the VIP latrine. If only one pit is used, however, the material removed from it should be treated by aerobic composting or by storage (for example, burial) for at least a year before reuse to reduce pathogens to an acceptable level.

Advantages and disadvantages

The main advantages of unsewered PF toilets are:

- Possible location inside the house
- No odor or fly and mosquito breeding
- Minimal risks to health
- Low level of municipal involvement
- Low annual costs
- Ease of construction and maintenance
- Very high potential for upgrading.

Their main disadvantages are that they require small but nonetheless significant amounts of water (3 to 6 liters per capita daily) and that the pit when filled must be emptied or taken out of service and a new one built. They also require separate sullage disposal facilities. They do not accept large bulky items (such as maize cobs, mud balls, and the like) used for anal cleansing; user cooperation and instruction are therefore required in areas where this is the practice.

Sewered PF Systems

The sewerage PF system is a conceptual development of the sewerage aquaprivy system that not only overcomes certain drawbacks inherent in the design concept of the latter while retaining its inherent economic advantages (see chapter 13), but also provides a more technically appropriate sanitation system in areas where the wastewater flow exceeds the absorptive capacity of the soil (see chapter 14). The sewerage PF system can be developed from an existing PF pit latrine, or it can be installed as a new facility. There are minor technical differences between these alternatives, and only the latter will be considered in this section (the former is described in detail in chapter 16).

The sewerage PF toilet system has five parts:

- The PF bowl, with a vent pipe and inspection chamber
- A short length (8 meters maximum) of 100-millimeter pipe laid at not less than 1 in 40
- A small two-compartment septic tank
- A network of small-bore sewers
- A sewage disposal facility.

A typical arrangement is shown in diagrammatic form in figure 12-2. Only excreta and PF water are discharged into the first compartment of the septic tank and only sullage into the second. The two compartments are interconnected by a double T-junc-

Figure 12-2. PF Toilet-Septic-tank Systems

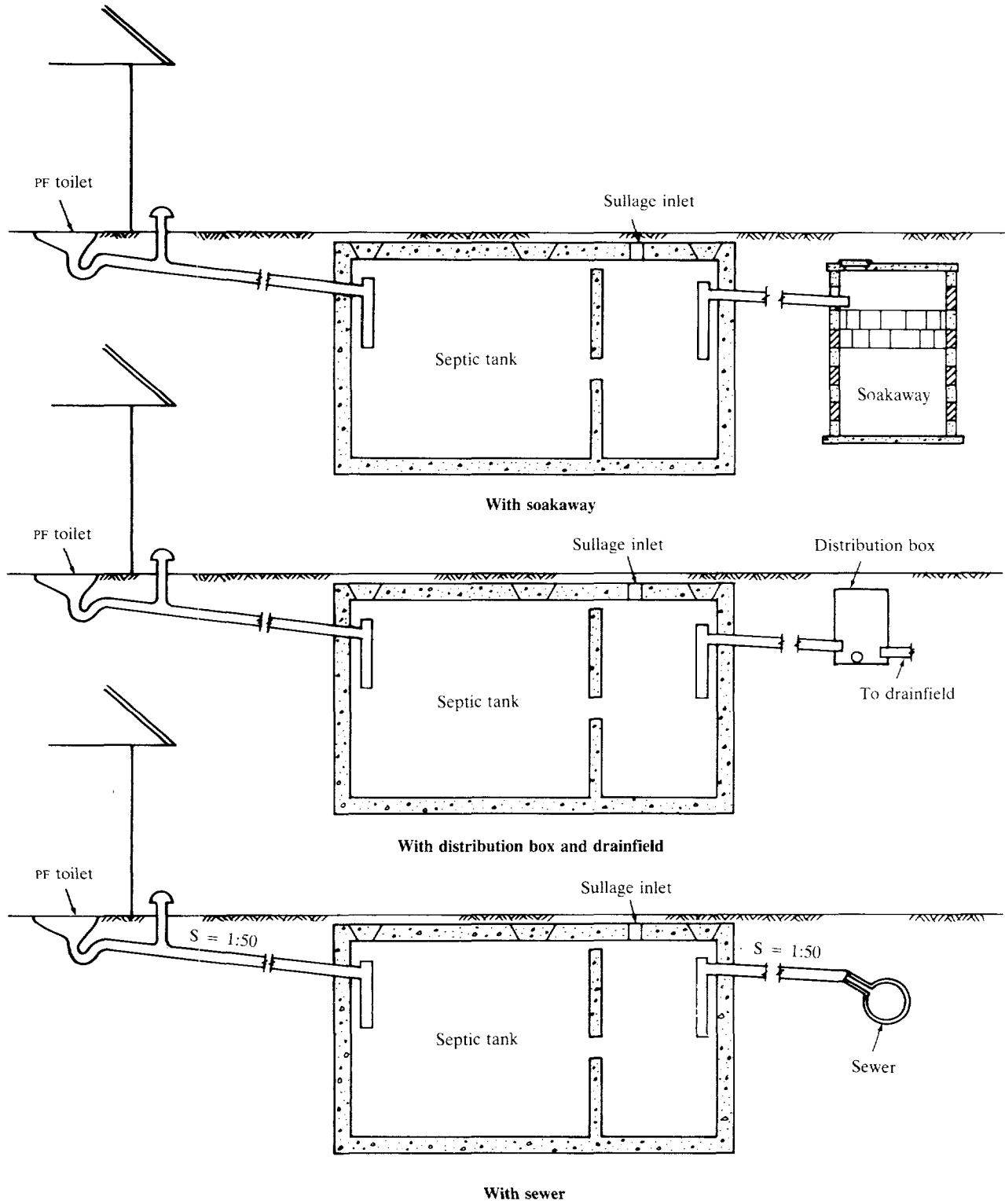

S Slope.

Note: See chapter 14 for details of septic tanks, soakaways, and drainfields.

tion, the invert of which is a nominal 30 millimeters above the invert of the exit pipe of the second compartment, which is connected to the street sewer. Thus, the contents of the first compartment are able to overflow into the second, but sullage cannot enter the first compartment. This arrangement effectively eliminates the very high degree of hydraulic disturbance caused by high sullage flows that, in single-compartment tanks, would resuspend and prematurely flush out some of the settled excreta; it thus permits a considerably higher retention time for excreta in the tank and hence is able to achieve a substantially increased destruction of excreted pathogens.

Guidelines for the size of the two-compartment septic tanks may be developed as follows. Assuming a per capita daily production of excreta of 1.5 liters and a maximum PF water usage of 6 liters per capita daily, the maximum toilet wastewater flow amounts to 7.5 liters per capita daily. Allowing a mean hydraulic residence time of twenty days in the first compartment is equivalent to a volume requirement of 0.15 cubic meter per user, which compares well with the recommendation that the first compartment should be calculated on the basis of 0.15 cubic meter per user, subject to a minimum of 1 cubic meter. The flow into the second compartment is the sullage flow and the overflow from the first compartment, or the total wastewater flow. A tank of the minimum recommended size (1.5-cubic-meter working volume) is thus suitable for up to seven users and a water consumption of 140 liters per capita daily. Desludg-

ing of the septic tank is required when the first compartment is half full of sludge, which occurs every twenty-two months, assuming a sludge accumulation rate of 0.04 cubic meter per person yearly and a capacity of 0.15 cubic meter per user.

Since all but the smallest solids are retained in the septic tank, it is not necessary to ensure self-cleansing velocities of 1 meter per second in the receiving sewers. Small-bore sewers of 100- to 150-millimeter diameter can be used, and these can be laid at flat gradients of 1 in 150 to 300. Sullage water ordinarily carries no solids that could clog sewer pipes. Consequently, manholes need only be provided at pipe junctions. Thus, the sewerer PF system achieves considerable economies in pipe and excavation cost compared with a conventional sewerage system. Taking into account these savings, the extra cost of the small septic tank, the savings in water usage, and the lower cost of the toilet fixtures, the annual economic cost of a sewerer PF system can be expected to be considerably less than that of cistern-flush toilets connected to a conventional sewerage system.¹ In addition, treatment costs will be less because of the enhanced pathogen removal and reduction of biochemical oxygen demand (BOD) (approximately 30 to 50 percent) in the septic tank.

1. The magnitude of cost savings is largely controlled by the on-site gradient. The sewerer PF system is most advantageous in flat areas in which deep excavation and pumping stations would be required for conventional sewerage.

13

Aquaprivies

THERE ARE THREE TYPES of aquaprivies: the simple or conventional aquaprivy, the self-topping or sullage aquaprivy, and the sewered aquaprivy. The second and third are simple modifications of the first to accept sullage.

The conventional aquaprivy toilet (figure 13-1) consists essentially of a squatting plate situated immediately above a small septic tank that discharges its effluent to an adjacent soakaway. The squatting plate has an integral drop pipe, 100 to 150 millimeters in diameter, the bottom of which is 10 to 15 centimeters below the water level in the tank. In this manner a simple water seal is formed between the squatting plate and the tank contents. To maintain this water seal, which is necessary to prevent fly and odor nuisance in the toilet, it is essential that the tank be completely watertight and that the toilet user add sufficient water to the tank via the drop pipe to replace any losses. A superstructure is provided for privacy, and a small vent pipe is normally incorporated in the design to expel the gases produced in the tank.

The excreta are deposited directly into the tank, where they are decomposed anaerobically in the same manner as in a septic tank. There is, as with septic tanks, a gradual accumulation of sludge (approximately 0.03 to 0.04 cubic meter per user per year), which should be removed when the tank is two-thirds full of sludge. The tank volume is usually calculated on the basis of 0.12 cubic meter per user, with a minimum size of 1 cubic meter. Desludging is normally required every two to three years. The liquid depth in the tank is usually 1.0 to 1.5 meters for individual households; depths of up to 2 meters have been used in large communal aquaprivies.

The volume of excreta added to the aquaprivy tank is approximately 1.5 liters per capita daily, and the water used for "flushing" and maintenance of the water seal is about 4.5 liters per capita daily; thus the aquaprivy effluent flow is around 6 liters per

capita daily. The soakaway should therefore be designed on this basis, although it is common to include a factor of safety so that the design flow would be, say, 8 liters per capita daily. The sidewall area of the soakaway should be calculated assuming an infiltration rate of 10 liters per square meter daily (see chapter 14).

Technical Appropriateness

Maintenance of the water seal has always been a problem with conventional aquaprivies, except in some Islamic communities where the water used for anal cleansing is sufficient to maintain the seal. Even there, however, it is necessary for the vault to remain watertight. In many other communities people are either unaware of the importance of maintaining the seal or they dislike being seen carrying water into the toilet. If the seal is not regularly maintained, there is intense odor release and fly and mosquito nuisance.

The conventional aquaprivy (figure 13-1) suffers a major disadvantage: in practice the water seal is rarely maintained. As a consequence it cannot be recommended as a viable sanitation option. Although the problem of water-seal maintenance may be overcome in both the sullage and sewered aquaprivies as shown by figures 13-2 and 13-3, and in spite of the evidence that these two systems have had success (notably in Zambia), the basic design of the aquaprivy system is questionable because of the expensive watertight tank needed to maintain the water seal. Experience has shown that the water seal may not always be maintained (usually because of failure or inadequacy of the water supply), so that the system suffers a relatively high risk of intermittent malfunction.

As shown in figure 13-2, the sullage aquaprivy is operationally equivalent to either a VIP latrine (or

Figure 13-1. *Conventional Aquaprivy*
(millimeters)

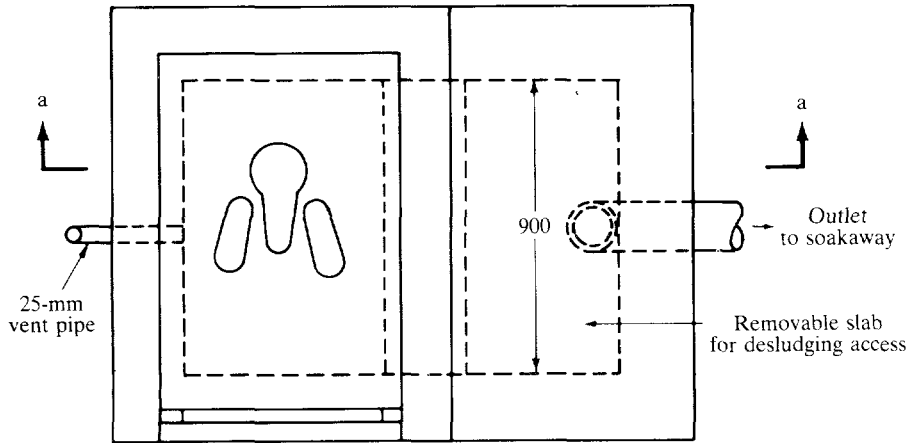

Plan

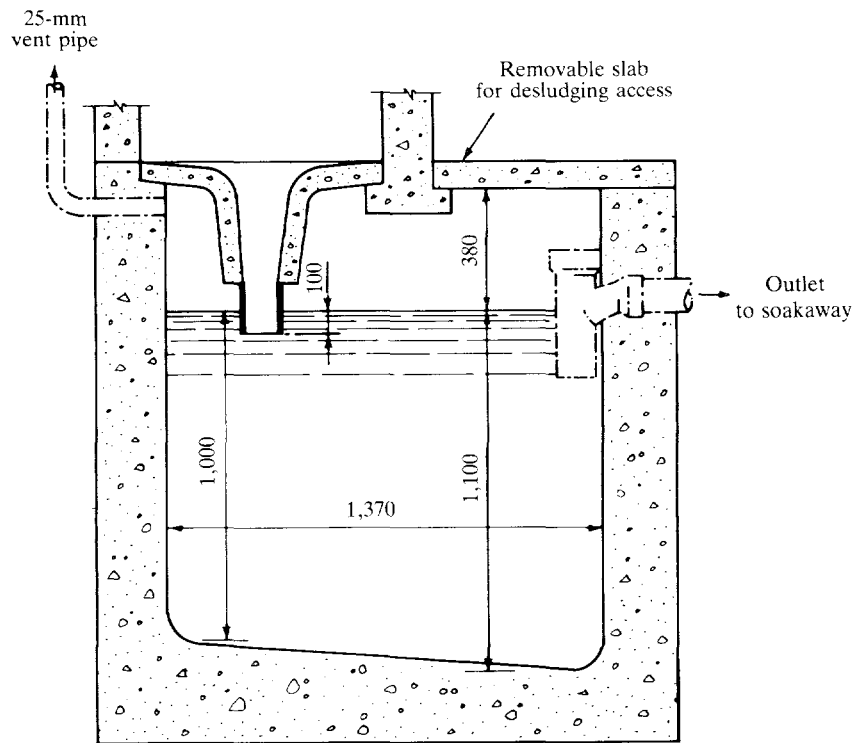

Section a-a

Source: Adapted from Wagner and Lanoix (1958).

Figure 13-2. *Formal Equivalence of Sullage Aquaprivy to VIP Latrine with Separate Sullage Soakaway or to PF Toilet*

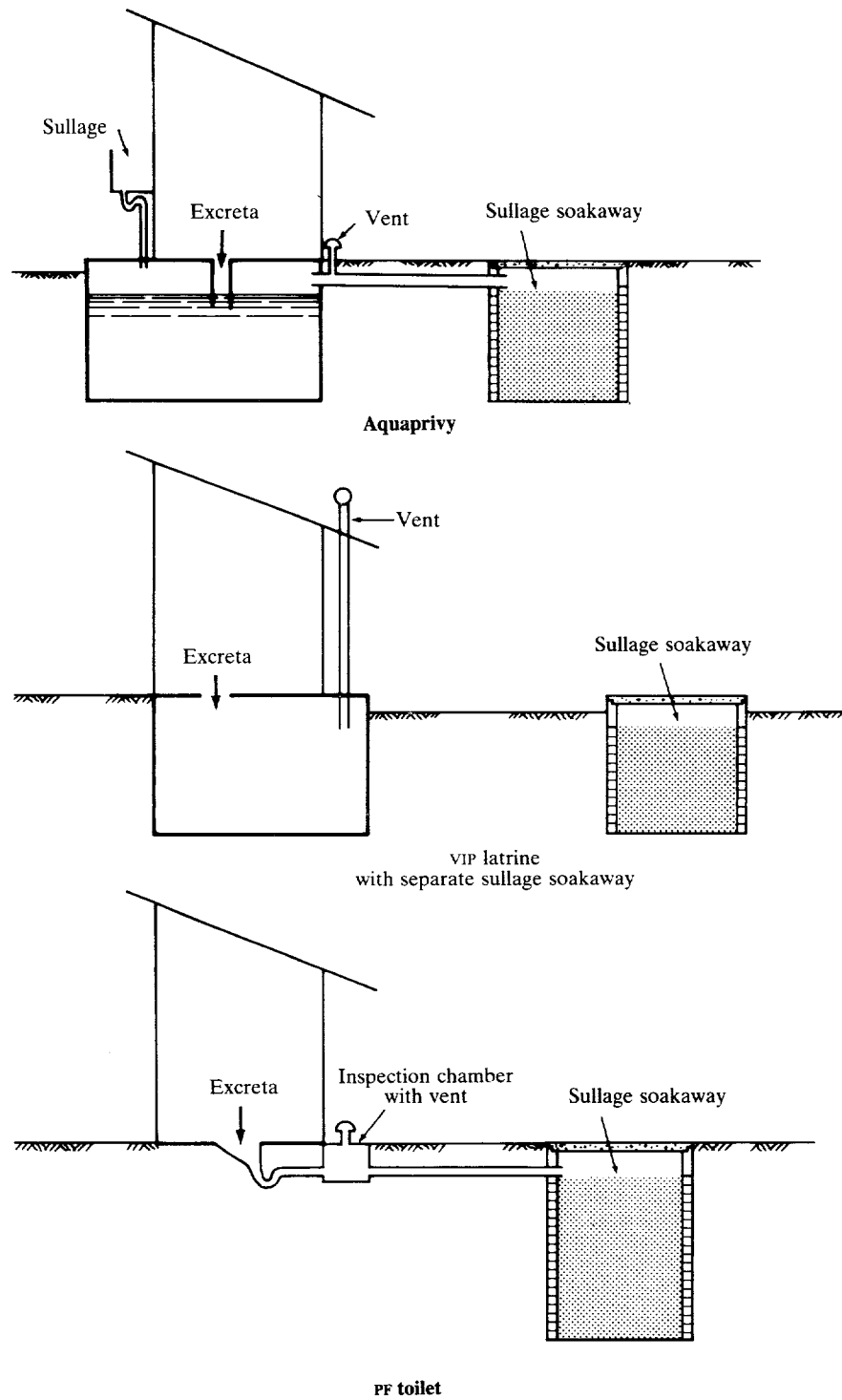
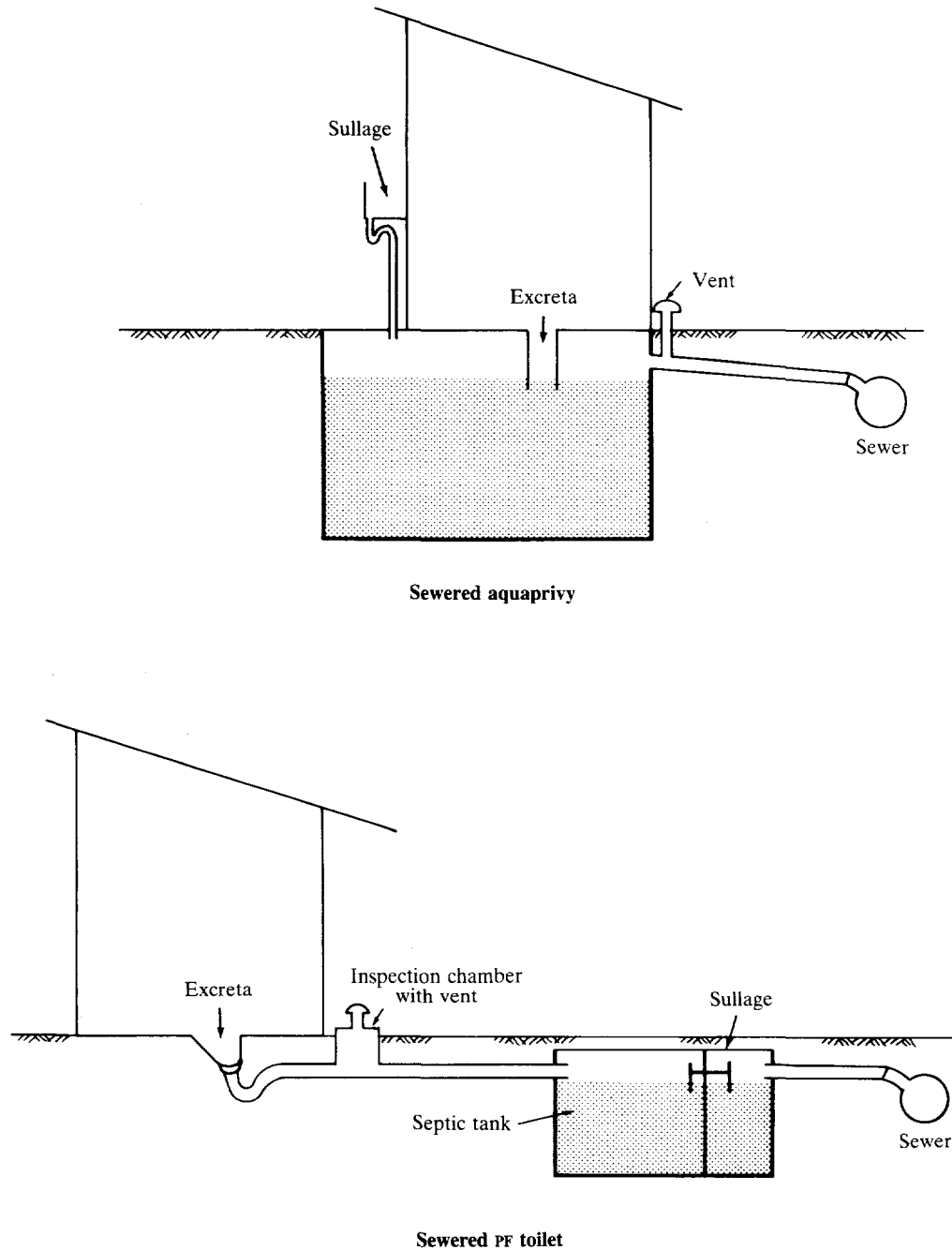

Figure 13-3. *Formal Equivalence of Sewered Aquaprivy to Sewered PF Toilet*



ROEC) with an entirely separate soakage pit for sullage disposal or a PF latrine with a completely offset pit that can also be used for sullage disposal. Either alternative costs less than the sullage aquaprivy and is superior because of reduced risks of odor and fly

nuisance and operational malfunctions. The PF toilet has a much more reliable water seal, does not require a watertight pit, can be located inside the house, and is more easily upgraded to a cistern-flush toilet.

The logic of the sewered aquaprivy system is sim-

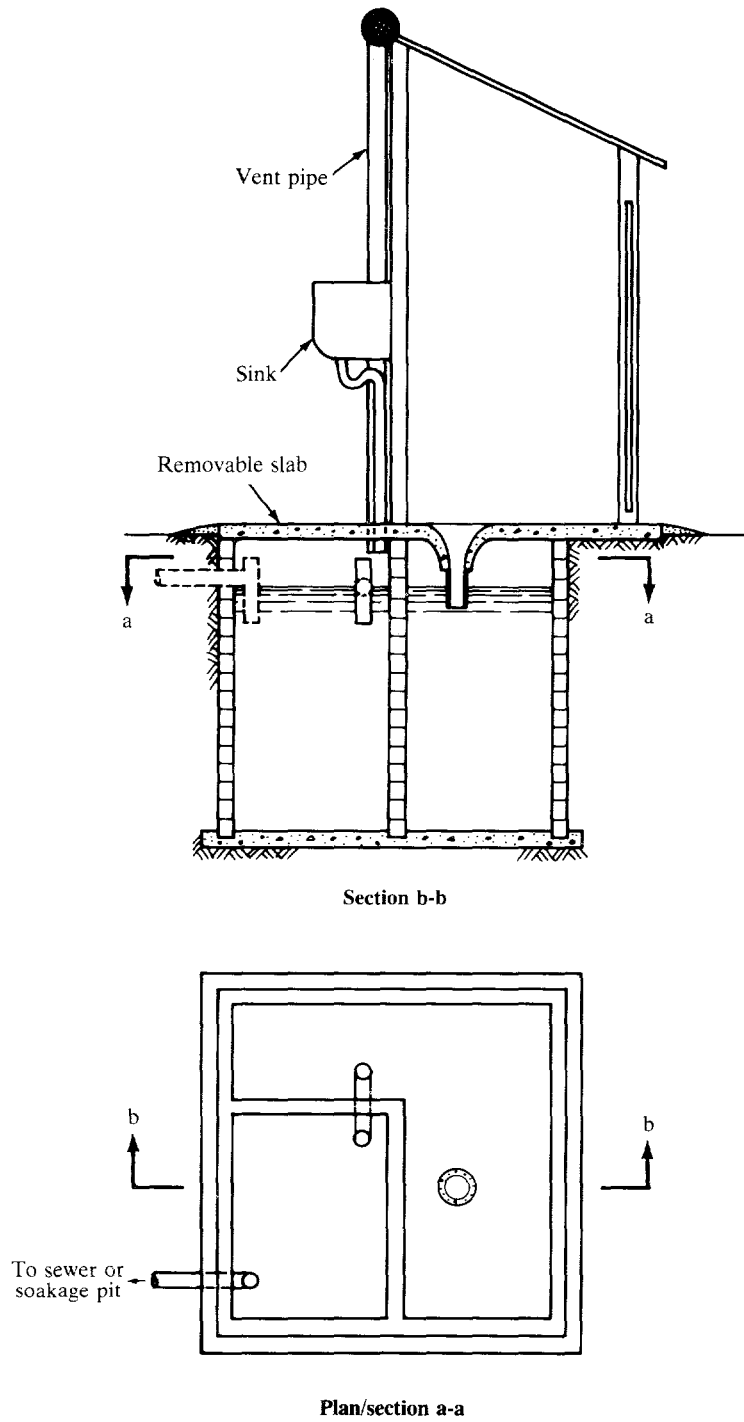
Figure 13-4. *Improved Sewered Aquaprivy with Sullage Disposal*

ilarly questionable. An aquaprivy is sewered not because of any need to transport excreta along sewers, but as a method of sullage disposal in areas where the soil cannot accept any or all of the sullage produced. As shown in figure 13-3, the sewered aquaprivy can be considered as functionally equivalent to a sewered PF toilet (see chapter 12). The sewered PF toilet is the superior system for the reasons noted above; it is also marginally cheaper.

Thus, aquaprivy systems ordinarily cannot be recommended as a viable sanitation option since they can be replaced by technically superior systems at lower cost. One important exception to this, however, is found in areas where the common anal cleansing materials (such as maize cobs, mud balls, and the like) would clog the water seals of PF toilets. In such cases the improved aquaprivy design shown in figure 13-4 should be used.

Self-topping or Sullage Aquaprivy

The self-topping or sullage aquaprivy was developed to overcome the problem of maintenance of the water seal. In this simple modification of the conventional system, all the household sullage is added to the tank; the water seal is thus readily maintained and the sullage is conveniently disposed of. Although the sullage can be added to the tank via the drop pipe, it is more common, and for the user more convenient, for it to be added from either a sink inside or immediately outside the toilet or from one located in an adjacent sanitation block. Naturally, as the volume of water entering and leaving the aquaprivy tank is increased by the addition of sullage, the capacity of the soakage pit must be increased to absorb a larger flow. Sullage aquaprivies cannot, therefore, be used in areas where the soil is not suitable for soakaways or where the housing density or water usage is too high to permit subsurface percolation for effluent disposal (unless the aquaprivy tank can be connected to a sewer system). Since all but the smallest solids are retained in the aquaprivy tank, the sewers can be of small diameter and laid at the nominal gradients necessary to ensure a velocity of around 0.3 meter per second rather than the self-cleansing velocity of 1 meter per second required in conventional sewers transporting raw sewage. Commonly, 100- to 150-millimeter pipes are used at a fall of 1 in 150 to 300. Substantial economies in sewer and excavation costs are thus possible, and sewered aquaprivy systems are therefore considerably less expensive than conventional sewerage.

Tank Design

The principal modification to the standard aquaprivy tank is the addition of a sullage compartment provided to avoid hydraulic disturbance of the settled excreta in the main part of the tank. The invert of the pipe connecting the two compartments is a nominal 30 to 50 millimeters below the invert of the effluent pipe from the sullage compartment (which leads to the soakage pit or sewer), so that the sullage flow can be used to maintain the water seal in the main compartment but is unable to resuspend the settled excreta. Since the proportion of excreta in the effluent is considerably less than that in the effluent from conventionally designed aquaprivy tanks, the soakage pit can be smaller as the infiltration rate of the effluent (now mostly sullage) is greater, approximately 30 to 50 liters per square meter of side-wall area per day. Thus, sewers may not be required because soakage pits can be used for much larger wastewater flows.

The tank volume is calculated to provide 0.12 cubic meter per user in the settling compartment, which should have a minimum size of 1.0 cubic meter. The sullage compartment should have a volume of about 0.5 cubic meter.

Material and labor requirements

The aquaprivy vault may be constructed of brick, concrete, or concrete block and must be water-proofed with a stiff mortar. The smaller units may be prefabricated of plastic, if economically feasible.

Self-help labor is suitable for excavation work, but the vault construction requires skilled bricklayers.

Complementary investments and water requirements

Aquaprivies require sullage piping to the vault and effluent piping with either an on-site infiltration facility (drainfield, soakage pit, or the like) or off-site sewerage (small-bore or conventional sewers).

Water required to maintain the water seal depends on local climatic conditions. In the sullage aquaprivy, the amount of sullage water discharged to the privy is sufficient to maintain the water seal, provided all sullage water is drained to the vault. In practice this means that, wherever sullage water is used to irrigate a garden, self-topping aquaprivies are not recom-

mended unless water is piped to the house or yard—or the users are made aware of the need to maintain the water seal.

Maintenance requirements

Maintenance is simple. The aquaprivy should be kept clean and the vault desludged at two- to three-year intervals. An adequate supply of water is necessary for “flushing” and to maintain the water seal.

Factors Affecting Suitability

Only self-topping aquaprivies should be used and only where a water seal is desired and users have traditionally used bulky anal cleansing materials that would clog a PF toilet. Water is required on-site (yard or house connection) to ensure that enough water is available to maintain the water seal.

Health aspects and costs

Properly used and maintained, the self-topping aquaprivy provides health benefits equivalent to those offered by the cistern-flush toilet.

Costs of the self-topping aquaprivy can be expected to be higher than either pit latrines or PF toilets because both a pit and a percolation unit are needed. The range of construction cost may be \$150 to \$400. Maintenance costs would be minimal, although the cost of water could easily reach \$5 or more per year in water-scarce areas. Added to this

would be the cost of either the householder’s or the municipality’s emptying the pit every three years.

Potential for upgrading and resource recovery

Self-topping aquaprivies can easily be upgraded to low-cost (small-bore) sewerage in the manner described for upgrading PF toilets. Similarly, the squatting plate could be replaced by a cistern-flush unit discharging into the vault.

Material removed from the pit should be treated by aerobic composting or stored for twelve months before use to lower health risks to an acceptable level.

Advantages and disadvantages

The main advantages of the self-topping aquaprivy are:

- No danger of clogging by bulky anal cleansing material
- Possible location inside the house
- No odor or fly and mosquito breeding
- Minimal risks to health
- Low annual costs
- Potential for upgrading.

The main disadvantages are:

- Relatively high costs for on-site disposal
- High level of skill required for construction
- Pit emptying requires some municipal involvement
- Small but nevertheless significant amounts of water required.

14

Septic Tanks, Soakaways, and Drainfields

SEPTIC TANKS are rectangular chambers, usually sited just below ground level, that receive both excreta and flushwater from flush toilets and other household wastewater. The mean hydraulic retention time in the tank is usually one to three days. During this time the solids settle to the bottom of the tank where they can be digested anaerobically, and a thick layer of scum is formed at the surface. Although digestion and volume reduction of the settled solids is reasonably effective, some sludge accumulates, and the tank must be desludged at regular intervals, usually once every one to five years. The effluent from septic tanks is, from the viewpoint of health, as dangerous as raw sewage and so is ordinarily discharged to soakaways or leaching fields; it should not be discharged to surface drains or watercourses without further treatment. Although septic tanks are most commonly used to treat the sewage from individual households, they can be used as a communal facility for populations up to about 300.

A two-compartment septic tank (figure 14-1) is now generally preferred to one with only a single compartment because the concentration of suspended solids in its effluent is considerably lower. The first compartment is usually twice the size of the second. The liquid depth is 1 to 2 meters and the overall length-to-breadth ratio is 2 or 3 to 1. Experience has shown that, if sufficiently quiescent conditions for effective sedimentation of the sewage solids are to be provided, the liquid retention time should be at least twenty-four hours. Two-thirds of the tank volume is normally reserved for the storage of accumulated sludge and scum, so that the size of the septic tank should be based on three days' retention at start-up; this ensures that there is at least one day of retention just before each desludging operation. Sludge accumulates at a rate of 0.03 to 0.04 cubic meter per person yearly; thus, knowing the number of users, the interval between successive

desludging operations (which are required when the tank is one-third full of sludge) is readily calculated.

Figure 14-2 shows a variety of alternate designs, including an experimental septic tank in which an anaerobic upflow filter is substituted for subsurface systems for effluent disposal. Reports of initial research findings are promising. An eighteen-month study showed that, after ninety days' maturing of a 12- to 19-millimeter medium, intermittent flows of 40 to 60 liters per day and BOD solids removal comparable to or better than those for primary sewage treatment were achieved. Further pilot studies may result in further application of this method. Meanwhile, anaerobic upflow filters are being used for various domestic and industrial waste applications.

Effluent Disposal

Subsurface disposal into soakage pits or irrigation in drainfield trenches (soakaways) is the most common method of disposal of the effluent. The soil must be sufficiently permeable; in impermeable soils either evapotranspiration beds or upflow filters can be used, although there is little operational experience with either of these systems. For large flows, waste stabilization ponds may be more suitable (see chapter 21).

Drainfield design

The tank effluent is discharged directly to a soakaway (figure 14-3) or, with larger flows or less permeable soils, to a number of drainage trenches connected in series (figure 14-4). Each trench consists of open-joint agricultural drainage tiles of 100-millimeter diameter laid on a 1-meter depth of rock fill (20-millimeter to 50-millimeter grading). The effluent infiltrates into the soil surrounding the trench, the sidewalls of which are smeared and partially clogged during excavation. Further clogging of the

Figure 14-1. Schematic of Conventional Septic Tank (millimeters)

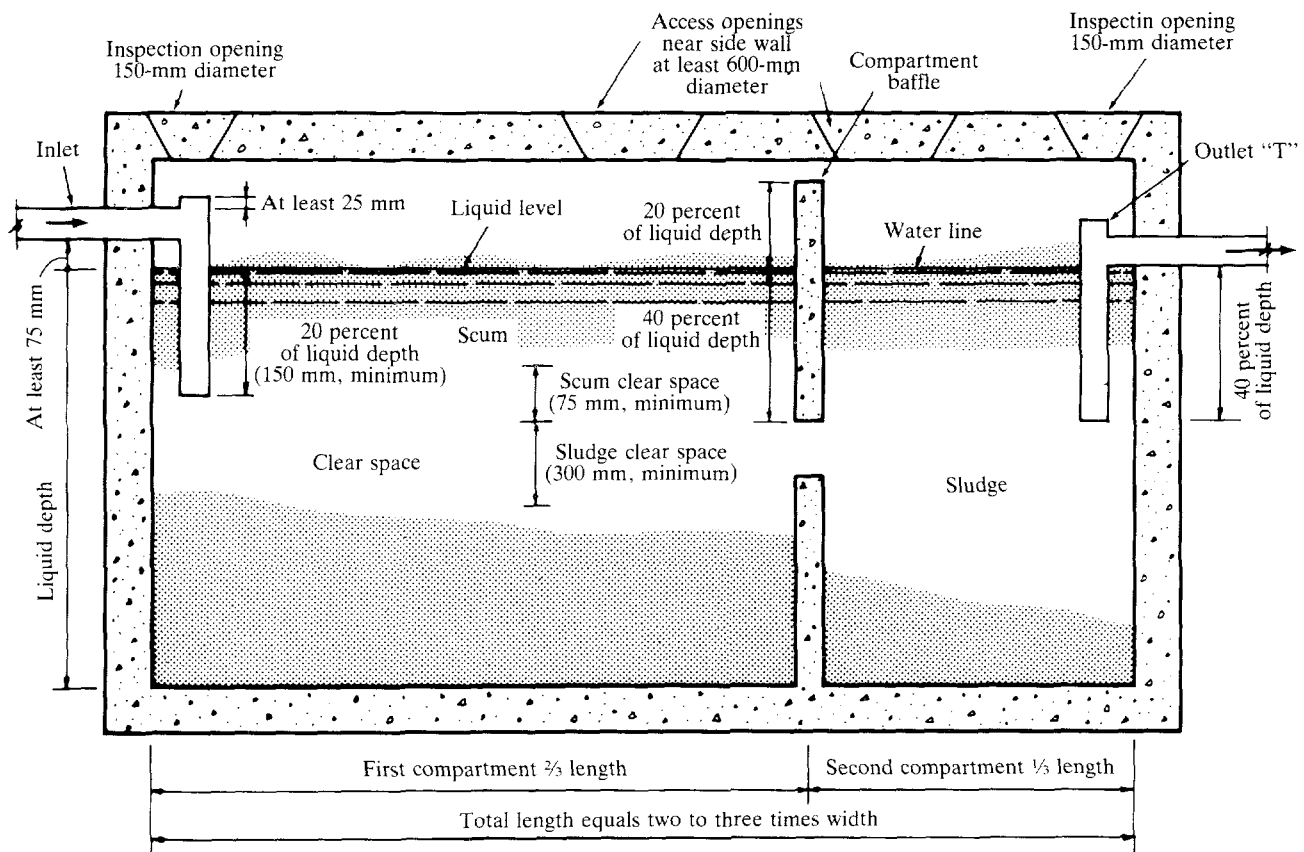

Note: If vent is not placed as shown on figure 13-2, -3, and -4, septic tank must be provided with a vent.

effluent-soil interface results from slaking (hydration) and swelling of the soil particles, from physical movement of fine solids in the effluent into the interface, from chemical deflocculation of clay particles when the effluent water has more sodium than the original interstitial groundwater, and from the formation of an organic mat made up of bacterial slimes feeding upon nutrients in the effluent. This means that the life of a drainfield is limited. Provision must therefore be made to set aside land for use as a future replacement drainfield. Soil percolation tests should be used to determine whether the soil is sufficiently permeable. The infiltration should not be estimated solely from percolation test results, however, because these merely indicate the infiltration rate of clean water into virgin soil. The infiltration rate that should be used in drainfield design is the rate at which septic tank effluent can infiltrate the soil surface that has become partially clogged with

sewage solids (which form an interface between the soil and the drainage trench). This rate of infiltration has been shown to be within the range of 10 to 30 liters per square meter of sidewall area per day for a wide range of soil types. The bottom of the trench is not considered to have any infiltrative capacity because it quickly becomes completely covered and clogged with sewage solids. The trench length required is calculated from the equation:

$$L = \frac{NQ}{2DI}$$

where L = trench length in meters

N = number of users

Q = wastewater flow in liters per capita daily

D = effective depth of trench in meters

I = design infiltration rate in liters per square meter daily.

Figure 14-2. *Alternative Septic Tank Designs*
(millimeters)

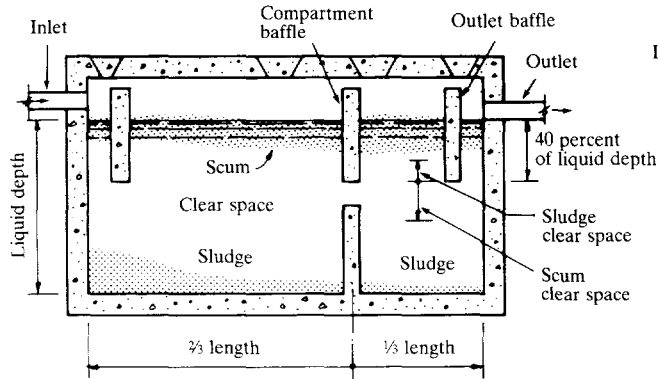

Conventional two-compartment septic tank with baffle walls

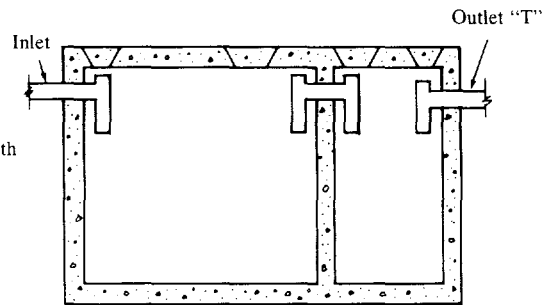

Conventional two-compartment septic tank with inlet connector and outlet "T"

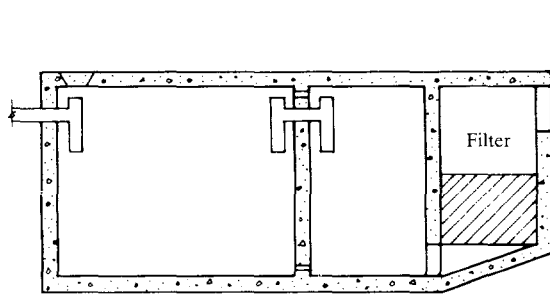

Two-compartment septic tank with upflow filter

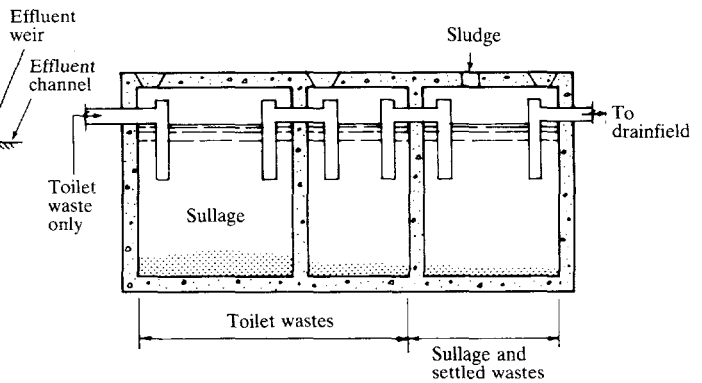

Three-compartment septic tank

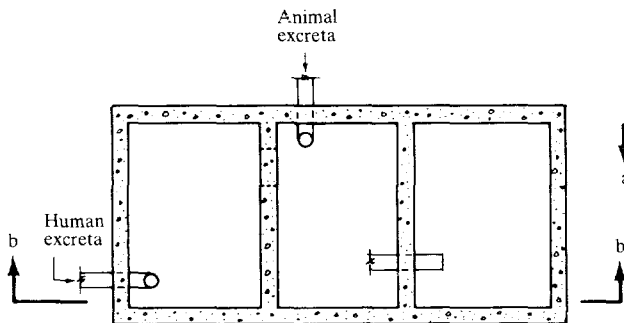

Section a-a

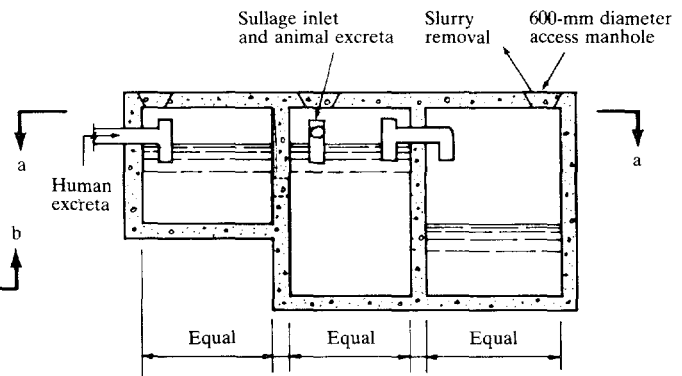

Section b-b

Three-compartment septic tank for resource recovery

Figure 14-3. *Schematic of Soakaway*
(millimeters)

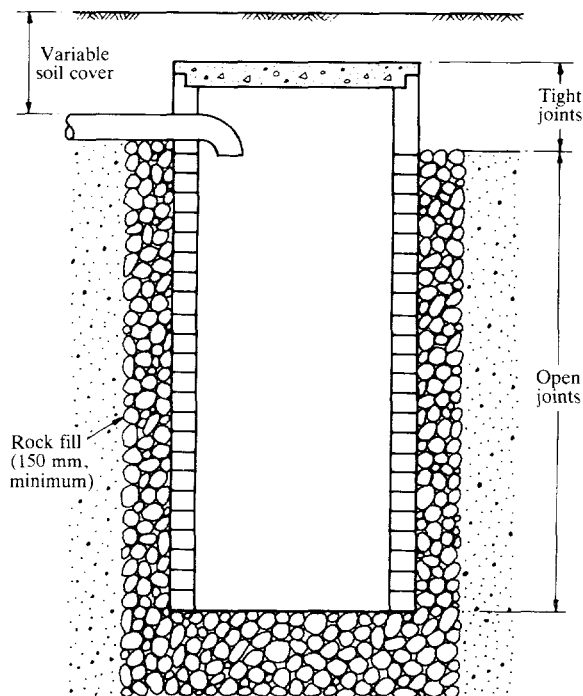

Source: Adapted after Wagner and Lanoix (1958).

The factor 2 is introduced because the trench has two sides. The design infiltration rate for soakaways or drainfields should be taken as 10 liters per square meter daily, unless a more accurate figure is known from local experience.

Soil percolation tests

The soil must have a sufficient percolative capacity, which can be determined by appropriate tests. A satisfactory field procedure is to drill at least three 150-millimeter-diameter test holes 0 to 5 meters deep across the proposed drainfield. These are filled with water and left overnight so that the soil becomes saturated; on the following day, they are filled to a depth of 300 millimeters. After thirty and ninety minutes the water levels are measured; the soil is considered to have sufficient percolative capacity if the level in each hole has dropped 15 millimeters per hour.

Location of septic tanks and drainfields

Septic tanks and drainfields should not be located too close to buildings, sources of water, or trees

(whose growing roots may damage them). Table 14-1 gives general guidelines for location in the form of minimum distances from various features.

Evapotranspiration mounds

In areas where the water table is near the surface or the soil percolation capacity is insufficient, an evapotranspiration mound may be substituted for a drainfield. Design criteria for these mounds depend on climate, soil type, and native grasses. Pilot studies are therefore required to confirm or modify the suggested dimensions in figure 14-5. In addition, gravity-fed systems require adequate slope between the septic tank outlet and the mound.

Technical Appropriateness

Septic tanks of the conventional design described above are indicated only for houses that have both an in-house water supply and sufficient land for effluent disposal. These two constraints effectively limit the responsible use of septic tanks to low-density urban areas. In such areas they are a very acceptable form of sanitation. It is all too common, however, to see septic tanks provided in medium-density areas where the effluent, unable to infiltrate into the soil, emerges onto the ground surface, where it ponds, or is discharged into street gutters or storm drains; in these cases it causes odor nuisance, en-

Table 14-1. *Minimum Required Distances from Various Physical Features for Septic Tanks and Soakaways Located in Common Well-developed Soils*
(meters)

<i>Physical feature</i>	<i>Septic tank</i>	<i>Soakaway</i>
Buildings	1.5	3.0
Property boundaries	1.5	1.5
Wells	10.0 ^a	10.0 ^a
Streams	7.5	30.0
Cuts or embankments	7.5	30.0
Water pipes	3.0	3.0
Paths	1.5	1.5
Large trees	3.0	3.0

Source: Adapted from Cotteral and Norris (1969).

a. Up to 30 meters for sands and gravels and greater distances for jointed or fissured rocks. As noted in the text, drainfields clog up and must be taken out of service periodically to permit their recovery. This is ordinarily done by adding a second drainfield, operating it to the point of refusal, and diverting the flow back to the first one. Alternatively, intermittent discharge of the septic tank effluent will tend to keep the drainfield aerobic and thus increase its operating life.

Figure 14-4. *Drainfield for Septic Tank Effluent*
(millimeters)

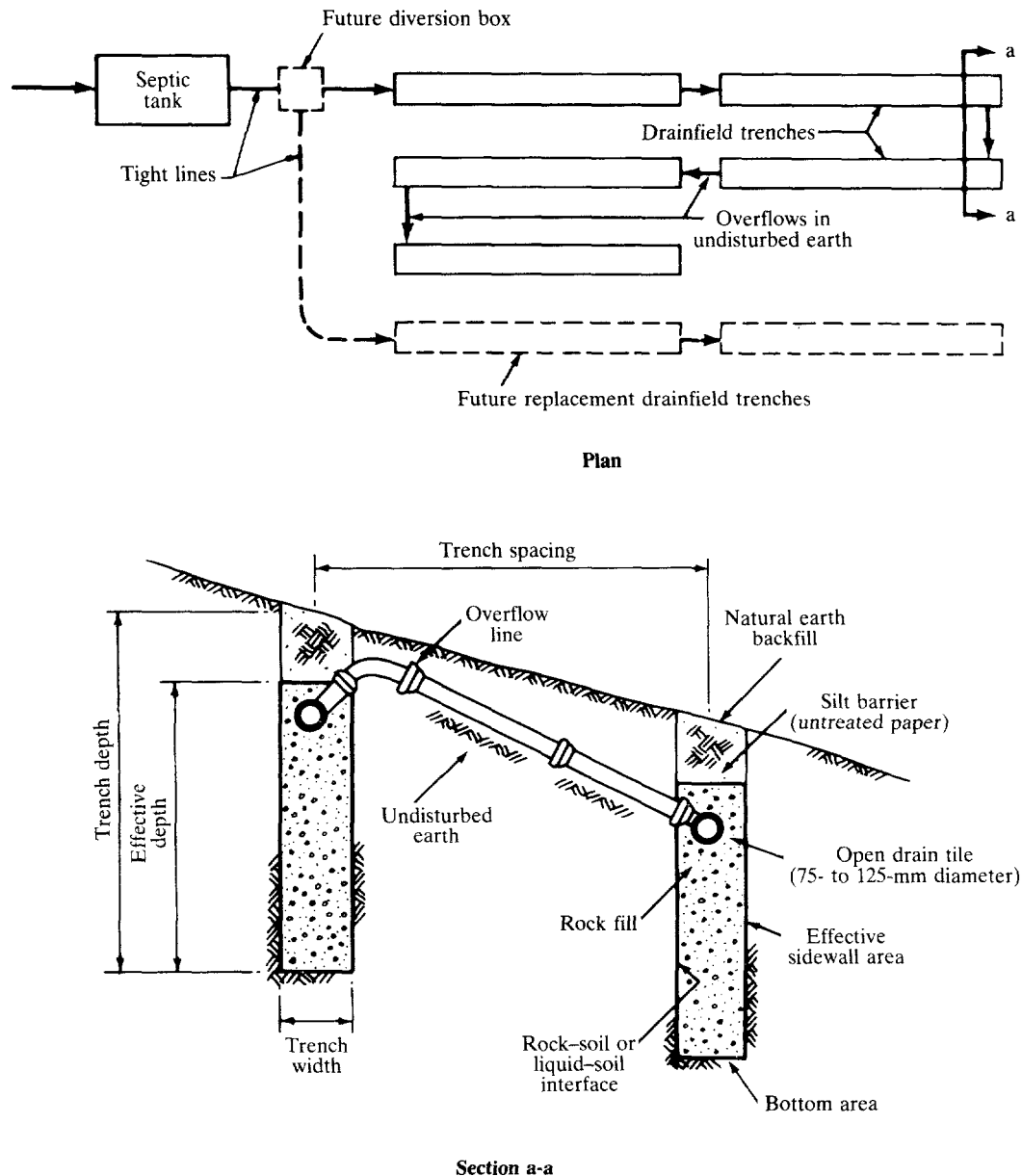

Source: Adapted from Cottrel and Norris (1969; © American Society of Civil Engineers; original used by permission).

courages mosquito breeding, and is a general health hazard.

It is possible to alter the design of the septic tank to make it more suitable for use in medium-density areas (up to approximately 200 persons per hectare). One design modification is the provision of three compartments (see figure 14-2); only toilet wastes

are discharged into the first compartment and sillage directly into the third; the second compartment provides additional and more quiescent settling for fecal solids. This arrangement avoids excessive dilution of the toilet wastes with sillage. This increases retention time and reduces the hydraulic disturbance in the first and second compartments, minimizing the

Figure 14-5. *Evapotranspiration Mounds*
(millimeters)

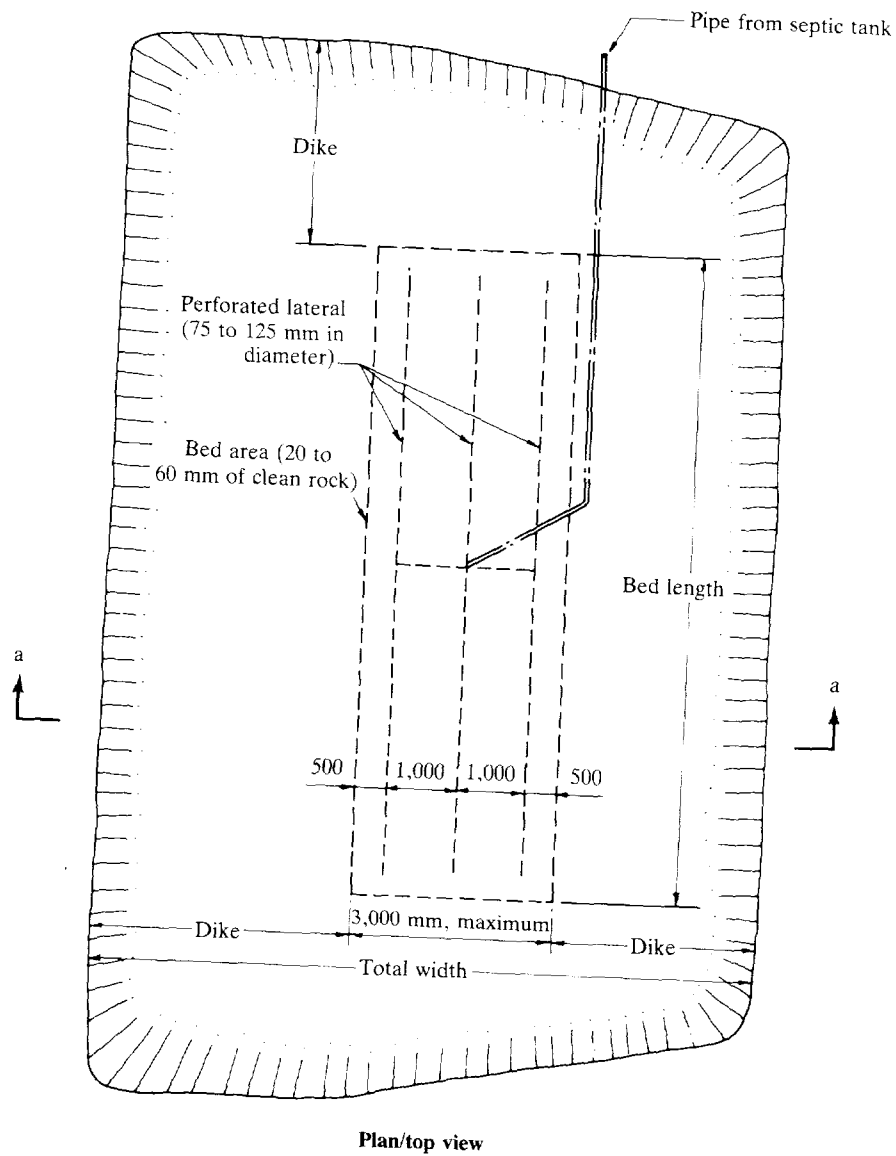
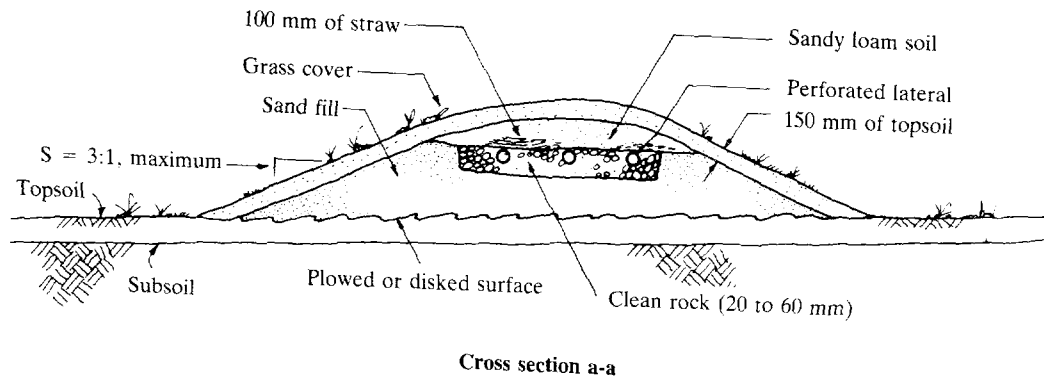

S Slope.

Note: An acceptable alternative to a mound is an evapotranspiration bed, which has the same construction but is built in a natural or manmade depression not subject to flooding and has a more or less level surface.

resuspension of settled excreta and carryover of solids into the second compartment. The third compartment acts as a sillage settlement chamber before the effluent is discharged into the drainfield. The first compartment should be designed on the basis of 0.15 cubic meter per user, so that desludging is required approximately every two years. The second and third compartments should be sized to provide one day of retention time in each. Since the effluent from the third compartment contains very few fecal solids (which are the principal cause of the clogging of drainage trenches receiving conventionally designed septic tank effluents), the infiltration rate of the effluent is much higher, approximately 30 to 60 liters per square meter daily. The trench length is correspondingly smaller, and thus septic tanks with soakaways become technically feasible, and the need for sewerage obviated, at higher housing densities than is possible with conventionally designed septic tanks. If low-volume cistern-flush (or PF) toilets and other water-saving fixtures are installed, it is possible to use septic tanks and soakaways at even greater housing densities, perhaps as high as 300 persons per hectare.

Factors Affecting Suitability

The main physical factors that affect the suitability of septic tanks are low soil permeability, restricted space for drainage fields, high water service levels, and proximity of wells that supply drinking water.

Maintenance requirements

To provide the minimum twenty-four-hour detention time in the first compartment required for proper operation, septic tanks should be inspected periodically to ensure that neither scum particles nor suspended solids are being carried out with the effluent. In any case, tanks must be desludged at regular intervals. For example, the accumulation rate of 0.04 cubic meter per capita yearly used for designing a septic tank with capacity for ten people and with a working volume of 1 meter wide, 3 meters long, 2 meters deep, and one-third of the volume to provide for sludge and scum accumulation will necessitate a pumping interval of five years.

Health aspects

In general, enteric bacteria do not survive more than 10 meters of travel through soil. Greater travel distances have been observed, but these have been

through sandy, gravelly, or fissured overburden. Therefore, if the drainfield is properly designed and located, no health hazard should result.

Costs

Septic tanks and leaching fields are among the most expensive forms of household waste disposal. Capital operation and maintenance costs have been found to exceed costs of conventional sewers and sewage treatment by 50 percent in the United States and to be about equal to the costs of sewerage, including conventional activated sludge with effluent chlorination and sludge incineration, in Japan.¹ It must be noted, however, that these costs are derived from installations where high water consumption prevails and none of the improvements recommended herein had been applied.

Potential for upgrading and resource recovery

PF or cistern-flush toilets with septic tank systems are readily connected to small-bore or conventional sewerage systems. The conversion is often required when water use and/or population density exceed limiting characteristics of the soils in which the drainfields are placed.

The three-compartment septic tank was specifically designed and operated for recovery of fertilizer from human and animal excreta and is particularly popular in rural areas of China. Excreta and the required flushwater are discharged via a PF bowl (or, alternatively, via a straight or curved chute as in a ROEC) into the first compartment of the septic tank. The retention time in this chamber is ten to twenty days. The contents of the first compartment overflow into the second, to which may also be added animal excreta (usually of pigs) from an adjacent animal pen. The retention time in the second compartment is also ten to twenty days; allowance has to be made for the additional daily volume of animal wastes. The third compartment, which receives the effluent from the second, is a storage tank for treated excreta with a holding capacity of twenty to thirty days. The contents of the third compartment are removed for use as liquid fertilizer on agricultural crops; alternatively, they could be used to fertilize fishponds.

Experience in rural China has shown that the three-stage septic tank system reduces fecal coliform counts to below 1,000 per 100 millimeters and achieves an efficiency in removing *Ascaris* ova approaching 100 percent (with at most 5 percent viability of the few remaining ova). The contents of the

third tank are reported to be relatively odorless, light brown to yellow in color, and with only finely divided suspended solids.

During the forty- to sixty-day retention time in the septic tank a high degree of excreted pathogen removal occurs; nonetheless, the final product probably will contain pathogenic bacteria, viruses, and helminths. There is no doubt that the agricultural reuse of excreta treated in the three-stage septic tank is superior to the direct use of untreated excreta. It is, however, questionable whether in many parts of the world such treatment and reuse would be socially acceptable or advisable from the viewpoint of health. The three-stage septic tank system, however, is applicable to rural areas where there is a tradition of using liquid excreta for crop or fishpond fertilization. In such areas its pathogen removal efficiency can be considerably increased by providing thirty days' retention in each compartment, with a corresponding

increase in vault volumes. The three-stage septic tank design shown in figure 14-2, which provides for increased retention and destruction and for introduction of sullage to the third chamber, is a modification of the proven Chinese design.

Advantages and disadvantages

The main advantage of septic tank systems is their flexibility and adaptability to a wide variety of individual household waste disposal requirements. Their major disadvantages include large space requirements, a reasonably high degree of user attention, and high costs.

Note to Chapter 14

1. See Kalbermatten, Julius, and Gunnerson (1982).

15

Conventional Sewerage

THIS CHAPTER represents a brief overview of conventional sewerage. It is neither an authoritative nor comprehensive treatment, nor is it intended to provide guidance to the designer of conventional sewerage systems. Those interested and requiring further information will find a wealth of publications readily available. The discussion here is intended merely to point out some of the reasons why conventional sewerage is only one of the sanitation alternatives that should be considered in communities of developing countries.

Excreta Disposal

The conventional cistern-flush toilet is basically a water-seal squatting plate or pedestal unit in which excreta are deposited and then flushed away by 10 to 20 liters of clean, potable water that have been stored in an adjacent cistern; the cistern is connected to the household water supply and is provided with a float valve so that it automatically refills to the correct volume in readiness for the next flush. The excreta and flushwater are discharged, together with all the other household wastewater (sullage), into an underground network of sewers for transport to a sewage treatment works or marine discharge station. Alternatively, in low-density areas discharge may be into a septic tank (see chapter 14).

Sewage Collection

Conventional sewerage is designed to transport a mixture of excreta and water from the house to the central treatment plant through a network of pipes. This is done in a separate sanitary sewer system that transports domestic, commercial, and institutional wastewater, although some cities have combined

sewer systems that carry both sewage and stormwater. At present, however, it is customary to build separate sewer systems rather than to provide large combined sewers, the capacity of which is only fully utilized during periods of intense rain and which are likely to have dry weather flows with insufficient velocities to transport excreta.

Sanitary sewer pipes are normally made of concrete, asbestos cement, vitrified clay, or polyvinyl chloride (PVC). They are generally designed for gravity transport of maximum (peak) flows of two and one-half to four times the mean daily flow at velocities of 0.6 to 1.0 meters per second at mean daily flow. This velocity is required to resuspend and transport solid material that may have settled during periods of lower flows and lower velocities. In areas where bulky anal cleansing materials are used or where sand is used for scouring kitchen utensils, velocities of not less than 1 meter per second are necessary to prevent blockage of sewers. Achieving scouring velocities in flat areas may require relatively steep pipe grades and expensive pumping stations to lift sewage to higher elevations.

Conventional sanitary sewer systems have many merits: they provide the greatest user convenience of all the waste disposal systems, for they permit the discharge of large amounts of water; they do not pose any risks to health when functioning properly; their maintenance is assumed by the municipality, and they generally operate with few service interruptions or emergencies. Yet sewer systems also have disadvantages: they are, first of all, very expensive to construct; they require skilled contractors for the construction, a municipal organization for operation and maintenance, and a substantial amount of flushing water, which adds to the operating costs. They are not suitable if water supply is limited because they are prone to malfunction (blockage) where total water use is less than about 75 liters per capita daily, and in hot climates concrete and asbestos-cement

pipes are subject to rapid deterioration from corrosion due to hydrogen sulfide formed in the sewer.

Given the high convenience level of sanitary sewerage, this system of excreta disposal has been the one of choice almost to the exclusion of other alternatives. Unfortunately, the usually high costs associated with the construction of such systems have virtually prevented large segments of society from obtaining benefits from this solution. Thus, a search has been underway to find ways and means to reduce the cost of sanitary sewerage and to make the system affordable for a much greater number of people. Attempts have been made to find new pipe materials, such as PVC, which have reduced the cost somewhat. So far, however, no substitute has been found for the expensive large pipes that are needed for main and interceptor sewers. Other advances made are the introduction of plastic pipes for house plumbing and connections from the house to the street main. Nevertheless, overall costs have remained high and conventional sewerage, therefore, still is beyond the financial capacity of vast numbers of poor people in developing countries.

Conventional sewage treatment

The purpose of sewage treatment is the elimination from wastes, prior to discharge to receiving waters and land, of pathogens, chemicals, organics, and other material that could have detrimental effects on human health and the environment.

A variety of unit processes are combined to form a conventional sewage treatment works. These typically consist of:

- Preliminary treatment (screening or comminution, flotation, and grit removal)
- Primary sedimentation
- Biological treatment by biofilters (trickling filters) or activated sludge process
- Secondary sedimentation
- Treatment of the sludge from the sedimentation tank (commonly anaerobic digestion and drying beds).

Tertiary treatment (microstraining, sand filters, chemical precipitation, and the like) is rarely incorporated in developing countries. Alternative processes for sludge dewatering (such as pressure filtration and centrifuging) are also rarely used in developing countries.

Conventional sewage treatment has three major disadvantages in developing countries:

- Extremely poor pathogen removal efficiencies (see below)
- Very high capital and operating costs (usually with the need to import all or much of the mechanical equipment, with a correspondingly high foreign exchange cost)
- A requirement for a very high level of operation and maintenance skills.

There are many conventional sewage treatment works in developing countries, but few of them operate satisfactorily. Most plants are not maintained properly, a problem that is often exacerbated by long delays in importing spare parts and disinfectants needed to destroy pathogens not removed by the treatment process.

Effluents from conventional treatment works (primary sedimentation, trickling filters, and secondary sedimentation) contain significant concentrations of viruses, bacteria, protozoa, and helminth ova and are thus unsuitable for unrestricted direct reuse in agriculture. Effluents may often be unsuitable for discharge to freshwater bodies where those water bodies are used for domestic water supplies by downstream populations. The minimum hydraulic retention time in the total plant may be only five hours, which largely explains why the effluent will be of poor microbiological quality even if it meets quality standards of no more than 20 milligrams per liter of 5-day biochemical oxygen demand (BOD_5) and no more than 30 milligrams per liter of suspended solids. Effluent quality may be improved by using double filtration or recirculation, but the final effluent will still be highly pathogenic. The only way to produce an effluent of reasonably good quality from a health viewpoint is by certain tertiary treatment processes.

Activated sludge effluent will be of marginally better quality than that from trickling filters but will still be heavily contaminated, regardless of its chemical quality. The minimum hydraulic retention time in the plant may be less than twelve hours, and the final effluent will contain significant numbers of all pathogens found in the raw sewage. Tertiary treatment is needed before reuse and may also be necessary before discharge into a river that downstream populations use.

The quality of the sludge depends on what treatment it receives. Fresh sludges from primary and secondary sedimentation tanks will contain pathogens of all kinds. Batch digestion at 50°C for thirteen days will kill all pathogens, at 32°C for twenty-eight days will remove protozoa and enteroviruses, and for 120 days unheated will remove all pathogens ex-

cept helminths. Sludge drying on open beds for at least three months will be very effective against all pathogens except helminth ova. Other unheated dewatering techniques will have little effect on the pathogenic properties of sludge.

Continuous digestion at 40 to 50°C may produce a sludge containing helminth ova, or containing enteric bacteria and ova if sludge drying beds are not used. All other alternatives will produce a sludge containing helminth ova, and some (such as digestion at 35 to 40°C followed by vacuum filtration) will produce a sludge containing enteric viruses and bacteria as well. Thus, no sludge digestion and drying process in common use offers any safeguard against pathogens.

The importance of temperature and time for pathogen destruction is shown in figure 15-1. From the viewpoint of health, the object of a sewage treatment works should be to retain all solids and liquids for the maximum time, to heat them to the maximum temperature feasible, or both. Batch processes are far more reliable in achieving this than continuous processes, particularly when the sludge is to be reused in agriculture. Batch digestion of municipal sludges, however, will require both seeding and from thirty to ninety days' start-up time to reach effective operating temperatures.

Numerous modifications of the activated sludge process exist. Two are mentioned below because their simplicity makes them especially attractive for application in developing countries. Aerated lagoons resemble small waste stabilization ponds (see chapter 21) with floating mechanical aerators, but they are more correctly considered as a simple modification of the activated sludge process.

AERATED LAGOONS. These will, as a result of their longer retention times, achieve better pathogen removal than that obtained in the conventional activated sludge process. In the settling pond there will be complete removal of excreted protozoa and helminth ova, although hookworm larvae may appear in the effluent, which will also contain bacterial pathogens and viruses. Schistosome larvae will be eliminated if the snail host is prevented from infesting the lagoon. The effluent can be treated in one or more maturation ponds to achieve any desired level of pathogen survival.

OXIDATION DITCHES. These are another modification of the activated sludge process: screened sewage is aerated in and circulated around a continuous oval ditch by one or more special aerators, called

“rotors,” placed across the ditch. The effluent from the oxidation ditch sedimentation tank has a pathogen content similar to that produced by the conventional activated sludge process, although, as a result of the increased retention time, slightly lower survivals are achieved.

Tertiary treatment

Tertiary treatment methods are increasingly used in Europe and North America to improve the quality of effluent produced by conventional secondary treatment works. These processes were not primarily designed for pathogen removal, but some of them do have good characteristics of pathogen removal.

RAPID SAND FILTRATION. This is perhaps the most common tertiary treatment method found in larger treatment works. High loading rates (200 cubic meters per square meter daily) and frequent backwashing (one to two days) prevent the buildup of biological activity in the filter. Some viruses will be absorbed and some bacteria retained; cysts and ova may be retained because of their size. In short, the pathogen content of the effluent may be improved, but not substantially, and probably not enough to justify the investment on health grounds.

SLOW SAND FILTRATION. Slow sand filters may be used on smaller treatment works where their low loading rates (2 to 4 cubic meters per square meter daily) cause them to occupy a large land area. Substantial biological activity builds up in the upper layers of the filter, and pathogen removal may be very high. Removals of viruses and bacteria of four orders of magnitude may be expected from a well-run unit, with viral removal a little higher than bacterial removal. Complete retention of cysts and ova has been recorded. Although slow sand filters are therefore highly effective in removing pathogens from a conventional effluent, their land requirement makes them suitable only for small treatment works.

LAND APPLICATION. This is another appropriate tertiary treatment method for small communities. Effluent is distributed over grassland, ideally at a slope of about 1 in 60, and is collected in channels at the bottom of the plot. Loadings are in the range 0.05 to 0.3 cubic meter per square meter daily. There is little or no information about this process applied in the tropics or in developing countries. If well managed, it should provide a high level of pathogen removal similar to slow sand filters. If poorly managed,

Figure 15-1. Influence of Time and Temperature on Selected Pathogens in Night Soil and Sludge

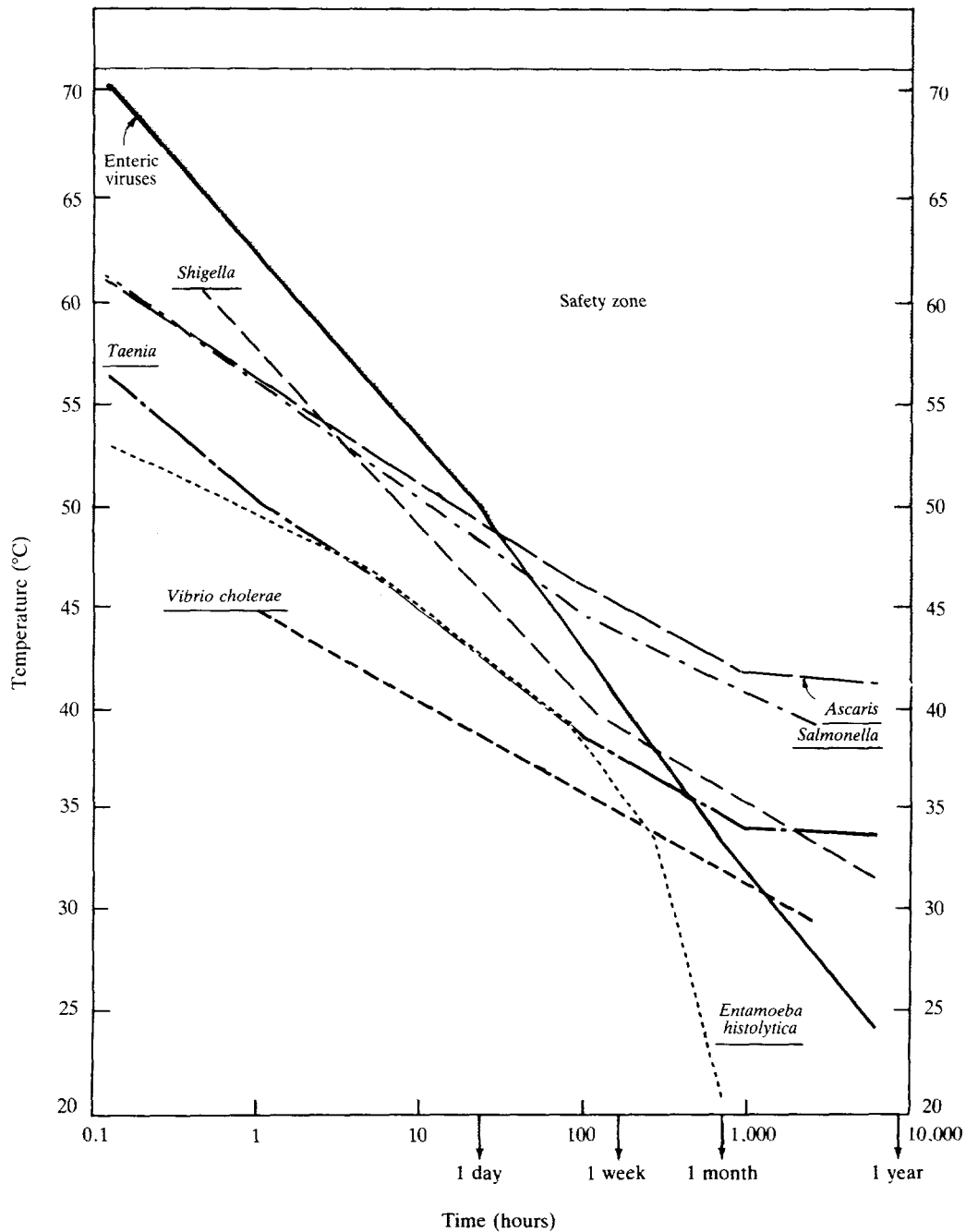

Note: The lines represent conservative upper boundaries for pathogen death—that is, estimates of the time-temperature combinations required for pathogen inactivation. A treatment process with time-temperature effects falling within the “safety zone” should be lethal to all excreted pathogens (with the possible exception of hepatitis A virus—not included in the enteric viruses in the figure—at short retention times). Indicated time-temperature requirements are at least: 1 hour at $\geq 62^{\circ}\text{C}$, 1 day at $\geq 50^{\circ}\text{C}$, and 1 week at $\geq 46^{\circ}\text{C}$.

Source: Richard G. Feachem and others, *Sanitation and Disease: Health Aspects of Excreta and Wastewater Management*, World Bank Studies in Water Supply and Sanitation, no. 3 (Baltimore: Johns Hopkins University Press, forthcoming).

it will probably lead to the creation of a foul and unsanitary bog.

MATURATION LAGOONS. Conventional effluents can be upgraded in maturation lagoons. The principles involved are exactly as described for waste stabilization pond systems. If two or more maturation ponds are used, with five to ten days' retention in each, total removal of cysts and ova will result. Very high levels of viral and bacterial removal are also achieved, and by adding sufficient ponds a pathogen-free effluent may be produced.

EFFLUENT CHLORINATION. The chlorination of sewage effluents is practiced in only a few countries (notably the United States, Canada, and Israel). Its purpose is to reduce the high pathogen content of conventional effluents, but it has a number of serious limitations.

- Chlorine has to be applied in heavy doses (10 to 30 milligrams per liter) to achieve effluent

coliform concentrations of less than 100 per 100 millimeters

- Because viruses have been found to be more resistant to chlorination than bacteria, doses of 30 milligrams per liter and above have been recommended; even at these doses, complete viral removal may not be achieved
- It is most unlikely that chlorination of effluents will be effective in eliminating protozoan cysts because these are more resistant than both bacteria and viruses
- Most helminth ova will be totally unharmed by effluent chlorination.

Thus, effluent chlorination—which is not only expensive but also exceedingly difficult to operate uniformly and efficiently—may not be particularly effective in removing pathogens from conventional effluents. In addition, it may have deleterious environmental consequences, including creation of carcinogenic chlorinated hydrocarbons.

16

Small-bore Sewers

IN THIS CHAPTER, conventional sewerage is discussed and reference is made to the various sources of information on sewer design. Small-bore sewers are described to point out the possibility of using them as an alternative in the sanitation sequence to conventional sewerage and to describe the aspects of their design and operation that are different from those of conventional sewerage.

Technical Appropriateness

The small-bore sewer system, which carries settled effluent only, is one promising possibility in the search for less expensive sewerage. The reduction in cost is possible because such a system requires fewer manholes (access to the underground pipes is primarily to remove blockages in systems that carry solids); pipe slopes can be flatter because scouring velocities to resuspend settled solids (or keep them from settling) are not necessary in a system that does not carry these solids; and pipes are laid at shallower depths because grades are flatter and because effluent is discharged from settling tanks close to ground surface.

For proper functioning, small-bore sewer systems require facilities to settle solids, usually at each household or for groups of households. Settling tanks may be septic tanks, soakage pits, vaults, or similar units. Where sullage water is discharged separately to sewers, a sand and grease trap should be provided. Where sand is used for cleaning kitchen utensils, a sand trap should be provided, even if sullage water is discharged to a common settling tank, because a sand trap can be more easily cleaned than a tank containing a mixture of sludge and sand.

Small-bore sewers are particularly suitable where on-site disposal has been practiced but cannot be continued without modification because infiltration beds are no longer adequate, clogged soakage pits cannot be rehabilitated, or the amount of sullage

water has increased to the extent that on-site disposal is no longer possible. In such situations small-bore sewers can provide relief at a lower cost than conventional sewers while providing the same level of service. They can represent, in such a case, the last stage of a planned sanitation sequence. Small-bore sewers should also be considered in the initial planning of a sanitation system in areas where anticipated water consumption or soil conditions make on-site disposal of sullage water infeasible.

Design Criteria

Design and maintenance parameters based on the few small-bore systems that exist today are summarized here for the guidance of sanitation planners. These guidelines are neither comprehensive nor final and will be modified and updated as more experience is gained. Design of a two-stage septic tank suitable for small-bore systems is described in chapter 12.

Minimum velocity and pipe size

A minimum velocity of 0.3 meter per second at peak daily flow is recommended. Some flushing of mains may be required until sufficient connections are made.

A minimum diameter of 75 millimeters is recommended for connecting mains and septic tanks, aquaprivies, or other settling tanks. Minimum main diameter should be 100 millimeters.

Minimum grades for laying pipe

The recommended minimum grades, by diameter of pipe, are:

	<i>Grade</i>
75 and 100 millimeters	1 in 150
150 millimeters	1 in 250
200 millimeters	1 in 300.

The above grades should not be used as a standard but as the minimum allowable, and greater slopes

Table 16-1. Slopes and Capacities of Circular Pipes Flowing Full

Item	Diameter of pipe (millimeters)					
	50	100	150	200	250	300
Velocity $N = 0.3$ meter per second						
Slope (meters per 100 meters)	0.373	0.148	0.086	0.059	0.044	0.034
Flow (liters per second)	0.589	2.356	5.301	9.424	14.726	21.205
Velocity $N = 0.6$ meter per second						
Slope (meters per 100 meters)	1.493	0.592	0.345	0.235	0.174	0.136
Flow (liters per second)	1.178	4.72	10.602	18.849	29.452	42.411
Velocity = 1 meter per second						
Slope (meters per 100 meters)	4.148	1.646	0.958	0.653	0.485	0.380
Flow (liters per second)	1.963	7.854	17.67	31.41	49.08	70.68
Velocity = 1.5 meters per second						
Slope (meters per 100 meters)	9.333	3.703	2.157	1.470	1.092	0.856
Flow (liters per second)	2.945	11.78	26.50	47.12	73.63	106.03

Note: Calculations are based on Manning equation with roughness coefficient of 0.011.

should be used wherever possible. In general, grades should be maintained fairly accurately. Nevertheless, and in contrast to conventional sewers, slight deviations are permissible because there are no solids that would settle out in a pipe partially filled with standing effluent.

Roughness coefficient

The adoption of an n -factor of 0.013 for vitrified clay pipe and 0.011 for PVC pipe is recommended. Table 16-1 lists capacities of sewers flowing full at various slopes; figures are based on the Manning equation using a roughness factor of 0.011. The table is provided for easy reference for the most suitable and easily handled PVC pipe. For other pipe materials, consult appropriate and easily obtainable hydraulic charts and tables.

Manholes and flushing points

Manholes or flushing points should be provided at the heads of all drains, at major branch connections, and at pipe size changes. Because small-bore sewers are usually laid at shallow depth, it is probably least expensive to construct even fewer manholes

initially and install additional manholes as necessary if a main has to be excavated to remove a blockage.

Minimum cover on pipes

The minimum cover on all pipes in roadways or areas subject to wheel loads should be 1 meter above the collar of the pipes unless special arrangements are made to protect the pipe from damage. In other situations a general minimum of 0.5 meter, subject to the nature of the terrain and the possibility of mechanical damage, is recommended.

Venting

Various methods of venting are applied to sewerage systems, but the most general method in small installations is to use the head vents on the house to provide venting conditions for the reticulation sewers. In the case of a septic tank or aquaprivy system, ventilation is provided between the vent at the outlet of the septic tank, through the air space in the tank, and through the drains to the vent on the house. If a PF privy or toilet is connected directly to the small-bore sewer system, a vent should be provided on the sewer side of the water trap.

17

Bucket Latrines

THE TRADITIONAL bucket latrine (figure 17-1) consists of a squatting plate and a metal bucket located in a small compartment immediately below the squatting plate. Excreta are deposited into the bucket, which is periodically emptied by a night-soil laborer or "scavenger" into a larger collection bucket that when full is carried to a night-soil collection depot; from there the night soil is usually taken by tanker to either a trenching ground for burial or to a night-soil treatment works.

Improved bucket systems provide satisfactory service in parts of Australia and Singapore. There full creosoted household buckets are replaced by clean ones, removed, covered, carried by truck to central stations, emptied, washed, creosoted as necessary, and returned to service. Other bucket latrine systems are widely used in Africa, the Indian subcontinent, and the Far East; in these locations buckets are generally only emptied. This traditional system is, however, an extremely poor form of sanitation, only slightly better than no sanitation at all. The following two descriptions (the first about African practice, the second about Indian) illustrate the usual unhygienic nature of the system:

The collection and disposal of night soil from bucket lavatories is usually nauseating. Although in some cases the buckets are manually carried long distances to the disposal ground, the usual practice is to empty the buckets into handcarts, each comprising an empty drum supported horizontally across two wheels; when full, the handcarts are dragged away and [the contents] either buried or emptied into a sewer, septic tank or

local depression. Only rarely are the buckets and handcarts washed after use; spillage of night soil is frequent and health hazards are alarmingly obvious. The bucket lavatories are rarely disinfected. They are almost always unhygienic, offensive and usually surrounded by insects, many of which help spread human diseases; sometimes a degree of cleanliness is unintentionally achieved by keeping poultry which devour these insects. (Canter and Englande 1970; cited in Mara 1976, p. 137.)

It is common to see a scavenger moving with a heavy load of night soil on his/her head in a bamboo basket or leaky drum, the contents trickling over the carrier. (Clare and others 1961; cited in Mara 1976, p. 138.)

Although it is possible to make several improvements to the traditional bucket latrine system (for example, by providing facilities for washing and disinfecting the buckets, and covering collection buckets with tightly fitting lids to reduce spillage), it is still in practice difficult, if not impossible, to ensure that the system is operated satisfactorily, especially so that spillage of night soil is avoided. The bucket latrine system, even if it is an improved bucket latrine system, is not a form of sanitation that can be recommended for new communities. Existing bucket latrines should be improved as a short-term measure only; in the long term they should be replaced by some other sanitation facility. Often the most appropriate replacement facility, especially in high-density areas, is the vault toilet (see chapter 18).

Figure 17-1. *Bucket Latrine and Cartage*
(millimeters)

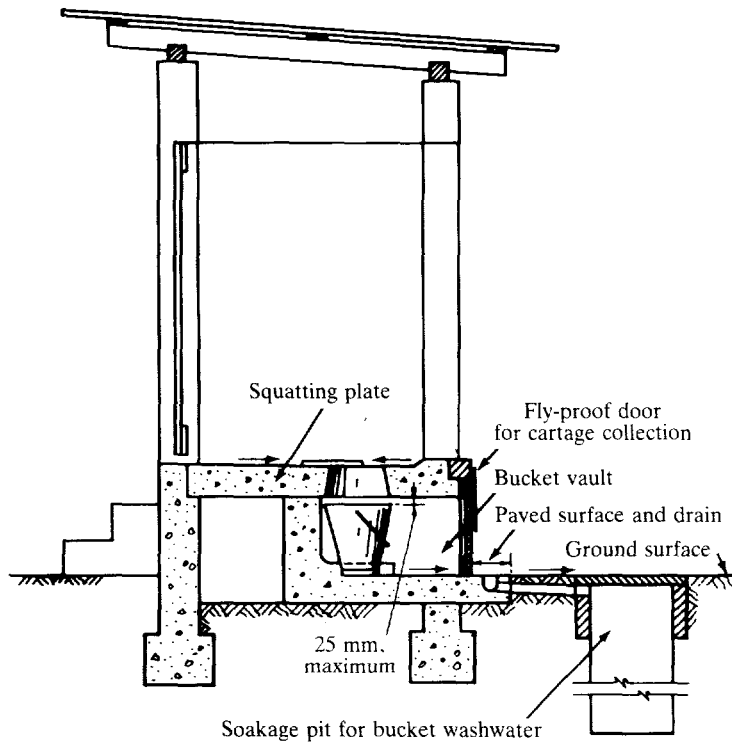

Bucket latrine

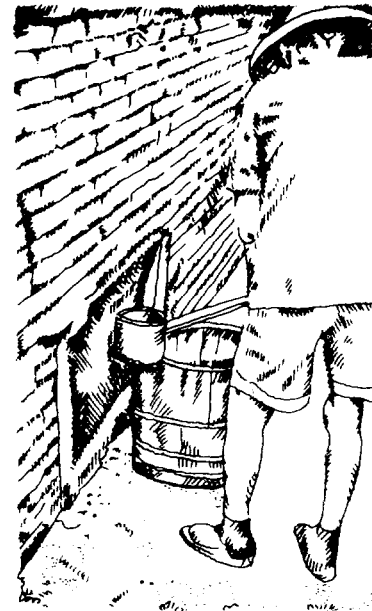

**Night-soil collection
by dipper and bucket**
(here a vault rather
than a bucket is located
in house)

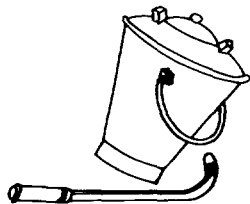

Night-soil bucket and scraper

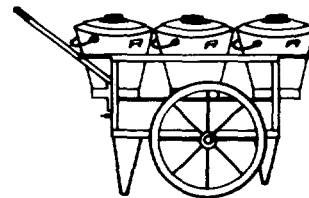

Cartage wheelbarrow for three or six buckets

Note: Fly-proof doors and paved surfaces and drains are commonly missing in most existing bucket latrines.

Sources: Top left, adapted from Wagner and Lanoix (1958); top right, from a photograph courtesy of Michael G. McGarry; bottom, Department of Social Welfare, Ahmadabad, India.

18

Vault and Cartage Systems

IN VAULT TOILETS, which are extensively used in the Far East, the excreta are discharged into a sealed vault that is emptied at regular intervals (figure 18-1). It is preferable that the vault be emptied by vacuum tanker ("vacuum truck" refers to a tank truck equipped with a suction pump), although in areas where access is difficult it may be necessary to use alternative methods (see below).

Design Criteria

The vault toilet may be installed as a PF toilet either with the vault immediately below the squatting plate or with a completely offset vault (figure 18-1). In the latter case the vault may be shared by adjacent houses, with some savings in construction costs.

The vault volume may be calculated from the following equation:

$$V = NQD/K,$$

where V = vault working volume in liters

N = average household size

Q = excreta and PF water flow in liters per capita daily

D = days between successive emptying of the vault

K = vault volume underutilization factor.

From 0.8 to 1.8 liters per capita daily of night soil are collected from vault latrines. The maximum probable amount of excreta plus PF water for vault latrines may be estimated as 10 liters per capita daily. The vault volume underutilization factor, K , is introduced since the vault will normally be emptied before it is completely full. In areas where maintenance of tanker vehicles is excellent, K may be taken to be 0.85; in other areas K may need to be as low as 0.5.

It is evident from the above equation that V and D are proportional to each other. Once vault con-

struction and emptying costs are known, it is therefore possible to minimize the total cost by optimizing the combination of vault size and emptying frequency. The vault need not be very large. For example, for a family of six using 10 liters per capita daily with a PF system that is emptied every two weeks, and with K taken as 0.5, the required vault volume is only 1.68 cubic meters, and 0.84 cubic meter of night soil must be removed each time the vault is emptied.

The tankers transport the vault contents to a trenching field, a sewer, a night-soil treatment works (see chapter 21), or a marine discharge point. If small tankers or other collection vehicles (see below) are used, the night soil can be transferred to larger vehicles for conveyance to the treatment works or discharge point.

Collection vehicles

To minimize collection costs, the night-soil collection vehicles generally should be as large as possible. Vacuum tankers usually have capacities of 1,500 to 5,000 liters, and the length of vacuum tubing that can be attached to them can be as much as 100 meters. In areas where access is difficult even this length is insufficient, and smaller collection vehicles must be used. These may be hand- or animal-drawn carts with capacities of only a few hundred liters equipped with manually operated diaphragm pumps, or small mechanically or electrically operated vehicles (even three-wheeled vehicles) fitted with mechanically operated pumps. Since vault toilet systems are so much cheaper than sewerage (see Kalbermatten, Julius, and Gunnerson 1981), it is extremely important that design engineers should consider all possible collection methods, with some site-specific improvisation as required. Access may be extremely difficult, but only very rarely will it be impossible for any sort of vehicle to be used to empty the vaults. For those

Figure 18-1. *Alternative Designs for Vault Toilets*
(millimeters)

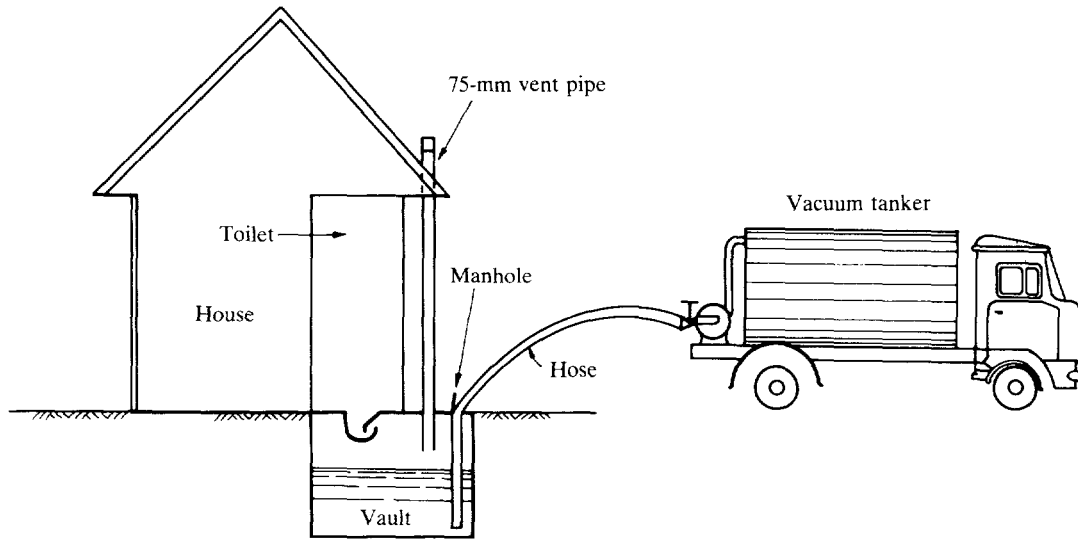

Vault below squatting plate

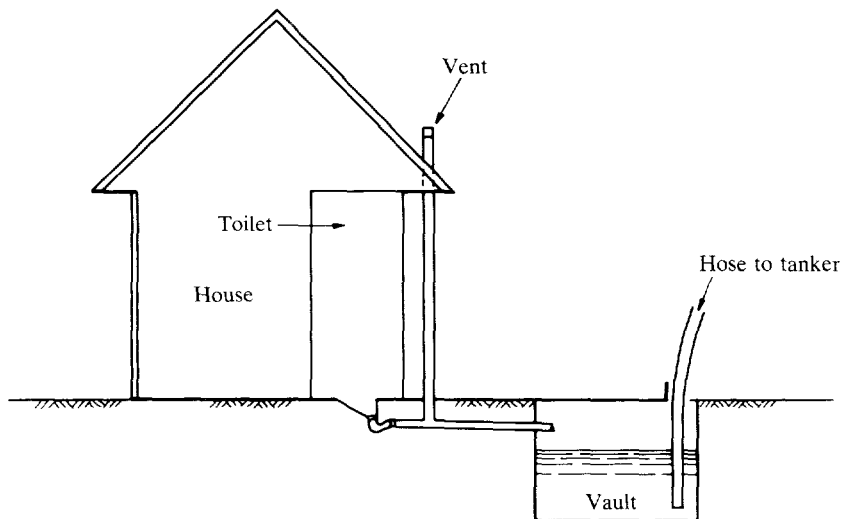

Offset vault

households where vehicle access is impossible, manual emptying of the vault by the dipper and bucket method may have to be used, although this is only a marginal improvement over bucket latrines, since some night-soil spillage is inevitable. A pipe connection to an accessible communal vault would be a preferable solution in such cases.

Material and labor requirements

The vault may be constructed from concrete, brick, or concrete blockwork suitably rendered with a stiff mortar to make it watertight; alternatively, for small vaults, prefabricated plastic tanks may be used if these are locally made and economically compet-

itive. Note that loss of water from a vault latrine (figure 18-1) may cause pumping problems. Vault contents that are more than 12 percent solids may have to be scooped or ladled. Another approach is to loosen and dilute the contents with a small amount of water (or previously diluted night soil) carried on the truck and jetted into the vault. The number of tankers (or other collection vehicles) may be estimated from the following equation:

$$N_t = 7(N_v/nD),$$

where N_t = number of tankers required

N_v = number of vaults to be serviced

v = average number of vaults that 1 tanker can service daily

n = average number of days that the tankers can be expected to be operational each week

D = the number of days between successive emptyings of each vault.

The average number of vaults that a tanker can service each day depends on the ratio of tanker size to vault size, the average time taken to empty one vault, the average time to empty and clean the tanker at the disposal point, and the collection and round-trip travel times. The average number of days that each tanker is operational each week depends on how many days per week vaults are emptied (usually five or six) and how many days per week on average are required for tanker maintenance (at least one, especially if adequate stocks of spare parts are not maintained locally); thus, in practice, n may be as low as 3 to 4 or as high as 5. If transfer stations are used, fewer collection tankers will be required. The number of transfer vehicles depends on the ratio of their size to that of the primary collection vehicles and the number of round trips they can make each day to the discharge station.

Labor requirements for vehicle operation are one driver and one laborer per tanker. In addition, tanker maintenance mechanics are required.

Complementary investments and water requirements

Facilities for the treatment and disposal of the vault contents and for sullage disposal are required (see chapters 20 and 21). In addition, adequate facilities for tanker (or other collection vehicle) maintenance must be provided.

Water is required (approximately 3 to 6 liters per capita daily) for vaults with PF toilets. In addition,

adequate tanker washwater should be available at the treatment site or at the treatment works or marine disposal point.

Factors Affecting Suitability

The vault toilet, emptied by mechanically, electrically, or manually operated tankers, is a flexible form of sanitation in which capacity can be closely matched to changes in urban land use.

Vaults are also suitable for medium-rise buildings because excreta can be readily flushed down a vertical pipe into a communal vault at or below ground level.

In most developing countries, foreign exchange is required to pay for the collection tankers or pumps. All other materials are likely to be locally available.

Health aspects

From the users' point of view, there is little difference between vault and vacuum-tanker systems and PF toilets connected to septic tanks or sewers: the only area of increased risk is the very small amount of night-soil spillage that may occur when the vault is emptied.

Cost

Since the vault is usually located inside or immediately adjacent to the house, superstructure costs may be minimal. The vault itself is relatively small, although skilled labor usually is required to ensure that it is properly sealed. The total cost of a vault with PF squatting plate, vent pipe, and superstructure is in the range of \$75 to \$200, depending mostly on superstructure costs.

The collection and treatment costs associated with vault toilets vary widely depending on the type of collection vehicle used and the type of treatment selected. Because of these factors, it is not possible to give a meaningful range of cost estimates. Operating and maintenance costs of existing systems are given in Kalbermatten, Julius, and Gunnerson (1982).

Potential for upgrading and resource recovery

Vault toilets may be converted to seweried PF toilets (see chapter 12) if at some stage in the future it is desired to improve facilities for sullage disposal or if sewer lines are laid in the vicinity.

Vault toilets have high potential for resource re-

covery: the night soil may be composted (often with domestic refuse), used for fishpond fertilization, or for biogas production (see chapter 22).

Advantages and disadvantages

The principal advantages of vault toilets are:

- Low initial costs, with system capacity closely matched to demand (trucks can easily be added as housing density increases)
- Moderate labor requirements, with consequent employment generation
- Low risks to health
- Minimal water requirements

- Possible location within the house
- High degree of planning flexibility
- Suitability for high-density areas
- High potential for resource recovery
- Minimal space requirements.

Their main disadvantages are that separate facilities for sullage disposal are required, foreign exchange is required for the collection vehicles, and a high degree of municipal involvement is required to ensure equitable service and proper vehicle maintenance. Alternatively, it may be possible to contract servicing of the vaults to private firms that have a profit incentive to operate the system satisfactorily, especially if the rights to (and profits from) resource recovery are given to the same firm.

19

Communal Sanitation Facilities

COMMUNAL SANITATION FACILITIES provide a minimum service level ranging from sanitation only to a combination of latrine, shower, and laundry units such as that illustrated in figure 19-1.

Effluent Disposal

Low-cost sewerage systems, soakage pits for PF toilets, and sullage water disposal to storm drains have been used successfully. If the toilets are of the cistern-flush type, a septic tank should be provided so that the sewers can be of small diameter and laid at flat gradients. The septic tank should follow the design described for sewered PF toilets in chapter 12. If the toilets are aquaprivies, the equivalent of a septic tank is already included, and provision needs to be made for only a tank to settle sullage. If the terrain is such that velocities of 1 meter per second can be obtained in the sewer without the need for excessive excavation or pumping, the sewerage system can be of the conventional kind, and the septic tank would no longer be necessary. In areas where communal sanitation blocks can be installed near a trunk sewer serving other parts of the town, they should of course be connected to it.

Design Criteria

There are basically two approaches to the design of communal sanitation blocks. The first is to have a truly public system in which a user can enter any toilet compartment not in use at the time. The second approach is to provide within the communal block cubicles for the exclusive use of one household. This second system, essentially a compromise between public and private facilities, has been tried with considerable success in some parts of India; experience has shown that each household will zealously guard

its own cubicle and keep it clean, but that maintenance of the communal parts (for example, the passageways and particularly the effluent disposal system) can cause organizational problems. This system is undoubtedly superior to the truly public system, but it is also more expensive, since a greater number (depending on the average household size) of toilet compartments is needed. The advantage to the municipality is that it is relatively easy to levy rental fees and collect payment from each household using the facility.

A third approach to the design of communal facilities is to provide a sanitation block of the first type but reserved for the exclusive use of a large kinship group. This has been successful in the densely populated old city of Ibadan, Nigeria. Individual households that belong to a patrilineal kinship group or extended family of between 100 and 1,000 members are located on the same piece of land, which is held in communal ownership by the kinship group. Each kinship group is (or is planned to be) provided with a "comfort station," essentially a communal sanitation block with toilets, showers, and laundry facilities. Part of the construction cost is borne by the extended family and part by the government; the family is responsible for maintenance and also for paying the water and electricity charges. Clearly, this approach to the provision of communal sanitation facilities can only work under suitable social conditions. The success of the Ibadan comfort stations probably owes more to their social setting than to their technical design.

Number of toilet compartments required

In the truly public communal sanitation block, the best available evidence suggests that one toilet compartment can serve twenty-five to fifty people. Although it seems prudent to take a design figure of

Figure 19-1. Schematic of a Communal Sanitation Facility

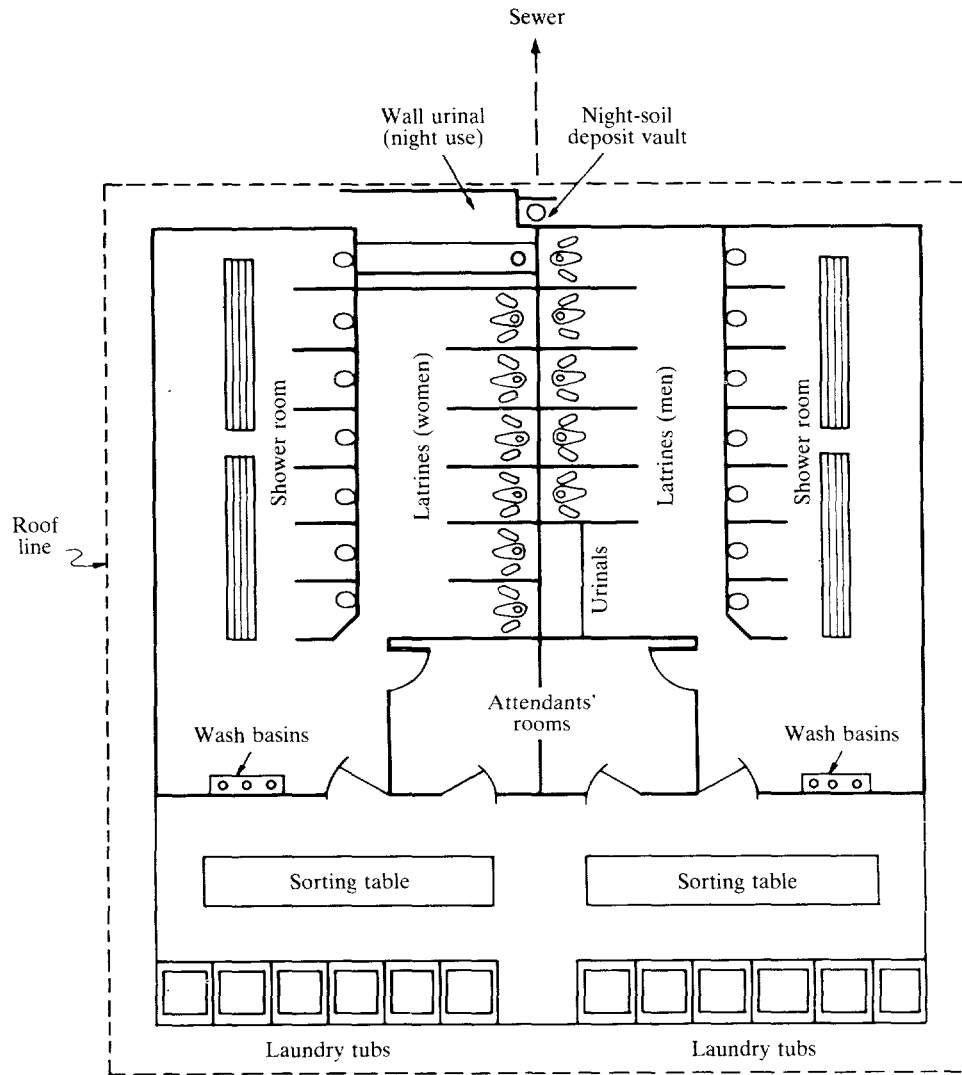

twenty-five users per compartment, it must be stressed that there are hardly any good field data available to support such a figure. For example, the OXFAM disaster sanitation unit in the “bustee” areas of urban Bangladesh, which is designed for a population of 500 and is provided with twenty squatting plates, is able to serve a population of 1,000 to 1,500 (that is, fifty to seventy-five users per squatting plate or two to three times the design figure). How well it serves that number of people—in the sense of the time spent in queuing, especially at “peak” periods—has not been reported.

The toilet compartments should be arranged in separate blocks for men and women. Urinals should be provided in the men’s block, and the total number

of urinals and compartments in the men’s block should be the same as the number of compartments in the women’s.

Location

In high-density areas (over 1,000 persons per hectare), the number of people that can be served by one communal sanitation block (usually 200 to 500), rather than the distance people can be expected to walk to the block will usually determine the required number and location of communal facilities. For example, if the population density is such that only one communal block is required per hectare, then the maximum distance that people would be required to

walk is around 100 meters, which is a 1.2-minute walk at a speed of 5 kilometers per hour.

Toilet type

The ideal toilet for installation in a communal sanitation facility is a PF or low-volume cistern-flush toilet. Water use may amount to 15 to 20 liters per capita daily. Other toilets have been used: for example, aquaprivies in the Ibadan comfort stations, where communal facilities serving individual household compartments or large kinship groups have been successful.

Shower and laundry facilities

If shower and clothes-washing facilities are not available in individual households, these should be provided at the communal sanitation blocks; the water requirement for showering is 15 to 25 liters per capita daily. Additionally, hand basins should be provided at the rate of one for ten people; water use may be estimated as 5 to 15 liters per capita daily. Water use for both showers and hand basins may be considerably reduced by the provision of water-saving plumbing fixtures. In warm climates it is usually not necessary to provide hot water, since the water storage tank will normally contain water warm enough for personal washing.

It may also be necessary to provide laundry facilities. The exact style of these facilities should conform to local preference. Approximately one washing tub should be provided for fifty people. Clotheslines may be required.

In communal facilities with compartments reserved for the exclusive use of one household, each compartment may contain a shower and hand basin in addition to the toilet. Whether it is necessary to provide a private laundry tub as well, rather than communal laundry facilities, is a decision best made after discussion with the community.

Advantages and disadvantages

The principal advantage of communal facilities is their low cost. Because they serve many people, they are substantially cheaper on a per capita basis than individual household facilities. They have many disadvantages, however, and the decision to install communal facilities is one that should never be taken lightly. The basic problem is that the facility appears to belong to no one, so that there is very little com-

mitment by individual users to keep it clean and operating properly. Once a toilet compartment is fouled, the next user may have no choice but to foul it further. As a result, many communal toilet blocks are in a very unhygienic state. To avoid this it is essential to provide one or more well-paid attendants to keep the facilities in good operational order; lighting and a water supply must also be provided. It is also essential that the employers of the attendants (often the municipality) should regularly inspect the facilities to make sure that they are being properly maintained.

There are four technical disadvantages of communal sanitation facilities. First, there is the difficult question of privacy. A community's requirements for privacy must be clearly understood and respected. Cultural attitudes toward defecation vary, but generally it is regarded as a private, personal act. Thus, at the least, each toilet within the communal block should be designed as a separate compartment and provided with a door that can be bolted; this may appear obvious, but there are many public toilet blocks that merely contain a row of holes with no internal partitioning whatsoever. In some societies, however, privacy is not so highly regarded. It is clear that questions of privacy must be discussed with the community by the program's behavioral scientist (see chapter 3). Second, there is the problem of defecation at night and during illness and wet or cold weather. If the communal block is not lit, it may not be used at night. In any case it is surely unreasonable to expect even fit adults—let alone the young, the old, or the infirm—to walk 100 meters or more in the middle of the night or in torrential rain, often along a dark or muddy street or alleyway. There must be some general provision (including guidance to the community) for the disposal of what accumulates during the night or inclement weather.

If it is accepted that the provision of individual household facilities (of whatever type) is the ultimate objective of sanitation program planning, then the third disadvantage of communal facilities is that they cannot be upgraded. This means that they should be designed with eventual replacement by individual household facilities in mind. In this connection it is sensible to tie the provision of sanitation facilities to residential upgrading programs; this is especially advisable in the case of slum improvement schemes.

The fourth disadvantage of communal facilities is their space requirement. Depending upon the type of excreta disposal and the service level provided, this space may vary from 5 to 10 percent of the total area occupied by the community.

20

Disposal and Treatment of Sullage

THE ADOPTION of on-site excreta disposal technologies such as improved pit latrines, composting toilets, and PF latrines with soakage pits or vaults (but excluding septic tanks) requires that separate provision be made for sullage disposal. Sullage is defined here as all domestic wastewater other than toilet wastes: the wastewater from showers and sinks, including laundry and kitchen wastes as well as water used for personal washing. It contains some excreted pathogens; per capita contributions of enteric indicator bacteria in sullage are generally 10^4 to 10^5 lower than those in sewage. Sullage also contains a variety of organic compounds, most of which are readily biodegradable (with the notable exception of “hard” detergents if these are present in locally manufactured washing powders). Approximately half of the total household production of waste organics (excluding garbage) is associated with sullage—that is, with some 20 to 30 grams of biochemical oxygen demand (BOD) per capita daily. This figure, however, depends on water consumption; a family with suitable facilities and abundant water for personal dish and clothes washing will obviously generate more sullage BOD than one that obtains only small quantities of water for drinking and cooking purposes from a public standpipe and uses stream water for washing clothes or sand to clean cooking utensils.

Sullage Volume and BOD

The volume of sullage generated is clearly related to water consumption. In many industrialized countries sullage accounts for 50 to 70 percent of total domestic water use, the balance being used to flush cistern-flush toilets. A similar situation exists in the more affluent communities of developing countries. In communities that have a water consumption of 200 to 300 liters per capita daily and cistern-flush toilets, the volume of sullage generated is approxi-

mately 60 percent of the water consumption (excluding garden watering). In other (less affluent) urban communities in developing countries, the prediction of sullage volumes is more difficult. Tentative estimates, however, are:

- In households with a hand-carried water supply (obtained from public standpipes or vendors) and pit latrines or composting toilets, sullage generation may be conservatively estimated as the water consumption; that is, normally around 20 to 30 liters per capita daily less any amount used for PF toilets.
- In households with an on-site, single-tap water supply and PF toilets or vaults, the sullage volume can be taken as the water consumption (excluding that used for garden watering and the 3 to 6 liters per capita daily of flushwater); that is, normally about 50 to 100 liters per capita daily.

Local figures of water use should of course be used wherever possible. They are seldom difficult to obtain, even by actual measurement in the field. In contrast, it is very time consuming to obtain good estimates of the daily per capita BOD contribution in sullage. Reliable data on this are not available for urban areas in developing countries, but it is probably reasonable to estimate that the BOD_5 of sullage is of the order of 100 to 350 milligrams per liter.

In developing countries sullage may have a wastewater with as much BOD_5 as raw sewage in North America. Indeed, there are many canals and streams in urban areas of developing countries that are grossly polluted (BOD_5 of up to 250 milligrams per liter) by sullage and garbage. Indiscriminate sullage disposal may not only damage the environment but also may have serious public health consequences.

There are four basic kinds of sullage disposal systems:

- Disposal by tipping of containers in the street, house yard, or garden
- On-site disposal in soakaways
- Disposal in open drains (commonly stormwater drains)
- Disposal in covered drains or sewers.

Each system has different health risks, and these are reviewed before design considerations are discussed.

Health Aspects

Tipping sullage on the ground in backyards or gardens may create breeding sites for either anopheline or culicine mosquitoes, including *Culex pipiens*, which is a cosmopolitan nuisance, a potential vector of bancroftian filariasis in some areas of the world, and a species reported to prefer polluted water. Tipping may also create muddy and unsanitary conditions that could help to promote the development of helminth ova, which require a fairly moist environment. In a clean dry yard, ova from children's feces are unlikely to develop. A wet muddy yard, however, will conceal any feces deposited and will promote development of worm eggs and larvae. There is evidence that families whose yards are clean and dry (because of hygienic practices, soil type, or both) have lower intensities of *Ascaris* infection than do other families. Sullage containing pathogens from bathwater may infect children playing in the yard. In permeable soils or where evaporation is high, and where sullage production and housing density are low, tipping of sullage onto the ground is unlikely to give rise to a significant health hazard. Where the soil is less permeable, evaporation is low, and land slopes permit ponding, a separate system for sullage disposal becomes necessary. Similarly, where either water use or housing density is high, an alternative method of sullage disposal becomes essential.

Sullage disposal in properly designed and constructed ground seepage pits causes only a low risk of groundwater contamination. The risk of microbiological and nitrate pollution of groundwater from sullage is very much lower than it is from sewage, since sullage contains far fewer pathogens. It also contains much less nitrogen, which can pose a separate problem in areas where infant formulas are used.

Sullage disposal in open drains, such as stormwater drains, provides the most readily identifiable potential health risk—namely, promotion of mosquito breeding. In areas of year-round rainfall, these drains will contain water continuously; if they are kept free

of garbage and are well designed, they will flow freely and provide few sites for mosquitoes to breed. The presence or absence of sullage will therefore make no difference. In areas of seasonal rainfall, however, especially where the drains may become blocked with garbage or trash during months of low rainfall, the addition of sullage will create year-round water and thus year-round mosquito breeding where previously only seasonal breeding may have occurred. Here it is not the quality of the sullage that is important, since ponded stormwater would also be sufficiently polluted to allow *Culex pipiens* to breed, but it is rather the continuous production of sullage that may have the effect of converting wet season breeding into year-round breeding in areas where the stormwater drains may pond. The change from wet-season breeding to year-round breeding may lead to an increase in the transmission, prevalence, and intensity of filariasis, although there are no field data to confirm this hypothesis.

Sullage disposal in closed drains or sewers is expensive but causes no special health problems unless sullage is eventually discharged without treatment into a sluggish or intermittent stream where it may promote *Culex* breeding. The disposal of sullage, along with excreta, into sanitary sewers also presents no additional health risks, but this in itself is no justification for the provision of conventional sanitary sewers.

Design Criteria

This section outlines design features for seepage pits, storm drains, and sullage treatment facilities.

Seepage pits

A suitable design for a seepage pit for use in permeable soils is shown in figure 14-3. The pit may be circular, square, rectangular, or even irregular in plan to suit the space available. The side walls may be lined with open brickwork or unlined and filled with rock (50- to 100-millimeter grading) or broken bricks. The rate of infiltration of sullage is approximately three times higher than that of conventional septic tank effluent; that is, up to 90 liters per square meter of sidewall area daily. For the purposes of design, a rate of 30 liters per square meter should be used, unless a higher rate is known to be more appropriate.

Stormwater drains

If stormwater drains are used for sullage disposal, they must be designed so that they can handle low sullage flows, as well as flood peaks, without nuisance. Storm drains are normally designed with an approximately trapezoidal cross-section with a fairly wide base. This means that the depth and velocity of flow of the relatively small amounts of sullage (relative, that is, to the drain's stormwater capacity) will be low, and the risk of blockage and ponding high. If the storm drains are already in existence and lined, it is advisable (but somewhat costly) to modify the channel section by placing a small trapezoidal or semicircular channel along the invert where the sullage can flow with a higher velocity in the central section only. If the drains are not already lined, it would be advisable to pave the invert to provide a similar channel. If surface drainage is to be provided at the same time as the improvements in excreta and sullage disposal, it may be advisable to consider alternative channel sections (see figure 20-1).

Whatever channel section is adopted, it is necessary to maintain the drains routinely. This includes removal of blockages and perhaps flushing with surface water. The maintenance can be done by municipal workers, by contractors from the private sector, or by community effort motivated and organized on a neighborhood basis. The material removed from the drains should be disposed of in a landfill.

Sullage treatment

As noted above, sullage may have a high BOD, and large volumes of sullage may require treatment prior to discharge into local streams or rivers, unless the reticulation or the flow of these watercourses is such that the sullage would cause little additional pollution.¹ If stormwater drains are used for sullage collection, these should discharge into a single facultative waste stabilization pond, which is normally the most convenient method of treatment wherever land is available. Maturation ponds are not necessary because the concentration of excreted pathogens in sullage is small. The pond should be protected from high stormwater flows in the wet season by incor-

Figure 20-1. *Improved Stormwater Channels for Drainage of Sullage*

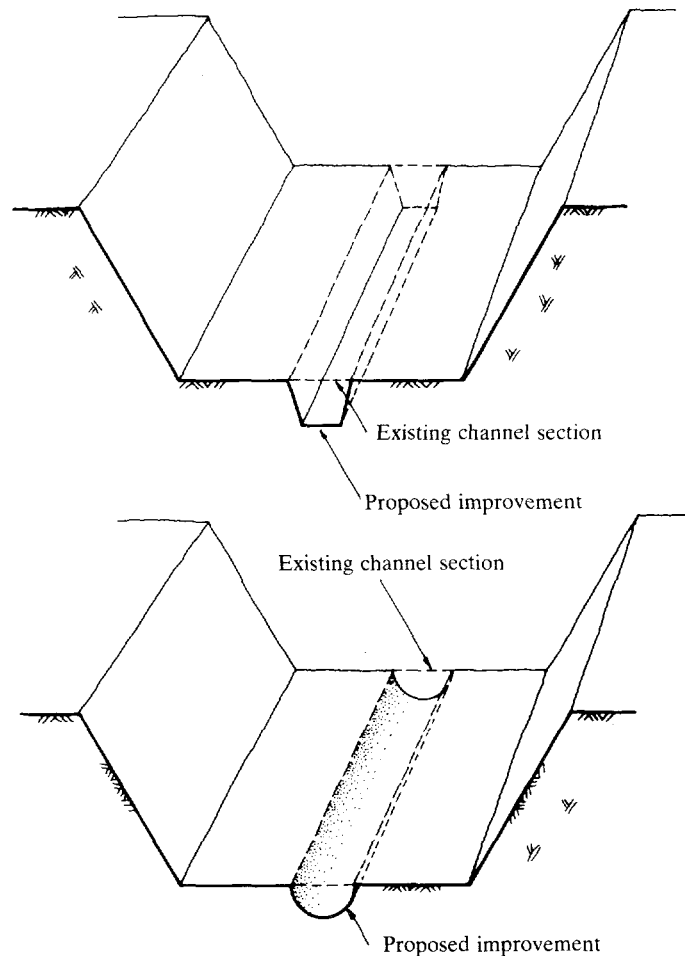

porating a simple stormwater overflow weir at the pond inlet structure. For a detailed discussion of pond design criteria, see chapter 21.

Note to Chapter 20

1. See Kalbermatten, Julius, and Gunnerson (1982), chapter 2 for a comparison of a conventional sewerage system with a vault and vacuum truck system with sullage disposal to surface drains and channels.

21

Off-site Treatment

THE DEGREE to which excreta and sewage are treated is largely influenced by what is to be done with the resulting solid and liquid products. Minimal treatment is required for small flows discharged to the sea; maximal treatment is needed for effluents used for irrigation of food crops.

In general the treatment of human wastes in developing countries has two principal objectives: the removal or destruction of excreted pathogens and the oxidation of organic matter. The first objective is required to protect public health and the second to prevent pollution in the watercourse receiving the effluent. In communities where the incidence and prevalence of excreta-related infections are high and where the density of excreted pathogens in human wastes is therefore also high, the first objective is the more important. It is usually achieved by providing a suitable combination of time and temperature in the treatment works (see figure 15-1). It is fortuitous that the commonly selected combinations of time and temperature for pathogen removal enable simultaneous achievement of the second objective.

In this chapter emphasis is placed on the effectiveness of simple, low-cost processes in achieving low rates of pathogen survival. A brief discussion of conventional sewage treatment processes, which are not only more expensive but, without disinfection of the effluent, not very effective in pathogen removal, is given in chapter 15. Design examples of treatment processes discussed below are shown in the appendix to this chapter. Layout and design details are shown in figures 21-1 through 21-4.

Waste Stabilization Ponds

Waste stabilization ponds are large, shallow ponds in which organic wastes are decomposed by microorganisms in a combination of natural processes involving both bacteria and algae. Stabilization pond

systems can treat raw sewage, the effluent from sewerer PF toilets, diluted night soil, or sullage.

Waste stabilization ponds are the most economical method of sewage treatment wherever land is available at relatively low cost. Their principal advantages in developing countries are that they remove excreted pathogens at a much lower cost than any other form of treatment and that they have minimum operating and maintenance requirements. In fact, a pond system *can* achieve the total removal from the effluent of all excreted pathogens. This is not normally done because the possible additional benefits resulting from achieving zero survival, rather than very low survival, commonly are less than the associated incremental costs.

There are three types of ponds in common use:

- Anaerobic pretreatment ponds, which function much as open septic tanks. They have retention times of one to five days and depths of 2 to 4 meters. Anaerobic ponds require periodic desludging and, if not properly designed and operated, will have strong odors.
- Facultative ponds, in which the oxygen necessary for biooxidation of the organic material is supplied principally by photosynthetic algae that grow in them naturally and with great profusion. They have retention times of five to thirty days (sometimes more) and depths of 1 to 1.5 meters. The lower layers of these ponds are usually anaerobic.
- Aerobic maturation ponds, which receive facultative pond effluent and are responsible for the quality of the final effluent. They have retention times of five to ten days and depths of about 1 to 1.5 meters. Each pond in a series of ponds will generally reduce the fecal coliform concentration by about an order of magnitude.

Anaerobic and facultative ponds are designed for BOD removal, whereas the function of maturation

Figure 21-1. *Stabilization Pond Layout and Details*
(millimeters)

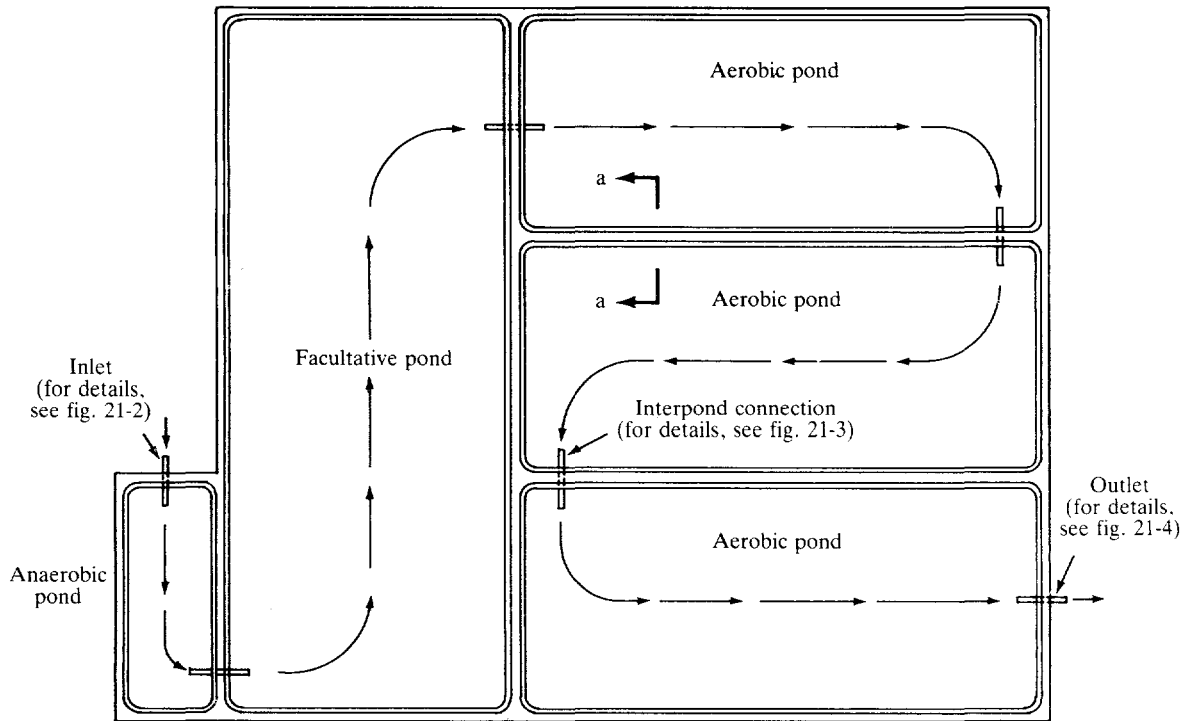

Plan layout
(not to scale)

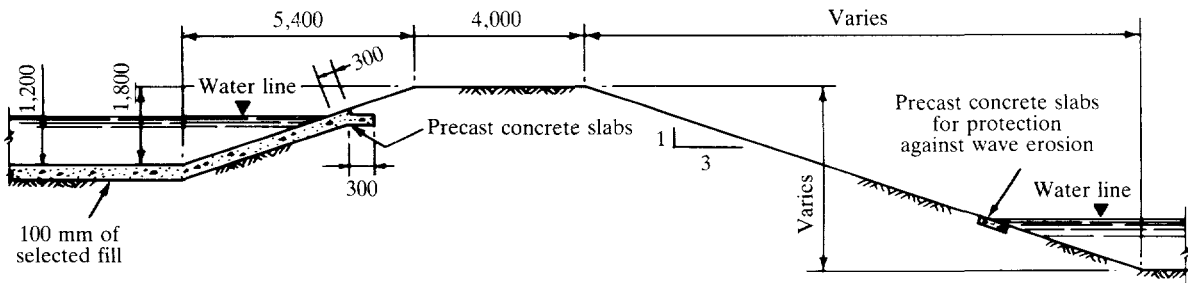

Section a-a

Detail of a typical embankment

Figure 21-2. *Inlet Structures for Stabilization Ponds*
(millimeters)

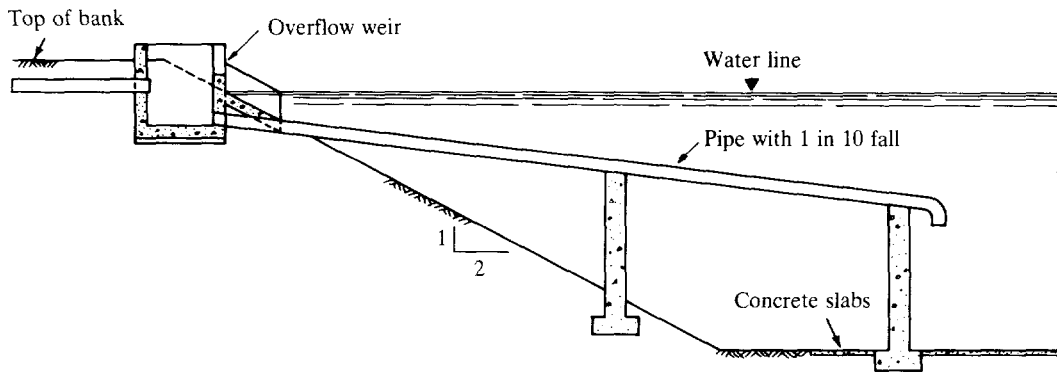

Inlet arrangement for a deep anaerobic lagoon
(the pipe should discharge well away from the embankment to avoid the development of sludge banks)

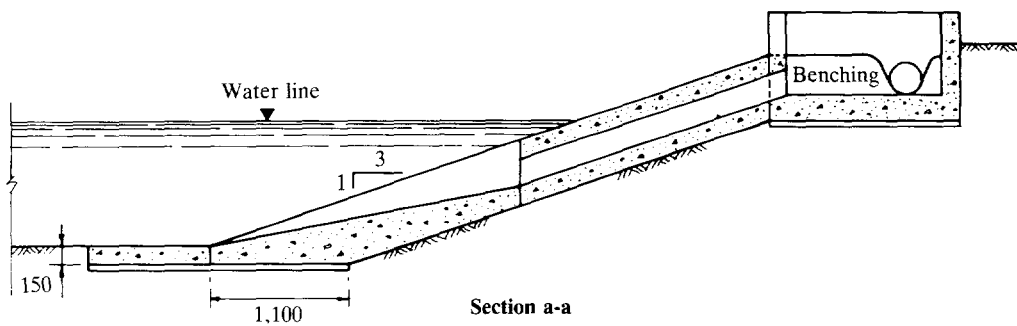
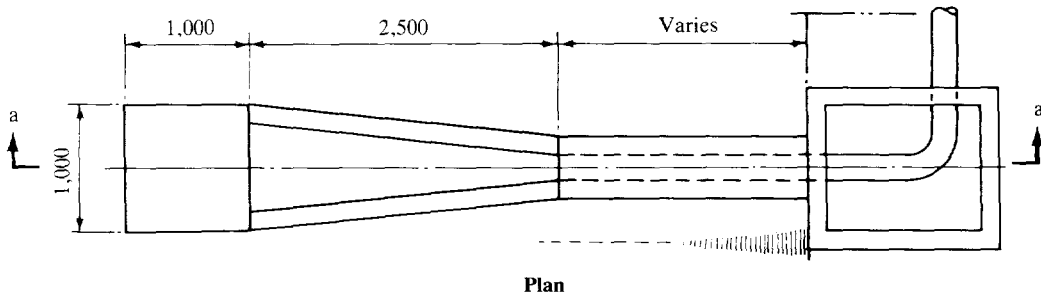
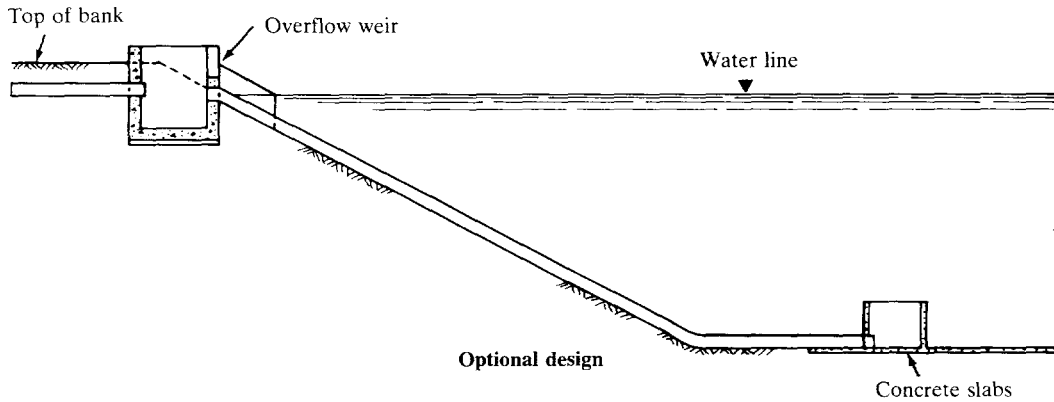

Inlet chute for a facultative or maturation lagoon

Source: Mara (1976). © John Wiley and Sons Ltd.; used by permission.

Figure 21-3. *Alternative Interpond Connections*
(millimeters)

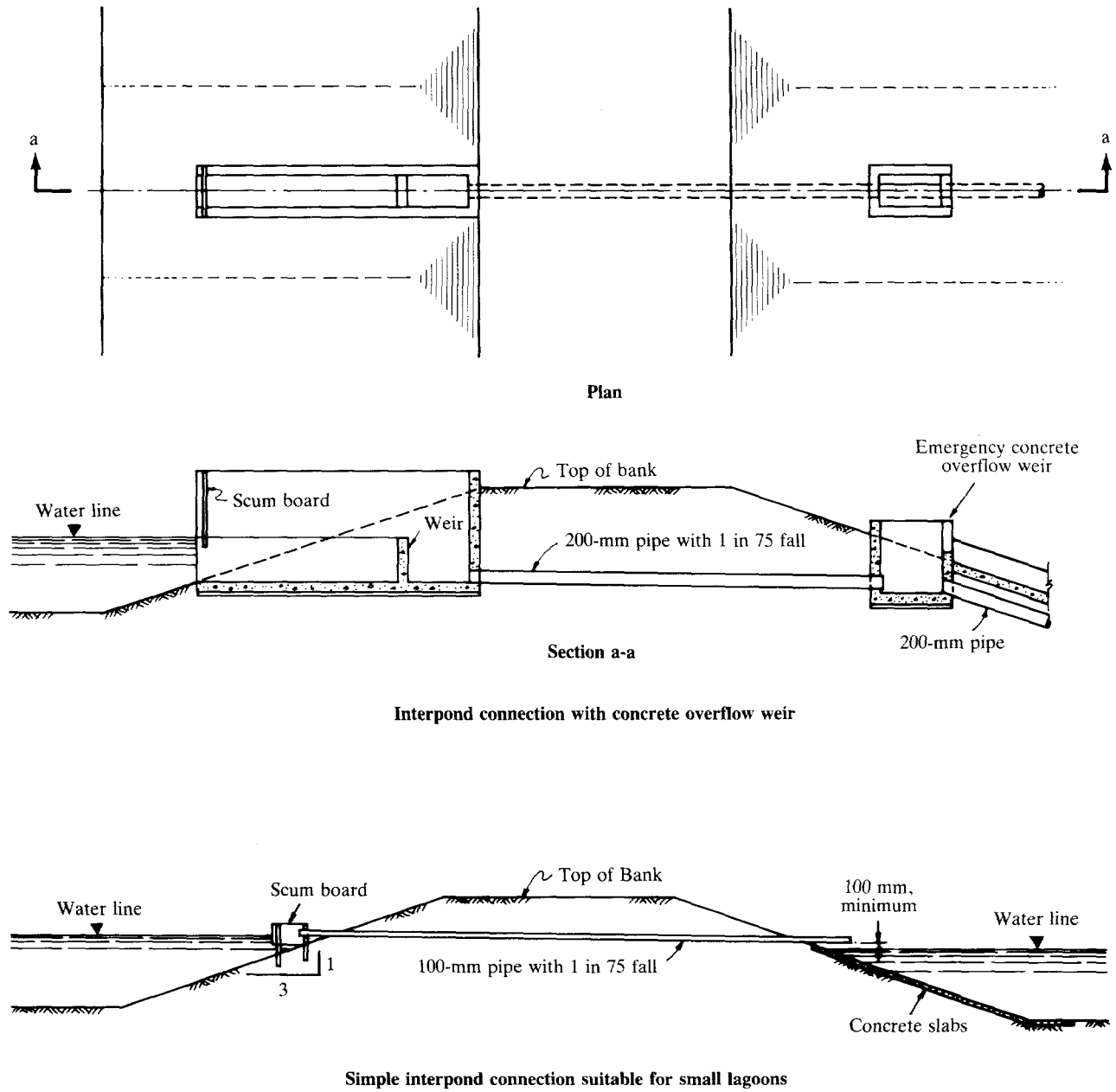

Note: Interpond connection, comprising a concrete overflow weir and a downstream junction chamber, would be connected to an inlet chute similar to that shown in figure 21-2.
Source: Mara (1976). ©John Wiley and Sons Ltd.; used by permission.

Figure 21-4. Outlet Structures for Stabilization Ponds
(millimeters)

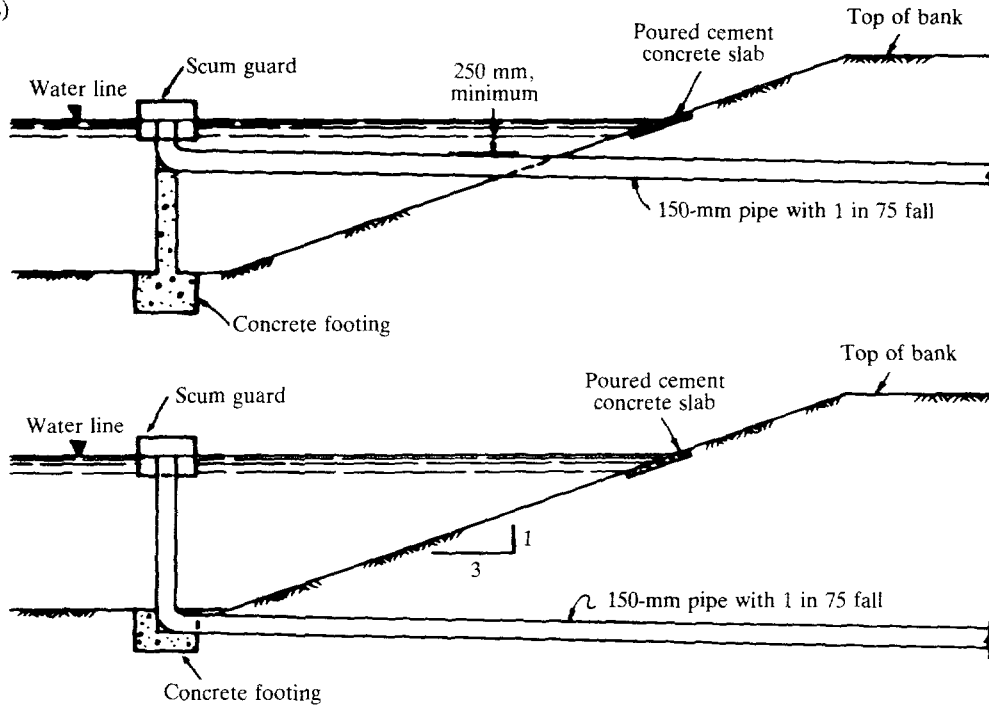

Alternative interpond connections made from standard pipe fittings

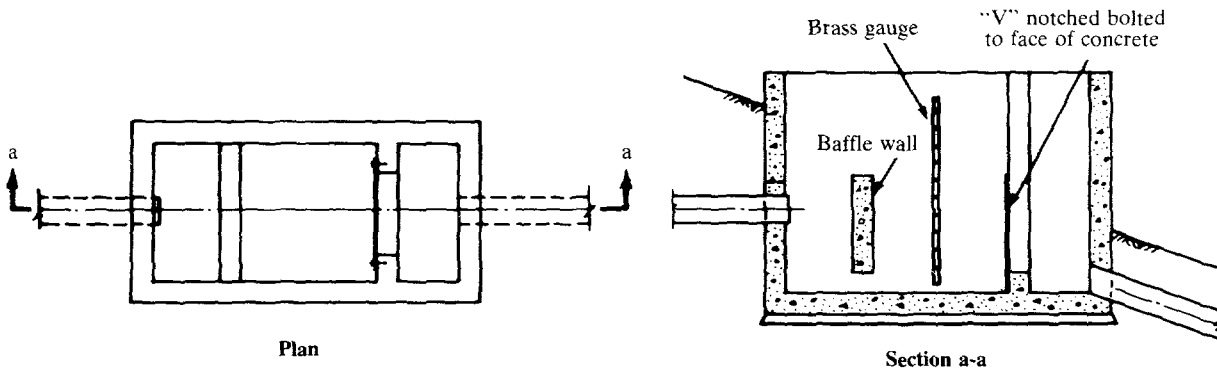

Flow-measuring chamber for final effluent

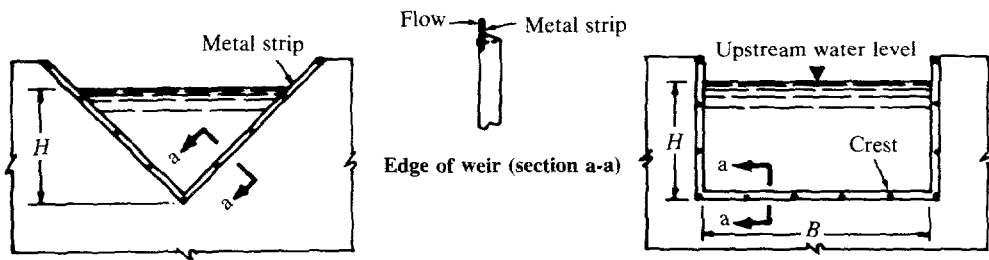

90° triangular weir ($Q, \text{m}^3/\text{sec} = 1.38H^{5/2}$)

Rectangular weir ($Q, \text{m}^3/\text{sec} = 1.84BH^{3/2}$)

Note: Q , quantity; m^3/sec , cubic meters per second; H , heights; B , breadth.

Sources: For flow-measuring chamber, Mara (1976; ©John Wiley and sons Ltd.; used by permission). For weirs, Okun and Ponghis (1975).

ponds is the destruction or removal of excreted pathogens. Thus, these three types of ponds should normally be used in conjunction to form a *series* of ponds. A single facultative pond treating domestic wastes is unsatisfactory; good designs incorporate a facultative pond and two or more maturation ponds. For strong wastes ($BOD_5 > 400$ milligrams per liter), the use of anaerobic ponds as pretreatment units ahead of facultative ponds is often advantageous since the anaerobic ponds minimize the land requirements of the whole pond system.

Well-designed pond systems, incorporating a minimum of three ponds in series and having a minimum overall retention time of twenty days, produce an effluent that will either be completely pathogen free or will contain only small numbers of enteric bacteria and viruses. Pathogenic helminths and protozoa will be completely eliminated. Any bacterial or viral pollution can be reduced or eliminated by adding more ponds to the system. The effluent is suitable for direct reuse or discharge into receiving waters.

Snail and mosquito breeding in properly maintained waste stabilization ponds does not occur. It is associated only with poor maintenance, which allows vegetation to emerge from the pond bottom or to grow down the embankment into the pond, thereby providing shaded breeding sites. This can be prevented by providing pond depths of at least 1 meter and concrete slabs or stone riprap at top water level. The latter strategy also prevents erosion of the embankment by wave action.

Proper and regular maintenance of ponds is simple but nonetheless essential. It consists merely of cutting the grass on the embankments and removing floating scum mats from the pond surfaces.

Night-Soil Treatment Ponds

There is little experience with pond systems that treat night soil, but there is no basis for suggesting that the design and operation of night-soil ponds is different from that of ponds treating strong agricultural wastes or, indeed, domestic sewage. Since night-soil ponds are not discussed in standard sanitary engineering texts, a typical design example is presented in the appendix to this chapter. The design criteria adopted are conservative, and it is anticipated that, as more field data on night-soil ponds become available, the criteria may be considerably refined.

Night soil is taken here to mean the material removed from vault toilets. This may be more dilute

than the contents of bucket latrines. In areas where PF latrines are used, the vaults will contain 3 to 6 liters per capita daily of PF water. Assume that the average adult daily produces 250 grams (wet weight) of excreta, with a moisture content of 80 percent, and 1.2 liter of urine, with a total BOD_5 of 21 grams. The vault contents will thus have a solid concentration of 0.7 to 1.1 percent and BOD_5 of 2,800 to 4,800 milligrams per liter, depending on the amount of PF water. If additional water is used for anal cleansing, these figures will decrease slightly, and if paper is used they will be higher. Thus night soil from vault toilets is a dilute slurry with a reasonably high BOD . It is often thought to be similar to primary sewage sludge, except that it has a higher pH (usually >8), and about 60 percent of its solids are present in true solution.

Thermophilic Composting

Another suitable treatment method is thermophilic composting. Before vault night soil, septic tank sludge, or raw or digested sludge can be composted, however, its moisture content must be reduced to between 40 and 60 percent. Mechanical dewatering, although simple enough in theory, is not considered appropriate because it is in practice a complex process with many snags. Experience with conventional sludge dewatering in Europe and North America, especially at smaller works, has not been encouraging, and there is no reason to suppose that night-soil dewatering is likely to be more successful in developing countries. Mechanical dewatering of any type requires a reliable and continuous supply of chemicals and energy. In addition, the liquor removed from the dewatered sludge contains high concentrations of both BOD and excreted pathogens and requires treatment in aerobic waste stabilization ponds.

In contrast, moisture control of vault night soil is more simply achieved, and at lower cost, by mixing it with moisture-absorbing, biodegradable waste materials such as sawdust, wood chips, rice husks, cotton gin trash, straw, leaves, or previously composted night soil. Sufficient materials should be added to reduce the moisture to below 60 percent; the precise quantities required must be determined by experiment. The same materials will raise the carbon-nitrogen ratio in the night soil from about 10 to 1 to the 20 or 30 to 1 needed for preventing loss of ammonia and for optimum composting. Note that previously composted material can be recycled and used as the moisture-absorbing material.

Figure 21-5. Beltsville Agricultural Research Center (BARC) System for High-rate Thermophilic Composting (millimeters)

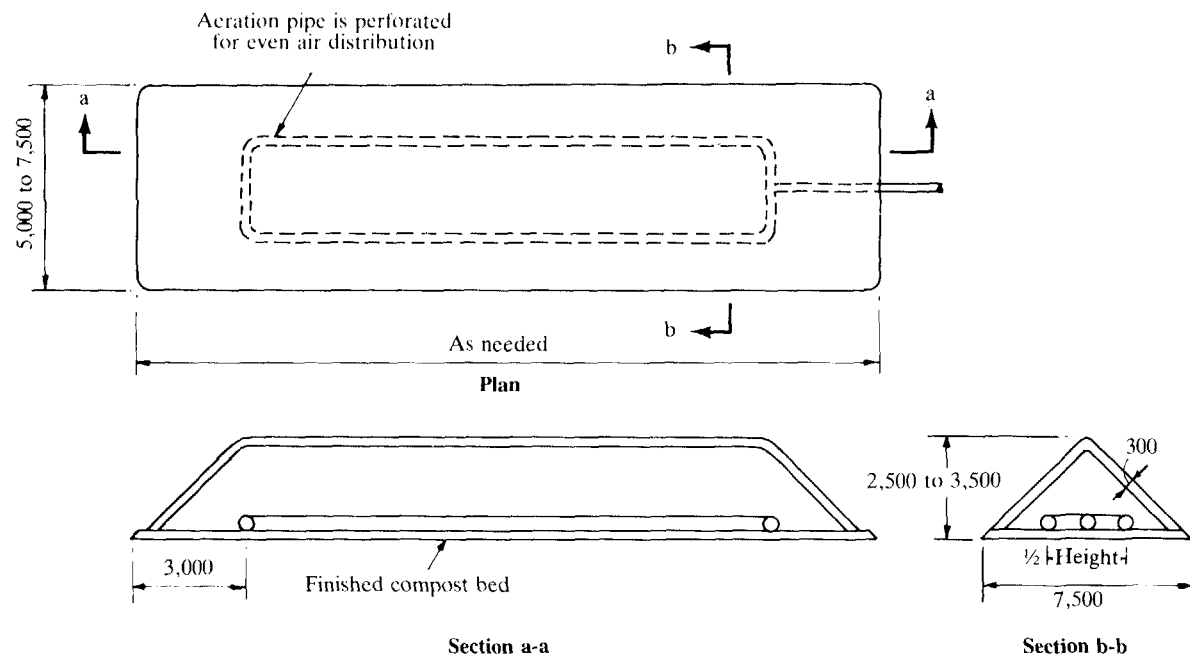

Note: BARC (Beltsville, Maryland) is a facility of the U. S. Department of Agriculture.

Night soil with moisture levels below 60 percent may be composted in windrows in the open air for a period of two to three months. Windrows are long mounds of the composting material, usually approximately a trapezoidal cross-section. Typical dimensions are: base width, 1.5 to 2.0 meters; top width, 0.75 to 1.0 meter; height, 1.5 to 2.5 meters. Aerobic conditions within the windrow may be maintained by turning over the windrow contents daily at first, decreasing to three- to five-day intervals by the end of a three- to five-week composting period; this essentially entails building a second windrow from the contents of the first. This procedure also ensures that all the material is exposed to the high temperatures of 55°C or more generated within the windrow by thermophilic bacterial activity.

High-rate composting can be achieved in the windrow by forced draft ventilation with air blowers. Alternative applications of this process, known as the BARC¹ aerated pile composting system, are shown diagrammatically in figure 21-5; further details of the process are given in the appendix to this chapter. The process essentially consists of the maintenance of highly aerobic conditions in the windrow by drawing air in through the windrow surface and exhausting it from the bottom through a series of perforated pipes and a 1/3-horsepower blower. Very high temperatures (>80°C) have been achieved using this process, even during wet weather and when the ambient temperature was below 0°C. Pathogen destruction is complete within a few days, but the process is continued for up to thirty days to produce a more stable compost. Odors are eliminated by passing the exhaust air through a filtering pile of finished compost. The BARC process is inexpensive: estimated total annual per capita costs, based on U.S. experience, are \$0.64 to \$0.85 (1977 prices for a plant treating 10 tons of dry night-soil solids per day). These costs can be reduced further if the compost is marketed. If there is no local use for the compost, the process should be stopped after ten days and the pathogen-free product disposed of on land.

There are many other technologies for aerobic composting of various combinations of night soil, sewage sludge, livestock manures, and refuse with high organic contents. Among these is the Dutch VAM system, in which unsorted municipal refuse is mechanically placed in large windrows into which air may be forced from pipes lying underneath the pile (the opposite of the BARC system). Other systems include: rotating inclined cylinders, which tumble and aerate solid wastes for six to eight days; closed bins or towers, built where space is restricted and in

which air is forced through the composting wastes, as in the Dano BIOREACTOR system; and closed systems that can recycle a portion of the product for bulking and moisture control.

Some proprietary composting systems include "seeding" with expensive special cultures of microorganisms; these have been marketed from time to time for many years on the basis of promotional promises. They do neither harm nor good; the bacteria and other microflora needed for composting are already present in raw wastes in more than sufficient number to provide the seeding.

Information on composting presented in this chapter has been limited to the BARC process because this system is simpler, less expensive, and less complicated than other aerobic systems and because it works. The alternative system, designed for limited space and based on similar principles, is the BIOREACTOR. The most complete single source of information on the science and technology of composting is published serially by Kumpf, Maas, and Straub (1964-80). A current summary in which health aspects are stressed can be found in Shuval, Gunnerson, and Julius (1980). A detailed description of the BARC system and its operation is contained in the appendix to this chapter.

Appendix. Examples of Waste Treatment Calculations

Waste stabilization ponds

ANAEROBIC PONDS. The kinetics of BOD removal in anaerobic ponds is similar to that in conventional anaerobic digesters. In practice, lack of reliable field data has led to inherently conservative empirical designs based on the daily quantity of BOD₅ applied per unit volume:²

$$(21.1) \quad \lambda_v = \frac{L_i Q}{V},$$

where λ_v = volumetric BOD₅ loading in g/m³/d
 L_i = influent BOD₅ concentration in mg/l
 Q = influent flow rate in m³/d
 V = volume of pond in m³.

Provided that the volumetric BOD₅ loading is below 400 g/m³/d and stable alkaline fermentation with methane evolution is established, minimal odor release occurs. If the wastewater is acidic, the pH should be adjusted with lime soda ash to a pH between 7 and 8.

Anaerobic ponds should be desludged when they become half full of sludge. A sludge accumulation rate of 0.04 m³ per person yearly is generally observed at temperatures above 15°C.

FACULTATIVE PONDS. There are a number of design procedures for facultative ponds, which generally have a depth of between 1 and 2 m. The one described here is based on the areal BOD₅ loading, λ_s ; this parameter is the daily quantity of BOD₅ applied to the pond per unit surface area:

$$(21.2) \quad \lambda_s = 10L_i \frac{Q}{A},$$

where λ_s = areal BOD₅ loading in kg/ha/d, A = pond area in m², and L_i and Q are as defined above.

The maximum value of λ_s that can be used for design is a function of temperature from an analysis of performance data of facultative ponds obtained worldwide. It is recommended that design be based on the relationship:

$$(21.3) \quad \lambda_s = 20T - 120,$$

where T = mean temperature of the coldest month, in degrees Celsius. (This formula works well in areas having a temperature range of 15°C and up.) Thus, the pond area is given by:

$$(21.4) \quad A = \frac{L_i Q}{2(T - 6)}.$$

BOD₅ removal in facultative ponds is a function of the loading. McGarry and Pescod (1970) found the following relationship in equation (21.5), where λ_r is the BOD₅ removed in kg/ha/d:

$$(21.5) \quad \lambda_r = 0.725\lambda_s + 10.75.$$

Percentage BOD₅ removal is generally from 70 to 85 percent. An effluent BOD₅ over 100 mg/l indicates a predominantly anaerobic pond; 40 to 80 mg/l indicates a predominantly aerobic one. Additional removals are achieved in maturation ponds.

In facultative ponds that treat raw or screened sewage, a sludge layer forms on the pond bottom. Facultative ponds should be desludged when they are a quarter full of sludge; as with anaerobic ponds, a sludge accumulation rate of 0.04 m³ per person yearly may be predicted (assuming that suitable traps are provided to remove grit, sand, or ash residues that may be in the incoming sewage). Facultative ponds that receive the effluent from anaerobic ponds (or sewered PF toilets) do not normally require desludging.

MATURATION PONDS. Maturation ponds are usually designed on the basis of fecal coliform removal rather than BOD removal. The model most commonly used in design for the removal of fecal coliforms in waste stabilization ponds is first-order kinetics in a completely mixed reactor. The kinetic equation is:

$$(21.6) \quad N_e = \frac{N_i}{(1 + K_{b(T)} t^*)^{1/n}}$$

where N_e = number of fecal coliforms per 100 ml of effluent

N_i = number of fecal coliforms per 100 ml of influent

$K_{b(T)}$ = first-order rate constant for fecal coliform removal at T °C, day⁻¹,

t^* = mean hydraulic retention time in days.

The rate constant varies with temperature according to the equation:

$$(21.7) \quad K_{b(T)} = 2.6 (1.19)^{T-20}.$$

In a series of anaerobic, facultative, and maturation ponds, equation (21.6) is written as:

$$(21.8) \quad N_e = \frac{N_i}{(1 + K_{b(T)} t_{an}^*) (1 + K_{b(T)} t_{fac}^*) (1 + K_{b(T)} t_{mat}^*)^n}$$

where t_{an}^* , t_{fac}^* , and t_{mat}^* are the retention times in the anaerobic, facultative, and maturation ponds, respectively, and n is the number of maturation ponds (which have the same retention time and which ideally are all the same size); N_i and N_e refer to the fecal coliform concentrations in the raw sewage and the final effluent, respectively.

Retention times in maturation ponds are usually in the range of five to ten days, and the number of maturation ponds required depends on the desired values of N_e . A representative design value of N_e is 1×10^8 per 100 ml. Note the two maturation ponds, each with five to ten days' retention, will normally reduce the BOD₅ of facultative pond effluent from about 60 to 100 mg/l to below 30 mg/l.

PHYSICAL DESIGN OF PONDS. In general, rectangular ponds with length to breadth ratios of 2 or 3 to 1 and embankment slopes of 1 in 3 are used wherever possible. The embankment is protected from erosion by wave action by placing precast concrete slabs or stone riprap at surface water level.

The pond base should be impermeable. In coarse permeable soils, the pond base should be sealed with plastic sheeting or clay.

The inlet and outlet structures should be as simple as possible; a wide variety of low-cost designs is avail-

able. For all ponds, V-notch weirs, rectangular weirs, or, if necessary, Parshall flumes may be installed to measure influent and effluent flows as required for performance evaluation.

Typical layouts and details are shown in figures 21-1 through 4. Sample design calculations are given in the following paragraphs.

Assume a population (P) of 100,000, a BOD_5 contribution of 40 gcd, and a wastewater flow of 80 lcd. The design temperature is 20°C. The design concentration of fecal coliforms in the final effluent is to be 100 per 100 ml. The sewage is to be treated by anaerobic, facultative, and maturation ponds operating in series.

1. Anaerobic ponds:

$$\begin{aligned} \text{Flow, } Q &= 80 \times 10^{-3} \times 100,000 \\ &= 8,000 \text{ m}^3/\text{d}. \end{aligned}$$

$$\begin{aligned} \text{Influent } BOD_5, L_i &= (40 \times 10^3)/80 \\ &= 500 \text{ mg/l}. \end{aligned}$$

Taking λ_v as 250 g/m³/d, the volume (V) is given by:

$$\begin{aligned} V &= L_i Q / \lambda_v \\ &= 500 \times 8,000 / 250 = 16,000 \text{ m}^3. \end{aligned}$$

If the depth is 3 m, the area would be 0.53 ha. The hydraulic retention time ($= V/Q$) is two days, so that the BOD_5 removal would be around 60 percent. Desludging would be required every n years, where n is given by:

$$\begin{aligned} n &= \frac{V/2}{P \times 0.04} \\ &= \frac{16,000/2}{100,000 \times 0.04} = 2. \end{aligned}$$

This assumes a sludge accumulation rate of 0.04 m³ per person yearly and that the pond is desludged when it is half full of sludge.

2. Facultative ponds:

From equation (21.4) the area (A) is given by:

$$\begin{aligned} A &= \frac{L_i Q}{2T - 12} \\ &= \frac{(500 \times 0.4) \times 8,000}{(2 \times 20) - 12} = 57,000 \text{ m}^2 \text{ or } 5.7 \text{ ha}. \end{aligned}$$

If the depth is 1.5 m, the volume would be 86,000 m³ and the retention time eleven days. Assuming a

conservative BOD_5 removal of 70 percent, the effluent BOD_5 would be 60 mg/l.

3. Maturation ponds:

For N_e approximating 100 per 100 ml, try three maturation ponds, each with a retention time of five days:

$$\begin{aligned} N_e &= \frac{N_i}{(1 + K_{brT}t_{an}^*) (1 + K_{brT}t_{in}^*) (1 + K_{brT}t_{mat}^*)^3} \\ &= \frac{10^8}{[1 + (2.6 \times 2)] [1 + [2.6 \times 11]] [1 + (2.6 \times 5)]^3} \\ &= 200. \end{aligned}$$

This value is too high. Repeating the calculation, assuming three ponds with six and one-half days of retention each, gives a value for N_e of 95, which is satisfactory. The area (A) of each pond, assuming a depth of 1.5 m, is given by:

$$\begin{aligned} A &= Qt^*/D \\ &= 8,000 \times 6.5/1.5 = 35,000 \text{ m}^2. \end{aligned}$$

Thus, the total working area of the pond system is approximately 17 ha. The total retention time is thirty-two and one-half days; since this is greater than twenty days, the effluent will be completely free of helminth eggs, larvae, and protozoan cysts. If the anaerobic pond were not included in the design, the required area would be 25 ha (for one facultative pond of twenty-seven days' retention and four maturation ponds each of five days' retention).

Night-soil treatment ponds

Assume a population of 100,000, a night-soil production of 8 lcd (including PF water), a night-soil BOD_5 of 5,000 mg/l and a temperature of 20°C.

Equations (21.1) through (21.3) are used for the design of anaerobic and facultative ponds. Design computations are as follows.

1. Anaerobic ponds:

$$\begin{aligned} \text{Flow, } Q &= (8 \times 10^{-3} \text{ m}^3/\text{c/d}) \times 100,000 \text{ people} \\ &= 800 \text{ m}^3/\text{d}. \end{aligned}$$

$$BOD_5, L_i = 5,000 \text{ mg/l}.$$

Assume $\lambda_v = 250$ g/m³/d as in previous example.

From equation (21.1):

$$V = L_i Q / \lambda_v = (5,000 \times 800) / 250 = 16,000 \text{ m}^3.$$

For a depth, d , of 3 m, $A = 0.53$ ha.

Detention time = 20 days (assuming evaporation = precipitation).

Assuming 75 percent removal, the effluent $BOD_5 = 1,250$ mg/l.

Figure 21-6. Alternative Flow Diagrams for Composting Night Soil by BARC System

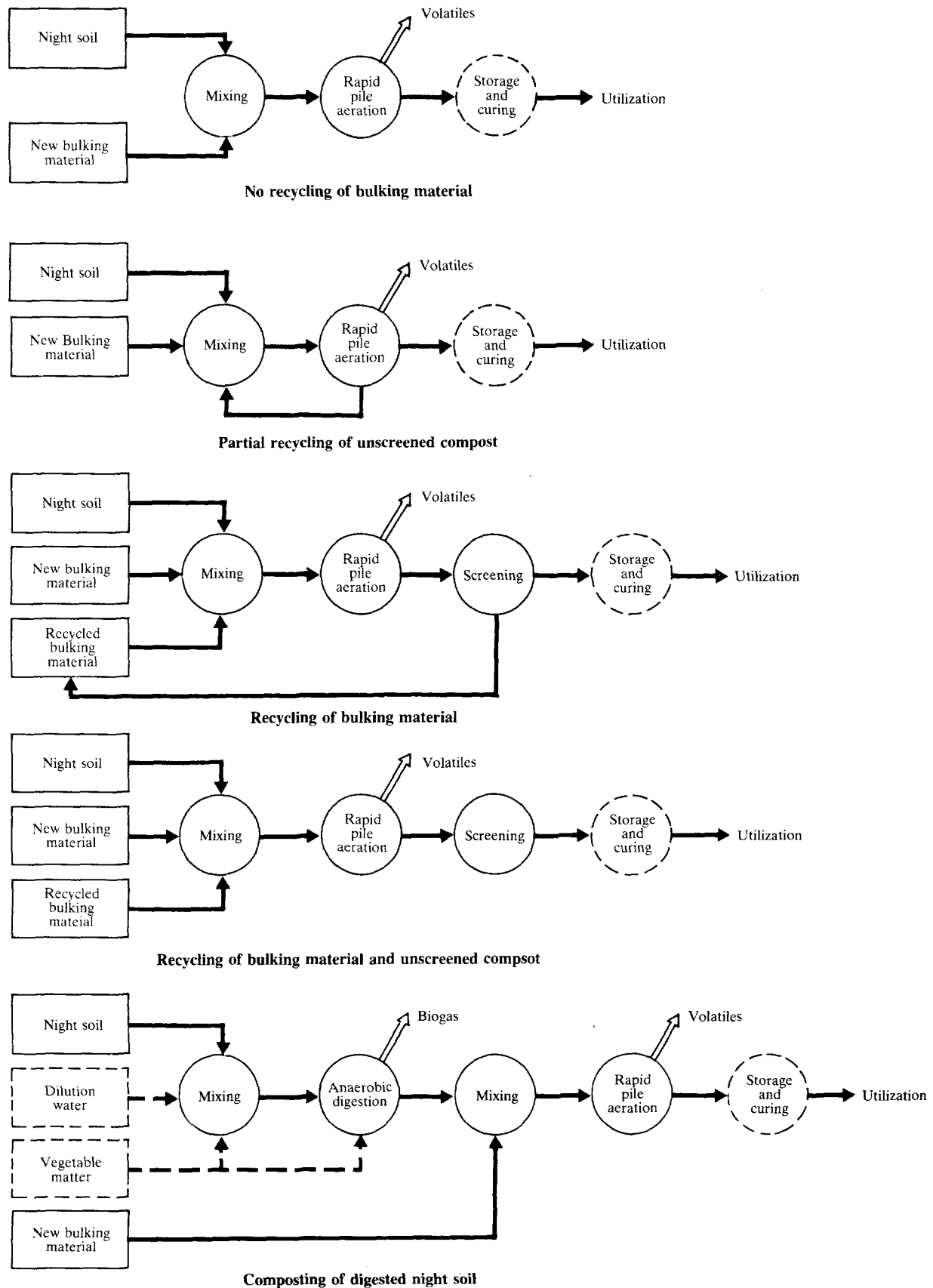

2. Facultative ponds:

From equation (21.3), maximum BOD₅ loading,
 $\lambda_s = 20T - 120 = (20 \times 20) - 120$
 $= 280 \text{ kg/ha/d.}$

From equation (21.2), area (A) of pond:

$$A = \frac{10 \times (0.25 \times 5,000 \text{ mg/l}) \times 800 \text{ m}^3/\text{d}}{280 \text{ kg/ha/d}} = 35,714 \text{ m}^2$$

For $d = 001.5 \text{ m}$, $V = 53.6 \text{ m}^3$,
 and detention time = 67 days.

Note that if daily evaporation equals or exceeds
 $800 \text{ m}^3/\text{d} \div 3.57 \text{ ha} = 22.4 \text{ mm/d}$, there will be
 no outflow.

Assuming 80 percent removal, the effluent BOD₅
 $= 250 \text{ mg/l.}$

The minimum area of a second facultative pond
 is:

$$A = \frac{10 \times 250 \text{ mg/l} \times 800 \text{ m}^3/\text{d}}{280 \text{ kg/ha/d}} = 7,143 \text{ m}^2$$

Assuming as above that evaporation = precip-
 itation, the retention time = $7,143 \text{ m}^2/800 \text{ m}^3/\text{d}$
 $= 9 \text{ days.}$

3. Maturation ponds:

A maturation pond with 5 days' detention
 would have a volume of $800 \text{ m}^3/\text{d} \times 5 \text{ d} = 4,000$
 m^3 . For a depth of 1 m, the area equals 0.4 ha.

A total pond area of about 5 ha would thus
 be needed to treat the excreta produced by a
 population of 100,000. If additional land is avail-
 able, it is often more convenient not to have an
 anaerobic pond so that the need to desludge it
 every 2 years can be avoided. In this case the
 facultative pond area (A) is given by equation
 (21.3) as:

$$\begin{aligned} A &= 10 L_t Q / \lambda_A \\ &= 10 \times 5,000 \times 80 / 280 \\ &= 14,285 \text{ m}^2 = 14.3 \text{ ha.} \end{aligned}$$

The retention time, assuming a depth of 2 m (to
 allow for additional sludge storage capacity), is 358
 days—nearly a year. Make-up water would be re-
 quired to maintain the depth when the daily evap-
 oration exceeds 5.6 mm.

The kinetics of BOD removal in night-soil ponds
 have not been studied, and so it is difficult to estimate
 with any precision the BOD₅ of the effluent. A con-
 servative estimate, based on BOD removal in ponds
 treating domestic sewage, is that the effluent BOD₅

would be in the range of 40 to 100 mg/l. Further
 treatment in a small maturation pond with a reten-
 tion time of ten to twenty days might therefore be
 required if the effluent is to be discharged into a
 small watercourse. Since the facultative pond ef-
 fluent would be completely free of excreted patho-
 gens, however, further treatment would not be re-
 quired if the effluent is to be reused in aquaculture
 or agriculture. Some caution is needed in the agri-
 cultural reuse of night-soil pond effluent because it
 may contain too high a concentration of dissolved
 salts, especially sodium. The available evidence is
 that chloride and sodium concentrations in night-soil
 pond effluents are in the range of 200 to 300 mg/l
 and 140 to 330 mg/l respectively, which compares
 well with concentrations of 100 to 660 mg/l and 60
 to 360 mg/l respectively in effluents from ponds treat-
 ing domestic sewage. In areas where evaporation
 greatly exceeds precipitation, however, make-up
 water may be necessary to prevent build-up of salts
 to concentrations that inhibit algae growth.

Night-soil treatment ponds have two additional
 requirements over ponds treating sewage. First,
 there must be an adequate source of water locally
 available to replace evaporation losses. River water
 is normally suitable. Second, there must be unloading
 facilities for the night-soil tankers. The design
 should include a manually raked medium screen (for
 example, 10-mm bars with 20-mm spacings), a night-
 soil pond with a capacity twice that of the largest
 night-soil tanker used, and a macerating pump that
 should discharge below the pond surface water level
 and approximately 10 to 20 m away from the em-
 bankment. Provision should be made for the night
 soil to flow by gravity directly into the pond when
 the pump is under repair.

Beltsville aerated pile composting system

Flow diagrams presented in figure 21-6 are based
 on mixing each volume of night soil or sludge with
 two volumes of woodchips, straw, rice hulls, ground-
 nut hulls, leaves, or other carbonaceous bulking
 material that has a low moisture content of, say, 30
 percent.³ Finished composts can also be used. During
 mixing, temporary odors are usually produced. Mix-
 ing can be done by turning with a Fresno scraper,
 roadgrader, front-end loader, or other machine. The
 final mix should be similar to the consistency of stiff
 concrete.

The purpose of the bulking material is to: (1) re-
 duce the moisture content of the mixture to 40 to 60
 percent; (2) provide structure or porosity for air

movement through the mixture; and (3) provide carbon to raise the carbon-to-nitrogen (C:N) ratio to approximately 20 to 30 to 1. This C:N ratio of sewage sludge is in the range of 9 to 15 to 1. Raising the C:N ratio reduces the loss of nitrogen as ammonia. The addition of carbon as a bulking material ensures the conversion of nitrogen into organic constituents of the biomass.

THE AERATED PILE. A three-dimensional schematic diagram of the Beltsville⁴ aerated pile method for composting night soil in sewage sludge is shown in figure 21-6. In their simplest form the individual, stationary, aerated piles are constructed as follows:

- A loop of 4-inch (10-cm) diameter perforated plastic pipe is placed on the composting pad, and oriented lengthwise, directly under what will become the ridge of the pile. Perforated steel pipe can also be used and later removed for reuse. The perforated pipe should not extend under the end slopes of the pile because excessive amounts of air may be pulled through the sides, causing localized zones that do not reach the thermophilic range (that is, "cold spots"). The pipe should be placed at least 2.5 to 3 m from the ends of the pile.
- Woodchips (or other bulking material) are placed over the area to be covered by the pile in a layer that will cover the pipes by a depth of at least 3 to 5 cm. This layer forms the pile base and facilitates the movement and distribution of air during composting. The base material also absorbs excess moisture that may condense and leach from the pile.
- The mixture of sludge and woodchips is then placed loosely upon the prepared base (with a front-end loader or conveyor system) to form a pile, with a triangular cross-section, 5-m to 7.5-m wide and 2.5-m high (see figure 21-5).
- The pile is completely covered with a 30-cm layer (often referred to as the "blanket") of cured, screened compost. The blanket layer provides insulation and prevents the escape of malodorous gases during composting. If finished compost is not available, as would be the case for the first piles of a new operation, the bulking material itself can be used for this purpose. The blanket thickness may have to be increased, however, to achieve the same degree of insulation and odor control as obtained with cured compost.
- During construction of the pile base, the perforated pipe is connected to a section of solid

plastic pipe that extends beyond the pile base. The solid pipe is connected through a moisture trap and thence to a ½-horsepower blower controlled by a timer. Condensate draining from the moisture trap should be discharged to a sewer or a soakaway. Aerobic composting conditions are maintained by drawing air through the pile intermittently. The exact aeration schedule will depend on pile geometry and the amount of sludge to be composted. For a pile containing up to 80 tons of sludge (20 m × 5 m × 2.5 m), the timing sequence for the blower is five minutes on and fifteen minutes off.

- The effluent air stream from the compost pile is conducted into a small cone-shaped pile of cured, screened compost approximately 1.2 m high and 2.5 m in diameter, where malodorous gases are effectively absorbed. These are commonly referred to as odor filter piles. The moisture content of compost used for this purpose will increase slowly. A 10-cm base layer of woodchips or other bulking material under the odor filter pile will minimize back pressures that could cause leakage of malodorous gases around the blower shaft and will absorb excess moisture. Research has shown that the odor filter pile should contain about 0.75 cubic meter of screened compost for each 10 wet tons (4 dry tons) of sludge being composted. In the case of new operations, where screened compost is not yet available, some bulking materials or soil (or a mixture thereof) could be used in the filter piles.

Variations in pile shape and size can adapt the process to differences in the rate of sludge production by most treatment plants. The individual pile method described here has been used for operations of from 5 to over 100 tons per week of raw or digested sludge with 20 percent solids.

THE EXTENDED AERATED PILE. Another version of the aerated pile is the aerated extended pile. Each day's sludge production is mixed with a bulking material, and a pile is constructed that utilizes the slope (lengthwise dimension) of the previous day's pile, thus forming a continuous or extended pile. The extended pile offers certain advantages for larger municipalities. For example, the area of the composting pad can be reduced by about 50 percent compared with that required to accommodate an equal amount of material in individual piles. Moreover, the amount of blanket material (that is, screened compost) needed for insulation and odor control and the

amount of bulking material for the pile base are both decreased by half.

In constructing an extended pile, the first day's sludge production is placed in an individual pile with triangular cross-section as described earlier. The exception is that only one side and the ends are blanketed. The remaining side is dusted with about 2.5 cm of screened compost for overnight odor control. On the next day, an additional aeration pipe is placed on the pad surface parallel to the dusted side, the pile base is extended, and the sludge-woodchip mixture is placed in such a manner as to form an extended pile. On the second day, the flat top and ends are blanketed with screened compost and the remaining side receives a thin layer of compost as before. The pile is extended each day for twenty-eight days. After twenty-one days, however, the first day's section is removed for either drying and screening or placing in a curing pile. After the removal of seven sections in chronological sequence, there is sufficient space for operating the equipment so that a new extended pile can be started where the old one has been. Thereafter, a section is removed each day from the old pile and a section is added to the new one.

TEMPERATURES ATTAINED DURING COMPOSTING. The conversion of sludge into compost is essentially complete after three weeks in the aerated pile. Microbial decomposition of the volatile organic fraction of the sludge in an aerobic atmosphere soon raises the temperature throughout the pile to from 60° to 80°C, which effectively destroys pathogenic organisms that might cause diseases in human beings. Temperatures begin to decrease after about two and one-half weeks, and this indicates that the more decomposable organic constituents have been utilized by the microflora, stabilized, and transformed into compost. Studies in Maine and New Hampshire in the United States, and Ontario in Canada, have shown that neither cold weather nor snow affects composting.

AERATION AND OXYGEN SUPPLY. Centrifugal fans with axial blades are usually the most efficient machines for developing the necessary vacuum to move air through the compost piles and into the odor filter piles. A pressure differential of about 125 mm (water gauge) across the fan has been adequate when woodchips are used as the bulking material. When finer-textured materials such as sawdust are used, however, an increase in pressure differential will be required.

The aeration rate should maintain the oxygen level

in the pile between 5 and 15 percent for rapid decomposition of the sludge and extended thermophilic activity. This level has been achieved at Beltsville with an aeration rate of about 14 m³ per hour per dry ton of sludge obtained by intermittent operation of the blower. Continuous aeration results in rather large temperature gradients and cooling within the pile.

Four-inch (10-cm) flexible perforated plastic drainpipe has been used to collect the air under the piles and to deliver it to the odor filter piles. The pipe is damaged beyond reuse when the piles are taken down, but since it is relatively inexpensive it is regarded as an expendable item. Rigid steel pipe has also been used and can be pulled lengthwise out of the pile without damage and can be reused. The pipe spacing for the extended piles should not exceed the pile height. The pipe should be large enough so that friction losses will not cause a pressure differential of more than 15 percent along the length of the perforated section. Manifolding the outer ends of the pipe will equalize pressure in the event of accidental damage to the pipe.

CONDENSATE AND LEACHATE CONTROL. As air moves down through the composting sludge, it is warmed and picks up moisture. Temperatures near the base of the pile are slightly cooler as a result of heat loss to the ground. As the air reaches this area, it is cooled slightly, causing moisture to condense. When enough condensate collects, it will drain from the pile and leach material from the sludge. Condensation will also collect in the aeration pipes and, if not vented, can accumulate and block the air flow. The combined leachates and condensate may amount to as much as 20 liters daily per ton of dry sludge. If the bulking material is sufficiently dry to begin with, there will be no leachate drainage from the pile. The leachate can be a source of odor if it is allowed to accumulate in puddles, so it should be collected and handled in the same manner as runoff water from the site.

The physical and chemical characteristics of the final product can affect the agronomic or utilization value of the compost. Particle size can affect application systems. Fine particles of material can be applied with standard fertilizer spreaders, whereas coarse particles may require special equipment. The chemical characteristics will affect the quantity and the way the material can be used. The C:N ratio of the compost used as fertilizer should not exceed 30 to 1, since this will require additional supplemental nitrogen. Woodchips and other material of high C:N

ratio therefore need to be screened out if the product is to be used as a low-analysis fertilizer. If refuse is used as a bulking material, screening is needed to remove undesirable material.

CURING AND STORAGE. Compost should be cured for about thirty days (screened or unscreened). This may be done in the original pile with aeration turned off, or in a support pile. After airing, the compost may be used immediately or stored until demand for compost develops. Curing further stabilizes the compost. Use of the compost is ordinarily seasonal, with the bulk of it applied either at planting or harvest times. Thus, a curing and storage area is needed to accommodate three to six months' production.

During storage, the compost will continue to decompose at a slow rate. Even though compost is well stabilized, if it is stored in large piles at a moisture content above 40 percent, temperatures may increase to the thermophilic range, and additional composting will occur. This is no cause for concern; it may, in fact, actually improve the quality of the compost for some uses.

The compost can be stored without cover and may be piled as high as is convenient with the equipment available. Care should be taken to round the tops of the storage piles so that rain will run off and wet pockets will not develop.

MONITORING AND MANAGEMENT. Monitoring is essential to ensure proper operating conditions, high temperatures for pathogen reduction, and odor control. Operational monitoring can be kept at a minimum with low-cost, unsophisticated equipment.

Temperatures will reveal more about the process than any other single parameter. Most of the pile should reach 55°C within two to four days, a temperature that indicates satisfactory conditions with respect to moisture content, bulking material ratio, mixing, aeration, and pH.

Low average temperatures (below 60°C) can result from excessive aeration or too high a moisture content. The former can be corrected by reducing the blower cycle or placing a baffle in the pipe just in front of the blower. If the moisture content is too high, it indicates an improper sludge-to-bulking material ratio in the mix. The pile can then be torn down and rebuilt with additional bulking material and future piles built with the correct ratio. Cold spots in the pile may also result from improper pipe spacing or an inadequate insulation cover. Temperature monitoring should be done daily for the first

week. Once temperatures peak at the desired level, only periodic spot checks are needed. Bimetallic probe thermometers are appropriate for such checks.

ODORS. Although night-soil sludge can emit a strong, unpleasant odor initially, odor disappears quickly as the sludge is aerated. Each of the unit operations can be a potential source of odors. Some of the odors emitted are intermittent, whereas others are continuous. Odor potential increases considerably during and immediately following periods of excessive precipitation.

To minimize the odor potential throughout the composting process, it is essential to manage each operation as follows:

- **The mixing operation:** Prompt mixing of sludge and bulking material and placement of the mixture in the aerated pile reduces the time for odor generation.
- **Aerated pile surface:** This will not be a source of strong odors if the blanket of compost is adequate for insulation. Thin spots or holes in the blanket will be a potential source of odors. The effectiveness of the blanket for odor control decreases when its moisture content exceeds 60 percent.
- **Air leakage between the blower and odor filter pile:** Since air leakage can occur at this point, all joints should be sealed. Back pressure from the odor filter pile should be minimized to prevent loss of gases around the blower shaft. Back pressure can be reduced by placing a 4- to 6-inch layer of bulking material under the filter pile; it will increase as the moisture content of the pile increases.
- **Odor filter piles:** As mentioned earlier, the odor filter piles are a potential source of odors. They should be cone shaped, symmetrical, and contain about 0.75 m³ of dry (40 percent moisture or less) screened compost per 10 wet tons of sludge being composted.
- **Condensate and leachate:** These are potential sources of odors. As these liquids drain from the compost pile, they should be collected into a sump and piped to a soakaway or stabilization pond.
- **Removal of compost from the aerated pile to the curing pile:** If the sludge has not been adequately stabilized before this operation, odors will be released. Excessive odor during this operation can probably be attributed to too high

a moisture content in the composting mixture and can be avoided by lowering the moisture content of the mix with additional bulking material.

- **Curing pile:** This can be a source of odors when the material removed from the aerated pile has not been completely stabilized. The use of drier materials in the initial mixing operation will prevent this problem. Blanketing the curing pile with dry cured compost will also help to contain any odors. Where night soils or sludges are incompletely composted after twenty-one days because of excess moisture, low temperatures, or improperly constructed piles, the odor potential will be high. In these cases, the sludge should not be put on a regular curing pile but should be mixed with additional bulking material and composted another twenty-one days (or put into a separate isolated pile, heavily blanketed with screened compost, and allowed to compost for several months).
- **Storage piles:** Odors would arise only if the piles were constructed with excessively wet compost.
- **Aggregates or clumps of night soil or sludge:** When aggregates of night soil or sludge, even though small in size, are allowed to remain on the compost pad after mixing and processing, they can soon emit unpleasant odors. Workers should be made aware of this possibility so that all aggregates of night soil or sludge are carefully removed from the mixing area as soon as possible.
- **Ponding of rainwater:** When rainwater is allowed to pond on the site, anaerobic decomposition can occur and cause unpleasant odors. Therefore, the site must be graded and compost piles located so that ponding will not occur.

SITE DESIGN. The compost site should be located as close as possible to existing wastewater treatment or other waste disposal facilities. The advantages are: (1) low sludge hauling and transport costs; (2) use of existing institutions and infrastructure; and (3) combined composting of night soil, sewage, treatment sludge, and septic tank sludge.

The site should be located away from residential areas, with easy access for transport and removal of the product. This may be adjacent to a rail line or river barge facility if the product is to be transported to remote agricultural areas.

The design of facilities should take into consideration climate (especially precipitation and wind

and soil conditions. In areas where precipitation is high or distributed over the entire year, some cover may be needed for the various operations. These areas may also require a stable site underlain by concrete or asphalt. Separate surface drainage systems may be needed.

In dry or subhumid climates cover is not essential. Operations have been composting in the open without any problems. A stable base is recommended, however, where muddy conditions make it difficult to operate equipment and provide a potential for odors.

A sludge-composting facility should comprise the following areas: (1) receiving and mixing; (2) composting pad; (3) drying and screening; (4) compost curing and storage; (5) storage of bulking material; (6) administrative and maintenance; and (7) runoff collection and disposal.

As indicated earlier, several of these areas may not be needed. The administrative, parking, and maintenance area may already be part of an existing facility. A runoff collection system may not be needed if the runoff can be channeled into a sewer.

The areas that need to have a stable base are those for mixing, the composting pad, and screening. Materials that can be used for the base are gravel, crushed rock, asphalt, concrete, or fly ash. Concrete is the preferred material.

In arid areas with high winds, precautions need to be taken to avoid excessive dust. A shelter belt can

Table 21-1. *Equipment Needed for Night-Soil Composting*

Type of equipment	Specifications or model
Front-end loader	Rubber wheeled, with bucket and engine size according to size of operation
Options for mixing	
Tractor and rototiller	Standard farm equipment
Easy-over compost turner and tractor	Mounted on tractor
Pug mill	Mixing material needs to be fed into mill by conveyers, hoppers, and the like as required
Screens, trommel, or shaker	Specifications depend on capacity needed; 7- to 9-mm opening
Blowers, fans	1/3-horsepower; 9-inch (22-cm) centrifugal blower with nominal rating of 160 cubic feet per minute at 5 inches (4.5 m ³ per minute at 12.7 cm) static pressure
Thermometers	Bimetallic dial thermometers, or similar, with 30- and 60-cm probes

greatly reduce the wind velocity within the site. Unpaved areas may require watering to reduce dust.

Land area requirements are estimated at 1 ha for each 12 dry tons daily (total solids) of night soil or sludge. This will provide for mixing, piles, screening, drying, curing, and storage. If extended piles are used, the figure is about 1 ha for each 15 dry tons daily.

COMPOSTING EQUIPMENT. Equipment needed for a composting operation include: (1) front-end loader, (2) mixing equipment, (3) screening equipment, (4) blowers, and (5) thermometers. Brief descriptions are given in table 21-1.

Notes to Chapter 21

1. The Beltsville Agricultural Research Center (BARC), located in Beltsville, Maryland, is a facility of the U.S. Department of Agriculture.

2. Abbreviations for units of measure used in this appendix, in addition to the standard ones for metric units, are: gcd, gram(s) per capita daily; g/m³/d, gram(s) per cubic meter daily; kg/ha/d, kilogram(s) per hectare daily; l, liter(s); lcd, liter(s) per capita daily; m³/c/d, cubic meter(s) per capita daily; mg/l, milligram(s) per liter; mm/d, millimeter(s) daily.

3. This material is taken largely from the appendix by E. Epstein in Shuval, Gunnerson, and Julius (1980).

4. Beltsville Agricultural Research Center (BARC), U.S. Department of Agriculture, Beltsville, Maryland.

22

Resource Recovery

HUMAN EXCRETA, in whatever form, are a resource that may be conserved and reused rather than discarded. Excreta and sewage contain many essential nutrients for the growth of terrestrial and aquatic plants; often sewage is also a valuable source of irrigation water. The anaerobic digestion of excreta yields biogas, which can be used as a source of energy for cooking and lighting. Some form of treatment, however, is always required to reduce the health risks caused by excreted pathogens to an acceptable minimum. The only exception to this is biogas production, but if the digested sludge from the biogas generator is to be reused on the land, additional treatment or storage is necessary unless digestion occurred within the thermophilic temperature range.

There are three principal ways in which excreta and sewage can be reused: agricultural reuse, aquacultural reuse, and biogas production. There are, however, cultural, institutional, and occasional economic constraints to the reuse of excreta in many areas of the world. Cultural constraints are apparently based on religious custom (rather than religious law) and on aesthetics and convenience. Institutional constraints are found in various kinds of restrictive legislation and in the teaching and practice of conventional sanitation technologies based on systems in the industrial countries. Economic constraints to reuse have included availability of low-cost or subsidized chemical fertilizers; economic development in farming areas now makes the convenience of chemical fertilizers affordable to the farmer. In any event, the greatest concerns are usually those relating to infection by pathogens and parasites present in the wastes. Accordingly, much of this chapter is taken from Feachem and others (forthcoming), who have reviewed aspects of excreta-related infections. A schematic diagram of a number of possible reuse options is shown in figure 22-1.

Agricultural Reuse

Agricultural use is the most common form of excreta reuse, and in many ways the simplest. There may be risks of infection, however, to those who work in the fields and to those who consume the crops. The latter group includes both man and animals. There may also be problems associated with the chemical quality of the compost, sludge, or sewage effluent coming partly from industrial areas; for example, crops may concentrate heavy metals, and high sodium concentrations can damage the soil structure.

Excreted pathogens present in the wastes may reach the field. Different treatment technologies will remove different pathogens to differing degrees. Where sewage effluent is reused, the *only* treatment processes that will produce an effluent essentially free from pathogens include maturation ponds, waste stabilization ponds followed by maturation ponds, land application, or sand filtration, or conventional sewage treatment with effluent chlorination. Where sludge or night soil are reused, processes that will produce a pathogen-free material are storage or drying for a minimum of twelve months or thermophilic composting.

If pathogens are not removed by these processes, they will be carried to the field. The survival times in soil of excreted pathogens can be generalized as follows:

	<i>Survival time in soil</i>
Viruses	Up to 6 months, but generally less than 3 months
Bacteria	Up to 3 years, but generally less than 2 months
Protozoa	Up to 10 days, but generally less than 2 days
Helminths	Up to 7 years, but generally less than 2 years, with few viable after 12 months.

Figure 22-1. Reuse Potential of Wastes

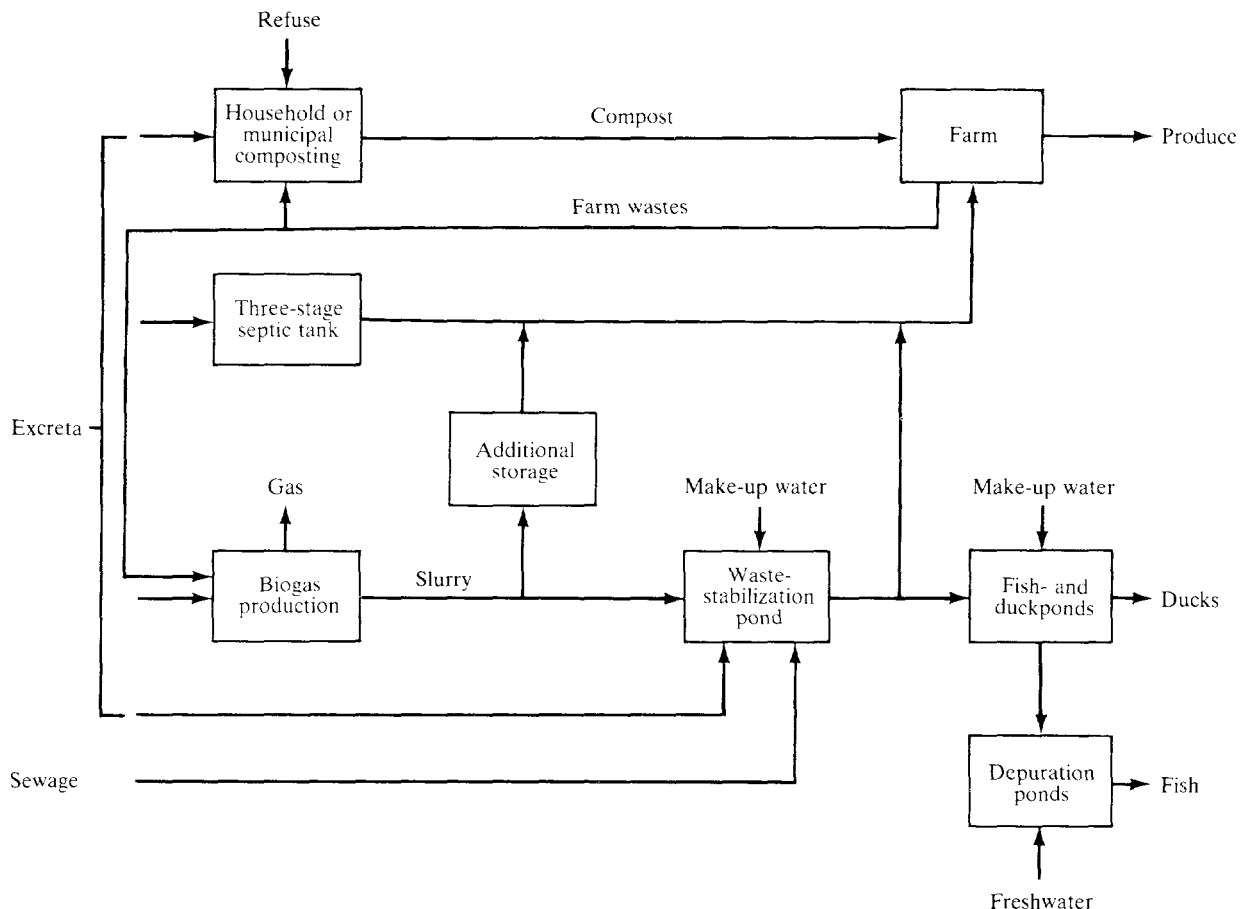

Whether the pathogens become attached to the surface of the crops depends upon the method of application and the crop. Crops grown on, near, or below the ground are most likely to become contaminated. Where wastes are sprayed or flooded on fields of growing crops, contamination is also certain. Crops may be protected by subsurface irrigation, by drip or trickle irrigation where crops are not on the ground, by irrigation through furrows not immediately adjacent to the crops, or by similar techniques. Alternatively, wastes may be applied only before planting, or application may be discontinued one month before harvesting begins, in view of the probability that the pathogens will die before the crops are harvested (see on-crop survival times, below). These methods are effective in preventing crop contamination when the applied waste has been properly treated. When a waste rich in pathogens is reused, however, pathogens are likely to reach the crops in significant numbers despite these protective measures.

Once on the crop, pathogen survival is not very long compared with survival in soil. Survival of excreted pathogens on crop surfaces may be summarized as follows:

	<i>Survival time on crops</i>
Viruses	Up to 2 months, but generally less than 1 month
Bacteria	Up to 6 months, but generally less than 1 month
Protozoa	Up to 5 days, but generally less than 2 days
Helminths	Up to 5 months, but generally less than 1 month.

The factors most lethal to pathogens are desiccation and direct sunlight. Survival may be expected to be considerably shorter in dry, sunny climates than in humid, cloudy climates.

Survival times are thus quite sufficient for at least some viable pathogens (except, perhaps, protozoa) to be transported into markets, factories, and homes, and subsequently to infect those who handle, process, prepare, or eat the crop. A distinction is sometimes made between crops that are eaten raw (tomatoes, for instance) and those that are normally

cooked (such as cabbage). Conservative public health policy, however, is to regard these similarly because, even if a cabbage, say, is eventually cooked, those who handle and prepare it are still at risk, and pathogens may be transferred to crops that are eaten raw.

There is much evidence to suggest that, where an excreted infection is highly endemic in a community and where poverty and squalor are found, the introduction of the particular pathogen into the home on contaminated vegetables or other crops has a negligible effect on transmission. Where excreted infections are not widespread in a community and where there are improved standards of hygiene and housing, however, the introduction of contaminated crops into the home may be the major transmission route for some excreted pathogens. This can be illustrated in the following way.

Imagine a town of moderately wealthy people who live in houses with water connections and flush toilets. Outside this town there is a village where people are extremely poor, houses have earth floors, water is drawn from an open well, and there is no adequate excreta disposal system. The main source of income for these villagers is the cultivation of vegetables for sale in the town. The villagers also use the vegetables themselves as a subsistence crop. These vegetables are fertilized by untreated excreta collected in the village and by sewage sludge obtained free of charge from the treatment works on the outskirts of the town. Let us consider infection with *Ascaris lumbricoides*. The prevalence of ascariasis in the town is only 8 percent, and the principal means of entry of viable *Ascaris* ova into the home is on the vegetables bought from the villagers. Transmission among the wealthy townsfolk is not taking place because their excreta are flushed away, and high standards of hygiene prevail in the town. The prevalence of ascariasis in the village is 68 percent. Transmission occurs intensively in the village and particularly in the home. The house floor and yard are contaminated with viable ova from the feces of infected children. Most transmission is unconnected to the contaminated vegetables, which the villagers also eat. If the supply of contaminated vegetables suddenly ended, the transmission of ascariasis in the town would be reduced substantially, whereas the village would be unaffected.

There are also potential health risks to those who work in excreta-fertilized or sewage-irrigated fields. Limited epidemiological evidence indicates that those who work on sewage farms are at greater risk than others. Also, in many agricultural communities, practically the whole population works in the fields

at some time of the year, and so all may be exposed to the risk (although not equally so). The only sure way to protect the health of the agricultural workers is to use only wastes that have been properly treated.

Aerosols from sewage treatment plant operations and from spray irrigation with treatment plant effluents have been regarded as potential hazards to treatment plant and agricultural workers, respectively. Careful studies, however, have shown no differences in morbidity between these workers and the general population (Pahren and Jakubowski 1980).

An additional health problem is that associated with cattle that graze on sewage-irrigated pastures or that are fed fodder crops grown in excreta-fertilized or sewage-irrigated fields. Although the pathogens of a variety of animal diseases have been detected in sewage, they occur in very small numbers, and transmission of these diseases by sewage is of negligible veterinary import. The one principal exception to this is beef tapeworm (*Taenia saginata*). This helminth circulates between man and cattle and infection *only* continues when cattle eat *Taenia* eggs that humans have excreted. Therefore, any excreta disposal or reuse technology that brings cattle into direct contact with human excreta may promote the transmission of the disease unless adequate treatment is provided. *Taenia* ova are very hardy and are surpassed only by *Ascaris* ova in their ability to survive outside the host. They may survive in soil or on pasture for over six months. Their removal from sewage will require either the use of waste stabilization ponds or tertiary treatment in the form of sand filtration or lagooning. Removal from sludge requires either a thermophilic process or retention for approximately one year. The prevention of cattle's exposure to untreated human excreta is crucial because beef tapeworm is an important health problem in both man and cattle in areas in which the parasite is highly endemic.

To reduce health risks associated with the agricultural reuse of excreta and sewage, the wastes should be treated to the following standards for pathogens in sewage effluents:

	<i>Standard</i>
Fecal coliform bacteria	Less than 100 per 100 milliliters
Fecal streptococci	Less than 100 per 100 milliliters
Protozoa	Not applicable
Helminth ova and larvae	Not applicable

and in sludges and composts:

	<i>Standard</i>
<i>Ascaris</i> ova	200 per 100 grams and less than 5 percent viability

The standards for fecal coliform and streptococci may be relaxed to less than 1,000 per 100 milliliters if only fodder or industrial crops are irrigated. No figures are given for protozoa and helminths in effluents since 100 percent elimination can be confidently obtained if waste stabilization ponds with a total retention of twenty days or more are used, which is usually necessary to ensure the required removal of fecal bacteria. In areas where ascariasis is absent (such areas are rare in developing countries), the ova of either *Taenia saginata* or *Trichuris trichiura* or other appropriate helminth indicator organisms should be used.

Aquacultural Reuse

Human excreta can be used to promote the growth of aquatic plants and animals. This practice is termed aquaculture. Four main types of aquaculture are practiced:

- Freshwater fish farming
- Mariculture (the culture of marine animals such as fish, shellfish, and shrimp)
- Algal production
- Aquatic plant (macrophyte) production.

Of these, freshwater fish farming is the most common (especially in Asia) and also the easiest. Mariculture is by its nature restricted to coastal communities; it is not as widely practiced as freshwater fish farming. The production of microalgae and aquatic macrophytes has received considerable research effort, but current knowledge is still very limited. Algal harvesting involves complex and expensive processes that have yet to be demonstrated as technically and economically feasible in large operational ponds. Although practiced traditionally in a few parts of the world, the fertilization of aquatic macrophytes with excreta and sewage (and its converse, the treatment of excreta and sewage by aquatic macrophytes) are processes that have not yet been fully economically or technically evaluated.

Freshwater fish farming is the only aquacultural reuse process about which enough is known to consider it for widespread replication. Cultured fish are the major source of animal protein for many low-income communities in countries in the Far East, where the most common method of fishpond fertilization is the use of human and animal excreta. Engineers and others involved in sanitation program planning are strongly advised to consult with local fish farmers and other specialists before embarking

on the design of fishponds. Training of local personnel in the proper management of fishponds is also essential.

There are three distinct health problems associated with fish farming in excreta- or sewage-fertilized ponds:

- The passive transference of excreted pathogens by the fish, which become contaminated in the polluted water
- The transmission of certain helminths whose life cycles include fish as an intermediate host
- The transmission of other helminths with life cycles involving other pond fauna, such as the snail hosts of schistosomes.

The first of these problems is a cause for concern throughout the world, whereas the second and third apply only in areas where particular eating habits are found and where the helminths concerned are endemic.

Fish may passively carry human pathogens in their intestines or on their body surfaces, and these pathogens may subsequently infect people who handle, prepare, or eat the fish. There is little risk to fish eaters, except in areas where fish are eaten raw or partially cooked. Thorough cooking will destroy all excreted pathogens.

The second health problem associated with fish farming is the transmission of worms parasitic to man that have an intermediate fish host. The most important of these are *Clonorchis sinensis* (Oriental liver fluke) and the related species *Opistorchis viverrini* and *O. felinus*, which are the only species associated with excreta-fertilized fishponds. They are intensively transmitted where fish is eaten raw or only partially cooked. Cooking of fish must be thorough to kill the encysted larvae, and most fish preservation and pickling techniques have little effect. Where fish are grown in pretreated or presettled sewage, *Clonorchis* eggs will have been removed by sedimentation. *Clonorchis* eggs are fragile and die if stored for a few days in night soil. Seven days' storage prior to pond enrichment is a sound strategy for the control of this infection. It must be noted, however, that there are other important definitive hosts apart from man (such as dogs and cats), so that the control of human excreta may only partially reduce transmission.

To summarize, fish farming using excreta or sewage carries with it the hazard of passive carriage of a range of pathogens and, in some parts of the world, of *Clonorchis* transmission as well. Control measures are as follows:

- Enrich ponds only with settled sewage or stored night soil or sludge.
- Allow the fish to reside and depurate in clean water for several weeks prior to harvesting.
- Clear vegetation from pond banks to discourage snails, which are the first intermediate host of *Clonorchis*. This also eliminates other helminthiases involving snails, such as schistosomiasis.
- Promote good hygiene in all stages of fish handling and processing.
- Discourage the consumption of undercooked fish.

The adoption of all these control measures will eliminate, or reduce to an acceptable level, the health hazards associated with the aquacultural reuse of human wastes and so permit the production of valuable, pathogen-free protein at low cost.

Although the number of fish species that have been successfully grown in excreta- and sewage-fertilized ponds is large, two groups are the most important: carp and tilapia. There are several species of carp and tilapia, the most useful being those that feed directly off the microalgae that grow profusely in fertilized ponds; these include the silver carp (*Hypophthalmichthys molitrix*), the bigear (*Aristichthys novilis*), and the two tilapia, *Sarotherodon mossambicus* and *S. niloticus* (formerly called *Tilapia mossambica* and *T. nilotica*). In India different species of carp are used for fish farming; the four most important are *Catla catla*, *Cirrhinus mrigala*, *Labeo rohita*, and *L. calbasu*.

Yields of carp in fertilized ponds vary from 200 kilograms per hectare yearly in rural subsistence ponds to above 1,000 kilograms per hectare yearly in carefully managed commercial ponds; yields of tilapia are even higher, 2,000 to 3,000 kilograms per hectare yearly in well-maintained ponds. Tilapia are prolific breeders; to eliminate breeding in fishponds, which reduces yields, the ponds should be stocked with fish of only a single sex. This can be readily achieved by using hybrids of male *S. mossambicus* and female *S. niloticus*, a cross that produces only male fish. Fish yields can be increased by several techniques. Ducks can be reared on the ponds, and their feces provide additional nutrients for the pond algae. This increases fish yields by as much as 50 to 100 percent. Other species of fish that occupy different ecological niches in the pond can be introduced; for example, the common carp (*Cyprinus carpio*) and the grass carp (*Ctenopharyngodon idella*) feed primarily on benthic zooplankton and aquatic weeds, respectively. This process is known as "polyculture," and fish yields of up to 5,000 to 7,000 kil-

ograms per hectare yearly can be achieved, especially if supplemental feeding with grass, other vegetation, rice bran, groundnut cake, and the like is practiced.

Basically the construction and physical maintenance of fishponds is the same as that required for waste stabilization ponds. Depths are usually greater than 1 meter to prevent vegetation from emerging from the pond bottom; deep ponds (greater than 2 meters) are disadvantageous because there is little oxygen, and hence few fish, in the lower layers.

There is, however, little information available on the range of retention times that should be provided in fishponds fertilized with sewage effluent. Too short a retention time may waste nutrients, and with long retention times the nutrient supply may be insufficient for optimal yields of fish. The retention time depends on the mean doubling time of the algal species present and the grazing rate of the fish. In general, one to five days may be required, but this needs to be determined by experiment.

For ponds that are fertilized with stored excreta or with the effluent from a low-flow night-soil treatment pond, the retention time is unimportant. What matters is the correct rate of supply of nutrients; regular batch feeding on an empirically determined basis is recommended.

It is possible to grow carp and tilapia in maturation ponds. Yields are in the range 200 to over 1,000 kilograms per hectare yearly, depending on management (stocking density, frequency of harvesting). Facultative ponds should not be used for fish culture since the concentration of dissolved oxygen often falls, especially at night, to too low a level. Air-breathing fish such as catfish and snakeheads, however, can be grown in facultative ponds; considerable success has been obtained in India and southeast Asia with several species that are highly prized for their nutritional and supposedly therapeutic value.

The pacu, a species of freshwater fish found in the Amazon basin, is showing great promise in aquaculture systems. The pacu is both a filter feeder and a herbivore, can gulp air during periods of low dissolved oxygen, grows rapidly, and has a higher ratio of edible flesh to total body weight than other traditional species (50 percent versus 35 percent for carp). Use of this fish is still in the experimental stage, but all results look promising.

Health risks can be reduced to acceptable levels if the fish are transferred to clean water depuration ponds for several weeks prior to marketing.

Figure 22-2. Schematic of Typical Biogas Digesters (millimeters)

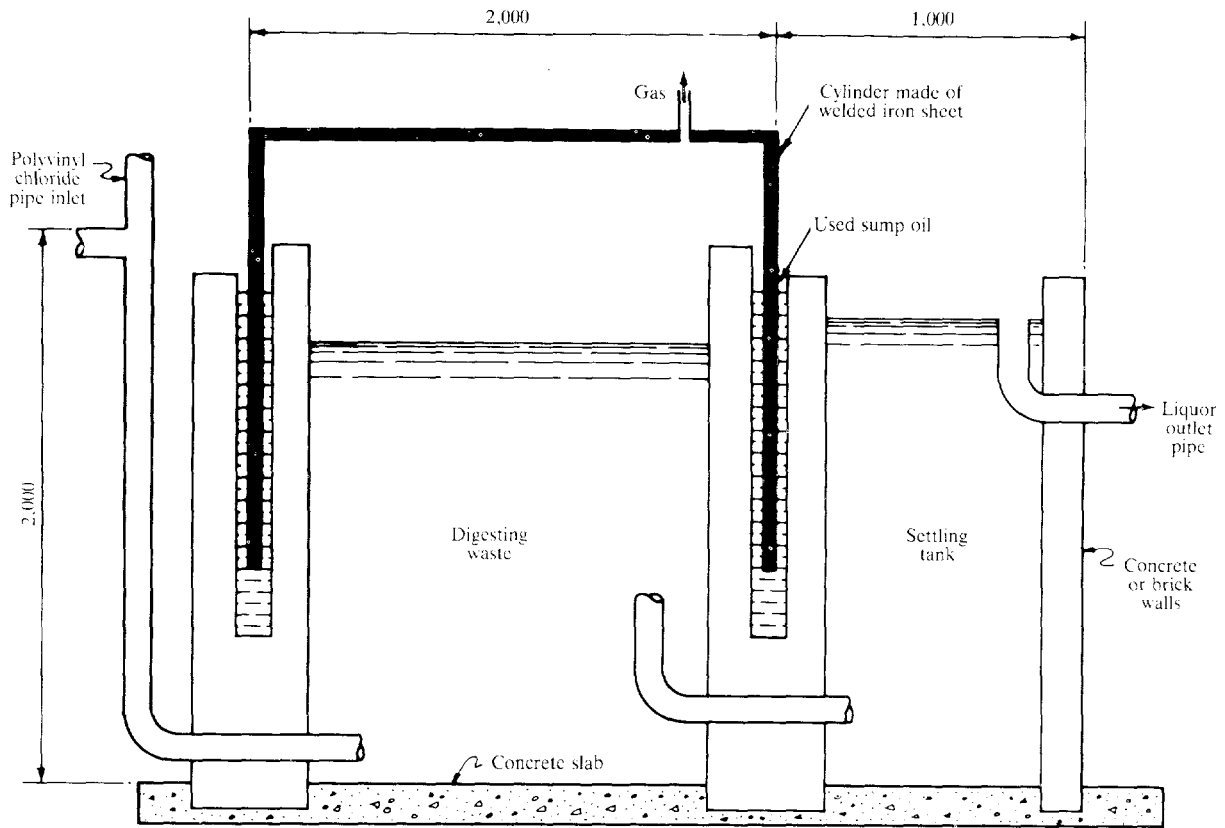

Floating metal gasholder

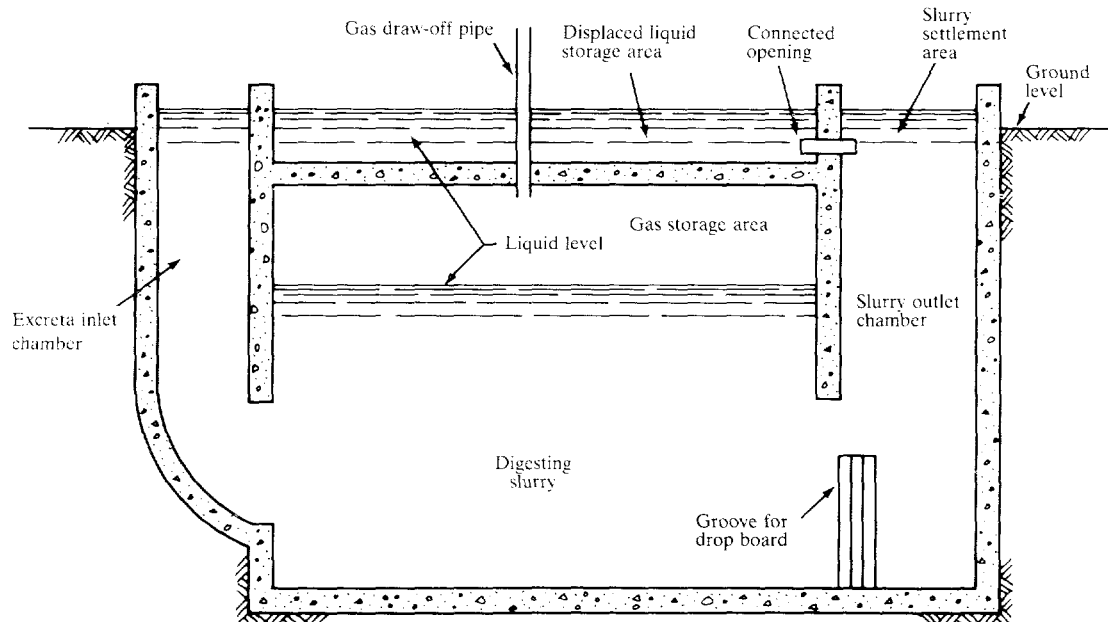

Chinese design

Biogas Production

When organic wastes are digested anaerobically, a mixture of methane, carbon dioxide, and other gases is given off. This gas has become known as "biogas" and can be produced on various scales by different technologies. In conventional sewage treatment works, anaerobic sludge digestion produces biogas that is sometimes used to heat the digesters or for some of the other energy needs of the works. The term "biogas production," however, is usually used to describe the production of methane on a small scale by individual farmers, communes, or rural institutions in developing countries.

Biogas plants are found in large numbers in China and India, and it is probably in these countries that the technology has become most developed. Significant numbers are also in operation in Korea and on the island of Taiwan. The units are fed with diluted animal feces, with or without human excreta and with or without vegetable refuse. The effluent slurry may be reused in agriculture, aquaculture, and as animal fodder. The gas is used primarily for domestic cooking and lighting. The dung from one medium-size cow, or similar animal, can produce around 500 liters of gas per day; it contains 50 to 70 percent methane, and its calorific value is around 4 to 5 kilocalories per liter. In contrast, human excreta yields only 30 liters of gas per person daily. The process is very sensitive to temperature. In the mesophilic range, optimal gas production occurs at around 35°C. In rural areas digesters are not heated, although they may be buried to conserve their heat, because gas production falls off at lower temperatures. Thermophilic digestion of feed-lot manures is under development in Israel and the United States.

There are several designs for rural biogas plants. Construction and operation requirements for some of the designs are presented by the U.S. National Academy of Sciences (1977). Two designs are shown in figure 22-2. The Chinese design is advantageous in that it contains no moving parts, avoids the need for a metallic gasholder (which has corrosion problems), and permits the gas to be stored at a relatively constant pressure.

The design of biogas plants is empirical. Loading rates vary between 0.5 and 3 kilograms of volatile solids per cubic meter of digester volume per day,¹ and retention times of five to thirty days are common. At the present time it seems prudent to adopt a retention time of thirty days as the controlling process design parameter. Gas production may be ex-

pected to be around a third to a half of the digester volume per day if the digester is operated semicontinuously (that is, fed daily or twice daily). Semicontinuous operation is preferable to batch feeding because the rate of gas production is fairly constant.

The material added to the biogas plant should have a C:N ratio in the range 10 to 30, and preferably 20 to 25. Night soil has a C:N ratio of 6 to 10 and so, for efficient operation of the unit, requires the addition of material with a high C:N ratio (such as leaves, grass, straw, or bagasse). Biogas units in rural areas are commonly designed for cow dung (which has a C:N ratio of 18 to 25), and the relatively small quantities of human excreta from a few households can be added without adverse effect. The feed material should have a solid concentration of about 10 percent, and thus some dilution is usually needed; one volume of animal dung is commonly diluted with one volume of water.

Social, Institutional, and Economic Aspects of Reuse

The health and technical requirements for a safe and productive resource recovery process have been described above. Much less is known about the equally important social and institutional requirements, and few good economic evaluations have been made for reuse schemes. The real test of any reuse product is whether it is demanded by, and can be delivered to, an ultimate consumer at a price he is willing to pay. The social and cultural factors that influence people's attitudes toward recycled waste products vary widely around the world and are not readily changed. Therefore it is imperative that a careful market study be carried out by behavioral scientists and economists before the development of schemes for resource recovery.

Reuse processes require careful planning and implementation to reduce the health risks to acceptable levels, to organize the delivery and retailing aspects as well as traditional collection and treatment tasks, and to provide for integrated systems in which multiple sources of wastes (such as animal dung and human night soil) can be managed to provide optimum multiple outputs (such as biogas, protein, and fiber). Demonstration projects may be needed to show farmers and officials alike that the known agricultural benefits of irrigation with raw sewage will be essentially retained by upgradeable treatment and irrigation systems which provide health benefits. Although well-run municipalities may be cost con-

scious and may attempt to minimize expenditure, they frequently lack the incentive and entrepreneurial skill to manage a revenue-producing operation successfully. Often it will be more advantageous for a municipality to contract excreta and sewage reuse processes to the private sector where these skills are more likely to exist.

It should be remembered, however, that the economically appropriate test of a reuse process is not that it make a positive profit, but only that its net cost be lower (in discounted cash flow) than that of other waste treatment and disposal alternatives with

or without reuse products. If the private sector is to be involved in the operation of the reuse scheme, this may mean that the municipality will have to pay the private firm a commission (based on the lowest competitive bid) rather than expect to sell a franchise.

Note to Chapter 22

1. Equivalent to approximately 6 to 40 kilograms of cow dung (wet weight) or 14 to 66 kilograms of night soil (wet weight) per cubic meter per day.

Bibliography

- American Society of Civil Engineers. 1977. *Wastewater Treatment Plant Design*. ASCE Manual of Practice no. 36. New York.
- Appleton, B. 1976. "Acid Test for Middle East Brain Drains," *New Civil Engineer* (February 19), pp. 23-29.
- Appropriate Technology*. 1979. Vol. 6, no. 3 (November).
- Arlosoroff, Saul. 1979. "Tradition and Innovation in Water Use and Reclamation." In Charles G. Gunner-son, and John M. Kalbermatten, eds., *Appropriate Technology in Water Supply and Waste Disposal*. New York: American Society of Civil Engineers, pp. 61-84.
- Assar, M. 1971. *Guide to Sanitation in Natural Disasters*. Geneva: World Health Organization.
- Bardach, J. E., J. H. Ryther, and W. O. McLarney. 1972. *Aquaculture: The Farming and Husbandry of Freshwater and Marine Organisms*. New York: Wiley.
- Barnet, A., L. Pyle, and S. K. Subramanian. 1978. *Biogas Technology in the Third World*. Ottawa: International Development Research Centre (IDRC).
- Blackmore, M., R. Boydell, N. Mbere, and P. Moselele. 1976-78. *Low-cost Sanitation Research Project: Interim Reports 1-3 and Final Report*. Gaborone, Botswana: Ministry of Local Governments and Lands.
- Canter, L. W., and A. J. Englande. 1970. *Journal of the Water Pollution Control Federation*, vol. 42. Cited in Mara (1976, p. 137).
- Clare, H. C., and others. 1961. In *Proceedings of a Symposium on Waste Stabilization Lagoons, Kansas City, 1960*. Washington, D.C.: U.S. Public Health Service. Cited in Mara (1976), p. 138.
- Central Public Health Engineering Research Institute (CPHERI). 1971. *Health Status of Sewage Farm Workers*. Technical Digest no. 17. Nagpur, India.
- "Directory of Composting Systems," *Compost Science/Land Utilization*, vol. 20, no. 1, pp. 22-25.
- Cotteral, J. A., and D. P. Norris. 1969. "Septic Tank Systems," *Journal of the Sanitary Engineering Division, American Society of Civil Engineers*, vol. 95, pp. 715-46.
- Elmendorf, Mary, ed. 1980. *Appropriate Technology for Water Supply and Sanitation*, vol. 8, *Seven Case Studies of Rural and Urban Fringe Areas in Latin America*. Washington, D.C.: World Bank.
- Elmendorf, Mary, and Patricia K. Buckles. 1980. *Appropriate Technology for Water Supply and Sanitation*, vol. 5, *Sociocultural Aspects of Water Supply and Excreta Disposal*. Washington, D.C.: World Bank.
- Feachem, Richard G. 1976. "Appropriate Sanitation," *New Scientist*, vol. 69, pp. 69-80.
- Feachem, Richard G., Michael G. McGarry, and David Duncan Mara. 1977. *Water, Wastes, and Health in Hot Climates*. New York: Wiley.
- Feachem, Richard G., and Sandy Cairncross. 1978a. *Small Excreta Disposal Systems*. Ross Bulletin no. 8. London: Ross Institute Information and Advisory Service.
- 1978b. *Small Water Supplies*. Ross Bulletin no. 10. London: Ross Institute Information and Advisory Service.
- Feachem, Richard G., D. Duncan Mara, and Kenneth O. Iwugo. 1980. *Appropriate Technology for Water Supply and Sanitation*, vol. 7, *Alternative Sanitation Technologies for Urban Areas in Africa*. Washington, D.C.: World Bank.
- Feachem, Richard G., David J. Bradley, Hemda Garelick, and D. Duncan Mara. 1980. *Appropriate Technology for Water Supply and Sanitation*, vol. 3, *Health Aspects of Excreta and Sullage Management: A State-of-the-Art Review*. Washington, D.C.: World Bank.
- . Forthcoming. *Sanitation and Disease: Health Aspects of Excreta and Wastewater Management*. World Bank Studies in Water Supply and Sanitation no. 3. Baltimore, Md.: Johns Hopkins University Press.
- Gloyna, E. G. *Waste Stabilization Ponds*. 1975. Geneva: World Health Organization.
- Hinghaugh, G. M. A. 1973. "Night-soil Treatment (on Lagos Island)," *The Consulting Engineer*, vol. 9, pp. 47-48.
- Jenkins, S. H., ed. 1973. "Sanitation and Low-cost Housing." In *Water Quality: Management and Pollution Control Problems*. Oxford: Pergamon Press, pp. 115-25.
- Kalbermatten, John M., DeAnne S. Julius, and Charles

- G. Gunnerson. 1982. *Appropriate Sanitation Alternatives: A Technical and Economic Appraisal*. World Bank Studies in Water Supply and Sanitation no. 1. Baltimore, Md.: Johns Hopkins University Press.
- . *Appropriate Technology for Water Supply and Sanitation*, vol. 1, *Technical and Economic Options*. Washington, D.C.: World Bank.
- Kilma, W., E. K. Simbeye, and U. Winblad. 1978. *Alternative Waste Disposal Methods, Tanzania, 1975–77: Final Report*. Dar es Salaam, Tanzania: National Scientific Research Council.
- Kuhlthau, Richard A., ed. 1980. *Appropriate Technology for Water Supply and Sanitation*, vol. 6, *Country Studies in Sanitation Alternatives*. Washington, D.C.: World Bank.
- Kumpf, E. H. W., K. Maas, and H. Straub. 1964–80. *Müll- und-Abfallbeseitigung*. Bielefeld, Germany: Erich Schmidt Verlag.
- Laak, R., K. Healey, and D. Hardistry. 1974. "Rational Basis for Septic Tank Design," *Groundwater*, vol. 12, pp. 348–52.
- Mara, D. Duncan. 1976. *Sewage Treatment in Hot Climates*. London: Wiley.
- Marais, G. V. R. 1974. "Fecal Bacterial Kinetics in Stabilization Ponds," *American Society of Civil Engineers, Journal of Environmental Division*, vol. 100, no. EE1, pp. 119–93.
- McGarry, Michael G. 1975. *Developing Country Sanitation*. Ottawa: IDRC.
- McGarry, Michael G., and M. B. Pescod. 1970. *Proceedings of the Second International Conference on Waste Treatment Lagoons, Kansas City*.
- McGarry, Michael G., and J. Stainforth. 1978. *Compost, Fertilizer, and Biogas Production from Human and Farm Wastes in the People's Republic of China*. Ottawa: IDRC.
- Metcalf and Eddy, Inc. 1975. *Wastewater Engineering: Collection, Treatment, and Disposal*. New York: McGraw-Hill.
- Mohanrao, G. J. 1973. "Waste Collection, Treatment, and Disposal in India," *Indian Journal of Environmental Health* (CPHERI, Nagpur), vol. 15, no. 3, pp. 222–35.
- National Academy of Sciences (U.S.). 1976. *Making Aquatic Weeds Useful: Some Perspectives for Developing Countries*. Washington, D.C.
- . 1977. *Methane Generation from Human, Animal, and Agricultural Wastes*. Washington, D.C.
- National Environmental Engineering Research Institute (NEERI). 1972. *Night-soil Wheelbarrows*. Technical Digest no. 32. Nagpur, India.
- Okun, Daniel H., and G. Ponghis. 1975. *Community Wastewater Collection and Disposal*. Geneva: World Health Organization.
- Pacey, A., ed. 1978. *Sanitation in Developing Countries*. London: Wiley.
- Pahren, H., and W. Jakubowski, eds. 1980. *Wastewater Aerosols and Disease: Proceedings of a Symposium, Sept. 19–21, 1979*. U.S. Environmental Protection Agency, EPA-600/9-80-028. Springfield, Va.: National Technical Information Service.
- Pradt, L. A. 1971. "Some Recent Developments in Night-soil Treatment (in Japan)," *Water Research*, no. 5, pp. 507–21.
- Raman, V. 1975. *Sanitation Facilities for Slums and Rural Areas*. Nagpur, India: NEERI.
- Raman, V., and N. Chakludor. 1972. "Upflow Filters for Septic Tank Effluents," *Journal of the Water Pollution Federation*, vol. 44, no. 8, pp. 1552–60.
- Rybczynski, Witold, Chongrak Polprasert, and Michael G. McGarry. 1978. *Low-cost Technology Options for Sanitation: A State-of-the-Art Review and Annotated Bibliography*. Ottawa: IDRC.
- Saunders, Robert J., and Patrick C. Mann. 1977. *Alternative Concepts of Marginal Cost for Public Utility Pricing: Problems of Application in the Water Supply Sector*. World Bank Staff Working Paper no. 259. Washington, D.C..
- Shaw, V. A. 1963. "A System for the Treatment of Night-soil and Conserving-tank Effluent in Stabilization Ponds," *Public Health* (Johannesburg), vol. 63, pp. 17–22.
- Shuval, Hillel I., Charles G. Gunnerson, and DeAnne S. Julius. 1980. *Appropriate Technology for Water Supply and Sanitation*, vol. 10, *Night-soil Composting*. Washington, D.C.: World Bank.
- South Australia Department of Public Health. 1968. *Septic Tank Effluent Drainage Schemes*. Public Health Inspection Guide no. 6. Norwood, South Australia.
- Squire, Lyn, and Herman G. van der Tak. 1975. *Economic Analysis of Projects*. Baltimore, Md.: Johns Hopkins University Press.
- U.S. Environmental Protection Agency. 1973. *Water Quality Criteria*. Washington, D.C.: U.S. Government Printing Office.
- . 1977. *Health Effects of Nitrates in Water*. EPA Report no. EPA-600/1-77-30. Washington, D.C.: U.S. Government Printing Office.
- U.S. Public Health Service. 1957. *Manual of Septic Tank Practice*. Public Health Service Publication no. 526. Washington, D.C.: U.S. Government Printing Office.
- Wagner, E. G., and J. N. Lanoix. 1958. *Excreta Disposal for Rural Areas and Small Communities*. World Health Organization Monograph Series no. 39. Geneva.
- White, Ann E., and Gilbert F. White. 1978. "Behavioral Factors in the Selection of Technologies." In Charles G. Gunnerson and John M. Kalbermatten, eds., *Appropriate Technology in Water Supply and Waste Disposal*. New York: American Society of Civil Engineers, pp. 31–51.
- Winblad, U., W. Kilama, and K. Tortensson. 1978. *Sanitation without Water*. Stockholm: Swedish International Development Authority.

Winneberger, J. H. 1974. *Manual of Graywater Treatment Practice*. Ann Arbor, Michigan: Ann Arbor Science Publishers.

World Bank. 1980. *Water Supply and Waste Disposal*. Poverty and Basic Needs Series. Washington, D. C.



Index

Page numbers in italics indicate tables or illustrations

- Aerated composting pile, 138, 139, 140
Aerated lagoons, 111
Aerosols from sewerage treatment plant, 147
Africa. *See* North Africa
Agricultural re-use of wastes, 145–48
Algal production, 148, 149
Amebiasis control measures, 19. *See also* Protozoa
Anal cleansing: aquaprivy and materials used for, 99; choice of fixtures and, 61; disposal of materials used for, 45, 64; PF toilets and materials used for, 99
Ancylostoma duodenale, 13, 14. *See also* Hookworm
Appropriate technology: defined, 5; economic and financial aspects of choosing, 27–35; planning and, 23. *See also* Technology
Aquacultural re-use of wastes, 148–50
Aquaprivies: advantages and disadvantages of, 100; anal cleansing materials for, 44; for communal sanitation facilities, 124; per capita effluent flow, 94; requirements for, 99, 100; self-topping, 41, 99; sewered, 94, 97, 99; tank for, 94, 99; types of, 94, 95, 96, 97, 98
Aridity indexes, 45
Ascaris lumbricoides, 13, 14; epidemiology of infection with, 147; ova in compost, 83, 87; ova in pits, 42, 82; in sewerage and sludge, 147; sullage disposal and, 126; three-stage septic tank and, 107
Asia. *See* Southeast Asia
Attitudes toward sanitation facilities. *See* Cultural attitudes toward sanitation facilities
Average incremental cost (AIC). *See* Costs, average incremental (AIC)
Bacteria: chlorination and, 113; pathogenic (in excreta), 12; survival on crops, 146; survival in soil, 145. *See also* Pathogens; *name of specific bacteria or disease*
Balantidium coli, control measures and, 19
Beef tapeworm, 13, 14, 19–20, 147, 148. *See also* Tapeworm
Beltsville (BARC) aerated pile composting systems, 134, 135, 139
Benefits received in future, value of, 30
Biochemical reaction rates, temperature and, 45
Biodegradable household waste: composting toilets and, 83, 87; night soil and, 133
Biogas, 150; from anaerobic digestion of excreta, 145; carbon-nitrogen ratio of raw materials for, 151; from dung, 151, 152*n*1; production of, 151; sludge from generators of, 145; temperature and, 45, 151; from vault toilet wastes, 52
Biological oxygen demand (BOD): sullage and, 125, 127; treatment ponds and, 128, 135, 139
BIOREACTOR system, 135
Birds and tapeworm transmission, 20
Bore-hole latrine, 80, 81
Bucket latrines, 116, 117
Bulking materials, 139, 141
Carbon-nitrogen ratio, 134, 140, 151
Carcinogenic chlorinated hydrocarbons, 113
Carp, 149
Cartage systems. *See* Vault and cartage systems
Cattle, 20; beef tapeworm and, 147. *See also* Cow dung for biogas
Children: control of stools of, 21; excreted infections and, 21; hygiene education for, 21; latrines and safety of, 64, 66; as main source of infections, 17; methemoglobinemia in, 22; schistosomiasis and, 15; toilet use by, 21
Chlorination of sewerage effluent, 113
Choice of technology, 24; algorithm for, 46, 48, 49, 50; checking the tentative, 51; critical information for, 50; economic and financial aspects of, 31, 41, 43–44; environmental factors in, 45; institutional constraints and, 45; population density and, 81; soil conditions and, 41, 42, 81; water supply service to houses and, 46; water table and, 81. *See also* Sanitation technologies
Cholera, 12, 15–16; control measures and, 19
Cistern-flush toilets: anal cleansing materials and, 44; for communal sanitation facilities, 124; low-volume, 55
Clonorchis sinensis, 12, 13, 148
Collection vehicles: importance of access for, 118; labor requirements, 120; night soil and, 118, 119
Comfort stations, 122, 124
Communal sanitation facilities, 122, 123; advantages and disadvantages of, 124; design criteria for, 122–24. *See also name of specific type of facility*
Community organization: community facilities and, 122; cost of, 32
Community participation and preferences, 44; characteristics of, 23–25; in design of latrines and toilet superstructures, 61, 64; importance of, 23, 81; sanitation program planning and, 42. *See also* Cultural attitudes and design of sanitation facilities
Community support activities, costing of, 32–35
Community workers, 25. *See also* Self-help
Complementary investments, 44
Compost, 43; aeration and oxygen supply and, 141; ashes in, 84, 87; carbon-nitrogen ratio in, 87; condensate and leachate control, 141–42; curing and storage of, 142; equipment for, 143, 144; moisture level of, 84; monitoring and management of, 142; odors and, 142; site design for, 143; systems for treatment of, 133, 134, 135, 138, 139–40; temperature in, 83, 141, 142. *See also* Composting toilets; Night soil
Composting toilets, 83–84, 85, 86, 87–88. *See also* Batch and cartage systems; Compost; DVC toilets
Control measures for excreted infections, 18
Conventional sewerage systems: advantages of sewered PF system over, 57; cistern-flush toilets and, 109; disadvantages of, 109, 110; economic costing of (example), 33–35; high costs of, 110; pipes for, 109–10; sewerage collection and, 109–13.
Cost-benefit analysis, 27
Costs, 30, 43, 82, 122; average incremental (AIC), 30, 34, 35; of sanitation services, 3. *See also* Economic costing; Financial costing
Cow dung for biogas, 151, 152*n*1
Crops, pathogens on, 146
Culex pipiens, 12, 22*n*2, 126; *quinquefasciatus*, 20; species, 22*n*2. *See also* Mosquitoes
Cultural attitudes and design of sanitation facilities, 23, 47, 51, 61, 77, 122, 124. *See also* Community participation and preferences; Personal choice
Defecation: cultural aspects, 14, 23–24, 39, 124; position for (and choice of toilet fixtures), 61; terms for, 23
Diarrhea, 11, 12. *See also name of specific*

- Diarrhea (*continued*)
diarrheal infection or of causative organism
- Digesters, winter temperatures and, 45
- Double vault composting (DVC) toilets, 39, 41, 84; costs of, 43; PF toilet as replacement for, 52; population density and, 88; VIDP latrine as replacement for, 52; water for anal cleansing and, 45
- Drainfields, 101–02, 104, 105
- Drains for sullage disposal, 126
- Ducks raised in ponds, 149
- Economic costing, 27–28; AIC and, 30; direct inputs and, 29–31; as early screening of sanitation technologies, 31; examples of, 32–35; of foreign exchange, 28–29; opportunity cost of capital and, 29; of unskilled labor, 28. *See also* Financial costing
- Education: exchange visits and, 25; preference differences and, 24; sanitation program planning and, 45; for use of DVC toilets, 87. *See also* Training of community workers
- Elephantiasis, 12, 14. *See also* Filariasis
- Emergencies, provision for, 25
- Entrobium vermiculans*, 19
- Escherichia coli*, control measures and enteropathogenic, 19
- Excreta: anaerobic digestion of, 74; chute cleaning and, 77; community attitudes and, 45; deposition in dry climates, 14; deposition in wet climates, 11, 12; flushing of, 74; helminth pathogens in, 13; insect-free, 20; pathogens in, 12; percolation of liquid fraction in soils, 74; re-use of, 44, 50, 82, 145–52; sewers not required for, 57
- Excreted infections, 15–17; children and, 21; control of, 18, 20–21; environmental classification of, 17–20. *See also* Pathogens
- Excreted load, 15–16
- Fasciolopsis buski*, 13; infestation from aquatic vegetables, 12
- Feasibility study, 26, 43. *See also* Sanitation program planning
- Fecal coliform and streptococci standards, 148
- Feces, excreted load of pathogens in, 15–16. *See also* Excreta
- Fertilizers: septic tanks and, 55; from vault toilet wastes, 52; *See also* Compost
- Filariasis: bancroftian, 12, 126; *Culex quinquefasciatus* and, 20, 22; *See also* Elephantiasis
- Filtration methods, 110, 111
- Financial costing, 27, 31–32. *See also* Economic costing
- Fish: control hazards associated with, 149; disease and, 148
- Fish ponds, 148–49
- Fixtures. *See* Latrine and toilet fixtures
- Flies: aquaprices and, 97, 100; covers on toilets to exclude, 69; ROEC's and, 77, 82; in unimproved pit latrines, 73; vent pipes and, 77; VIP latrines and, 82. *See also* Insects
- Flotation (sewerage treatment), 110
- Flush toilets, 29; costs of (with septic tanks), 43; water requirements for, 89. *See also* Cistern flush toilets; PF toilets; Toilets
- Funding: financial costing and, 31–32; by government, 32
- Giardia*, control measures and, 19. *See also* Protozoa
- Groundwater: choice of sanitation technology and level of, 42; danger of pollution of, 82; nitrate pollution of, 22; on-site excreta disposal and pollution of, 21–22; sullage disposal and contamination of, 124. *See also* Water; Water table; Well water
- Helminths: with aquatic hosts, 20; chlorination and, 113; indicator organisms, 148; pathogenic (in feces), 13; sewerage treatment and, 110–11; soil transmitted, 19; sullage disposal and, 126; on crops, 146; in soil, 145. *See also* Trematodes; *name of specific helminth or disease*
- Hepatitis, 12, 15. *See also* Pathogens; Viruses
- Hookworm, 14, 111
- Hosts, nonhuman, 17. *See also name of specific host*
- Household-based facilities, 122
- Household wastes. *See* Biodegradable household wastes
- Housing density: choice of sanitation technology and, 42–43; sullage disposal and, 126. *See also* Population density
- Humus production, DVC toilets and, 83, 88
- Hymenolepsis*, control measures for, 19
- Ibadan comfort stations, 122, 124
- Infections: disease and, 15; latency and, 16; reservoirs of, 12, 15. *See also* Excreted infections; Pathogens; *name of specific infection or causative agent*
- In-house connections, 39, 42
- Insects: poultry in control of, 116; transmission of pathogens by, 15, 20. *See also name of specific insect*
- Institution-community linkage, 25. *See also* Community participation and preferences
- International Drinking Water Supply and Sanitation Decade, 3, 4, 7
- Kinship group-based facilities, 122
- Labor (self-help), 44
- Latency, 15, 16
- Latrine programs, reasons for failure of, 20–21
- Latrines: anal cleansing materials and mechanical seals for, 44; distance from wells of, 22; land areas required for sewerage, 45; nature of soil and, 22; requiring no water, 39; in schools, 21. *See also* Toilets; *name of specific kind of latrine*
- Latrine and toilet fixtures, 65, 66, 67, 68, 69, 70, 71; for composting toilets, 69, 72; for PF toilets, 69, 72; for ROEC's, 66, 69; for vault toilets, 69, 72; for VIP latrines, 64, 66, 69
- Latrine and toilet superstructures, 61, 62, 63
- Laundry facilities, 45, 124
- Least-cost choice, 27, 44
- Lending agencies, general policy of international, 31
- Lighting for latrines and toilets, 61
- Liver flukes, 148. *See also Clonorchis sinensis*
- Loans from banks (securing), 32
- Maintenance: attendants and, 124; of community facilities, 124; of drains, 127; expenses of, 45, 100; of water seal, 39, 94
- Mara, D. Duncan, 116
- Mariculture, 148
- Maturation lagoons, 113, 145
- Methane, 52, 151. *See also* Biogas
- Methemoglobinemia in children, nitrate levels in drinking water and, 22
- Mosquitoes: breeding inhibitors for, 81; disposal pits and breeding of, 42; in ROEC's, 82; septic tank overflow and, 105; sullage disposal and, 126; in VIP latrines, 82. *See also Culex*
- Multrum, 83, 84
- Municipal revenues, 31
- Night soil, 116, 119; carbon-nitrogen ratio of, 151; defined, 133; ponds for treatment of, 133; thermophilic composting and, 133, 135; treatment works for, 118; *See also* Compost; Resource recovery
- Nitrate pollution of groundwater, 22, 126
- North Africa, example of sanitary conditions in, 13–15
- Odors, 69, 73, 97, 100; compost and, 142–43; septic tank effluent and, 104; vent pipes to control, 77
- Off-site treatment of wastes, 129, 130, 131, 132; aerated pile for, 140, calculations for, 134, 136; night-soil treatment ponds for, 133–37, 140; objectives of, 128; thermophilic composting for, 133–34; waste stabilization ponds for, 128, 135
- Opistorchis*, 148
- Oxfam disaster sanitation unit, 123
- Oxidation ditches, 111
- Pacu (fish) in aquaculture, 150
- Pastures, sewerage irrigated, 147
- Pathogens: aerated lagoons and, 111; chlorination and, 113; in compost, 83, 87, 135, 147; control of intrafamilial transmission of, 21; destruction of, 112, 133; excreted load of, 15–16; in fish ponds, 148; host response to, 17; infective dose of, 16–17; land application of effluents and, 111, 113; lethal factors for, 146; maturation lagoons and, 145; multiplication after excretion, 16; oxidation ditches and, 111; sand filtration methods and, 111; in septic tank effluents, 101, 107; in sewerage effluents

- (standards for), 147; in sludges and composts (standards for), 147; sullage and, 126; survival in environments, 16, 145, 146; temperature and time in destruction of, 112; time required for destruction of (in pits), 42, 43, 82; waste stabilization ponds and, 148; in waste-treatment ponds, 139
- Pedestal seats, 67, 71; "Colombian," 89; preventing children from falling through, 66. *See also* Latrine and toilet fixtures
- Personal choice, 52, 61. *See also* Community participation and preferences
- Pigs, 20
- Pinworm, 19
- Pit latrines, 74; basic components of, 73; costs of, 43; disadvantages of unimproved, 73; double pits for, 73, 76; improved, 73, 75; as initial improvement, 55
- Pits, 75, 80; alternating, 43, 57n1; anal cleansing material in, 74, 77; design of, 77–78; double, 74, 76; high water table and, 74; infiltration capacity of, 55; life of, 42, 43, 74; offset, 77, 89; pathogens in, 82; seepage in, 126; soil conditions and, 42; for specific types of latrines, 55, 73, 76, 77, 89
- Planning. *See* Sanitation program planning
- Plumbing fixtures. *See* Latrine and toilet fixtures
- Ponds for waste treatment: aerobic, 128; anaerobic, 135, 137; anaerobic pretreatment, 128, 133; design of, 136; facultative, 128, 133, 136, 137, 150; fish grown in maturation in, 150; land requirements for, 133; maintenance of, 133; maturation of, 136, 137, 139–45; night-soil treatment and, 133, 137, 139; sullage and, 127; waste stabilization and, 128, 133, 135; winter temperatures and, 45
- Population density: choice of sanitation technology and, 42–43, 81; DVC toilets and, 88. *See also* Housing density
- Pork tapeworm, 13, 14, 19–20
- Poultry to control insects, 116
- Pour-flush (PF) toilets, 39, 41, 55; anal cleansing materials and, 44, 99; for communal sanitation facilities, 124; compared with aquaprivies, 97, 99; conversion of ROEC's to, 55; costs of, 43, 93; design of, 89, 90, 91; for flat areas, 93n1; maintenance of, 91; septic tanks and labor requirements for, 89; septic tanks for, 93; sewerage, 41, 55, 91, 92, 93; suitability of, 91, 93n1; sullage and, 55, 89, 91, 93; as vault toilets, 118; water requirements for, 89
- Precipitation (weather), choice of sanitation technology and level of, 45
- Privacy and design of latrines and toilets, 61, 123, 124. *See also* Cultural attitudes and design of sanitation facilities
- Protozoa: pathogenic (in excreta), 12; sewerage treatment and, 110–11, 113; survival time on crops, 146; survival time in soil, 145. *See also* Pathogens; *name of specific protozoa and disease*
- Public facilities. *See* Communal sanitation facilities
- Reed odorless earth closets (ROEC's), 39, 41, 55, 78, 79; advantages and disadvantages of, 77, 82; compared to aquaprivies, 97; costs of, 43, 82; lifetime of, 43; requirements for, 81; maintenance of, 81; offset pits for, 77; population density and, 81. *See also* VIDP latrines; VIP latrines
- Resource recovery: agricultural, 145–48; aquacultural, 148–50; biogas and, 145, 150, 151; social, institutional, and economic aspects of, 151, 152
- Roundworm, 13, 14. *See also* *Ascaris lumbricoides*
- Salmonella*: control measures and, 19; in raw sewerage in England, 16
- Sand filtration methods, 110, 111
- Sanitation: in high-rainfall areas, 11; proportion of cash income devoted to, 43; Southeast Asian family example, 11, 12
- Sanitation facilities: based on kinship group, 122; communal, 122–24; low-cost, 4, 124; most common, 73; operation and maintenance of, 25; primary constraints on, 4; unsatisfactory operation due to lack of maintenance of, 45; upgrading sequences for, 52–57. *See also* Cultural attitudes toward sanitation facilities; *name of specific kind of facility*
- Sanitation improvements: alternative sequences for, 56; of community facilities, 124; costs of sample sequences for, 56; economic costs of, 56; incremental, 4–5, 7, 45, 52; priority for, 55; staged, 55–57; of VIP and VIDP latrines and ROEC's, 82
- Sanitation program planning, 5, 7, 81; community participation in, 23–26, 42, 44; data collection for, 5; education and institutional development programs and, 45
- Sanitation services, cost of, 3
- Sanitation technologies: alternative, 4, 40; complementary investments in, 44; comparing, 39, 44–45; deriving costs for different, 30; description of, 41; economic costing for early screening of, 31; household financial contribution and choice of, 44; housing density and choice of, 42–43; land-use and, 45; nonsewered options, 7; rural-urban suitabilities of, 41; selections of, 24; training and, 25; variety of, 39, 40, 41; water requirements of, 41. *See also* Appropriate technology; Selection of sanitation technology; Technology; *name of specific technology*
- Schistosoma* species, 20; aerated lagoons and, 111
- Schistosomiasis, 12, 13, 14; transmission of (by children), 15; urine as fertilizer and, 84
- Screening (sewerage treatment), 110
- Sedimentation (sewerage treatment), 110
- Seepage pits for sullage, 126. *See also* Pits
- Self-help, 32, 44, 87
- Septic tanks, 41, 43, 101, 104–08; biochemical oxygen demand and, 93; designs for, 103; effluent disposal from, 101–02, 104; for PF toilets, 89, 92, 93; sludge and, 56, 94, 101; slurry and, 52, 55; soil pollution and, 101, 107; sullage and, 52, 105; three-compartment, 41, 52; two-compartment, 55, 101, 102
- Sewerage, 109–11, 113; costs and, 3, 4, 43, 57; disposal and soil conditions, 42; resource recovery and use, 111–13, 145–52; sullage and, 57; tertiary treatment of, 110, 111. *See also* Conventional sewerage system; Small-bore sewers
- Sewerage systems: cost of additional water for, 28; pathogenic effluents and, 110; per capita average incremental cost of, 30; for PF toilets, 91, 92, 93; sullage and, 30, 55, 57, 90, 109, 126; volumetric calculation of costs for, 30. *See also* Conventional sewerage systems; Sewerage; Sludge; Small-bore sewers
- Sewered aquaprivies. *See* Pour-flush (PF) toilets
- Sewered pour-flush toilets. *See* Pour-flush (PF) toilets
- Sewers: small bore, 56, 93, 99, 107, 114–15; for sullage, 55, 57, 90, 93, 109, 126. *See also* Sewerage systems; Storm water
- Shadow pricing. *See* Economic costing
- Shigellosis, control measures and, 19
- Shower facilities, 45, 124
- Sludge: activated effluent, 110; biogas from, 145, 151; collection of, 56; pathogens in, 110–11, 113; quality of, 110; rate of accumulation of, 101; removal of, 94, 101; treatment and disposal of, 110–13
- Slurry: as fertilizer, 55; septic tanks and, 52, 55
- Snails, 16, 148
- Soakaways, 101–02, 104, 105
- Soil pollution, 42; children and, 21; from septic tanks, 101, 107
- Soils, 45; latrine-to-well distance and nature of, 22; low absorptive capacity and sewerage PF systems, 9; percolation tests of, 102, 104; sanitation technology and nature of, 42; survival time of pathogens in, 145
- Southeast Asia, sanitary conditions in (example), 11–12
- Spray irrigation hazards, 147
- Squatting plates, 68, 69, 70, 71; community preferences and, 64; composting toilets and, 84, 87; placement of (VIP latrines), 72; preventing children from falling through, 64; preventing soiling of, 64; replacement by waterseal unit, 55. *See also* Latrine and toilet fixtures
- Storm water, 30, 127
- Subsidies, 44
- Sullage, 125–27; aquaprivies and, 97, 99; costs of sanitary technology and, 30, 57; disposal of large volumes of, 56; PF toilets and disposal of, 89, 91; ROEC's and disposal of, 82; sewers and drains for, 55, 57, 90, 93, 109, 126; stormwater and, 30; three-stage septic tank and, 52; two-

- Sullage (*continued*)
 stage septic tank and, 55; VIP and VIDP latrines and disposal of, 82; vault and cartage systems and, 120, 121
- Swine. *See* Pigs
- Taboos. *See* Cultural attitudes and design of sanitation facilities
- Taenia: saginata*, 13, 14, 19–20, 147, 148; *solium*, 13, 14, 19–20
- Tankers. *See* Vacuum tankers
- Tank trucks, 118
- Tapeworm, 13, 14, 147; transmission by birds, 20. *See also* Beef tapeworm; Pork tapeworm
- Technology: loans and affordable, 32; options for not-affordable, 32; real resource cost of, 29. *See also* Appropriate technology; Choice of technology; Sanitation technologies; *name of specific technology*
- Temperature: for methane production, 45, 151; sanitation technology choice and, 45
- Three-stage septic tanks. 41, 52, 55
- Tilapia, 149
- Toilet fixtures. *See* Latrine and toilet fixtures
- Toilets, 39; community preferences and, 50–51; inside, 42, 61; requiring no water, 39; water consumption and flush, 29; water tap location and, 39, 41, 42. *See also* Latrines; *name of specific kind of toilet*
- Toilet superstructures. *See* Latrine and toilet superstructures
- Training of community workers, 23. *See also* Education
- Transmission of excreted infections, 19
- Trematodes and snails, 16
- Trichuris*, 148
- Typhoid, 12, 15; control measures and, 19
- United Nations Water Conference (1977), 3
- Upgrading. *See* Sanitation improvements
- Urinals, 123
- Urine: in composting toilets, 83–84; drainage channel for, 69, 84; *Schistosoma haematobium* and disposal of, 20, 83
- User charges, 31
- User participation. *See* Community participation and preferences
- Vacuum tankers, 118, 120
- Vacuum truck, 118
- VAM system, 135
- Vault and cartage systems, 118–21. *See also* Composting toilets; PF toilets
- Vault latrines and groundwater, 22
- Vault toilets, 39, 41, 43, 52, 54, 55, 118, 119; to replace bucket latrines, 116; *See also* Composting toilets; DVC toilets; PF toilets
- Ventilated improved double-pit (VIDP) latrines, 39, 76; advantages and disadvantages of, 82; costs of, 82; pit design for, 77; population density and, 81. *See also* ROEC's; VIP latrines
- Ventilated improved pit (VIP) latrines, 41, 55, 56, 73–74, 75, 77; advantages and disadvantages of, 82; compared to aquaprivy, 94, 97; cost of, 56, 82; economic costing of (examples), 32–33; lifetime of, 43; maintenance of, 73, 81; population density and, 81. *See also* ROEC's; VIDP latrines
- Ventilation for latrines and toilets, 61, 69, 73, 75
- Vent pipes, 73, 75, 77
- Viruses: control measures and, 19; pathogenic in excreta, 12; sewage treatment and, 110–11, 113; survival time on crops, 146; survival time in soil, 145. *See also name of specific virus or disease*
- Waste: biodegradable, 83, 87, 133; reuse of, 82, 133. *See also* Compost; Night soil; Sewerage
- Waste stabilization ponds for elimination of pathogens, 148. *See also* Ponds for waste treatment
- Waste treatment ponds. *See* Ponds for waste treatment
- Water: cost of, 28, 29; domestic, 7; hand-carried supplies of, 39, 42; hot, 124; patterns of use, 7; reducing nonessential use of, 57; toilets and, 39, 41, 124; volume of use of (sullage and), 125, 126; taps and connections for, 42. *See also* Well water
- Waterborne sewerage, 4
- Water consumption: achieving savings in, 7; choice of sanitation technology and, 39, 41; reduction of, 57; volume of (and sullage), 126
- Water-saving plumbing fixtures, 7, 124
- Water seals: anal cleansing materials and, 44; aquaprivies and, 94, 97; maintenance difficulties with, 39; manufacture of, 89; PF toilets and, 82, 89, 97
- Water storage vessel in house for PF toilets, 55
- Water supply sewerage levels, 39, 42; incremental improvements in, 52
- Water table: high, 74, 87; selection of technology and, 42, 81. *See also* Ground water
- Water taps, 39, 42
- Well water, soils and contamination of, 22
- Whipworm, 13, 14
- Windrows, 135
- Yard taps, 39, 42
- Yersinia*, control measures and, 19

The full range of World Bank publications, both free and for sale, is described in the *Catalog of World Bank Publications*; the continuing research program is outlined in *World Bank Research Program: Abstracts of Current Studies*. Both booklets are updated annually; the most recent edition of each is available without charge from the Publications Unit, World Bank, 1818 H Street, N.W., Washington, D.C. 20433, U.S.A.

John M. Kalbermatten is senior adviser for water and wastes and Charles G. Gunnerson is senior project officer in the Transportation and Water Department of the World Bank. DeAnne S. Julius is acting economic adviser for the Energy Department of the World Bank. D. Duncan Mara is professor of civil engineering at the University of Leeds, England.



A World Bank Publication

The United Nations has designated the 1980s as the International Drinking Water Supply and Sanitation Decade. Its goal is to provide two of the most fundamental human needs—safe water and sanitary disposal of human wastes—to all people.

To help usher in this important period of international research and cooperation, the World Bank is publishing two volumes on appropriate technology for water supply and waste disposal systems in developing countries. Since 1976, Bank staff and researchers from various countries have been analyzing the economic, environmental, health, and sociological effects of various technologies to identify the most appropriate systems for the needs and resources of different areas. The research has included field investigations in nineteen countries.

Since the technology for supplying water is better understood, the emphasis in these volumes is on sanitation and waste reclamation technologies, their contributions to better health, and how they are affected by water service levels and the ability and willingness of communities to pay for the systems.

This manual presents the latest field results of the research, summarizes selected portions of other publications on sanitation program planning, and describes the engineering details of alternative sanitation technologies and how they can be upgraded. The guidelines, procedures, and technologies are based on the World Bank's own research in nineteen countries. The twenty-two chapters are divided into three parts: socioeconomic aspects of sanitation program planning, sanitation program planning, and sanitation technology options. The manual is extensively illustrated with technical diagrams of the recommended sanitation systems and their components.

The material is intended both for professionally trained project engineers and scientists and for technicians and field workers who are familiar with the particular geographic and cultural conditions in their project areas.

The Johns Hopkins University Press

Baltimore and London

ISBN 0-8018-2584-9