



# More than just technical skills required

By Tim Hayward

**Most engineers working in the field during an emergency situation are without doubt technical experts. Yet it is becoming increasingly evident that such sensitive situations require more than simply expert engineering. Relief training is in need of a change in focus to prepare those working in the field for the cultural diversity and social hazards that await them.**

**T**he effective execution of water and sanitation projects in disaster relief programmes requires, amongst other things, the right people to be in place at the right time. Two key elements of the strategy for achieving this are the selection of people with the right level of skills and experience, and appropriate training that will enable them to adapt to the particular demands of relief work.

## The work of the expatriate water and sanitation engineer

Much of the work that expatriate engineers will find themselves involved in while on relief assignments, although requiring a great deal of ingenuity to bring about appropriate solutions, is actually not technically demanding. To construct water storage tanks and a piped distribution system in a refugee camp, from standard pre-packaged kits, although requiring some experience and specific knowledge, and a practical aptitude to do it well, does not require a high level of technical competence. What is generally more demanding however, is the environment within which they will find themselves working. This is one across cultures; under the severe pressure of a dynamic and rapidly evolving situation, such as in Albania and Macedonia in 1999; against tight deadlines; and whilst having to face possible threats to security, particularly in conflict areas; and a host of moral and ethical dilemmas. A prime example of the latter being the Rwandan refugee camps during 1994. Similar comments can be made about the construction of a number of emergency pit latrines, which is more likely to be limited by logistics capacity than technical competence. Furthermore, and perhaps more importantly, a successful

emergency sanitation programme is much more than a series of holes in the ground. It will only succeed where culturally appropriate solutions are accompanied by a great deal of community participation and commitment.

## The requirement for training

In order to prepare for assignments in emergency relief, people will need to consider far more than just their engineering or construction background. They should consider training that will introduce them to the relief environment, raise their awareness and appreciation of cross-cultural issues, prepare them for the requirements of working under difficult security situations, and prompt them to give some thought to the moral and ethical dilemmas that are such a feature of complex emergencies in particular.

The above should not detract from the fact that specific technical training may well be required, even for someone who has already achieved a high level of technical competence as a professional engineer. Their requirement for training may focus on enabling them to adapt their existing skills, as well as introducing them to the standards and codes that are applicable to this sector, such as, the Sphere Standards<sup>1</sup>, and the Red Cross and NGO (non-Governmental Organizations) Code of Conduct<sup>2</sup>. Technical training should also introduce them to the argument for the most immediate acceptable solution, as opposed to the best engineering solution. The pressures of time and the overriding humanitarian imperative, particularly during the early phases of an emergency, often mean that the best engineering solution to a technical requirement will have to wait, while a quick fix that

1. The Humanitarian Charter and Minimum Standards in Disaster Response.

2. Principles of Conduct for the International Red Cross and Red Crescent Movements and NGOs in Disaster Response Programmes.

# Water and sanitation in emergencies



Tim Hayward

RedR  
training course - Water  
Supply Treatment and  
Distribution

**'there is a concern over how often inexperienced engineers are pushed beyond their level of competence by field managers who don't fully appreciate the complexity of what they are trying to achieve.'**

meets the basic needs of the moment takes precedence. Valuable, and even life saving, time can be lost if this is not fully appreciated.

Despite the comments above, on the level of technical expertise required, there is a concern over how often inexperienced engineers are pushed beyond their level of competence by field managers who don't fully appreciate the complexity of what they are trying to achieve. As unacceptable as this is it must be recognized that there is a culture within relief work that requires people to be flexible, adaptable, able to take on unexpected roles, and to push their own limits. Inappropriately delivered training may actually only serve to compound this problem. A small amount of knowledge gained on a short training course may give false confidence to the inexperienced, and tempt them to over extend themselves – particularly where someone has attended a short course on a subject which is peripheral to their core competence. The difference between, on the one hand, a little knowledge being a dangerous thing, and on the other an awareness of related issues enabling one to do one's own job better, must be clearly understood. A group that is particularly vulnerable to this are those that carry the very broad title of 'logistician'. In many relief organizations the logisticians can easily find themselves drawn into dealing with a very wide range of technical issues.

The comment above on field managers

also highlights the training need for those who manage, and others who are associated with water and sanitation programmes, to have at least some minimum level of understanding and familiarity for what is involved.

## The provision of training

A relatively recent and encouraging development is that a number of British universities now include modules on emergency water

supply, sanitation, or environmental health engineering, in their engineering first degree courses. Similarly there are a growing number of masters degrees now available which specialize in rural water supplies, environmental health, and other subjects of direct relevance to water and sanitation in disaster relief. Some relief organizations, both in Europe and North America, provide their own in-house short course training, and RedR has a well established programme in the UK of short course training (details can be found on the RedR web site at: [www.redr.org](http://www.redr.org)). The notable gap is in field-based short course training, of which there is currently very little available. In the near future it is the intention that the RedR programme will be expanding into this area. The advantages of providing training much closer to where this type of work is actually being conducted are many and various.

The principal advantage is that training can be brought to national staff and not just internationals. Very few relief organizations have sent national staff to RedR training courses in the UK. The training of nationals will ultimately do a great deal for that seemingly elusive goal in emergencies of developing local capacity.

Training can be context specific, and can be tuned in to the particular requirements of people working in that location. This is in contrast to the necessarily broad and general nature of training that is carried out at distance from the field.

# Water and sanitation in emergencies

Training can then be made available to those (internationals) who spend most of their time in the field, rather than them having to fit it in whilst on leave in Europe or between assignments, which is currently the case for many.

Field based training can do a lot for improving co-ordination, information sharing, and general networking between individuals and organizations who all happen to be working in the same region.

Relief organizations that do actually pay more attention to the training requirements and career development of their field staff will be more keen to send them to local events than to fly them half way across the world.

An issue which arises out of this last point, is the assumption that budget lines are available to cover the costs of training for field staff. Unfortunately at present this is often not the case, and requires the attention of both the relief organizations themselves and their funders.

Training for water and sanitation engineers in disaster relief clearly needs to address a lot more than just their technical requirements. Training needs to:

- Help them to adapt their existing skills
- Prepare them for the relief environment
- Ensure that they have the right level of technical competence as well as recognizing their own limits
- Give the individual sufficient awareness of issues peripheral to their own area of competence to allow them to plan and to implement appropriately
- Be available to all who need the training, both international and national staff, and wherever they need it

## about the author

Tim Hayward is a

RedR Training Manager.

Prior to joining RedR Tim worked on a number of relief assignments as a Water Engineer, Technical

Team Leader, Water &

Sanitation Coordinator for Oxfam, MSF, and UNHCR.

Tim can be contacted at:

training@redr.demon.co.uk.

## References

Davis, J. and Lambert, R. (1995)

Engineering in Emergencies: a practical guide for relief workers, ITDG Publishing, London.

For further information about RedR and its short-course training programme worldwide visit the web-site at:

[www.redr.org](http://www.redr.org) or contact: RedR, 1 Great George Street, London SW1P 3AA, UK. Tel: + 44 070 233 3116; Fax: + 44 070 222 0564 or email:

training@redr.demon.co.uk

## THE LIFE SUPPORT SYSTEM

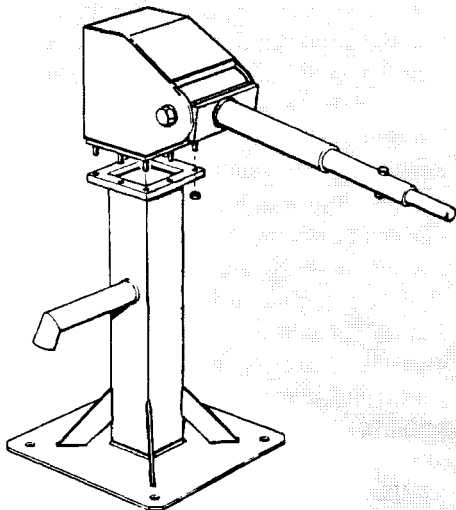

With over 40 years of well drilling know-how, VRM has developed a range of simple-to-use pumping equipment suitable for the complete spectrum of environments. From the dewatering of hand-dug wells to tapping a water source at a depth of 100 metres, VRM can supply complete light-weight hand drilling equipment and handpumps, together with PVC screens and casings. Pump equipment includes the SWN 80 which can be modified to act as either a pressure or suction pump operating to a depth of 40 metres. And, the SWN 90 pump capable of raising water from a depth of 100 metres.



**Van Reekum Materials bv**

P.O. Box 98, 7300 AB Apeldoorn, Holland.

Telephone: +31 55 533 54 66, Fax: +31 55 533 54 88

e-mail: [info@reekum.nl](mailto:info@reekum.nl), Internet: [www.reekum.nl](http://www.reekum.nl)

**VRM GETS THE MOST OUT OF THINGS**