

8 2 4

A A F 7 5

# ACTION PEACE CORPS



LIBRARY

International Reference Centre  
of Community Water Supply

## PROGRAM & TRAINING JOURNAL

*SPECIAL ISSUE*

# WELLS MANUAL

FIGURE 1  
FRONT VIEW

Removeable Casted Head  
Chapeau Moule Demontable

Casted Body  
Corps Moule

2 1/2" Reducer  
Reducteur 50/60-40/49

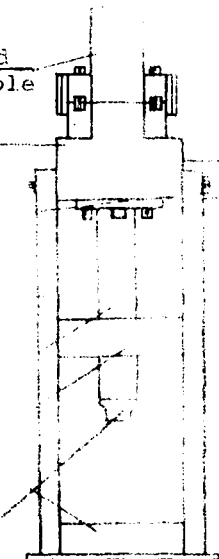

FRONT VIEW  
FACE OF HEAD

FIGURE 2  
SIDE VIEW

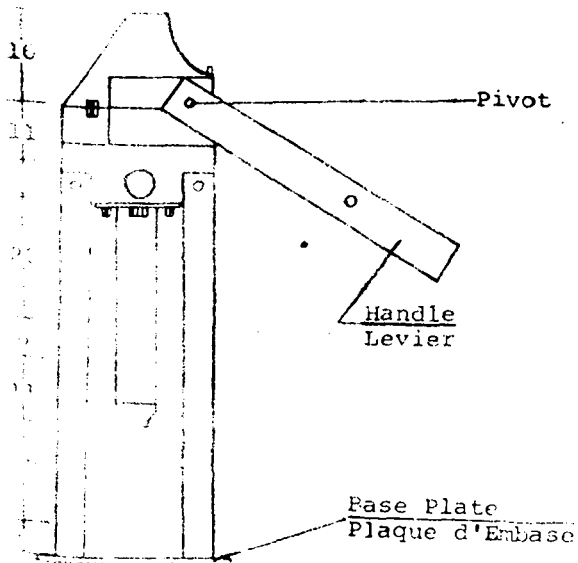

SIDE VIEW  
FACE OF BODY

824-AAF75-  
1181

# TABLE OF CONTENTS

| <u>PART</u> | <u>ARTICLE</u>   | <u>PAGE</u> |
|-------------|--|-------------|
| I           | EDITOR'S NOTE, INTRODUCTION.....   | 1           |
| II          | WELLS CONFERENCE REPORT.,.....   | 5           |
| III         | GROUNDWATER WELLS/TECHNICAL REALITIES, C. Mary.....                                  | 15          |
| IV          | SAMPLE PROPOSALS--CONTRACTS.....   | 47          |
|             | 1. Proposal Upper Volta.....   | 49          |
|             | 2. Contract Togo.....  | 55          |
| V           | LARGE DIAMETER WELLS.....  | 59          |
|             | 1. Togo, Cementing with a Mold, D. Rowley....  | 61          |
|             | 2. Togo, Dig a Meter-Pour a Meter, J. Tonery.  | 73          |
|             | 3. Niger, A Well Dug Well, S. Isom.....  | 77          |
|             | 4. U. Volta, Well Digger's Manual, Matthews.   | 106         |
|             | 5. Senegal, Cementing Without a Mold, PCVs..   | 127         |
|             | 6. Senegal, Hand Dug Plastered Well, McGurn.   | 149         |
| VI          | SMALL BORE WELLS.....  | 155         |
|             | 1. Chad, Small Bore Tubewells, Lanternier,<br>G. Greenwood, M. Dower.....            | 157         |
|             | 2. Togo, Small Bore Drilling, J. DeMoachel..   | 196         |
|             | 3. Togo, Cost Estimates Per Meter Small<br>Bore Wells, PCVs Togo.....                | 212         |
| VII         | SPECIAL SUBJECTS.....  | 217         |
|             | 1. Niger, Report on the Installation of an<br>ABI Pump, S. Simmons.....              | 219         |
|             | 2. Niger, Small Bore Wells for School<br>Gardens Maradi, L. Yellott.....             | 224         |
|             | 3. Development of <u>Hand Operated Water Pump</u> ,<br>R.D. Fannon, B. Columbus..... | 227         |
|             | 4. Uses of Dynamite in Large Bore Wells<br>Togo, C. Henney.....                      | 241         |

1  
A  
,

1

1

# **PART I**





EDITOR'S NOTE

Vince Abramo, Public Works Specialist for the Africa Region of Peace Corps, compiled this second Peace Corps Wells Manual after the Wells Conference held in West Africa in the Summer of 1974. The Manual reflects a wide variety of techniques and approaches being used by Volunteers presently in wells projects.

In publishing this Special Issue, the Peace Corps Program and Training Journal, in conjunction with the Africa Region, hopes to provide both staff and Volunteers with recent, pertinent information produced in the field. Additional copies of the Manual are available on request from either the Journal or the Africa Region.

On behalf of the Peace Corps staff, I would like to express gratitude to the many Volunteers and staff who worked above and beyond the call of duty to provide these articles, illustrations, and photographs.

Linda Muller  
Assistant Editor

Francis A. Luzzatto  
Editor

Program and Training Journal Publication  
January, 1975      Peace Corps, Washington D.C.

# INTRODUCTION

This manual is to provide information on a wide range of well construction techniques. Hopefully, the user will not see each method of construction separately, but rather be able to synthesize techniques to fit the particular situation. If taken in this light, this manual offers a number of technical and methodological combinations, making it possible to select the most efficient well method. Volunteers and others who have contributed to this manual do not regard their methods as final, but rather welcome changes and suggestions. I hope that reading and understanding this manual will stimulate new innovative ideas.

The manual is in several sections which cover various techniques used. Other sections include miscellaneous pieces on well pump studies and specific well projects. There is also a short piece on the use of dynamite. In addition, a bibliography section dealing with sources of information has been included.

Trying to include everything would certainly cause us to drift from the main objectives of the manual. Suffice to say that what we have done is a second attempt at giving Peace Corps Volunteers a place to start. Hopefully, they will continue to up-date and improve this publication.



Vincent J. Abramo  
Public Works Specialist  
Africa Region  
Peace Corps/Washington  
1974



**PART II**

**WELLS CONFERENCE REPORT**

1

1

## WELLS CONFERENCE REPORT

ATAKAPAME, TOGO - JULY 15-20, 1974

The conference was held away from Lome in Atakapame so as to be near on going well activity and away from city disturbances.

As it turned out, the schedule was followed fairly closely. Almost all participants and delegates were Peace Corps Volunteers. There were a few staff and two outside water experts also present. The conference itself was intended to be a working technical meeting among Peace Corps Wells Volunteers in West Africa. For various reasons host country nationals, members of international assistance groups, etc., were not invited. Prudence dictated that the conference be limited due to size, cost, language, etc.

The makeup of the conference was indeed the best in order to accomplish our original objectives - to facilitate an exchange of technical information and discussions, concerning common problems between wells Volunteers in West Africa.

Niger's approach seemed to be best organized, well integrated into the governmental structure, and tuned to the needs and priorities of the host country. Rather than going into technical methodology presented at the conference, it is included in this manual.

Peace Corps Upper Volta has had tremendous results in numbers of successful wells. Their methods are also included in the manual.

The problems of potability in large bore wells were discussed in detail. The discussion included solutions and approaches to sanitizing. Those mentioned were to install a pump and place a cap or cover over the top of the well. Before installation, the well can be purified best by chemical means. A second method would simply entail an annual cleansing of the well, either by villagers or government teams. Should cleaning of the well be done by government teams, rehabilitation and

redeepening activities could be done simultaneously. Some difficulties were posed in terms of availability of parts to repair pumps and replace casings or screens. Niger was concerned with the problem of maintenance and repair of small bore wells.

The discussion drifted back to a discussion of large bore wells, self help wells in particular. Al Miller APCD/Niger discussed some of the problems concerning wells used by nomads. Niger has a large percentage of nomadic peoples, and Miller pointed out that only about half the available nomads helped at well sites. PCV's, he said, had insisted that all nomads work at the site. The question was raised whether or not subtle coercion could be used in self help projects. Miller made the comment that because wells in Niger must be dug to great depths, it was often difficult to get villagers to dig behind 50 meters. The topic of motivation and coercion could have been discussed further but would have hardly resulted in any conclusions.

#### Host Government and Other Agency Wells Contributions:

PCV Pete McDonald of Togo spoke of wells construction in the Animation Rural Program. The Service d'Assainissement is supposed to provide cement, steel rod, transport, and masons. The result has been that the U.S. Embassy, which initially provided some funding, is now more and more involved in the project. There is a need to become less dependent on the Embassy and more dependent on Service d'Assainissement as the supporting agency. McDonald did mention the need to find funding for projects outside of the government. For one to depend on host government agencies to implement programs is problematic at times, since government infrastructures are not all that capable to deal with the volume of work.

Chad's spokesman, PCV Dean Lanternier, discussed the history of Chad's Well Program. USAID will support the well program in Chad this year.

Senegal's representatives, PCV Bob McGurn and PCV Thomas Gilroy, discussed the Rural Animation Program in Senegal. Most wells are currently funded by Self Help monies coming from the people themselves. Wells are geared more to providing essential water

needed for irrigation of crops as well as human needs.

Upper Volta's Phil Coolidge discussed Peace Corps' work with the Service Hydrologue. In the past, he explained, materials and transport costs were covered by self help funds from the Embassy, OXFAM, or the U.S. Freedom from Hunger Foundation. Presently, however, USAID is funding most of the program. Money does not seem to be a problem. The total integration of the program with the service is not yet a reality, but Coolidge said that the program is running well due to the fact that it is independent of government agencies.

Both Cameroon and Dahomey had little to contribute since both countries are just beginning to put their well programs back into shape.

Bill Tilton, Regional Training Officer based in Dakar, digressed for the time being to pose some suggestions concerning future training programs. Bill discussed the integration of the three components of training which are the language, the cross cultural, and the technical. He discussed the problems of all three when an attempt is made to coordinate the different areas. The importance of in-service training was also discussed.

The delegates raised the question of how one finds the right people to do training as well as mid-service conferences. Many delegates there knew of at least one former PCV leader or fourth year Volunteer who could contribute significantly. Names and addresses were solicited. Sources of information, through books and periodicals, are badly needed. Volunteers must have at their disposal these sources of information in order to increase the potential for success.

A day was spent on a field trip to Babu (110 km west of Atakapame). The group visited various well installations and current well drilling sites. As the whole day was spent doing site visits, there was much that each delegate learned. Other Togo Volunteers not part of the conference became part of the day's activities as they were in charge of the various well sites that we visited.

The techniques used in Togo are covered in the 1970 Peace Corps Wells Manual.



## GEOLOGY:

The first part of the day was devoted to geology and water resources, discussed by Mr. Stan Remington from USAID. Stan discussed types of geological formations as well as the presence of water and recharge capability. He suggested that PCV's begin to keep well logs so that they have more accurate records of activities and data at each well site. He also recommended saving drill samples to know where to place well screens.

Formula to determine recharge: ( R - E - S = R )  
Rainfall minus evaporation minus surface run off equals recharge.

Steve Simons of Niger discussed the positive aspects of the famous ABI hand pump. The top is strong and sturdy, he said, but several factors with the bottom linkage need to be worked out; for example, the plastic screen is too coarse. The ABI pump is sturdy but expensive. Steve suggests buying the head only and buying the rest more cheaply someplace else. Steve's report is included in this manual.

TOGO: In general PC/Togo is installing different kinds of pumps, the most frequent being the UNICEF, the Bodin, and the Japy. Specific data and comments are included in the Togo section of the Wells Manual.

WINDMILLS: Lee Yellott, PC/Niger, headed the discussion by mentioning some very basic things when one considers windmills. One should figure out how high one wants the windmill to pump to be effective. Windmills require constant attendance, particularly the Dempster, but it can pump a substantial amount of water into a reservoir.

EARTH DAM CONSTRUCTION: Although the conference was ostensibly set up to deal with small and large bore wells, there was a great deal of interest in the collection of surface runoff. Most of the conversations during the sessions dealt with earth dam construction projects either underway, as in the case of Upper Volta, or planned, as in the case of Mauritania.

During these discussions, practical concerns were discussed such as the incidence of mosquito infestation as well as mud and silt problems. Cisterns and irrigation schemes were also

discussed briefly.

Volunteers seemed to be eager for other kinds of information concerning transfers to other projects, new ideas, and sources of information. On the whole, those present found the conference to be extremely advantageous. For many, the most advantageous aspects ranged from liking the informal exchanges of information to discussions on general Peace Corps programs in the Sahel. Some thought the conference to be well planned and informative. Many felt a renewed sense of purpose as a Peace Corps Volunteer and water developer.

On the other hand, there were those things which the conferees felt were least advantageous. For example, too much time was spent on small bore wells, and too much time was spent discussing Togo. Other concerns voiced were that there wasn't enough free time, and that some of the information was simply a reiteration of what was already known. This feedback was gathered from questionnaires distributed at the close of the conference. Twenty out of thirty were completed in great detail. Many of the comments dealt with how the next conference could be better.

Recommendations:

1. Hold the next wells conference in Niamey in July, 1975 (almost unanimous);
2. Bring in more water experts from either USAID or other technical agencies;
3. Have more materials to pass out;
4. Let conferees spend more time at a work site;
5. Require that delegates be more prepared in terms of making presentations;
6. Present more detail and actual work with dynamite;
7. Also present more information on surface collection of water;
8. Submit written objectives before the conference;
9. Hold conference every two years;
10. Cover aspects of future programs;
11. Make available more photos, slides, films (Delegates did not bring much in the way of audio-visual presentations).

PEACE CORPS WEST AFRICA WELLS CONFERENCE II

July 15-20, 1974

Atakpame, Togo

COUNTRIES TO BE REPRESENTED: Cameroon, Chad, Dahomey, Liberia,  
Niger, Senegal, Togo, Upper Volta

Chairperson Mark Wentling, Associate Director, Peace Corps Togo

Cochairperson Vince Abramo, Public Works Specialist/Africa Region

| <u>Country</u> | <u>Name of Delegate</u>   |
|----------------|---|
| Cameroon       | Robert Vaughan, PCV   |
| Chad           | Dean Lanternier, PCV<br>Gregory Greenwood, PCV<br>Anthony Johnson, PCV<br>Ken Ribyat, PCV   |
| Dahomey        | J.P. Garrett, PCV<br>Robert Hellyear, PCV   |
| Liberia        | K. Cobb, APCD<br>Gus Waters, UNDP well-driller  |
| Niger          | Alan T. Miller, APCD<br>Willie Russell, PCV<br>Steve Simmons, PCV<br>Lee Yellott, PCV   |
| Senegal        | Thomas Gilroy, PCV<br>Robert McGurn, PCV<br>Steve Seidman, PCV  |
| Togo           | Louis Dumouchel, PCV<br>William Wallace, PCV<br>Daniel Goetz, PCV<br>Christopher Henny, PCV<br>Peter McDonald, PCV<br>William Ryan, PCV<br>Mark Lemberger, PCV<br>Wesley Stone, PCV |
| Upper Volta    | Phil Collidge, PCV  |

OTHER PARTICIPANTS:

Stan Remington

AID Hydrologist

Bill Tilton

Regional Training Officer

James Winter

Director  
Projets Techniques Sociaux  
Atakpame, Togo

James Rugh

Director  
World Neighbors, West Africa



**PART III**

**GROUNDWATER WELLS-**

**TECHNICAL REALITIES**

**C. Mary Upper Volta, FAC**

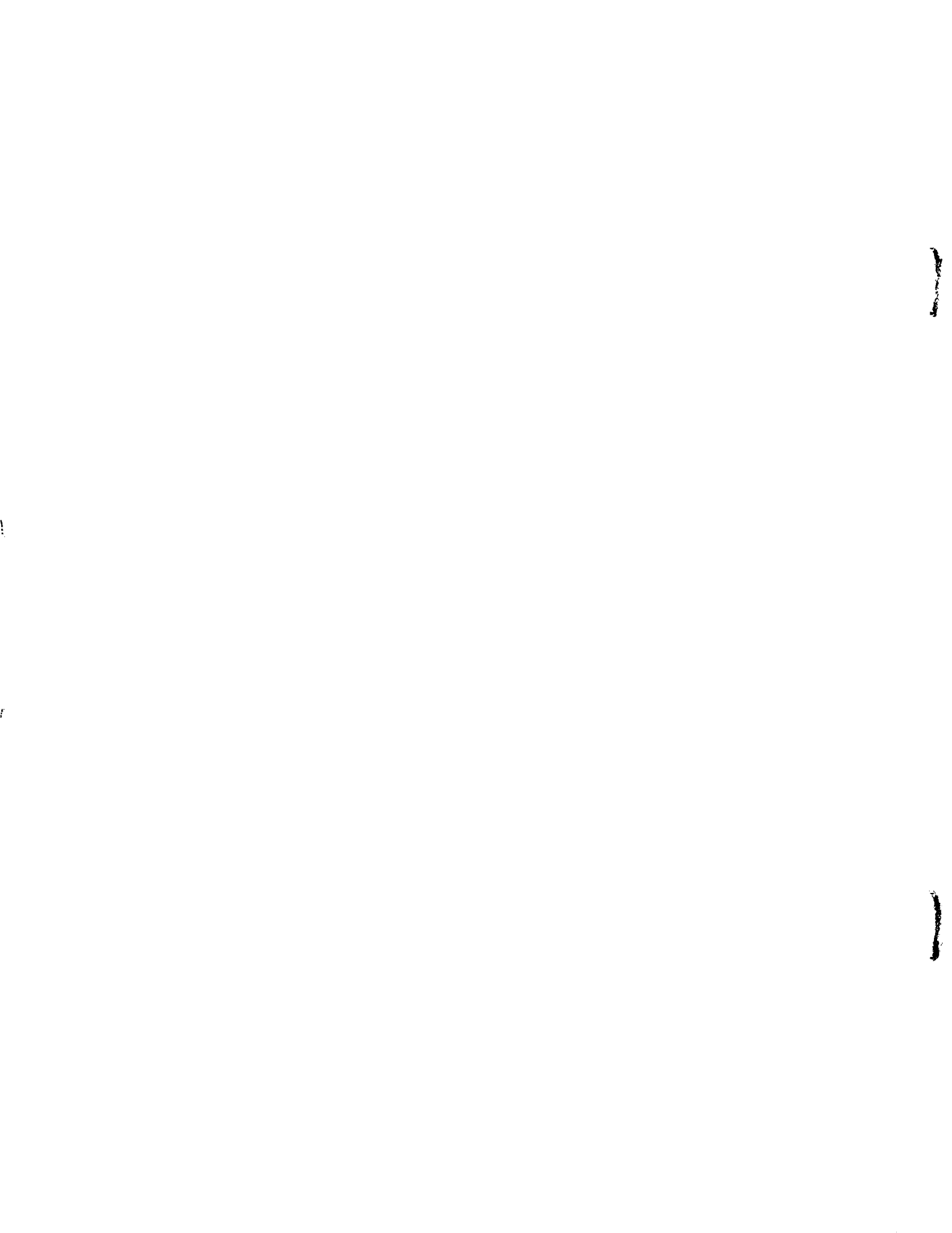

## GROUNDWATER WELLS:

### TECHNICAL REALITIES

C. Mary

The following collection of notes is to enable technicians to understand most elements of well-digging, well-building and well-driving operations, and some of the inherent problems.

Everyone seems to know what a well is. A well seems so easy to dig, build, and deepen that as soon as there is a financial possibility, everyone, from the top to the bottom of the technical hierarchy and even outside of it, thinks they can construct a well better than anyone in the past. Months or years after completing the well when self-styled well-diggers return to their sites, the evidence is painfully clear. Their methods were not better than those tried by others in the past. The great amount of optimistic reporting was mere self-delusion; the best techniques did not achieve much more than the worst. Some wells are dry, others are filled with loose soils or mud, in others the concrete has deteriorated or sunk down, and still more are settled on bed-rock too solid to produce water even after onerous excavation with dynamite.

Groundwater wells fail for several reasons:

- A) Water well-digging and building technique is the Cinderella of civil engineering.
- B) Considering the variety of soil characteristics, the techniques of building and driving into groundwater ought to be adapted to every sort of soil and grain size.
- C) In areas condemned to low annual rainfall and a very long dry season, and areas mostly covered by laterite crust or decomposed granite, it would seem clearly a prerequisite to investigate the area for sites where the soil is capable of storing large quantities of water. Yet this is rarely done and is the main cause of well failure.
- D) In tropical areas where the water supply is at a critical level, the Administration should supervise and standardize techniques of building wells so that no one, government or private enterprise, can choose a method that would be a failure. Failure is very onerous and has a bad psychological effect on the water-deprived population. The Administration should select the method that is best and longest tested in different soils. But this is not done often enough and remains an important cause of failure.



E) Some failures, unfortunately too numerous, are caused by a certain quality of worker who is unable to adapt himself to new methods although he realizes the shortcomings of his ancient ways.

### LOCATION OF WELL SITES

Until the beginning of this century underground water was located by water diviners who sometimes were also well-diggers. These water diviners worked for the most part in the country in which they were born. Most of them were farmers and ranchers and knew their country so well that from father to son they could tell which site was best for a productive well. In fact, unknown to them, the surroundings influenced their choice. Flora, topography and nature of soils, as much if not more than their rods and pendulums and other "abracadabra", influenced them in choosing a site.

To prove what I write I have only to mention that when a successful water diviner is called on consultation out of his country, his work in an unknown area is at least fifty percent failure, while in a familiar area he is successful ninety to ninety-two percent of the time.

Today when site location is done rationally it follows one of two operations:

1. Soil resistivity measures.
2. Investigative drilling.

The most concrete results are produced by a small-bore drilling survey.

I have observed that interpretation of resistivity results is often incorrect:

A) Where resistivity measures led one to believe that the subsoil was a layer of argillaceous arena, the well met decomposed gneiss without any clay or kaolin. The layer of scarcely decomposed gneiss was succeeded by very hard gneiss that only dynamite could shatter. That well produced very little water.

B) The most spectacular failure was observed on a high plateau 900 meters above sea level and 230 meters above a river whose output was invariable throughout the year. There, resistivity measures led one to believe that an impermeable layer of soil lay 35 meters deep across the whole plateau. At that site wells were dug down to 72 meters without finding impermeable soil, but at 35 meters we had hard work digging through a ferruginous layer 13 meters deep, that produced no water. The only water we found was 60 meters below the surface and that disappeared completely after some days.

Resistivity measures on that site being a failure, we appealed to a driller who came with a heavy drill rig. He had to drill past 300 meters to find impermeable soil, but there the great quantity of water could not be measured nor exploited. Water was found 76 meters under the level of the river, which was about fifteen kilometers away.

In short, during selection of well sites one should not forget that water underground is like blood in an animal's body; there is some flowing everywhere, but in the privileged points there flows much more. It is the job of the clever research driller to detect the privileged points.

In tropical areas, sites were chosen after the following observations:

1. Productivity of traditional wells and sumps in the area (wells dug by peasants that could never get deeply into groundwater)
2. The nature and relationship of clearings
3. Topography of the area
4. Flora

Such criteria produced ninety to ninety-two percent positive wells (as much as the water diviners in the area) in an area of homogeneous ground and smooth topographic landscape. The average log of such an area was:

from level 0.00 to 0.30 meters - loamy sand

0.30 to 5.00 meters - laterite crust

5.00 to 20.00 meters - iron-bearing silt and loose soil

After deepening, wells in such an area contained four to six meters of water, and even in regions of moderate outcropping results were the same. Water diviners and soil specialists got about the same results:

32% of holes were abandoned--they never hit water. The rock was shale, schist or greenstone.

55% got five meters into water and met hard rock.

13% got more than five meters into the water table. They reached hard rock after passing through very decomposed granite or gneiss with a large grain.

Of the 55% of wells that have less than five meters of water, perhaps half will not supply water after the fourth month of the dry season, so that from that time more than 50% of the holes are useless. This is too expensive and inefficient.

Conclusion: Surface criteria such as topography, flora, nature of surface soils, and rocks are successful everywhere that it is inevitable to find water (in quantities of varying importance).

Since resistivity and other measures are liable to misinterpretation, there remains only one way to rationally choose well sites: It is to bore investigative holes at prospective sites so as to avoid misleading interpretation and to know for certain the nature of the subsurface.

A linear meter of boring costs about \$20 (1971).

A linear meter of abandoned well costs about \$80 (1971).

### WELL DIGGING

In the past a well's diameter was small not only to limit the volume of earth excavated but also to enable the workers to climb in and out without a ladder, by means of notches cut in the wall. In present-day tropical Africa things look different because well-digging has become a collective enterprise financed by international organisations that permit acquisition of tools and mechanical equipment.

When a test bore has been done before digging, digging and building can be done from the top to the bottom of the well. When test drilling has not been done, digging must proceed until one finds groundwater; then sounding of the water table should be done and building can begin from bottom to top. This method insures the presence of water and indicates the depths and nature of the water table before construction begins. It is essential with unskilled and unpaid labor.

Sometimes in granitic or gneissic soil wells may intercept a very loose, moist eluvium. One cannot then conclude that there is a sufficient amount of water in the layer, and construction should not begin before sounding the eluvium. Without preliminary soundings, many wells built on these moist soils produce water at the rate of only ten buckets per day because the layer was shallow and impenetrable bedrock was lying underneath. These wells are unproductive three months after the last rainfall.

### SELECTION OF DIAMETER

It is common to hear wells specialists say, "The larger the diameter of the well, the greater the recharge rate, and moreover large diameter wells will accumulate more water during idle hours." The last proposition is certainly true, but the first needs some additional thought. The output capacity of wells and boreholes depends on diameter, permeability of the aquifer, and

height of drawdown. We know that:

- A) The diameter of hand-dug wells is greater than those that are machine bored.
- B) A small diameter hole will penetrate deeper into the water table than a large one.
- C) Drawdown in a borehole is at least twice as great as in a large well.
- D) The importance of diameter is outweighed by the importance of drawdown height.

Conclusion: A small-bore hole penetrating deep into the aquifer will yield more water than a large-diameter well sunk only partially into the aquifer. The first proposition would have been true if the large-diameter well could reach as deep into groundwater as the borehole.

In terms of cost, large-diameter wells are more expensive. They are dug to a lesser depth and are more likely to dry up than smaller boreholes.

The difference in penetrating ability between large and small wells is illustrated by the different-sized wells built by the technical administration, private enterprise, and other organisations. With unpaid, unskilled labor supplied by the rural population, the government and other organisations built some wells with a 1.80 meter diameter and others with a 1.40 meter diameter. The former were dug with some difficulty 1.5 meters into groundwater, while the latter reached two or three meters below the water table. Why? Because a 1.80 diameter well yields 2550 liters of water per meter of depth, as opposed to 1540 liters from the 1.40 diameter well. Because the removal of water by hand is very slow, the small diameter well can be emptied long before the large one so that the workers have more time for digging. By the time a large diameter well is emptied, it is too late in the day to resume excavation.

We have discussed this problem in terms of unpaid labor, but even removing water by means of a sump pump produces about the same difference in penetrating ability.

From all this one should not conclude that the narrower a well, the better it is. This would ignore some real facts:

- A) For manual excavation a certain working space is necessary. The worker must move easily to be efficient.
- B) Many wells encounter loose soils. The diameter of the well should allow the construction of the outer concrete shell and of a second concrete column descending inside the first one.

These two points lay stress on ease of construction rather than on water output.

In the past people said that a one-meter diameter was ideal, but in such a restricted space the worker loses time and efficiency. Moreover, in the case of loose soils it is impossible to sink a second column. In those days time was not money, as it is now.

Experience has shown that the ideal inner diameter is between 1.20 and 1.60 meters. Both government and private enterprise have chosen 1.40 meters in most parts of Europe and America. Some administrations choose 1.80 inner diameter on the pretence that it permits more buckets to take out water in the same amount of time. This was and is a dreamy miscalculation economically, and worse practically.

### BUILDING METHODS

In ancient times wells consisted of a masonry cylinder that was supported by the first layer of solid rock. This construction held back loose surface soils and insured against contamination by surface water. Materials consisted of squared stones or bricks.

When it was necessary to build down into water, an annular wall of squared stones was erected without mortar; each layer of stones was offset horizontally to provide strength. The wall was settled on a flange of shaped limestone a little wider than the column. Water filtered into the well through the loose joints of the stones and the capturing column functioned because the seepholes were distributed uniformly through the full depth of the water. The illogical and dangerous system of catchment through the base of the well was avoided.

With the invention and popularization of reinforced concrete, the techniques of well construction developed rapidly because great strength could be obtained with only a thin concrete shell. But lack of civil engineering codes for well construction did not make a choice easy; many decided to build by stacking prefabricated elements or pipes, others chose to use the mold inside the well to pour the column of reinforced concrete between the mold and the well's earth wall.

Using the method of prefabricated elements we soon found:

- A) Prefabrication of pipes or sections of pipes is not usually done at the site. Thus there are transportation costs as well as the risk of damage.
- B) Pipes more than one meter in diameter require a heavy winch.
- C) To stack one pipe on the other is difficult when the ground is loose.

There is difficulty in keeping the column vertical and danger to the worker.

- D) Prefabricated pipes do not adhere to the ground. There is no friction between the soil and the concrete and in loose ground the whole structure could collapse or sink away. Also, because it is difficult to adequately compact filler soil in the gap between the pipe and the earth wall, the well will be prone to contamination and erosion by surface water passing through this gap.
- E) Should two of the concrete flanges subside at slightly different rates, all of the pipes between those flanges can move out of joint. Loose soils will flow into the well and the whole unit can be lost forever.
- F) If each pipe is fabricated in separate sections or arcs and the joints between the sections are not finished carefully, the seams will crack and moisture will weaken the iron reinforcing rod.
- G) The energy expended and the costs of transportation and installation are significantly greater than for the mold-on-the-site method.

Prefabricated elements do have a few advantages. Concrete thickness is regular and the concrete will be better compacted. Also prefabricated pipes can be made during the rainy season.

However, these advantages will never outweigh those presented by the use of an internal mold, the external mold being the ground. This method offers these advantages:

- A) The materials are lighter and no winches are necessary.
- B) The column is monolithic.
- C) Concrete flanges are not necessary. Since manual excavation produces many minor protrusions and hollows, the adherence between concrete and ground is superior to that of flanges spaced arbitrarily along the column.

#### REINFORCED CONCRETE: SHELL OR WALL THICKNESS

People often state that the thicker the concrete casing, the stronger it is! Thus casings twenty centimeters thick were built, but since thickness was increased so as to diminish the need for iron reinforcement, the cement was not reinforced enough. (The thicker the concrete, the more iron is needed.) Makeshift reinforcement without horizontal circles was tried, and everywhere that the wells were built in solid ground the casing did not break. However, everywhere casings were built in loose ground they collapsed one to five meters from the bottom, and some were abandoned when they threatened the workers'

safety. Thus the theory that greater thickness provides greater strength proved to be quite false.

After many years of failure it was agreed that the concrete casing of a well had to be subjected to a study as precise as for any other engineering work, after experimenting technicians agreed that the thickness of the casing is sufficient when it equals one-tenth of the inner radius of the well. Once technicians decided to build according to the norms of reinforced concrete construction, thin casings no longer collapsed even when they extended through fluid soils ten and twelve meters below the water table.

Attached to these notes are drawings showing types of reinforcement and amounts of iron rod that vary according to the nature of the soil and building procedure (from top to bottom or bottom to top).

### DESCRIPTION OF A WELL

The different parts of a well are (from top to bottom):

1. THE RIM
2. THE APRON (flat concrete slab around the rim)
3. THE CASING (annular vertical wall)
4. THE PERFORATED CONCRETE CAPTURING COLUMN
5. THE CUTTING DEVICE (on which the capturing column rests)
6. THE CIRCULAR CONCRETE BOTTOM SLAB

The main casing generally ends at the water table.

The capturing column is sunk into the aquifer, and should even pass through that layer as far as possible to settle on hardpan. When digging penetrates solid ground or rock a mobile capturing column is not necessary and would be difficult to drive. In such cases the main casing plays the part of the intake device from the upper level of groundwater to the bottom of the well, and we have a uniform diameter from top to bottom.

When digging encounters very fluid soils, loam, silt or clay, it is essential that the main casing end at the water table. This is not too often said.

If loose soils at the water level do not permit placing the cutting device mold, the bottom of the well should be filled with 20-30 cm. of fine gravel which will give a stable base and allow the worker to construct the cutting device and capturing column.

The cutting device is a concrete circle whose bottom is a triangular edge sharp enough to cut through the ground. The dimensions of the cutting device

should be calculated so that the surmounting column is free of most ground friction and can sink easily during excavation. Thus the external diameter of the cutting device is at least 12 cm. larger than the external diameter of the column and is at least 6 cm. smaller than the column's internal diameter.

The intake or capturing column is a concrete pipe open at both ends and driven into the ground by excavating from the center of the cutting device. The column should be perforated so that the water will not come in from the bottom only; it is imperative that water enter the well laterally through openings distributed evenly over the total depth of the aquifer. Perforations can be ten to twenty times the size of the smallest soil particle.

The most useful part of a well is that which is underwater, but it is usually more difficult to build and sink the capturing column than to build the main casing. In very stable ground composed of fissured rock, it is a waste to build the column because it slows the free flow of water through the cracks.



WELLS PARTS DIMENSIONS

INTERNAL DIAMETER 1.40 meter

INTERNAL DIAMETER 1.80 meter

|                                |                  |            |
|--------------------------------|------------------|------------|
| Sinking or external diameter   | 1.54 meter       | 2.00       |
| Internal diameter of casing    | 1.40 "           | 1.80       |
| Casing concrete thickness      | 0.07 "           | 0.10       |
| Rim " "                        | 0.07 "           | 0.10       |
| Rim height                     | 0.70 "           | 0.70       |
| Width of apron                 | 1.00 "           | 1.00       |
| Concrete apron thickness out   | 0.06 "           | 0.06       |
| " " " in                       | 0.15 "           | 0.15       |
| " " bracket thickness          | 0.35 "           | 0.35       |
| Cutting device ext.diameter    | 1.34 "           | 1.60       |
| " " int. "                     | 0.94 "           | 1.10       |
| " " jutting out                | 0.08 "           | 0.05       |
| " " " ext. "                   | 0.06 "           | 0.10       |
| " " total height               | 0.40 "           | 0.45/0.50  |
| Capturing column Ø ext.        | 1.22 "           | 1.40       |
| " " int.                       | 1.00 "           | 1.20       |
| " " minim. height              | 4.00 "           | 4.00       |
| " " concrete thick.            | 0.11 "           | 0.10       |
| Concrete slabs bottom & top    | 0.06 "           | 0.06       |
| Linear meter excavation volume | 1.85 cubic meter | 3.14 c.m.  |
| " " concrete casing "          | 0.33 " "         | 0.596 c.m. |

-----

To some wells are adjoined drinking trough:

|                              |        |      |
|------------------------------|--------|------|
| Trough internal diameter     | 1.40 " | 1.80 |
| " external "                 | 1.80 " | 2.20 |
| " concrete bottom thick.     | 0.10 " | 0.10 |
| " squared stones wall thick. | 0.20 " | 0.20 |

## CONCRETE REINFORCEMENT

Concrete is reinforced with iron rod to resist tensile and shearing stresses. Tensile stress endangers the main casing only when it is built into loose soils; in hard ground or solid rock, pulling and shearing stresses are not present.

The apron is under complex compressive, tensile, and shearing stress according to the nature of the ground. Concrete by itself is not resistant to tension and shearing, but only to compression. To create strength, iron bars are added after careful study and calculation of the particular stress.

When it is vertical, the capturing column is only under compression stress, but as it descends lateral movements of the soil may cause shearing, and reinforcement calculations should allow for this incidental stress.

With unpaid, unskilled labor, reinforcement is the most difficult part of the work to control.

One must not forget that for wells penetrating alternate layers of hard and loose ground, reinforcement is the most important element of the work. When the iron rods are badly fashioned or poorly distributed through the mass, even the best concrete will crack. What follows is the result of precise calculation of concrete and iron resistance. It would be tedious to explain all the calculations here and would have no practical value for those without technical training.

QUANTITY AND SIZE OF IRON RODS PER LINEAR METER OF CASING

APRON, RIM, CUTTING DEVICE AND CAPTURING COLUMN

-----

| <u>EXTERNAL DIAMETER OF CASING:</u>               |                           | <u>1.54 meter</u> | <u>2.00 meter</u> |
|---|---------------------------|-------------------|-------------------|
| MAIN CASING: Iron rods size 6 mm., 30 rods per M. |                           | ∅ rods 8mm        | 25 to 37 rods     |
| the above rods are vertical ones.                 |                           |                   |                   |
| Horizontal iron rods size 6 mm.,                  |                           | 5 " " "           | 6mm 5 "           |
| <u>APRON</u>                                      | 8 mm ∅ iron rods radial   | 30 per unit       | 30 p.u.           |
|   | " " brackets "            | 30 " "            | 30 "              |
|   | 6 mm ∅ iron rods circular | 6 " "             | 6 "               |
| <u>RIM</u>  | 8 mm ∅ iron rods vertical | 25 " "            | 25 "              |
|   | 6 mm ∅ " " horiz.         | 4 " "             | 4 "               |

CUTTING DEVICE

|                         |         |                    |      |
|-------------------------|---------|--------------------|------|
| 6 mm ∅ iron rods frames | 28. " " | ∅ 8 mm rods frames | 30 " |
| " " " circular          | 7 " "   | ∅ 6 mm " circular  | 6 "  |

INTAKE DEVICE OR CAPTURING COLUMN

|                           |              |            |
|---------------------------|--------------|------------|
| 6 mm ∅ iron rods vertical | 20 per meter | 25/30 P.M. |
| " " " horiz.              | 2 per 0.75   | 6 "        |

-----

N.B. Water intake device or capturing column for wells 1.40 m. internal diameter is not the same design as for the 1.80 diameter wells. Number of rods is given for one linear meter of concrete for casing and intake column.

## CONCRETE AGGREGATES - DOSAGES

---

Present a good material with mixing of:

800 liters gravel + 400 liters of sand + 300 to 350 kgs. cement per cubic meter of concrete.

Sand should be clean and from all sizes 0 - 5 mm.

Gravel " " " " of " " 5 - 25 mm.

Cement should be new and powdery.

Materials can be measured by means of 40-liter capacity hand barrows or by means of waste 200-liter gasoline barrels.

Number of hand barrows capacity 40 l. for one cubic meter of hardened concrete

SAND 10 barrows = 400 liters.

GRAVEL 20 " : 800 " .

Cement 6 fifty kg. sacks for casing of well.

" 7 " " " for capturing column and cutting device.

Number of 200-liter capacity barrels:

SAND 2 barrels = 400 liters.

GRAVEL 4 " = 800 " .

CEMENT look to hand barrow dosage.

N.B. Hand barrows are more practical than buckets and barrels.

Everywhere buckets are used for dosage discount is false and fast, concrete is too poor in cement.

Practically for a 2.00 - 1.80 diameter well volume of linear meter of concrete is 0.600 cubic meter, i.e. 600 liters, that means volume of necessary aggregates is:  $600 \times 1.2 = 720$  liters.

SAND to be mixed:  $720 / 3 = 240$  liters or 6 hand barrows.

GRAVEL " :  $720 / \frac{2}{3} = 480$  " " 12 " "

CEMENT :  $\frac{300}{1200} \cdot 720 = 180$  kgs.

For a 1.40 - 1.20 capturing column we get 0.400 cubic meter of concrete per linear meter; that is, 400 liters or 400 M 1.2 = 480 liters of aggregates.

|        |                               |   |  |
|--------|-------------------------------|---|--|
| SAND   | $480 / 3$                     | = | 160 liters or 4(40 liter hand barrows) |
| GRAVEL | $\frac{480}{3} \times 2$      | = | 320 " " 8 " " "                        |
| CEMENT | $\frac{350}{1200} \times 480$ | = | 139 kgs.                               |

N.B. Practically, masons mix two and a half fifty kg. cement paper bags or three cement paper bags; that is, eleven kgs. too much against fourteen kgs. less with two and a half bags.

VALUATION OF MATERIALS QUANTITIES

-----

Preceding notes supply the necessary basis to value material quantities according to diameter and depth of wells.

Materials necessary to build one distinct part of well or one linear meter of casing or intake column -

WELLS 1.54 meter external diameter  
1.40 " internal "

---

WELLS 2.00 external diameter  
1.80 internal "

---

SUPERSTRUCTURE

APRON

|                   |                     |                    |
|-------------------|---------------------|--------------------|
| CONCRETE          | 0.800 <sup>M3</sup> | 1.00 <sup>M3</sup> |
| GRAVEL            | 0.640               | 0.800              |
| SAND              | 0.320               | 0.400              |
| CEMENT            | 240 kgs.            | 300 kgs.           |
| Iron rods Ø 8 mm. | 57 l.m.             | 64.5 l.m.          |
| " " Ø 6 mm.       | 61 l.m.             | 70 l.m.            |

RIM

|                     |                     |                     |
|---------------------|---------------------|---------------------|
| CONCRETE            | 0.227 <sup>M3</sup> | 0.480 <sup>M3</sup> |
| GRAVEL              | 0.180               | 0.384               |
| SAND                | 0.090               | 0.192               |
| CEMENT              | 70 kgs.             | 150 kgs.            |
| Iron Rods Ø 6 mm.V. | 25 l.m.             | Ø 8 mm V. 20 l.m.   |
| " " " M.            | 19 l.m.             | Ø 6 mm H. 19 l.m.   |

CASING

|                     |                     |                     |
|---------------------|---------------------|---------------------|
| CONCRETE            | 0.324 <sup>M3</sup> | 0.600 <sup>M3</sup> |
| GRAVEL              | 0.260               | 0.480               |
| SAND                | 0.130               | 0.240               |
| CEMENT              | 100 kgs.            | 180/175 kgs.        |
| Iron Rods Ø 6 mm V. | 34.5 l.m.           | Ø 8 mm V. 34.5 l.m. |
| " " " H.            | 24 l.m.             | Ø 6 mm H. 31.5 l.m. |
| Tie Wire for 15MD.  | 5 kgs.              | 5 kgs.              |

CUTTING DEVICE

|                         |                     |                         |
|-------------------------|---------------------|-------------------------|
| CONCRETE                | 0.202 <sup>M3</sup> | 0.350 <sup>M3</sup>     |
| GRAVEL                  | 0.162               | 0.280                   |
| SAND                    | 0.081               | 0.140                   |
| CEMENT                  | 60 kgs.             | 105 kgs.                |
| Iron rods Ø 6 mm Frames | 28 l.m.             | Ø 8 mm frames 33 l.m.   |
| " " " circular          | 26 l.m.             | Ø 6 mm circular 28 l.m. |

CAPTURING COLUMN (intake column) for 4 + 1 5 meters.

|                          |                     |                                     |
|--------------------------|---------------------|-------------------------------------|
| <u>CONCRETE PREFABS.</u> | 1.900 <sup>M3</sup> | Concrete in situ 2.00 <sup>M3</sup> |
| GRAVEL                   | 1.520               | 1.600                               |
| SAND                     | 0.760               | 0.800                               |
| CEMENT                   | 570 kgs.            | 700 kgs.                            |
| Iron rods Ø 6 mm V.      | 115 l.m.            | Ø 8 mm Vertical 150 l.m.            |
| " " " H.                 | 54 l.m.             | Ø 6 mm Horiz. 108 l.m.              |

DRINKING TROUGH

|                          |                     |                     |
|--------------------------|---------------------|---------------------|
| CONCRETE bottom          | 0.255 <sup>M3</sup> | 0.380 <sup>M3</sup> |
| (circular)               | 0.285               | 0.375               |
| GRAVEL                   | 0.432               | 0.604               |
| SAND                     | 0.216               | 0.302               |
| CEMENT                   | 150 kgs.            | 227 kgs.            |
| Squared lateritic stones | 1.00 <sup>M3</sup>  | 2.00 <sup>M3</sup>  |

EXAMPLE OF MATERIALS QUANTITY EVALUATION  
 FOR A WELL 25 METERS DEEP-1.54 ext.-1.40 int. diam.  
 WITH A 6 METERS HIGH CAPTURING COLUMN  
 -----

| NAMES<br>OF PARTS       | DIMENSIONS           | GRAVEL              | SAND               | CEMENT       | IRON<br>Ø 8 mm. | RODS<br>Ø 6 mm. | TIE<br>WIRE | OBSERVATIONS   |
|-------------------------|----------------------|---------------------|--------------------|--------------|-----------------|-----------------|-------------|--|
| <u>CONCRETE CASING</u>  | : 1.54 X 1.40 X 20.  | : 5.200             | : 2.600            | : 2.000      | :               | : 1170          | : 6         | :  |
| <u>APRON</u>            | : 3.54 X 1.40 X 0.12 | : 0.640             | : 0.320            | : 240        | : 57            | : 61            | : 0.5       | :  |
| <u>RIM</u>              | : 1.54 X 1.40 X 0.70 | : 0.180             | : 0.090            | : 70         | :               | : 44            | : 0.5       | : Could be adorned<br>with squared lat-<br>eritic stones<br>masonry. |
| <u>CUTTING DEVICE</u>   | : 1.34 X 0.94 X 0.40 | : 0.162             | : 0.081            | : 60         | :               | : 54            | : 0.5       | :  |
| <u>CAPTURING COLUMN</u> | : 1.22 X 1.00 X 6    | : 1.800             | : 0.900            | : 875        | :               | : 169           | : 2.5       | : PREFABS.   |
| <u>DRINKING TROUGH</u>  | : 1.80 X 1.40 X 0.30 | : 0.432             | : 0.216            | : 150        | :               | :               | :           | :  |
| TOTAL                   |                      | : 8.412             | : 4.207            | : 3.395      | : 57            | : 1.498         | : 10        | :  |
| MAJORATION              |                      | : 1.588             | : 1.793            | : 508        | : 6             | : 150           | : 1         | :  |
| END TOTAL               |                      | : 10 M <sup>3</sup> | : 6 M <sup>3</sup> | : 3.903 KGS: | 53 m.           | : 1.648 L.M.:   | 11 KGS.     | :  |

33



EXAMPLE OF MATERIALS QUANTITY EVALUATION  
 FOR A 25 METERS DEEP WELL Ø 2.00 ext. 1.70 int.  
 WITH 6 METERS HIGH CAPTURING COLUMN  
 -----

| NAMES OF PARTS          | DIMENSIONS            | GRAVEL  | SAND    | CEMENT  | IRON RODS |        | TIE WIRE | OBSERVATIONS |
|-------------------------|-----------------------|---------|---------|---------|-----------|--------|----------|--------------|
|                         |                       |         |         |         | Ø 8 mm    | Ø 6 mm |          |              |
| <u>CONCRETE APRON</u>   | : 4.00 X 1.80 X 0.12  | : 0.800 | : 0.400 | : 0.300 | : 64.50   | : 70   | : 0.50   |              |
| <u>RIM</u>              | : 2.00 X 1.80 X 0.70  | : 0.384 | : 0.192 | : 0.150 | : 20      | : 19   | : 0.50   |              |
| <u>CASING</u>           | : 2.00 X 1.80 X 20    | : 9.600 | : 4.600 | : 3.600 | : 690     | : 630  | : 7      |              |
| <u>CUTTING DEVICE</u>   | : 1.600 X 1.10 X 0.45 | : 0.280 | : 0.240 | : 0.105 | : 33      | : 28   | : 0.50   |              |
| <u>CAPTURING COLUMN</u> | : 1.40 X 1.20 X 6     | : 1.820 | : 0.912 | : 0.805 | : 126     | : 130  | : 1.50   |              |
| <u>DRINKING TROUGH</u>  | : 1.60 X 1.10 X 0.45  | : 0.604 | : 0.302 | : 0.327 | :         | :      | :        |              |

|            |                        |         |           |           |          |         |   |
|------------|------------------------|---------|-----------|-----------|----------|---------|---|
| TOTAL      | : 13.488               | : 6.546 | : 5.287   | : 933.50  | : 877    | : 10    | : |
| MAJORATION | : 1.312                | : 654   | : 713     | : 96.50   | : 83     | : 1     | : |
| END TOTAL  | : 14.800 <sup>M3</sup> | : 7.200 | : 6.000 T | : 1030 ML | : 960 ML | : 11 kg | : |

34



## DESIGN OF MOLDS

Whatever kind of labor used, skilled or unskilled, paid or unpaid, metallic molds should be:

1. Conceived according to strength of man and to stress applied to the molds.
2. WITHOUT hinge or articulation.
3. Each bow of a cylinder must be equal and identical to the other bows.
4. Molds should be easily dismantled and removed.
5. Fastenings should be easy to fix and to unhook.
6. Every time it is possible molds should be conceived for different purposes of different methods:
  - A) External mold of edge may serve to external mold of big size capturing column (  $\varnothing$  2.00 M external diameter ).
  - B) Inside mold of capturing column should allow to use molds with perforation device without being solidary to it.

## DRIVING THE CAPTURING COLUMN:

### PUMPS AND UNSKILLED LABOR

It is very easy to get masons and workers to build the main casing of a well, but when it comes to building and sinking the capturing column it is much more difficult:

- A) Sinking the column is very difficult. If not guided properly it may incline, in which case it must be abandoned.
- B) The descent of the column may allow fluid soils to enter the well.
- C) The method demands much more care and skill from masons and workers.

No matter how skilled the workers may be, they cannot drive a capturing column through loose soil without a minimum of tools and equipment. In the tropics the electrical power network is not extended enough to allow the use of electric sump pumps or rock drills. Portable generators are uneconomical and almost never adapted to the tools, and furthermore, electrical equipment often breaks down even when serviced by skilled mechanics. It has been proven that electrical apparatus fails in a very short time outside of large towns.

To work safely in a well it is necessary that mechanical breakdowns be kept to a minimum. Since electrical apparatus is not failure-proof, it is better to employ pneumatic machines and tools. Then when the tool becomes overburdened, the compressor also is overloaded and automatically decelerates. The tool is not destroyed as can happen when electric motors overheat.

The method of pumping while digging is very illogical, especially in loose soil. But with unskilled labor, people thought it was the only way to sink an intake column through the water table. (See technical notes.)

PNEUMATIC MACHINES AND TOOLS NECESSARY

1 COMPRESSOR, whose capacity should allow for the consumption necessary for a big sump pump + 10%; or the consumption for two light sump pumps + 10% since other tools consume less than a sump pump.

One or two sump pumps (two light sump pumps are better than one big one). Two light PUMPS can be coupled and they will be more efficient than one big one. For wells of twenty meters, a light pump and other pneumatic tools can be used simultaneously.

2 CONCRETE BREAKERS not less than 25 kgs.

10 NEEDLES per pneumatical breaker.

1 JACKHAMMER not less than 25 kgs. weight. SHANK 108 - Hex 22 mm.

5 DRILL STEEL Hex. 22 mm. SHANK 108. Length 0.50 m. Or 0.60.

5 " " " " " " " 1.00 m. Or 1.20.

5 " " " " " " " 1.50 m. Or 1.70.

15 DETACHABLE CROSS BIT for above drill steel, rope threaded, external size minimum 38 mm., maximum 41 mm.

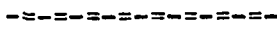

SUMP PUMPS COULD BE: I.R. 225 consuming 2.200 liters air per minute.

Or P.O. 570 " " " " " "

coupled they consume  $2 \times 2.200 = 4.400$  liters per minute.

COMPRESSOR CAPACITY should be  $4.400 + 10\% = 4800$  liters per minute

BREAKER consumes 1.100 to 1.800 liters per minute.

JACKHAMMER " 1.500 to 2.100 " " "

SO SELECTION OF COMPRESSOR DEPENDS ONLY ON SUMP PUMP CONSUMPTION.

Don't forget; an elephant can pull a horse, but a horse can't pull an elephant.

UNSETTLED TECHNICAL PROBLEMS:  
COMPARATIVE SIZE OF WELL CASING AND INTAKE COLUMN

When selecting the size of their intake column, many people ignore the problems involved in descending the column and think only of the volume of water that can be held. As a result many columns descend and are lost (technically) because the gap between them and the main casing is too large. This gap should not be more than 10 cm. on all sides.

In a 1.80 meter well, for example, the intake column's external diameter should be 1.60 meters. An intake column of 1.40 meter external diameter should be used for a 1.60 meter casing. That provides enough space for a filter of gravel 5-15 mm. in size.

SIZE AND SHAPE OF INTAKE COLUMN PERFORATIONS

Small perforations? Horizontal or vertical ones? Circular, cylindrical or rectangular? What is good, what size is best, what shape is most effective?

Small cylindrical holes are advantageous in the following soil conditions and only in them;

1. Large sand (more than 0.5 mm.)
2. Large arenaceous products
3. Cobble

Small cylindrical perforations are best done when sinking is done without pumping. They are ineffective in two cases:

1. Silt and loam
2. In any fluid soil when pumping while digging.

In Case 1 the silt will clog the perforations. In Case 2 fluid soils pressing on the column penetrate into the perforations and render them ineffective. In this case only the top third of the column is free from the compression effect.

This is easily confirmed at every site where people pumped while digging. Pumping causes fluid soils to move at a speed nearly equal to that of water, and the energy involved is great enough to compact the soils against the column, which causes friction and impedes the descent.

Although technicians write that with the method of pumping while digging the column can be surrounded to the bottom by a gravel filter, this claim is false. With this method gravel will ring only the upper third of the column, while below will be compacted and immovable loose soils.

Since water in many tropical countries is to be found only in ferruginous soils, silt, loam, clay, and so on, we have to imagine a device that would:

- A) Be effective in all kinds of soil.
- B) Be effective with all digging methods.
- C) Not endanger the concrete of the capturing column.
- D) Be automatically and continually unclogged. (Clogging is what causes the failure of cylindrical perforations in loose soils.)
- E) Remove some of the compression against the exterior of the column, to ease the sinking.
- F) Allow water from the top perforation to trickle to the bottom via intermediary perforations, creating an automatic unclogging effect.

#### OBSERVATIONS ON PERFORATION SHAPE

We saw that small cylindrical perforations were effective:

- A) In soil with large grain.
- B) When sinking underwater (without pumps). But this requires specialized machinery and workers, and in our case, with unskilled labor it is impossible.

Thinking over what is written on pages 23-24, we find only one shape that is appropriate to almost all methods and kinds of soil. It must be a vertical rectangular slot.

To induce the water to trickle from top to bottom via the intermediary perforations, we should link them by a vertical channel set into the concrete.

To select the dimensions we use the following criteria:

- A) The width of the perforation should not be more than twelve times the size of the average soil grain because we benefit from the effect of contraction. Taking the average particle size as 0.5 mm., the perforation should be

$$0.5 \text{ mm} \times 12 \times 2 = 12 \text{ mm}$$

B) We know that the interval between horizontal rods in the column is 20 cm. and that over the iron there must be 2.5 cm. to protect against rust. On the column's outside face the length of the perforation should thus be

$$20 \text{ cm} - (2 \times 2.5 \text{ cm}) = 15 \text{ cm}$$

producing a slot of

$$15 \text{ cm} \times 1.2 \text{ cm} = 18 \text{ cm}^2$$

From Points D and E we see that the slot should produce decompression; the inner dimensions should be larger than the outer ones. We should double the width to 2.4 cm., and to aid the trickle effect we can increase the length without difficulty to 18 cm. The slots now in practical use are 18 x 3 cm. on the inner face of the column and 15 x 1.5 cm. on the outer face.

Concerning Point F, the vertical channel that connects the perforations is imprinted by the flat iron strip that supports the perforation molds. Thus the strip serves two purposes, It should be 3 mm. thick.

#### NUMBER OF PERFORATIONS

To be practical, the perforations must not endanger the column's strength. From calculation and experience we have found that:

- A) In conditions of low lateral compression, a maximum of twenty perforations per meter of depth is possible without danger to the column (in wells dug under water or in large-grained soil).
- B) Where there is much pressure on the walls, the perforations should be wider apart. Experience has shown that ten perforations per vertical meter cause no problems in the event of shearing stress caused by the nefarious "pump and dig" method in loose soils.

§§§§§§§§§§§§§§§§

Recently some engineers and technicians have criticized the shape of the perforations described here as dangerous for concrete. However, as long as they do not provide proof for their pet theories, we must think that these theories are born from the will to promote their preconceived "small circular perforation," which we can prove ineffective every time the column is driven into loose soils (and with either digging method).



Because of this confusion, work foremen were unsure which method to use and began to leave the bottom of the well without any perforations, which is completely irrational because:

The most interesting level of groundwater is the extreme bottom. As nobody is insane enough to refute that truth, it comes logically that perforations must start at the base of the column and proceed to the water table, i.e. they must be uniformly distributed through the total depth of groundwater.

As the critics claimed a diminution of concrete strength, we ought to do some thinking. At the base of the column is a piece of concrete that is the strongest part of the whole structure. Why? Because the cutting device was calculated to resist not only the stress of cutting the ground, but also to reinforce the base against all types of stress. Before criticizing at random, people should calculate the resistance of the cutting device concrete and study the shape I gave it.

Even though the most productive level of water is at the base of the column, it still should be perforated from bottom to top. But there is one exception; wells whose diameter is much larger than the capturing column pose a problem. To prevent the column from inclining, it must be guided down by thick planks. During the sinking operations, much stress may be concentrated at the top of the column, which is at or above the water level. Thus perforations do not play a major role and the top two pipes need not be perforated. This reinforces concrete strength.

#### THE GRAVEL FILTER

With our present tropical methods (Ranney, Clause and the like excluded), in loose fine soil gravel will surround only the upper third of the column with the "pump while digging" method. When sinking underwater, gravel surrounds only the upper two-thirds of the column.

To use laterite as the filtering gravel is the worst thing that could be done. During water level fluctuations it concretionates and may become so compact that it forces water to flow down the column exterior and up through the well bottom. This is not good.

## A RATIONAL METHOD OF SITE SELECTION

In the first part of this booklet we said that site selection should not be entrusted to water diviners or surface observers in areas where groundwater is very scarce because of low rainfall and impermeable surface soils. Also that selection should depend on drilling investigations that provide the following information:

1. Soil nature and structure.
2. The groundwater's upper level and depth.
3. The specific yield of the aquifer.
4. The storage potential of the aquifer.

With this information wells should be located at the best points; but also when possible they should be placed where soil particles are large. It is economical to avoid eluvium because:

- A) Eluvium has high specific retention and does not yield much water.
- B) It is almost as mobile as water.
- C) It chokes perforations very rapidly.
- D) It is difficult to penetrate even with the "sinking under water" method.

Investigative drilling should use a 4-inch bore.

A linear meter of well costs about \$80 while a linear meter of drilling costs about \$20. Water diviners and surface observers placed wells 70% of which are dry from February to July. In areas of old granite, granodiorite, gneiss and pegmatite I observed:

Pegmatite: more than 90% positive boreholes

Granite and granodiorite: 50% positive boreholes

Gneiss and other metamorphic: 35% positive boreholes

Not to be too optimistic and to avoid error, we shall presume that only one borehole in three is positive. Thus for a program of 1000 linear meters we have:

|                                       |           |
|---------------------------------------|-----------|
| cost of investigative drilling (1971) |           |
| 1000 x 3 x 20 =                       | \$ 60 000 |
| cost of well construction (1971)      |           |
| 1000 x 80 =                           | \$ 80 000 |
| Total cost, 100% positive wells       | \$140 000 |
| Cost per linear meter                 | \$ 140    |
| -----                                 |           |
| Cost per meter, 30% positive wells    |           |
| 80 000 / (1000 x 0.3) =               | \$ 266    |

Thus investigative drilling gives an economic advantage of \$126 per meter of positive well, besides avoiding the psychological impact on the population of seeing their work go to nothing.

### SINKING AND DRIVING INTO GROUNDWATER

In Part I of this booklet I wrote that the "pump and dig" method was irrational. This is true in loose ground (silt, silty loam, silty clay, fine sand arena) because:

- A) Pumping of water sets ground grain moving toward the intake column.
- B) The radius of moving ground enlarges continually.
- C) The height of moving ground enlarges continually, causing sudden caving of the upper soil which compacts against the intake column and stops its descent.
- D) Pumping while digging has a very bad effect; it causes the gravel filter to remain around the upper third of the column height.
- E) In areas of nonsedimentary soil and poor rainfall, this method may exhaust the ground water potential and render the well useless before half the rainy season is over.
- F) Around the base of the intake column it causes a mixing of upper soil layers with the groundwater, which may decrease soil permeability.
- G) As a well becomes depleted, it becomes more difficult to obtain water from the soil. This explains why, when a well dries up, peasants find water thirty to fifty meters away and four or five meters nearer the surface in a rudimentary sump!

Sinking may be done in hard ground while pumping, because if there is a high groundwater potential it will increase the well's yield.

Thus the rational method of sinking a well into groundwater is to excavate under water, which has the following effects:

- A) The presence of water causes the intake column to glide down regularly, according to the speed of excavation. Water "lubricates" the column's outside surface.
- B) Loose soil does not move so fast toward the center of the intake column. It moves only because of light vibrations from the excavating operation, and only one fourth of the column height (instead of two thirds) is neutralized by slightly compacted soil.

- C) To get gravel to surround the total height of the intake column, a valve device must be opened after the gap between the column and the ground has been filled with mixed clean gravel. When the valves are opened the downward pressure of the gravel carries away loose soil that has entered the column. When no more silt comes in through the valves, they are closed and the gravel behind the column is replenished.
- D) Only at the end of this operation may you say that the intake is correctly done, and this is only because gravel surrounds the entire height of the capturing column.

In loose ground, excavation under water is the only rational way to get positive wells.

RATIONAL METHOD OF SINKING POSITIVE WATER WELLS  
TOOLS AND MACHINERY

Handtools are the same as for Part I.

INVESTIGATIVE DRILLING

The drilling outfit should:

1. Be sturdy but not too heavy;
2. Drill a 4-inch borehole;
3. Drill by rotation and percussion;
4. Be highly efficient;
5. Provide core samples;
6. Be operated by experienced drillers and mechanics.

EXCAVATING UNDER WATER

This operation should be done by divers with special diving equipment. Handtools are the same as for Part I. When excavation is done with machinery and excavating buckets, the outfit should include a heavy crane, of the Benoto type for example.

MISCELLANEOUS

To work easily when excavating under water:

- A) The cutting device must not project inside the capturing column, as the excavating bucket will strike and break it.
- B) The concrete of the capturing column should be reinforced with more than the usual number of horizontal iron rods. These rods should be at least 6 cm. apart at the base of the column (first two meters) and the number can lessen with height.
- C) The above reinforcement does not permit rectangular perforations at the base of the column, but cylindrical ones may be used since without pumping, loose soil will not choke the perforations.

-----

When you select tools, keep in mind the sort of work you want done and the sort of workers you have.

With a compressor do not forget that several light tools that can be coupled are better than one high-capacity tool that may often be too powerful. Two coupled light tools are often more powerful than one heavy one. Besides, when one light tool is convenient on one site you can separate your tools and work on different sites simultaneously.

For three compressors you should get:

- 1. One heavy tool, not to be coupled.
- 2. Four light tools to be coupled. (pumps, jackhammers, paving breakers)

Then you have tools for every sort of special work.

-----

When someone tells you that he sank a well that will never dry up, don't believe that lie. All things dry up some day, some year. Only human silliness never passes.

C. MARY

**PART IV**

**SAMPLE PROPOSALS**

**CONTRACTS**

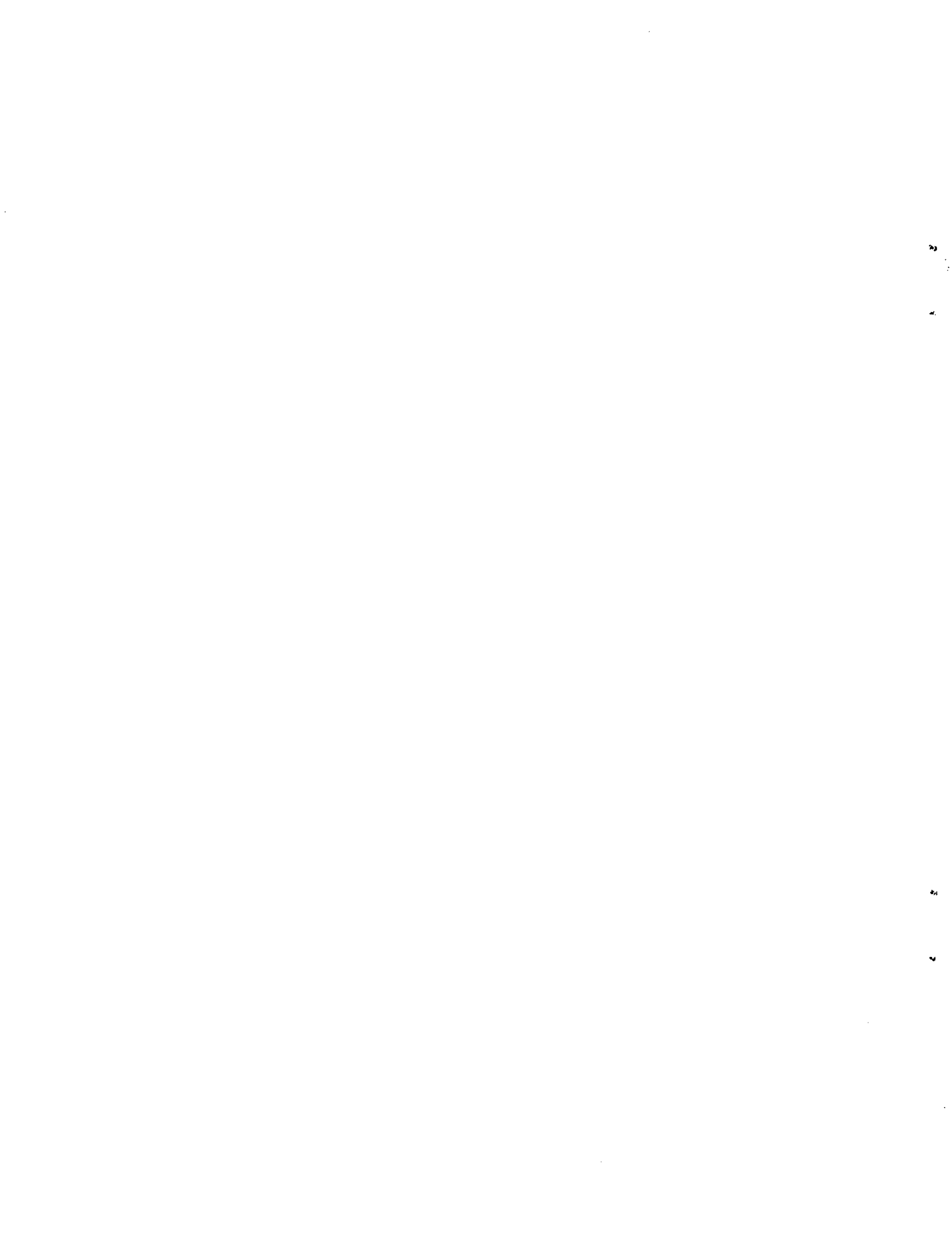

# 1. PROPOSAL, UPPER VOLTA

EMBASSY OF THE  
UNITED STATES OF AMERICA

B.P. 55

Ouagadougou, Haute Volta

August 6, 1974

Directeur du Plan et des Etudes de Development  
Ministere du Plan, de Developpement Rural, de  
l'Environnement et du Tourisme  
Ouagadougou, Haute Volta

Dear Sir:

Pursuant to Section 2-2 of the Grant Agreement between the Government of Upper Volta and A.I.D., the purpose of this letter is to set forth for activity Number 686 - such descriptive, budgetary and administrative information as is considered sufficient to satisfy the condition of Section 2.2. As such, the issuance of this letter shall constitute notification to all parties concerned that the conditions precedent to disbursement for this activity have been satisfied.

## Description of the Activity

Upper Volta, as a result of its climate and surface geology, is one of the most disadvantaged states of West Africa in terms of water resources. The immediate consequence of the chronic lack of rainfall is the present drought, whose effects are being suffered throughout the Sahel.

Enough water to satisfy the needs of the population, a preliminary step in any sort of economic development is one of the priorities set by the Government of Upper Volta in its Second Five-Year Plan for 1972-76. The Direction of the Hydraulic and Rural Construction Service, hereafter referred to as H.E.R., under the Ministry of Planning, Rural Development, Environment and Tourism, administers programs in water management involving irrigation, wells, large and small dams, lowland management, etc. One of the most important and significant programs is wells construction.



The wells construction program strikes at the most immediate drought effect: lack of potable drinking water. Additionally, the program creates long-term infrastructure development in rural areas, as these wells can later become the basis for gardens, dispensaries, tree nurseries, and animal watering troughs.

H.E.R. directs a number of international organizations in well-digging programs throughout the country: the Peace Corps is the largest single contributor in this area, having completed over 1200 wide-diameter cement wells since 1967. The Program's most outstanding features are integration at all levels, stress on human investment and, consequently, low cost per meter. A history of success is already well established.

H.E.R. and the Government of Upper Volta have requested the continued presence of fourteen Peace Corps Volunteers to oversee and coordinate the construction of new wells and the repair and maintenance of old wells in the Sous-Prefectures of Kongoussi, Boulsa and Zabre. Each Volunteer will live in a village and be responsible for the Wells Program in the area around him. The people of the villages concerned will provide the necessary labor on a self-help basis, while the Sous-Prefets will be responsible for paying the salaries of locally-hired masons to be trained by the Volunteers. The Hydraulic Service will pay the cost of Volunteer housing and provide trucks for the internal transport of cement and equipment. A Peace Corps Wells Program Coordinator will work in H.E.R. to administer the Program. A.I.D. has agreed to give the sum of \$150,000 (CAF 34,500,000) to provide for all materials for the next two years.

The Program has been a major success in its contribution to short and long term rural development. The present drought necessitates continuing a strong program to maintain and increase water supplies for the rural populations.

#### Implementing Agency

Implementation responsibility for the program will rest with the Direction of the Hydraulic and Rural Construction Service within the Ministry of Planning, Rural Development, Environment and Tourism. The program manager in Ouagadougou will be M. Yaya Idrissa, Director of H.E.R. In the absence of the Director, M. Ido Dominique, the Chief of Service, will

serve as the program manager. The director of the work to be done will be Mr. Philip Coolidge, the Peace Corps Wells Program Coordinator.

Payments will be made by the Banque National de Developement upon presentation of vouchers furnished by the Direction of H.E.R. The signatures of M. Yaya (or in his absence M. Ido) and Mr. Coolidge will be required for certification in connection with disbursement requests, procurement, reporting, etc.

The cement and steel reinforcing rod will be brought underbids and awarding the contracts belongs to the Direction of H.E.R. The purchase of tools, supplies, gas, oil, and rental of warehouses is the responsibility of the Peace Corps Program Director.

### Implementation Schedule

The general work plan is based on a normal twelve month schedule, although the actual construction period for the wells runs from December to June. In the slack months the Volunteers participate in work-related projects, as continuation of the well work during the rainy season is impossible. Throughout these months, the organization and training of manpower for the coming well season is of primary concern.

- |                   |   |  |
|-------------------|---|--|
| August/September  | : | Evaluate final equipment needs from the previous year, and finalize order for new cement, steel and replacement equipment. |
|                   | : | New Trainees for the Program take French and Cross-Cultural Studies at Bobo-Dioulasso                                      |
|                   | : | The Program Coordinator meets with H.E.R. and the Sous-Prefets to plan placement of the new Volunteers                     |
| October           | : | The Technical Training takes place at Boulssa on 5-29 October  |
| November/December | : | Construction begins on 100 new wells   |
| January           | : | Construction begins on additional 100 new wells  |
| February          | : | Complete digging phase of construction for 100 new wells   |

March/April : Cement and finish construction of all new wells

May : Deepening & maintenance of existing wells

June/July : Collect equipment, inventory, submit final reports to H.E.R. and A.I.D.

Objectives/Targets

This program will target the completion of 200 new wells and the repair, maintenance and deepening of 80 existing wells by June 1975. An additional 200 new wells and 80 existing wells will be completed by June 1976, the end of the funding term. These wells will alleviate drastic water problems for some 300,000 people. This represents a major drought relief contribution and a long-term infrastructure development.

Budget

Itemized Budget: Fiscal Year 1975

1. Cement and Steel Reinforcing Rod

|    |                                      |                |
|----|--------------------------------------|----------------|
| a. | 600 tons of Cement at 20,000 per ton | 12,000,000 cfa |
| b. | 30 tons of Steel at 151,000 per ton  | 4,530,000 cfa  |

Total: 16,530,000 cfa or at C.R. \$70,335

2. Hand Tools purchased locally

|    |                 |                 |             |
|----|-----------------|-----------------|-------------|
| a. | 200 Shovels     | at 342 cfa per  | 68,400 cfa  |
| b. | 150 Picks       | at 692 cfa per  | 105,800 cfa |
| c. | 125 Pullies     | at 1950 cfa per | 243,750 cfa |
| d. | 150 Buckets     | at 1300 cfa per | 195,000 cfa |
| e. | 30 Trowels      | at 1090 cfa per | 32,700 cfa  |
| f. | 20 Hammers      | at 1525 cfa per | 30,500 cfa  |
| g. | 25 Mining bars  | at 3836 cfa per | 95,000 cfa  |
| h. | 60 Tape measure | 750 cfa per     | 45,000 cfa  |
| i. | 30 Chisels      | at 480 cfa per  | 14,400 cfa  |
| j. | 40 Pliers       | at 1600 cfa per | 64,000 cfa  |
| k. | 20 Levels       | at 3300 cfa per | 66,000 cfa  |
| l. | 150 Tie Wire    | at 301 cfa per  | 45,150 cfa  |
| m. | 150 Hardhats    | at 1000 cfa per | 150,000 cfa |

Total: 1,154,600 cfa or at C.R. \$ 4915

|    |  |                                     |
|----|--|-------------------------------------|
| 3. | Pulleys purchased U.S.   |                                     |
| a. | 100 Steel Shell Pulleys @ \$12.50  | \$1650.00                           |
| 4. | Hand tools purchased in Lagos  |                                     |
| a. | 30 Claw Hammers @ \$2.60   | 78.00                               |
| b. | 30 Hack Saw Frames @ \$1.25  | 37.50                               |
|    | Total: 27,143 cfa or at C.R. \$115.50  |                                     |
| 5. | Gas, Oil and Repair Parts for Peace Corps Trucks   |                                     |
| a. | Gas: 16,000 liters @ 75 cfa  | 1,205,550 cfa                       |
| b. | Oil: 800 liters @ 125 cfa  | 98,700 cfa                          |
| c. | Repair parts   | 1,506,350 cfa                       |
|    | Total: 2,810,600 cfa or at C.R. \$11,960   |                                     |
| 6. | Repair 25 Steel Molds @ 12,000 cfa   | 300,000 cfa                         |
|    | Total: 300,000 cfa or at C.R. \$1275   |                                     |
| 7. | Rental of 2 Storage Facilities at 60,000/mo.   | 720,000 cfa                         |
|    | Total: 720,000 cfa or at C.R. \$3060   |                                     |
| 8. | Vehicles purchased locally   |                                     |
| a. | 1 Peugeot 404 Pick-up Truck  | 876,000 cfa                         |
| b. | 10 Charrettes @ 28,000 cfa   | 280,000 cfa                         |
|    | Total: 1,156,000 cfa or C.R. \$4920  |                                     |
| 9. | Miscellaneous Purchase Fund  |                                     |
|    | We propose this fund to insure for funding of any additional purchases that may be necessary throughout the year. The Program Coordinator will regulate the fund with signing approval by the local AID Officer. |                                     |
|    | Total: 509,950 cfa or C.R. \$2169.50   |                                     |
|    | Itemized Budget Total for F.Y. 1975  | 23,500,000 cfa or<br>C.F. \$100,000 |
|    | Budget for F.Y. 1976   | 11,750.00 cfa or<br>C.F. \$50,000   |
|    | Total budget request PC/HER Wells Program<br>1974-1976   | 32,250,000 cfa or<br>C.R. \$150,000 |

## Non-AID Inputs

As outlined above, Peace Corps will provide fourteen Volunteers to work at the village level, as well as the Wells Program Coordinator to work at H.E.R. in Ouagadougou. When necessary, Peace Corps will make available light trucks to the Volunteers. H.E.R. will provide housing for the Volunteers and vehicles for in-country transport of materials. The Sous-Prefets will pay the masons' salaries, and villagers are responsible for the manpower and supplies of certain materials, such as sand and gravel.

## Reporting Requirements

The Program Coordinator will submit to AID a quarterly report describing the progress of the program and detailing the situation of each Volunteer, including the number of depth of wells under construction and the amount of water in them.

In addition, as part of the Upper Voltan Government's Monthly Financial Report for all of the AID-financed drought recovery projects, and the financial status of the Wells Program will be included. This report will include total expenditures to date, as well as the expenditures for each line item of the budget. Local currency (CFA) expenditures will be expressed both in CFA and in U.S. dollar equivalents. This report will be prepared for the Government of Upper Volta by the Banque Nationale de Developpement.

## End-Use Accountability

After June 1978, the Government of Upper Volta and the Peace Corps are no longer responsible for equipment and other items made available under the grant. The additional two years after term allow for the continued local use of equipment and its depreciation.

## Modification of the Activity

If necessary, to be accomplished by the issuance of additional implementation letters.

## 2. CONTRACT, TOGO

Projets techniques/sociaux  
Region Atakpamé/Akposso  
Eglise Evangélique du Togo  
B.P. 79  
Atakpamé

### Contrat de Gre a Gre Projet de Puits

Avant l'arrivée de l'équipe essayant de faire une installation d'un puits la population du village ou groupe de \_\_\_\_\_ accepte les conditions suivantes:

#### 1. Conditions de Travail

La population du village est responsable de fournir huit (8) hommes chaque jour de travail et jusqu'à ce que le puits soit réalisé.

a. Ces hommes peuvent être engagés par le village ou ils formeront une équipe du villageois.

l'âge minimum pour les ouvriers - 18 ans

l'âge maximum pour les ouvriers - 45 ans

b. Les heures du travail sont les suivantes:

|          | Matinée  | Après-Midi |
|----------|----------|------------|
| Lundi    | 7H à 12H | 14H à 17H  |
| Mardi    | "        | "          |
| Mercredi | "        | "          |
| Jeudi    | "        | "          |
| Vendredi | "        | "          |
| Samedi   |          |            |
| Dimanche | repos    | repos      |

c. Le directeur du projet avec l'équipe de puits n'acceptent pas les excuses du village si son équipe manque un jour de travail sauf les jours fériés nationaux. Malgré les funérailles, mariages, fêtes locales etc., le village est demandé de fournir une équipe de travail chaque jour. Autrement dit, ce n'est pas toute la population qui est affectée par chaque évènement dans le village.

#### II Conditions de Logement pour l'équipe de Puits

1. Le village doit fournir:

Une chambre pour chacun des deux représentants d'équipe de puits avec un lit - une table - deux chaises - une lanterne à pétrole, etc.

2. Le village doit fournir la nourriture trois fois par jour pour les deux représentants ci-haut mentionnés. Les heures de repas sont les suivantes:

III. Conditions de Paiement

Le village ou groupe comprend que leur participation minimum pour l'installation d'une pompe est de \_\_\_\_\_ francs au total.

- a. Avant le commencement du travail le village ou groupe payera \_\_\_\_\_ frs. CFA.
- b. Si l'équipe a trouvé l'eau en quantité suffisante le groupe/village payera \_\_\_\_\_ frs. CFA avant de faire l'installation.
- c. Ces sommes seront confiées au directeur du Projets des Puits (actuellement J. Winter) qui donnera un reçu.
- d. Si l'installation demande les dépenses extraordinaires le village ou groupe doit supporter 2/3 des dépenses supplémentaires.
- e. Si le projet ne réussit pas, la somme déposée sera entièrement remboursée au village ou groupe.

A Noter

Si jamais l'une de ces conditions mentionnées ci-dessus n'est pas remplie, le chef d'équipe de puits pour le directeur du projet a l'autorité de rembourser la somme de \_\_\_\_\_ frs. CFA au village et de laisser le chantier.

Declaration par le Garant du Village

J'accepte la responsabilité au nom de ce village/groupe de satisfaire les conditions de ce contrat, je comprends que l'équipe de puits ne peut pas promettre que ce projet réussira dans mon village.

Date \_\_\_\_\_ 19 \_\_\_\_\_

\_\_\_\_\_  
Signature du garant

\_\_\_\_\_  
Signature chef d'équipe de puits

Date de l'installation de ce puits \_\_\_\_\_ 19 \_\_\_\_\_

Typical Activity Report for Well Site

Fiche de Puits  
ou Forage  
No. \_\_\_\_\_

Nom du Village \_\_\_\_\_ Puits No. \_\_\_\_\_

Région \_\_\_\_\_ Circons. \_\_\_\_\_

Date Terminé \_\_\_\_\_

Responsable \_\_\_\_\_

Exécuté par \_\_\_\_\_

Caractéristiques Nappe

Profondeur \_\_\_\_\_ (mois \_\_\_\_\_)

Débit approx. \_\_\_\_\_ l./h. (mois \_\_\_\_\_)

Caractéristiques Installation

Coupe Stratigraphique

Pompe -

Dalle -

Coffrage -

espèce -

longuer -

Trinlage -

Cylindre à piston -

Crépine -

Filtre -

Profondeur -

Remarques \_\_\_\_\_

Observations Subséquentes:

Observée par \_\_\_\_\_

Date \_\_\_\_\_

Remarques \_\_\_\_\_





**PART V**

**LARGE DIAMETER WELLS**

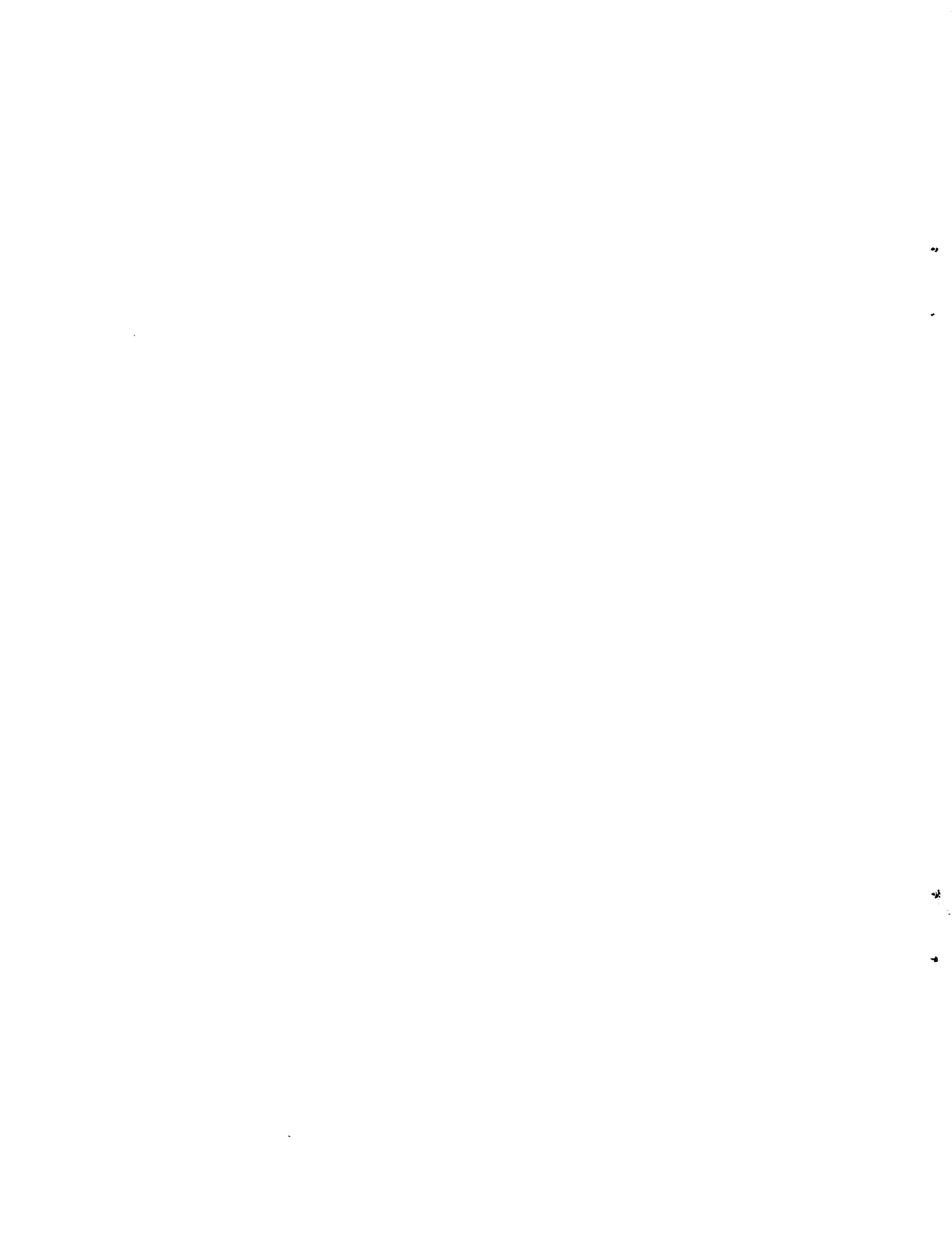

# 1. TOGO, CEMENTING WITH A MOLD

## 1. PCV Dunham Rowley, 1970

### CONTENTS

- I. Introduction
  - A. Goals
  - B. Wells Program
  - C. General Information
  
- II. Organization of Well Teams
  - A. Structure
  - B. Funding
  - C. Additional Information
  
- III. Technical Information
  - A. Tools
  - B. Choosing the Site
  - C. Construction of Well
    - 1. Placement of re-rod
    - 2. Leveling the mold
    - 3. Mixing Platform
    - 4. Mixing
    - 5. Pouring
    - 6. Curing
    - 7. Important Points
    - 8. Supports
  - D. Second Day
  - E. Lowering the Mold
  - F. Some Points About Molds
  - G. The Water Table
  - H. Superstructure
  - I. Conclusion

### C. General Information:

1. The diameter of the well is 125 cm.
2. The thickness of the cement wall is 7 cm.
3. The height of the mold is 1 meter.
4. The mold is a circular sheet of metal 2 mm. thick which is bolted together at the extremities. The mold is reinforced for rigidity by two wooden collars.

## II. ORGANIZATION OF WELL TEAMS:

### A. Structure

In the Togo Wells Program the organization of well teams is the responsibility of the Volunteer in the particular village. Usually the Volunteer establishes contact with a young man in the village who speaks French well enough to communicate with the elders. In this way he can suggest that they form teams to work on alternate days. This is especially important during the rainy season when it is possible to work if the village is organized and willing.

The Volunteer is the crucial person in the whole structure because it is he who must animate the villagers, who must order materials, and who threatens people to work by relying on the traditional political system, i.e. chefs de canton etc. The process whereby the system is kept going is by having relations with the village chef, maintaining good relations with the chefs de la circonscription, maintaining good relations with the SORAD in order to always get needed materials. So, in many cases, it is the Volunteer who keeps the project going by keeping lines of communication going with the village, the traditional administration.

The logistics of the program are coordinated by the Volunteer in Lome by the use of a truck in outlying areas.

### B. Funding

The funding of the Togo Wells program is done on two fronts: the Togolese government and the United States government. Under the Ministry of Rural Economy it was agreed to create a budget d'investissment which is controlled by the SORAD, for the buying of materials such as sand, gravel, cement, re-rod, and any mason's salaries.

CONSTRUCTION OF LARGE BORE WELLS IN SEDEMENTARY SOILS  
CONSISTING OF LATERITE AND ASSORTED CLAYS MIXED  
WITH SAND IN THE MARITIME REGION OF TOGO

- I. INTRODUCTION: This report provides basic knowledge for the construction of large bore wells in Southern Togo. Revision has been made according to suggestions offered at the Upper Volta Regional Wells Conference held in September, 1970
- A. Goals of the Togo Wells Program: Besides the obvious ~~objective of increasing water supply on the village level, we should concentræte on the following:~~
1. Follow-up programs for village sanitation, possibly involving Service d'Assainissement.
  2. Increasing cooperation with local administrations, such as the chefs cir, the chefs des cantons, the SORAD, and Assainissement.
  3. Training the masons in concrete methods until they are competent.
  4. Placing pumps and covering a limited number of wells.
- B. The Wells Program: The Togo Wells Program was created by John Mullenax a former Peace Corps Volunteer, in 1963 by a written agreement between the American Embassy and the Ministry of Rural Economy. Under this accord, the Embassy supplies necessary funds to buy and maintain equipment while the SORAD, the development agency in the Ministry, funds the buying of materials, transport, and masons' salaries. In this way Peace Corps is directly integrated with the Togolese who also play an important role in site choice.

Deciding which villages receive wells is based on demands sent from villages either to the Circumscription or to the SORAD.

Agriculture agents in the SORAD may also suggest villages, either for political reasons or because of real need. Another factor which affects selection is geology. Some areas in the Maritime Region yield salty water, where the water table is too deep, or where a layer of rock prevents usage of our method.

### III. TECHNICAL INFORMATION

All such tools, as the mold and the wooden braces, are made in Lome by local craftsmen and carpenters.

Transport tools, materials and mason's pay are difficult to estimate on a cost per meter basis because of inflation.

A. Tools: The standard tools necessary for our well program include:

1. 1 meter mold (1 m. by 2m. by 1.25 m. in diameter)
2. 2 wooden braces to support the mold
3. 1 large pulley
4. 1 small pulley
5. 2 ropes--small (20 mm. and 25 mm.)
6. 2 rubber buckets
7. 2 shovels
8. 1 mason's trowel
9. 1 pick
10. 2 open wrenches (17 by 19)
11. Wire brush for cleaning molds
12. 1 level
13. Wooden scraper to scrape walls for correct thickness of cement
14. Several nuts and bolts
15. Old engine oil to be used to oil the mold
16. A two meter rule (double meter)
17. A tool, either a chisel or "couple boulon," for cutting re-rod
18. A hard hat or safety helmet

In addition, a special compliment of tools is employed, consisting of:

1. Heavy winch for "busing"
2. Bailing barrell for working in the water table
3. Mining bar (barre a mine) for breaking compact formations
4. 1/2 meter mold for sandy loose strata
5. A buse mold
6. Exterior mold to make provisional margelle

Two men should then descend into the hole to receive the two wooden braces. These are wedged into the mold, then bolted together. They are placed at 33 cm. intervals. After this

On the other hand, the U.S. Government gives by way of a "Self Help" fund necessary money to buy equipment such as molds and ropes etc. In 1969 a fund was created for about \$8000.00 for this purpose. It should be added that when Togo is incapable of supplying materials at crucial times, money from this fund can be used to keep the program going. All that is needed is the approval from the Peace Corps Director on the "bons de command."

### C. Problems in Well Digging

1. cave-in in the middle of one of our wells
2. gas encountered because of cave-in
3. attaining a deep enough water reserve in the water table.

This particular cave-in took place at a depth of about 30 meters where in this well the superficial water table builds up pressure against the cement casing in a loose, sandy, fluid strata. With enough water drainage through the wall, the sand also drained causing successively larger cavities which kept caving in on each other. When the cave-in behind the casing was too great for the cement to hold it, three one meter pourings displaced in the middle of the well, allowing the sand and water to fill in the well freely.

During the dry season we have been trying to reconstruct the broken wall by filling in with laterite behind cement blocks. Then with a 1/2 meter mold X 125 cm we poured normally using more re-rod and pouring a thicker wall of cement. At this time we also experienced the occurrence of a sulfuric type of gas. With the use of a forge pump and tubing we were able to work safely. Work now on the well continues normally.

Another problem is not being able to penetrate our water table in some cases. At first when water is reached emptying the well of water to pursue further digging is a problem, first because of the flow of water into the well, and second the depth of well in some cases prohibits rapid evacuation. The average depth of our wells is about 45 meters. In this way only a meter or so of water may accumulate in the bottom of our wells, and this may fluctuate according to the season.

From the health point of view all of our wells are unsanitary and may be considered contaminated. This is simply due to a lack of pumps and governmental organization to maintain those pumps. In terms of water supply a cement well will stay intact longer with reduced possibility of cave-ins, especially at the water bearing levels.



is accomplished, the mold is leveled. This is most important as it is done by placing the level on the top rim of the mold, NOT on the wooden braces (as has been done by certain masons). In the proceeding meters, when this leveling process is done, make certain that the rim is clean.

3. Mixing Platform: After the mold is leveled, the cement mixture can be prepared. Actually, a platform (parterre) should be made next to the well for mixing the aggregates, prior to pouring a half sack of cement, some sand and gravel and spreading the mixture out on a cleared firm surface.

4. The Mixture: The proportions for the concrete mixture used in the Togo Wells Program are one part cement, two parts sand, three parts gravel. One 50 kg. sack of cement is equal to approximately three rubber buckets; thus, for each sack mix, six buckets of sand and nine buckets of gravel. Usually two sacks of cement are needed for each meter; thus it is best to make two separate batches.

All the dry ingredients should be mixed thoroughly before the water is added. Then, except while constructing the first three or four meters, divide the dry materials (mixed) into two piles and add water, a few liters at a time, to one of the piles and mix until the water and dry materials are completely combined. After most of this mixture has been poured in the mold, begin adding water to the second pole of dry materials. The reason for dividing the mixtures like this and for adding water to the second only after the first is gone, is that once water and cement have combined, they begin the chemical "glueing action" and if this action is allowed to continue for too long a time before the mixture is placed in the mold, the quality of the finished concrete is considerably decreased.

5. Pouring: Concrete is poured directly into the space between the mold and the sides of the hole with the aid of a shovel or piece of tole. A few buckets should be poured on one side and then the opposite side, continuing around the mold in this manner. This is done to prevent concrete from piling up on one side, thereby causing the mold to shift. Periodically the mold should be tapped with a hammer to allow proper settling of the concrete around the re-rod caging and to eliminate air bubbles.

When the mold is filled to 50 cm., the exterior mold is positioned for the provisional margelle. This mold is made from sheets of tole, cut and nailed together to a height of 50 cm. One can use whatever is available to support this, either palm branches or odd pieces of re-rod. Try to pour concrete all the way to the top of the margelle mold, because the higher the margelle the less chance of animals or children falling into the well.

6. Curing: It is very important that concrete be properly cured--kept wet for several days. Concrete which has been cured for 14 days is approximately twice as strong as concrete cured for three days. It is sometimes difficult to keep the concrete wet, due to lack of water, but every effort should be made to do so. The margelle should be covered with burlap, sand, grass, or some other water-holding material and kept wet for several days.

7. Incidental But Important Points: Mixing concrete is a relatively simple operation, but it is important to remember certain factors:

- a. Keep all foreign matter (grass, leaves, twigs, etc.) out of the mixture.
- b. Do not add too much water--some masons and villagers continually put an excess of water in the mixture.
- c. Do not over-mix the concrete.
- d. Above all insist upon the correct proportion of dry materials--one part cement, two parts sand, three parts gravel.

8. Supports: The first day about three hours after the cement has been poured, the wooden braces can be removed and digging can start arranging the chantier. Two forked logs 3 or 3 1/2 meters long with a minimum thickness of 20 cm. are posed on each side of the well to a depth of 1 meter to support a transverse log. No matter how scarce the wood is in a particular area, the villagers always seem to find the necessary wood if they are really animated in digging their well. On the cross piece, the large and small pullies are attached tightly with N 6 re-rod, so they won't slip around. A fourth piece of log should be dug into the ground opposite the pullies, back about four meters from the well. This is for wrapping the cord around when descending heavy weights. At this time all traffic in and out of the well, be it human or otherwise, goes via rope and pulley. It becomes rather crucial to you, if you are human, that it be strong (rope, pulley, and pulley support).

D. The Second Day

Usually the second day is given to digging and pouring the second meter. As in the digging of the initial hole, most masons prefer to dig a rough hole the full 108 cm. depth and then come back to widen the hole to the full diameter

of 139 cm. What becomes important in this widening process is getting the hole straight and vertical and the diameter a uniform 139 cm. When the hole is too large, it takes an unnecessarily large amount of concrete to fill the space between the hole and the cuvelage mold. When the hole is too small, one runs the risk of making the walls of the cuvelage too thin, and in extreme cases, having the mold touch the edge of the hole at some point, leaving a hole in the cuvelage.

After the mason finishes off the hole, the re-rod is placed. Remember to sink the vertical 6 mm re-rod twenty centimeters into the ground at the bottom of the hole. The exposed re-rods from the first meter are hooked and attached to the re-rod for the second meter with wire in three places leaving between 10 cm. and 15 cm. between the hooked ends. The horizontals are placed in the same fashion as the first meter. The bottom is again leveled and blocks placed on the floor of the hole, as was done for the first meter. The mold is then lowered.

#### E. Lowering the Mold

A rope with four hooks is attached to the mold, the rope being supported by the pulley and tightly held. Two people are now needed in the well to carry out this process. The mason should first tap around the mold. He then removes the bolts. Next he should tap on either side of the joint where the mold is bolted together. One side of the joint will begin to come loose and tapping should then continue of the side which remains against the wall. The second person in the well should be exerting his weight against the side being loosened, so that when the mold springs off, it will have some guidance. Eventually the mold will come loose, and it should then be lowered. Since the mold is one meter high and the hole dug is 108 cm. high there will be a 8 cm gap between the cuvelage last poured and the top of the mold in the hole. The concrete for this next cuvelage will be poured through the gap which will be closed with a stiff mixture of concrete.

Once the mold is descended, it is re-bolted and centered after the wooden braces have been placed. When centering the mold, one should be certain that the outside edge of the mold falls directly below the inside edge of the preceding cuvelage. Then the mold itself should be leveled with a level. However, the process of leveling the mold may place it out of line with the preceding cuvelage; thus, this becomes a process of juggling the two measurements until the mold is both leveled and centered. When this is done, the concrete is mixed and poured, the joint sealed between old and new cuvelage, but with spaces left above the four hook holes in the mold, so that it may be lowered in this fashion for the next meter.

F. Some Points About Molds

1. When tapping, do not tap too hard; this leaves dents in the mold.
2. The mold should always have a thin layer of oil spread on it.

This not only makes it best for storage, but makes it easier to keep clean and much easier to remove when the concrete has set. Old engine oil does nicely or any cooking oil found in the village.

3. The mold should be cleaned and oiled every four meters.

G. The Water Table

Pouring the cuvelage should stop just before the water table. Poured meters into the water table result in cave-ins of sand and silt behind the cement casing. This puts too much downward vertical weight on the well casing. With enough cave-in and erosion, the well at the bottom will fall in or simply drop down causing all sorts of problems. Thus, the poured cuvelage should be well anchored and strengthened above the water table. To attain the water table, buses are lowered and dug in place. (Buses are pre-fabricated cuvelage or cement rings 50 cm. high.) This work is most suitably done during the dry season because the water table presumably be at its lowest level.

By means of a well-anchored winch and strong supports, four 50 cm. pre-fabricated buses are stacked up and bolted together at the bottom of the well. To keep the buses straight while digging them in, gravel is placed to a height of 1 or 2 meters between the well and the buses. After digging begins, another two buses can be placed on the four already in the well to add weight in sinking the buses. Sinking continues until the water can no longer be drawn fast enough to dig more. Hopefully with the use of a bailing barrel and constant bailing of the well in general a reservoir of 1.5 or 2 meters can be attained. Finally, a layer of gravel is placed on the bottom of the well to stabilize silt, sand and the buses, while also acting as a filter. One meter of buses should be left above the gravel behind the buses.

## H. The Superstructure

Our superstructure have been grandiose affairs in the past, with a wide cement apron encircling the well. The apron serves to drain spilled water and keep the well area free of mud and other contaminating agent. The making of the margelle super-structure is really left to the Volunteer and mason, but two factors should be kept in mind. 1) allow for proper drainage of the well area, 2) make the margelle high enough (about 65 cm. or 75 cm.) to prevent animals and other living things from falling in.

## I. Conclusion

Although PCVs we are chefs of a Service, whether we like it or not. There are times when our authority as such should and must be pushed or the program falls from the Service, of Togo, and of Peace Corps into a vulnerable and non-priority position. Especially is this so in the presence of the masons and villagers; signs of weak-heartedness should rarely, if ever, be obvious. Masons want a chef who knows that he is doing, who knows and cares about his equipment and about the work which is going on. There is a friendly but firm relationship which is appropriate between a chef of a Service and the mason/labourers. A certain distance must be kept to be effective, or you will be taken advantage of.

Nearly the same relationship should exist with the other services, but with a deeper and continuing search for cooperation. It all really depends on where you are going to draw the line in working for and with the people. Either you fulfill your role or compromise the knowledge you were sent here to use and the Service you were invited to support and strengthen.

# TOGO



*LEVELING BLOCKS upon which the mold will rest for the second meter.*

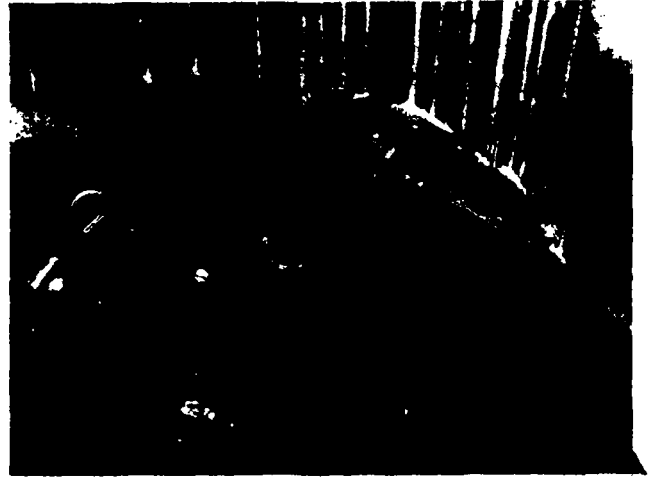

*PLACING of the re-rod begins*



*FINAL RE-ROD assembly before mold is dropped into place*



*BOLTING and FITTING the mold for the second meter*



*CENTERING the mold so that it follows the one on top*



*POURING cement through the 8cm gap between meters*



*MOLD for the CUTTING RING to be placed under the buses*



*50 cm BUSE MOLD showing triangle and re-rod placement*



*LOCKING extremity joints of 50 cm buse mold. The leaves swings out but are bolted to the table*



*A 50 cm buse mold in finished form*



*Close up of two 50 cm buses bolted together*



*Two 50 cm buses bolted together*

## 2. TOGO-DIG A METER, POUR A METER, VOGAN REGION PCV John Toney, 1974

A. The overriding reason for the use of this type of well construction in Vogan is the large amount of sedimentary soil found here. Also, the average depth of the water table is near twenty-five meters which necessitates strong walls to prevent the collapse of the well before water is reached.

B. Normal tools used in any particular well site:

1. One mason's trowel
2. Two open wrenches, 17 x 19 mm.
3. One large pulley
4. One meter mold (1.25 m. wide, 1 m. tall, 2 mm. thick)
5. Two wooden bracks for mold interior
6. Two rubber buckets
7. One long rope of 21 mm. thickness
8. Oil to lubricate the mold
9. One level
10. One folding ruler
11. One heavy duty wire cutter for cutting fer-rond
12. One or more hard hats
13. One buse old (external mold 1 m. high, diam. 1 m., 50; interval 1 cm. high, 80 cm. diameter)
14. Nuts and bolts (17 cm. or 19 cm.)
15. Winch for placing buses
16.  $\frac{1}{2}$  cm. mold for margelle

C. Technique

The choice of well site is generally left up to the villagers, as it is thought they can best decide the location most suited to their particular needs. Often, they best know where water will be found because they might have knowledge of where an old well was located that did yield water once but has been abandoned or has collapsed. If there don't seem to be any problems with the mason and workers over the site choice, work begins by clearing the surface of the land around the proposed well site. A stake is placed in the ground mid-way across the proposed 145 cm. diameter. The workers dig 50 cm. down and after the work is okayed by the volunteer, the full length 1 m. mold is placed in the hole after re-rod or set. The 50 cm. above the ground provides a handy margelle which matched with a demi-meter mold on top. There should be 10 cm. distance between outer demi-mold and inner mold.



However, before the molds are placed in inner mold, the re-rod skeleton must be built to reinforce the concrete. Again, in the Vogan region, the soil is generally sandy and loose so that heavy re-rod use is urged, at least for the first few meters (generally 15 ft.) until, if at all, clay soil is reached. Here the amount of re-rod can be diminished to no less than 8 vertical and 3 horizontal.

I generally use 12 vertical pieces cut to 130 cm. and placed equidistance from one another along the circumference of the well wall about six centimeters from the actual dirt wall. We then take 4 horizontal pieces of a length approximately 450 cm. and place these at +25 cm. distances from one another and attach them to the vertical pieces by thin piece of wire.

When the re-rod is satisfactorily placed, the meter length mold is placed in the hole and carefully placed so that the distance from the mold to the wall is the same all about the circumference. The mold ought to be closed by the bolts before you put it in the hole. The mold can be leveled by placing it on blocks of wood that rest on the bottom of the hole. By adjusting these pieces of wood, the level is best adjusted. I personally find these pieces of wood a pain, so I chance the level by digging or adding earth where necessary. In any case, it is very important that the mold be well balanced to ensure even spacing between each meter.

Then the two wooden braces should be placed on the mold's interior about 30 cm. heights. (Simple mathematics - 2 braces will give 3 different mold areas and the best division of these on a mold of one meter height is 33 cm., 33 cm., 33 cm., to give 99 cm.) Check again after they're placed to see if you haven't botched up the leveling of the mold. If so, go back and start again. And now, if all goes well, and it's not raining, you can begin to mix the cement.

But first I forgot to tell you that your 130 cm. vertical pieces are supposed to be pushed into the ground 30 cm. so that the re-rod for the next meter can be attached. O.K.?

Now cement. We all know our own special formulas for proportions, and I really can't say which is best; but here's the house recipe: 1 pkg. cement (50 kg.) = approx. 3 buckets-full 1.5 cement and 9 seaux de sable + 12 gravier for each meter.

Better safe than sorry, eh? Mix, Mix, Mix all these ingredients together fully before adding any H<sub>2</sub>O. When fully mixed, divide into 2 separate piles. Slowly, ever so slowly, add H<sub>2</sub>O to one pile where mixing. Don't make it too soupy or thick, neither works well. It's difficult to say what are the right proportions. I suppose only by experience does one see. I've found that many villagers like to drown the mixture as it is easier to turn and mellange with plenty of water. Watch 'em!

As soon as most of one pile is mixed, start filling buckets up and sending them over the side, to fill up the area between earth wall and mold form. Pour a little here, a little there, all around the form so that the cement has roughly the same height all around as it uses. By this time, we usually call it a day.

Aside: Actually, I consider anyone lucky who can get their vil-lages to both dig a meter 10 and pour the mold in the same day. It usually works out that they dig one day, pour the next. Barring those normal twice weekly family deaths, illnesses, funerals, holidays, or Sunday excuses that keep people from work, 4 meters a week is above average.

Next morning, get up bright and early, say your morning prayers, drink your Ovaltine, and return to the work site. Remove the molds, check the walls and start digging. Dig to a depth of one meter 10 cm. with a diameter of 140 cm. Remember, the wall ought to be about 20 cm. thick all around. Descend into the hold frequently to measure the depth of diameter because if it is too wide, too much concrete will be used up.

When all is done, place your re-rod as before, but sink those verticals only 15 cm. now and bind the upper 15 cm. to the protruding ones from the first buse. I prefer placing them side by side and wrapping them together with thin wire. Lower mold level. Place wood level. Mix cement. Fill behind mold with cement. Please make sure that the mold is exactly in line in the edge of cement buse wall above it. Fill the 10 cm. space between the old mold and the new with a nice mixture of mortar (cement and sand) and 2 hours after the last of the mold cement has been poured. When water level is reached, STOP! Remember you may be facing a rainy season initiated nape. (Perhaps you ought to do this particular well during the dry season?) But if you've got the real thing, a continuous nape, start fabricating your buses above ground, following the basic procedures of re-rod use and cement proportions as previously described. Be sure that molds are well oiled to prevent sticking. Leave cement in the mold at least 24 hours and, once fabricated, do not use for a minimum of 14 days to aid the curing process. Have water splashed over these molds at least once a day by the villagers during this curing time. These buses will have a height of one meter, inner diameter of 80 cm., outer diameter of 100 cm.

With the aid of a heavy duty winch, the buses should be lowered into the hole, with two or three being cemented together at a time in the hole. No one should be in the well when buses are being lowered!

When one has a few buses well situated in the bottom, dredge all the water out and continue digging. Gradually, as the hole deepens, the buses will sink. A point will eventually be reached where there is too much of a return flow of water into the hole to allow it to be drained to continue digging. This means that

there probably is a minimum water depth of 2 meters.

The last step involves fabricating bricks which will rest between the last poured in place mold and the first above ground fabricated base. The idea here is to prevent buckets, calabashes, etc. from getting wedged into this small area.

# 3. NIGER, A WELL DUG WELL

A GUIDE TO WELL CONSTRUCTION  
NIGER

## Stephen R. Isom, 1971

### INTRODUCTION

This report is meant as a guide to Volunteers working in large-bore well construction in Niger. The introduction covers the concepts of Self-Help Well Construction (Investissement Humaine), a history of Self-Help Well Construction/OFEDES, and the role of the Volunteer in the program. The main body of the report is the job description: areas of work, priority lists, dig-a-meter-pour-a-meter type of well construction, building and placing of the concrete water filters, construction specifications, equipment for masons, and safety procedures. The conclusion deals with the community development projects that can be started in collaboration with the new wells and other assorted odds and ends.

### BACKGROUND

It is estimated that there are 9,000 villages in Niger and some 18,000 wells of which only 3,419 are cement as of June, 1971. The traditional well is constructed without support and offers neither a safe nor sufficient supply of water. In addition, there is the constant danger of cave-ins during construction. The cement wells which have been constructed offer a safer method of construction which eliminated the danger of cave-ins, a more sanitary supply of water than the traditional wells which are not cased, and a more abundant and easily accessible supply of water. These wells have been financed through local administrative budgets or through foreign assistance grants. Most of the wells have been constructed through private firms at an average cost of 30,000 to 40,000 CFA per meter. \*

The first wells were constructed by the French military beginning around 1915. In 1947 the Service de l'Hydraulique was formed to construct and repair wells. This service was then

incorporated into Travaux Publique in 1959. During this time the financing of wells was furnished by FAC and FEDOM until 1964. Beginning in September, 1964, OFEDES (Office Des Eaux du Sous-Sol) was formed to handle both large-bore and small-bore wells. The first director was Mahamadou Moussa who was killed in an auto accident in 1966. The present director, Gabriel Mayaki, started in January, 1967. Since 1961, most of the well construction has been handled by private firms through financing by FED. To date they have financed three phases of well construction; 376 wells beginning in 1961, 150 wells beginning in 1967, and 516 wells in 1969.

The Niger Investissement Humaine (I.H.) program had its beginning in 1965 when a PCV responded to the request of a small village to aid them in constructing a concrete well. The village was willing to supply the "unskilled" labor and cover all costs incurred. The cost of the well constructed was considerably lower than the average cost of wells in Niger. The local officials, interested in the method used and the concept of self-help, established a pilot self-help well-construction project of ten wells with an AID technician heading the project and two Peace Corps Volunteers supervising the work.

The project succeeded in proving that wells could be constructed at a much lower cost than others being done in the country due mostly to the self-help aspect and the minimal amount of equipment used. USAID and the Government of Niger agreed to co-operate in establishing a Self-Help Village Well-Construction Project in the Arrondissements of Dogondoutchi, Birni N'Konni, and Madaoua. The Niger Government would supply the cement, the masons, the gasoline, and oil, and the maintenance of the vehicles; USAID would supply the hand tools, the vehicles, the reinforcing rod, and the molds; and Peace Corps would supply the Volunteers to supervise the construction. An AID/NEF technician was hired to serve as technical adviser. The service for the construction of Self-Help Village Wells (Investissement Humaine) was created within the framework of OFEDES, one of the five services in the Ministry of Economie Rurale.

At the end of June, 1967, when the first well was begun in the region of Dogondoutchi, there were three Peace Corps Volunteers working in the program. By the 15th of March, 1968, seven PCVs were working in the program, and a total of 38 wells were under construction or completed in the five regions: Dogondoutchi,

Birni N'Konni, Madaoua, Dosso, and Filingue. During the next digging year, October, 1968, the program had expanded to include Tessaoua. In October, 1969, the administration of I.H. was taken over completely by OFEDES without an outside technician. Each Volunteer worked directly under his departmental director and was supplied all materials through OFEDES. The Niger Government supplied the salaries for the masons, the gasoline and oil, and the maintenance of vehicles; USAID supplied the hand tools; and the U.S. Ambassador's Self-Help Fund supplied the cement and reinforcing rod. Eight PCV's were working in the program, and a total of 102 wells were under construction or completed in the five departments: Niamey, Dosso, Tahoua, Maradi, and Zinder.

In October, 1970, the I.H. program started off with eight Volunteers in six Arrondissements spread over the five departments: Filingue, Dogondoutchi, Madaoua, Tessaoua, Mayahi, and Magaria. Financing was supplied by UNICEF, the Ambassador's Self-Help Fund, and OXFAM. In accordance with the conclusions reached during the Well-Diggers Conference in July, 1970, of the need for vehicles, Peace Corps supplied one Land Rover and two Toyotas. There are 84 wells previewed for completion during the year.

#### INVESTISSEMENT HUMAINE

The concept of Investissement Humaine is one of self-Help. A village requiring a well is supplied with one trained mason, cement, reinforcing rod, molds, and all essential equipment including rope and pulley, or a hand winch. The village is responsible for supplying the necessary labor, shelter for the mason and his family, and the indigenous materials: sand, gravel, and water. Due to the minimal amount of equipment, low overhead, no profit, etc., the wells can be constructed at an average cost of less than 10,000 CFA per meter, one-fourth the cost of wells constructed by the enterprises. A second advantage of I.H. wells is the possibilities of related community development projects such as sanitation, forestation, and gardening. A third aspect is the villagers pride in "their" well and an understanding of self-help activities as an economic value that could improve their way of life.

#### THE ROLE OF THE PCV

The role of the PCV well-digger is very diverse. Primarily, the

Volunteer is a field representative for his departmental director and is directly responsible to him. He also works closely with the Sous-Prefet in establishing the list of villages to receive wells and their priorities based on need. He carries out surveys of the villages to determine the materials needed for each well, the availability of labor, sand, and gravel, and the willingness of the villagers to give maximum co-operation during construction. He helps local officials in the animation of the villages, handles all logistics involved in supplying the well sites, trains the masons in the techniques of well construction, acts as an advisor to the masons, and supervises all work done.

The secondary role of the Volunteer is to be instrumental in an unlimited number of possible development programs stemming from the finished well. These possibilities will be elaborated on in the conclusion of this report.

## JOB DESCRIPTION

### Location of Volunteers

The Arrondissements to be worked by the Volunteers are usually decided by priority lists formed by UNICEF. These lists have been determined by the availability of Animation Rurale in the Arrondissements and by well priorities listed by the Sous-Prefets of each Arrondissement. Normally there will be one or more Volunteers working in each department of OFEDES. Other financial assistance besides UNICEF such as the Ambassador's Self-Help Fund and OXFAM is given for a set amount of wells in a set Arrondissement.

### Priority Lists

Once a Volunteer has been assigned to a certain Arrondissement, he will be given a priority list of wells to be dug in that area. This list is usually compiled by the Sous-Prefet, the Deputy, and the Chefs de Cantons, the local traditional leaders of the people. Ideally these lists should be complete and accurate; however, for various reasons such as political favors, lack of sufficient knowledge of the region, or insufficient amount of interest in the program, these lists are usually not complete. Another problem is the local officials do not realize

the importance of supplying a complete list so that the program for an entire region can be planned in order to reduce the cost of transportation and time to a minimum.

Once the Volunteer has received the priority list, he should acquire all the topographical maps for his area. He can then mark all the proposed villages and check with OFEDES/Niamey for what wells will be constructed by FED. This could save some embarrassing mistakes during the year.

### Initial "Tournee" to Determine Priorities

During September, the PCV should plan to move into his Arrondissement and make his first "tournee". First cover all possible sources of information on wells including each Chef de Canton, Sous-Prefet, UNCC, and Animation Rurale. Once one has a complete list of villages needing wells, get the Sous-Prefet to participate by appointing an official guide or animation agent as representative for the Sous-Prefet on the "tournee" to check all villages.

The primary reason for this "tournee" is to determine if the requests for wells are justifiable. The information the Volunteer needs is:

- 1) Where is the existing water supply? How far from the village?
- 2) If the supply is a traditional well in the village, is the water source sufficient for the population? Does the well dry up during the year?

After seeing the well or "puisards" and the Volunteer feels there is a need for a new well, the program of I.H. should be explained to them. The representative for the Sous-Prefet can be of great assistance here. If the chief and the elders of the village agree to the program, the Volunteer needs to know how far to a gravel site, to clean sand, depth of existing well, and the size of the village which is determined by the number of tax-paying families. One question that might be added out of curiosity is the age of the existing traditional well. Some go back one hundred years. At this point, the PCV should leave the village without making any definite promises.

Once the well-digger has visited all the villages he is able to make a valid priority list. Locate all the potential sites on



the topo. Map and chart out a campaign of well construction with the Sous-Prefet. The villages should be grouped according to their geographical locations due to the relative gas and time consumption. Send the results of the "tournee" to the various Chefs de Cantons whose regions have been surveyed in order to have them involved in the program from the beginning.

One is now ready for a follow-up "tournee" to be taken preferably with the Sous-Prefet, the Deputy, and/or the Chefs de Cantons. The purpose of this "tournee" is to inform each village on the priority list that if they want a well, they must collect a prodigious amount of sand and gravel before the arrival of the mason and equipment. The idea of I.H. should once again be carefully explained in detail, emphasizing the need for eight workers at the well site each day. The site for the new well should also be chosen and then cleared of all brush and loose ground. The site, for obvious reasons, should not be on top of a hill nor should it be in a low-lying area where there will be standing water during the rainy season. A small rise is preferable since this will keep the area around the well clean and free of standing water. If the villagers do not begin collecting the sand and gravel, one can question the villagers' ability to support the work and consider starting another village instead.

In the Arrondissements of Mayahi and Tessauoa, the villagers pay 30,000 CFA to have their gravel hauled to the well site in the Sous-Prefets trucks. This is due to the large distances, 25-40 km, between the gravel sites and the wells.

#### WELL CONSTRUCTION

Once sufficient time has passed for the villagers to collect sand and gravel, bring in the mason and the equipment. There should be a house ready for the mason and the well site cleared. If possible, the correct amount of re-rod and cement to finish the well and concrete filters (buses) should be supplied to the site or regional magasins when first starting the well. In the central and regional magasins, the cement should be stored in a room with little air circulation, stacked about 15 cm from the walls and raised a few cm. off the floor using logs. In the villages, it should be stored under cover and raised several cm. off the ground because of moisture and termites. At no time should large quantities of cement be left out because occasionally a freak rain or slight shower "happens".

Margelle and First Meter of Cuvelage

Drive a piece of 8 mm re-rod in the center of the cleared well site. Using a string tied to this stake, mark off the circumference of a circle 1.60 m in diameter and another of 3 m. This is for a 1.40 m well. The dimensions for a 1.80 m well are 2.0 m and 3.40 m. These are the outer limits of the walls (cuvelage) and superstructure respectively. Now the digging begins as detailed in the following diagram.

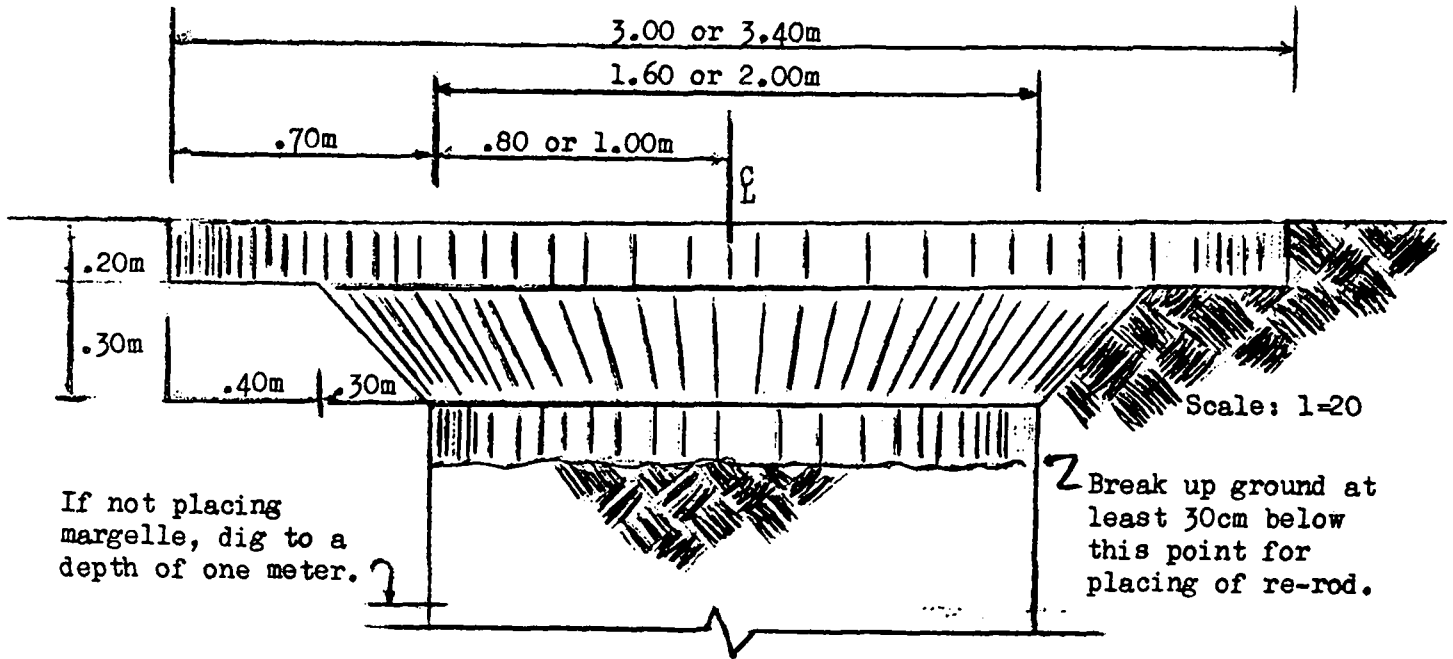

Note: By cutting a piece of re-rod the exact diameter of the hole and placing it horizontally in the hole, one can be sure of the diameter being uniform.

Note: Make sure the ground around the well is fairly horizontal or the superstructure will not be of a uniform depth.

Once the initial hole is dug, the mason can start cutting the re-rod for the edge (margelle) and superstructure as detailed in the following diagram.

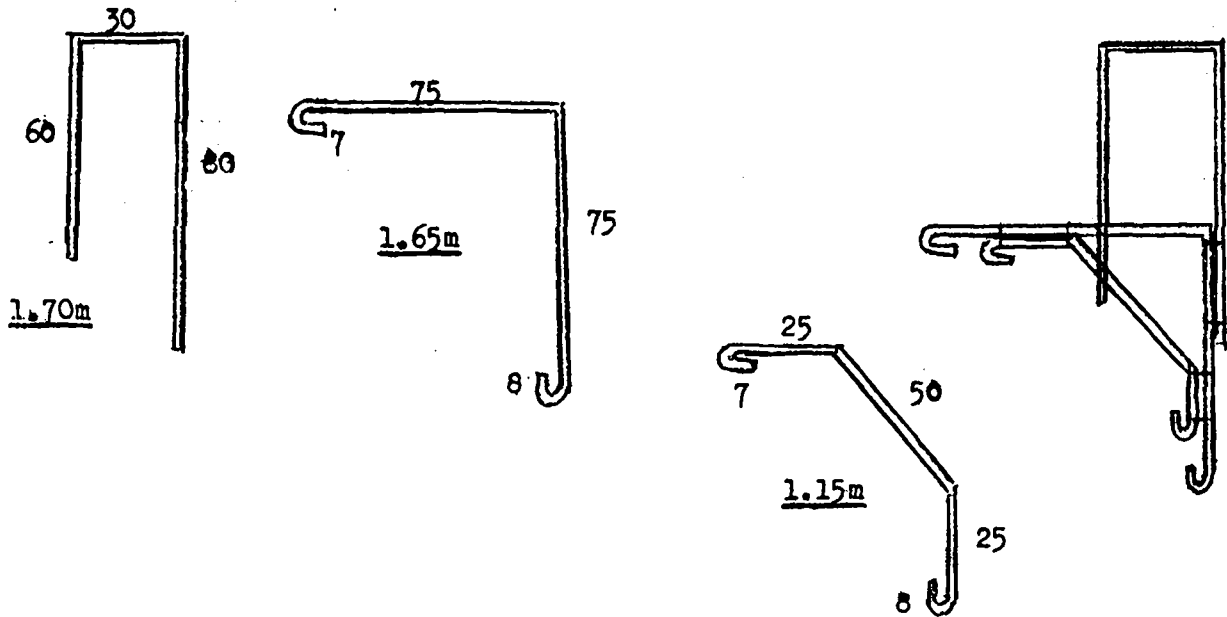

Number of Re-rod Vertical

Scale: 1=20

1.80 Well:

1.40 Well:

26 pieces using 8 mm re-rod  
40 pieces using 6 mm re-rod

22 pieces using 8 mm re-rod  
26 pieces using 6 mm re-rod

Note: If one is not going to construct the margelle until after the well is finished, leave off the U shaped piece of re-rod and add 50 cm to the lower leg of the right angle piece.

Note: The dimensions for the reinforcing rod is the same whether the well is 1.80 or 1.40 m in diameter. The number of pieces used is all that changes.

Each of these pieces can be made at the site using a chisel, hammer, and a hook-wrench (griffe). After the re-rod has been cut to the specified lengths, bend the steel using a log with

nails pounded in to hold the steel as the stationary piece and the griffe to do the bending. The reinforcing unit can then be prefabricated using bailing wire (fil de fer) to attach the pieces as shown. Next the reinforcing units are placed in the well equidistant apart and 5 cm from the vertical walls. The end of the unit should be placed 30 cm in the ground which allows for an overlap with the next meter. 6 mm re-rod is then wired horizontally 15 cm apart in a spiral fashion. This should also continue into the ground. Each 6 mm piece should have a hook (crochet) at each end and should overlap the previous piece by 30 cm. Mistakes in the diameter of the re-rod can be avoided by passing a 6.0 m piece of 6 mm re-rod for a 1.80 well or a 4.70 m piece for a 1.40 well through all the margelle pieces and attaching the ends. This guarantees a diameter of 1.90 m for the re-rod in a 1.80 well and a diameter of 1.50 in a 1.40 well. See the following diagram for details.

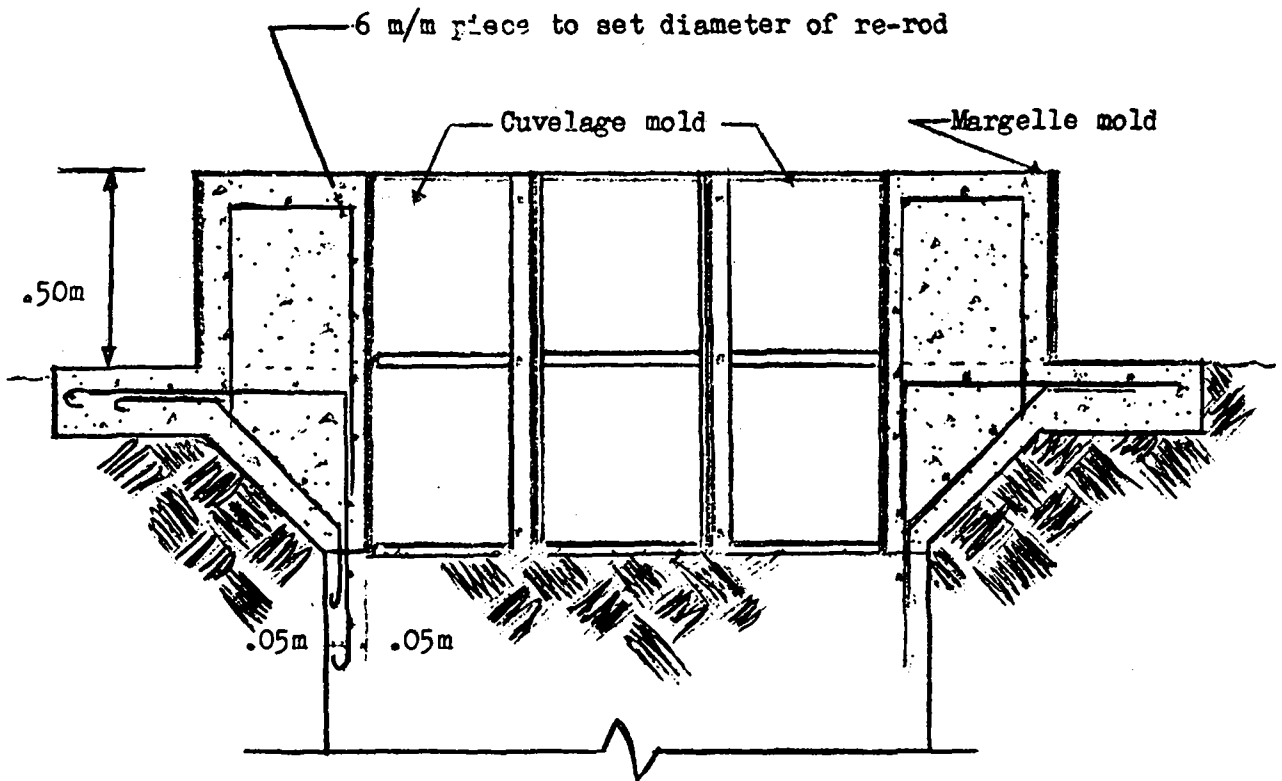

Note: The structural strength of concrete in compression is approximately 30,000 psi. In tension concrete has a strength of approx. 125 psi. For all purposes, this is zero. Reinforcing rod, on the other hand, has a strength of 48,000 psi in tension and little strength in compression. The placing of the re-rod is very important to develop its maximum efficiency in the concrete. Care should be taken to place the steel no closer than 4 cm from the outside edges of the concrete as there is little bonding strength in these outside 4 cm.

Now fill the hole until the depth is exactly 50 cm from ground level. The height of the steel should be around 90 cm inside the hole. Clean the cuvelage mold with a steel brush, oil the outside surface with old oil (huile de vidange), place the mold in the hole, bolt it together, center it, and carefully level it using a straight plank (regle) and a level. Placing small pieces of wood under the mold makes the leveling a lot easier.

### Mixing Basin

At some time after the site has been cleared and the well marked off, a concrete mixing basin is made near the well. The basin should be about two meters in diameter and excavated slightly into the ground. There should be a slight slope toward the center and also a lip around the edge so that the water is contained in the mixture. Use one sack cement, 100 liters of sand, and 200 liters of gravel to make the basin. A good 100 liter measuring can is a 200 liter drum (tonneau) cut in half with both ends open and 6 mm re-rod handles inserted into the sides. This can be done with a hammer and chisel at the well sites.

### Concrete Mixtures

Whether mixing concrete for the margelle or for the cuvelage, the mixture is always the same. To pour the margelle, the mixture will have to be duplicated four to five times. This will save in confusion for the mason and the villagers.

### Mixture for a 1.80 Well

3.5 sacks of cement @ 50 kg per sack  
500 liters of gravel  
250 liters of sand

### Mixture for a 1.40 Well

3.0 sacks of cement @ 50 kg per sack  
400 liters of gravel  
200 liters of sand

Note: The use of sand in concrete is mainly for filling the spaces between the gravel and therefore helping to bond the gravel together. The amount of sand to be used depends upon the size of the aggregates. If they are small, use less sand; if the aggregates are very large, use more sand.

Make sure the gravel has been well screened with a one cm. mesh screen (tamis) and the sand is clean. The water should also be clean and free from debris. If there is dirt in the water, allow it to settle before mixing with the cement. Other factors to watch for are foreign matter such as grass in the mixture which impares the cementing of the aggregates, too much water since the water/cement ratio determines the strength of the concrete as well as the curing process, insufficient mixing, or too much mixing.

Measure the appropriate amount of gravel and spread out uniformly in the basin and then the same for the sand on top of the gravel. Next break open 3 or 3.5 bags of cement and spread evenly over the sand. Mix this dry mixture three times, to the middle, to the sides, and then to the back of the basin away from the well. If the mixture is uniformly mixed, add water at 60 to 80 liters per mixture depending on how wet the aggregates are. One will develop a "feel" for the amount of water needed after a while but a new Volunteers should use a slump cone for testing the water-cement ratio in the mixture. A slump cone is a truncated cone twelve inches high. After the cone has been filled and packed with the concrete mixture, there should be a 3 to 4 inch slump in the mixture when the cone is removed. After the first three or four meters, mix small amounts of the concrete mixture with water at one time. After most of the first part has been placed in the mold, begin adding water to the next part. The reason for this is once water and cement have been combined, they begin the chemical "glueing action". If this action is allowed to continue for too long a time before the mixture is placed in the mold, the quality of the concrete is decreased considerably.

## Pouring the Margelle

First pat down the ground around and in the well. This will help stop the leaching of water from the concrete. Next pour the concrete between the cuvelage mold and the outer wall until the concrete has filled the superstructure. Tapping the inside of the mold with a hammer helps settle the concrete and prevents air holes from forming in the walls. Finish off the superstructure exactly 50 cm from the top of the cuvelage mold. This is essential considering the margelle mold is exactly 50 cm high. If the margelle is to be constructed after the well is finished, pour the superstructure to the top of the cuvelage mold and finish off. Allow this first section to harden until it will support a man's weight. This will take a couple of hours. Clean, oil, position, and bolt the margelle mold equidistant from the cuvelage mold, using 40 cm depending on how deformed the mold is. If the superstructure was poured correctly, the margelle mold will be level. Pour concrete between the two molds. This concrete can be augmented by placing large, clean rocks in the margelle, being careful not to touch the molds with the rocks. Tap both molds with a hammer to settle the concrete. Allow the margelle to harden sufficiently to finish off with a trowel. The margelle mold should be left in place for a few days to prevent chipping and drying.

It is very important that concrete be properly cured; that means keeping it wet. Concrete that has been cured for 14 days is approximately twice as strong as concrete cured for three days. Under ideal conditions concrete is cured for 28 days. It is sometimes difficult to keep the concrete wet due to the lack of water, but every effort should be made to do so. The margelle should be covered with burlap, sand, grass, or some other water holding material and kept wet for as long as possible.

## Dig a meter-Pour a meter

The next day after pouring the margelle, begin digging the second meter. Dig down one meter eight cm. The eight cm provides the space needed to pour the cement between the two cuvelages. Pay

special attention to digging the wall straight and to the correct diameter. Wire in the reinforcing rod 5 cm from the wall as in the first meter. The vertical pieces should be pre-cut to a length of 1.40 m in 8 mm re-rod and 1.50 m in 6 mm re-rod. Put a 7 cm bend (crochet) at each end of the vertical steel. There should always be a 30 cm overlap between the previous meter's steel and the present meter. That means sinking each meter's vertical steel 30 cm into the ground. Next attach this meter's horizontals to the previous meter's horizontals and continue to spiral at 15 cm spacing into the ground (next meter). Each vertical and horizontal intersection is to be attached with wire. Next, drop the mold. This is accomplished by loosening all the bolts and pulling out the V-shaped center piece. This is usually sufficient to allow the mold to drop as a unit. In most cases the mold has to be cleaned and oiled every third meter, but it is good practice to oil the mold again for the second meter. Bolt the mold together and level it. By aligning this meter with the above meter and leveling the mold, a well can be dug fairly straight to a depth of 40 meters. Past 40 meters a plumb should be used frequently to keep the well from "turning". It is also a good idea to check the well for straightness every ten meters or so in case there is a deformity in the mold or mason's eye. Since most of the molds are a little out-of-round, the vertical joints should line up to make a smoother cuvelage.

If the walls are exactly 10 cm thick, one mixture of concrete is sufficient to fill the mold. Fill the meter by pouring the concrete through the 8 cm joint with buckets or shovels until the meter is full. Be sure to pour the concrete on all sides of the mold since filling the mold in one spot will move the mold sideways. Pound the mold with a hammer and force in a fairly dry mixture of concrete between the two cuvelages, thus cementing the joint. After dropping the mold for the third meter, finish off the first joint with a plaster mix of sand, cement, and water. This will make a continual smooth surface in the well.

### Supports

After attaining the depth of two meters, one will find it advantageous to set up a lifting system directly over the well from which one can lower men and equipment. If a rope and pulley is being used on the well rather than a winch, the mason will set



up two vertical uprights with a heavy log crossbar resting between the forks of the vertical supports. Make sure that these uprights are firmly sunk into the ground cementing them if necessary. Also ascertain that the mason has secured the pulley to the horizontal crossbar with 6 mm re-rod in such a way that there is no slippage.

Whether using a winch or pulley system, there should be a safety rope suspended in each well. The reasons for this are obvious.

Flanges

Every ten meters a flange should be dug into the cuvelage to help strengthen the well and check against slippage. The flange is an elbow shaped cut made in the wall and placed near the center of the cuvelage. The bottom of the cut is flat, 40 cm into the wall, and the top is cut 40 cm higher than the bottom cut and angling down to meet at the deepest point of the cut. This allows for concrete to flow to all parts of the flange. Re-rod should be attached to each vertical as shown in the following diagram.

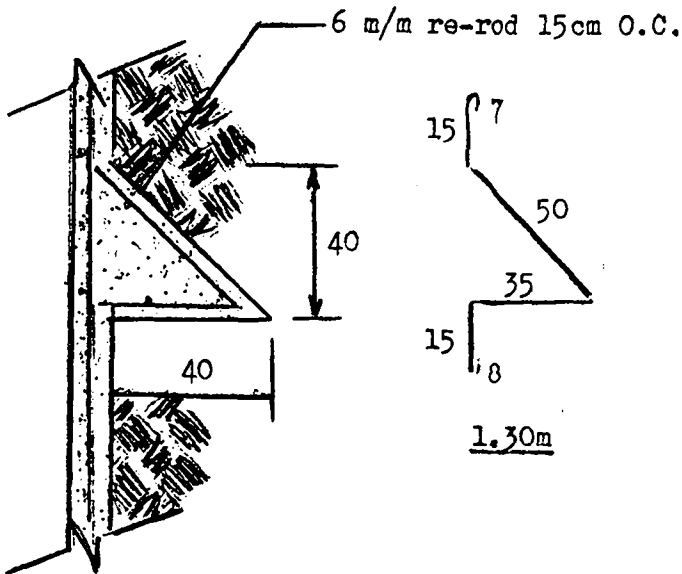

Note: It will take two mixtures of concrete to fill the flange and the cuvelage wall.

If possible a flange should be placed in the last meter before hitting water. This helps keep the soil from eroding behind the cuvelage wall due to the action of the water.

### Odds and Ends

If one is digging in loose sand, it has a tendency to fall, particularly the fine, dry variety. This can sometimes be stopped by digging down 10-15 cm and then splashing a mixture of cement and water on the walls. This dries to a thin, hard veneer in a matter of minutes. If this fails, pour 200 liters of water into the well before digging the next meter. This will saturate the sand and make it more stable. If this fails, try a 50 cm mold.

As long as sand does not fall from behind the previous cuvelage, it is not serious since the hole can be filled when pouring the concrete. If the sand falling from behind the cuvelage can not be stopped, the well will have to be abandoned for safety reasons.

It is good practice to set aside one bucket of soil from each meter dug. This way one is able to see in order all the different substrata that has been excavated.

### Supervision

Once priority lists, initial tournees, and animating villages have been accomplished, the well-digger's job is well construction. The Volunteer should be present for the construction of the margelle and the next one or two meters. During these two or three days, the PCV can both instruct the villagers in well construction (i.e., concrete mixtures, quality in curing, safety procedures, etc.) but also check the mason for faults in technique. After the completion of the first three meters, the Volunteer should visit the site every week to ten days. During each visit he is responsible for checking the following:

1. Pulley, pulley axle, rope, or winch for structural faults.
2. Number of cement and re-rod used as compared to number of meters dug.
3. Sufficient old oil and wire for two weeks work.

4. Safety procedures around well such as safety rope, number of workers on the winch or rope, tools left on the margelle, method of handling the bucket when it enters or leaves the well, use of safety helmets, and small children around the well.
5. All equipment including tools and buckets for upkeep. Make sure there is a re-rod reinforcing the bottom of each bucket.
6. Depth of well.
7. Straightness of well.
8. Spacing of steel, wall thickness, joints between molds, clean underside of previous cuvelage, and quality of cuvelage.
9. Type of substrata being excavated.
10. Watering margelle and cuvelage for the first 28 days. After 10 meters or so the walls sweat enough to keep the concrete continually wet.
11. Gravel, sand, water, and cement mixtures.
12. Progress of well. If the progress is insufficient considering the proximity of water and the type substrata being excavated, it is time to animate the villagers. It is also a good idea to inform the Sous-Prefet, Chef de Canton, and Animation Rurale of the progress in the program so they can help animate the villagers when there are problems.

Once a mason has finished a well, hopefully there is another village well animated that he can start immediately. The process is the same.

#### Meters Dug Per Month

OFEDS has set a minimum digging rate of 12 meters of cuvelage per month or a little less than 3 meters per week. If a mason falls below this average through no fault of the substrata or villagers, he should be fired. If one is digging in hard clay or rock, the work will naturally progress more slowly. This is also true for wells over 40 meters since more time is required to raise and lower the bucket. If the digging conditions are

favorable, the mason is a good mason, and the villagers are well animated, the Volunteer should expect around 20 meters per month. It has been proven during the 1970 digging season that a meter a day for a well up to 40 meters is quite feasible.

After training the villagers for the first 5 meters or so, the mason's role is usually that of a supervisor except for personally shaping the walls, placing the re-rod, dropping the mold, leveling it, and finishing the joints. Doing this once a day is not particularly tiring. The problem is to animate the villagers and mason at the start of the well to finish one meter each day while the going is easy. Once this becomes a habit, they will expect to finish the one meter each day. This also means the mason must use efficient techniques. Two buckets should be used so that there is always one going up or down in the well while the second is being filled or emptied, the re-rod should be cut in advance, and the gravel, sand, and water should be ready to mix once the mold has been set in place.

### Bonuses

In January 1971, OFEDES started paying bonuses to the masons at a rate of 200 CFA for each meter dug over 12 meters per month. This does not seem to be much of an incentive to the masons to work harder or animate the villagers to work harder. The problem seems to be the lack of a punctual financial reward at the end of each month for the month's work. This is because the figures for the month have to be sent to Niamey and then the bonus sent back with the salary for the following month. If a system could be devised for paying the masons at the end of each month for the month's work, there would be a direct cause and effect relationship. The bonus of 200 CFA is also rather small considering a mason who finishes 20 meters in a month would receive only 1600 CFA. A bonus of 300 CFA per meter over 12 meters per month seems more practical.

### "Buses"

After the mason has found water and can not dig further, pre-cast concrete rings known as "buses" are lowered into the water table. The "buses" consist of a cutting ring on the bottom (trousse coupante) and four or five concrete rings each one meter in height. These "buses" have two functions. First, they form a

cylinder that can be sunk into the water table to form a reservoir of three or four meters. Secondly, the holes in the "buses" act as filters to keep foreign matter from entering the well through the water table.

The construction of the "buses" is usually done at each well site by a special "buse man". In the future, as more "buse" molds become available, the mason at each site will probably be responsible for building the "buses".

The procedure for building the "buses" is as follows:

1. Put the base plate together ( 2 pieces).
2. Bolt the inside pieces of the mold in place (4 pieces).
3. Oil the inside mold and the base.
4. Place the re-rod, the channel pieces (etrier) for bolting the "buse" end to end (3 pieces), and the rubber stoppers for the "etriers" (6 pieces).

#### Re-rod for "Buses"

Vertical - 22 pieces of 8 mm re-rod @ 1.0 m length/1.80 well  
- 18 pieces of 8 mm re-rod @ 1.0 m length/1.80 well

Horizontal - Use 6 mm re-rod @ 15 cm O.C. (7 circumferences)  
Be sure to hook the ends of the 6 mm re-rod.

5. Oil the outside pieces of the mold and bolt them in place. (6 pieces).
6. Place the pipe "hole makers" and the brackets that hold them in place (6 pieces).
7. Bolt the triangle that holds the "etriers" in place.
8. Place the steel spikes in the holes in the mold.
9. Pour the cement, tamping it well.

Concrete Mixture for "Buses":

1.80 Well - 4 bags cement  
200 liters sand  
400 liters gravel

1.40 Well - 3 bags cement  
150 liters sand  
300 liters gravel

10. Keep the "buses" wet.
11. After about four hours, the three pipe "hole makers" and the steel spikes may be taken out.
12. After about 12 hours the mold can be taken off the base by lifting it a few cm. with a tri-pod and slipping the base plate out.
13. The "buse" must be kept wet for at least two weeks. Cover them with grass, mats, burlap, sand, or anything else. They should be kept in the shade if possible.

Usually there are four "buses" but in poor aquifers such as clay or mud, five "buses" may be used.

"Troussee Coupante"

The same amount of re-rod is used in the "trousse coupante" as in the "buses" except the length is 30 cm. The horizontals are three circumferences of 6 mm re-rod.

Concrete Mixtures for "Troussee Coupante":

1.80 Well - 2 bags cement  
150 liters of sand  
250 liters of gravel

1.40 Well - 1.5 bags cement  
100 liters sand  
299 liters gravel

The same curing procedure is used as for the "buses". One day is all that is necessary to build one "buse", therefore the building of the "buses" for a well should not take longer than

one week including taking the weekend off.

### Placing of the "Buses"

The "buses" are placed in the well by an OFEDES team using a derrick. The process is called "mis en eau". The procedure is as follows:

1. Place the first "buse" on top of the "trousse coupante" and bolt together.
2. Place the "trousse coupante" and "buse" in the well. Be sure the holes in the "buse" slope up toward the center, not down.
3. Place second "buse" on top of the first and bolt together.
4. Place four heavy boards between the "cuvelage" wall and the "buses". This will keep them going down straight.
5. Dig until "buses" have descended one meter.
6. Place third "buse" on top of second and bolt together. Continue digging until there is at least two meters of water in the well.
7. Put gravel behind "buses" to help filter the aquafer.
8. Place fourth "buse" on top of the third and bolt together.
9. Continue digging until there are at least three meters of water. Place fifth "buse" if necessary.
10. Finish placing gravel behind the "buse" and put at least 20 cm of gravel on the bottom to help keep the well clean.

The amount of water entering the well usually determines the depth of the reservoir. Even though large bailing buckets are used to keep water out of the well while digging, these are usually not sufficient to empty the well after three meters of reservoir. This is the volume OFEDES wants, therefore, the three meters are a sufficient reservoir. If the water enters the well at a slow rate, place a fifth or sixth "buse" in the well. This

whole process should take 7 to 10 days. The well is finished.

Under the existing system, once a well is finished OFEDES will return to clean the well once every two years. This is about the maximum amount of time permissible between cleanings because of the amount of material falling into the well and the amount of material that piles up around the margelle.

### Equipment for Masons

The following is the equipment assigned to each mason. Any losses are his responsibility.

- 2 a 4 seaux de 20 litres
- 1 seau italienne
- 4 pelles
- 1 pioche
- 1 griffe
- 1 niveau
- 1 clef a oeil ou clef a pipe
- 1 clef plat
- 1 burin
- 1 tenaille
- 1 poulie
- 30 a 50 m de cords de 22 mm, ou 1 treuil a main
- 1 regle
- 1 truelle
- 1 petite brosse metallique
- 1 tournevis
- 2 casque (chapeau dur)
- 1 tonneau
- 1 boite de controle de 100 litres
- 1 tamis
- 30 boulons
- 1 rouleau de fil de fer
- 1 moule a cuvelage
- 2 barre a mine
- 1 marteau
- 1 cords de surete a 30-50 m
- 1 ceinture



Most masons do not use these safety harnesses (centure) but there should be one at each site in case someone has to be evacuated from a well.

The well-digger should keep an inventory of materials distributed to each mason. Masons should be inventoried whenever leaving a village; they have a tendency to forget things.

### Responsibilities of the Masons

The mason is directly responsible for the construction of the well. He, of course, should be thoroughly trained before starting his own well. One way of training a new mason that has just started work for OFEDES is to place him with a good fifth category mason for a month or two to learn the techniques involved in I.H. wells. This is helpful when hiring a mason who has worked for the "circle" or for a private well-digging firm.

Once at the site the mason is responsible for the following:

1. The quality of the building materials such as sand and gravel. Most masons may have to be taught to recognize good quality material. Once they have learned this, it is their responsibility to control the material.
2. All safety procedures at the well site. He is ultimately responsible for the safety of all the men working at the well site. If he sees an unsafe situation, he should inform the Volunteer. He is even in his right to refuse to work in an unsafe situation until it is corrected.
3. The constant flow of necessary supplies to the site. He must always have a sufficient amount of sand, gravel, and water at the site before it is needed so that the operation will not bog down while the villagers bring in materials. He must also inform the Volunteer when he is getting low on cement, re-rod, wire, and anything else before he actually runs out. This allows time to restock the site.
4. For teaching the basic construction techniques. Since the masons do not have apprentices, the mason will have to teach the villagers concrete mixing, the work of a pulley and rop or winch, and basic well construction. Any mistakes made or accidents

occurring due to the ignorance of one of the village workers is the responsibility of the mason in charge, and he should understand this.

5. For the quality of all the work, most importantly the concrete. Poorly taught villagers are his fault.

6. For all equipment assigned to him and any damage to equipment past normal wear.

7. To keep the Volunteer informed of all information pertinent to the digging of the well. If there are any problems that develop or disagreements among the villagers, the Volunteer should be informed immediately.

8. For the medical care of minor cuts and scratches incurred in the work. He should be provided with a simple medical kit for this purpose. In the case of a serious injury, he should know the quickest means of evacuation and inform the Volunteer as soon as possible.

### Vehicles

Starting with the 1971 digging season, all well-diggers should have a vehicle. The rules here are good maintenance, common sense, and "for work only".

No vehicle is ever to leave its assigned department without prior approval from Niamey. The Volunteer, in most cases, will be allowed to take his vehicle into the city where his departmental office is located once at the end of each month to file monthly reports, buy groceries, and pick up necessary well equipment. Only in emergencies are vehicles allowed to go in at any other time.

OFEDES has a rule that no unauthorized personnel are to be transported in OFEDES's vehicles. This is mainly for self-protection. In the event of an OFEDES chauffeur having an accident in which unauthorized persons are injured, the chauffeur is fired and is responsible for all the damage suits filed against him. One "functionnaire" working for T.P. was sued for 1,500,000 CFA by the family of a man killed in an accident.

Anyone working at the well sites can be considered authorized personnel. They can be legally transported if it is for well work, but they remain the responsibility of the village chief who assigned them to the work. If a person is injured in an accident while working, the costs incurred will be covered by OFEDES's insurance.

People will be harassing the Volunteers constantly for rides. A policy of no passengers should be established from the beginning. If a Volunteer feels he cannot refuse to transport someone, have that person sign a paper releasing the chauffeur from all responsibility in case of an accident. This has to be signed by two witnesses.

#### Equipment to be carried in the vehicles at all times

Jerrycans with gas and water  
Tool kit  
Siphon Hose  
Wire  
Spare bolts  
Two (2) tire irons  
Big wrench  
Tire pump  
Hydraulic pump (jack)  
Tire patching kit  
Brake fluid  
Four (4) liters motor oil  
First Aid Kit  
Shovel  
Piece of wood to serve as base for jack  
Fan belt  
Drinking water

#### Well equipment to be carried in the vehicles "en tournée"

Tape measure (100 meters)  
Old oil (huile de vidange)  
Wire (file de fer)  
Rope (corde de 50 ou 100 metres)  
Extra bolts for molds (no. 22 bolts)  
Plumb and string  
Axle bolts for pullies  
Extra wire cutter and trowel

Continual maintenance of one's vehicle is very important in Niger. Every day the radiator, battery, oil level, brake fluid, tire pressure, and lug nuts should be checked. For more extensive care, follow the maintenance schedule found in the Owner's Manual of each vehicle. Remember, there are no replacements for these vehicles.

### Transportation of Materials

Normally OFEDES will be responsible for transporting all materials to the sites or central magazines. OFEDES will either use their own trucks or hire truckers, especially when transporting cement from Malbaza.

The central magazines are always located on one of the major roads where they can be supplied by fifty-ton trucks. These roads will have to be fairly free of sand such as the Route Nationale or one of the major roads connecting Arrondissements such as the road to Bouza, Dakoro, Magaria, Filingue, etc. From these magazines, the materials are supplied to the sites by OFEDES trucks, the Sous-Prefet's trucks, camels, donkeys, carts, or on the top of villagers' heads. This depends on the distances involved, the Arrondissements, and the type of program the Volunteer is running. Some programs such as the one in the Agye region of Tessaoua used villagers to transport all the materials to the sites. Other regions such as Dogondoutchi used OFEDES vehicles to supply the cement and re-rod. Mayahi used both OFEDES and the Sou-Prefet's trucks to supply the gravel, cement, and re-rod. When possible it is always better to use the local means of transporting materials because the OFEDES trucks are not always available. If the villages are too far from the magazine or unable to transport the materials, try using the Sous-Prefet's trucks to supply the sites.

The more the Sous-Prefet is involved in the I.H. program, the better the program will work. As of October, 1970, each Arrondissement must contribute monitarily for transporting the materials in the Arrondissements. This is usually 20% of the budget for the materials for each Arrondissement. In a case such as Mayahi with a budget from OXFAM of 6,700,000 CFA, the Sous-Prefet is expected to contribute 1,340,000 CFA for transport.

Both the OFEDES trucks and the Sous-Prefets' trucks can carry five tons of materials or three cubic meters of gravel. Three cubic meters of gravel is sufficient for 6 meters of a 1.80 well or 7.5 meters of a 1.40 well. Three extra loads should be added for the "margelle", "buses", and the gravel packing behind the "buses".

### Reports

At the end of each month, a report of the well progress in each Arrondissement has to be sent to OFEDES/Niamey by the departmental directors. If the director has not been able to make a "tournee" before the end of the month, the Volunteer will have to supply the necessary information. The format is as follows: name of mason, name of village, Arrondissement, depth at first of month, depth at end of month, total depth realized for the month, cement used, re-rod horizontal used, re-rod vertical used, and observations such as date the well was started or finished and type of substrata being excavated. The directors have blank forms for "Rapport Mensuel des Puits par I.H." in their offices. It is a good idea to keep a few blank copies at each post.

A second report that should be written at the end of each month is a progress report for the Sous-Prefet. This should include the names of wells started or finished during the month and the progress at each well site. If there are any problems, state what they are and how they might be remedied. If the Volunteer is working on well-related projects, these should be included in the report. A copy of this report should be sent to the departmental director for his records and another to the Peace Corps staff in charge of the well program.

At the end of a digging season, an extensive report should be made on the year's work. This should include the Arrondissements worked in, co-operation received from the Sous-Prefet and Chefs de Cantons, special problems encountered, and why certain villages could not support the I.H. program. A separate list should be made for all the masons used, their characteristics, quality of work, and recommendations for the next Volunteer to have them. This information will not only keep the future Volunteers from making the same mistakes, but will

prove to be invaluable when entering an Arrondissement formerly worked in.

### Community Development Projects

Most Volunteers working in large-bore wells will find that the supervision of these wells will not fill all of his time. However, one of the advantages of large-bore well construction is the amount of community development projects that can be started in co-ordination with the finished wells. Some of the potent possibilities are:

1. Water-lifting systems placed over the wells that enable the development of garden and orchard irrigation systems. Some water-lifting systems that have been used with varying success are the Tuareg water-lifting system, the shadoof, the bike-wheel crank-shaft system, a rotational water-lifting device involving horizontal and vertical gears, and the pump.
2. If the well is in a village that has a primary school, animate the teachers to get a school garden project going for the students. For further information see Jon Otto's report on his school garden projects.
3. Work with "Service d'Agriculture" or "Eaux et Forets" to initiate orchard, garden, or nursery projects.
4. Watering troughs for cattle. These can be made indigenously with banco bricks covered with a thin veneer of concrete or by setting up a log framework stuck together with banco clay and also covered by a layer of concrete.
5. Superstructures built of the margelle for sanitation purposes. One idea is the use of a sloping apron from the margelle to ground level.
6. The use of small-bore wells as a supplementary supply of water to villages with water tables of less than 25 meters. This would offer a relatively sanitary water system for drinking water. Either the bailing-bucket type well or the closed Chad type could be used.

7. If a village seems to be receptive to the idea of sanitation, it may be possible to introduce public health Volunteers to work with the village on well sanitation, health principles, etc.

Other projects include farming projects using traditional methods as compared to more advanced practices using fertilizer, etc.; chicken farms, or raising rabbits.

### Statistics

OFEDS counts re-rod according to weight rather than length. The following statistics on reinforcing rod will help in making monthly reports and supplying the right quantity of re-rod at each site.

#### Weights:

8 mm = 395 grams per meter

6 mm = 222 grams per meter

1 ton 8 mm re-rod = 14 pkgs @ 20 bars/pkg @ 9.25 m/bar

1 ton 6 mm re-rod = 16 pkgs @ 30 bars/pkg @ 9.12 m/bar

1 pkg 8 mm re-rod = 182.4 m

1.40 well = 5.5 "cuelages" of vertical re-rod  
(22 pieces @ 1.40 m per "cuelage")

1.80 well = 4.5 "cuelages" of vertical re-rod  
(26 pieces @ 1.40 m per "cuelage")

1 pkg 6 mm re-rod = 273.6 m

1.40 well = 6.0 "cuelages" of vertical re-rod  
(30 pieces @ 1.50 m per "cuelage")  
= 7.5 "cuelages" of horizontal re-rod  
(7 circumferences @ 4.8 m/circum/"cuelage")

1.80 well = 4.5 "cuelages" of vertical re-rod  
(40 pieces @ 1.40 m per "cuelage")  
= 6.0 "cuelages" of horizontal re-rod  
(7 circumferences @ 6.0 m/circum/"cuelage")

## Weight of Re-rod According to Cuvelage

### 1.40 Well

| <u>Cuvelage</u>          | <u>Margelle</u>           |
|--------------------------|---------------------------|
| Vertical 8 mm = 12.3 kg  | Vertical 8 mm = 40.0 kg   |
| Vertical 6 mm = 10.0 kg  | Vertical 6 mm = 32.0 kg   |
| Horizontal 6 mm = 7.5 kg | Horizontal 6 mm = 26.4 kg |

### 1.80 Well

| <u>Cuvelage</u>          | <u>Margelle</u>           |
|--------------------------|---------------------------|
| Vertical 8 mm = 14.6 kg  | Vertical 8 mm = 47.3 kg   |
| Vertical 6 mm = 13.3 kg  | Vertical 6 mm = 41.0 kg   |
| Horizontal 6 mm = 9.5 kg | Horizontal 6 mm = 35.0 kg |

### 4 "Buses" and "Trousse Coupante" for a 1.40 Well

|   |                  |
|---|------------------|
| 3 bags of cement/buse + 2 bags for trousse coupante | = 14 bags        |
| 18 pieces 8 mm re-rod vertical @ 1.0 m/buse by 4.5  | = 32.4 kg        |
| 7 circumferences 6 mm re-rod @ 2.4/buse by 4.5      | = <u>16.3 kg</u> |
| Total   | = 48.7 kg        |

### 4 "Buses" and "Trousse Coupante" for 1.80 Well

|   |                  |
|---|------------------|
| 4 bags of cement/buse + 2 bags for trousse coupante   | = 18 bags        |
| 22 pieces of 8 mm re-rod vertical @ 1.0 m/buse by 4.5 | = 39.6 kg        |
| 7 circumferences 6 mm re-rod @ 4.8 m/buse by 4.5      | = <u>33.3 kg</u> |
| TOTAL   | 72.9 kg          |

1 inch = 2.54 cm  
12 inches = 30.48 cm  
1 yd. = 91.44 cm  
1 liter = 1.06 qt  
1000 liters = 1 meter<sup>3</sup>

1 meter = 39.37 inches  
1 mile = 8/5 km  
1 km = 5/8 mile  
1 kg = 2.2 pounds



# 4. UPPER VOLTA, WELL DIGGERS'S MANUAL

Frederick L. Matthews, Jr., 1973

*Editor's note: The following article is based on a well manual developed as an aid to new Volunteers in their first year as well diggers in Upper Volta.*

## **Organization**

Organization, one large word that if used correctly will diminish the hassles you will encounter as a well digger in Upper Volta. First you should keep constant track of your tools and cement. Charts 1 and 2 on the following pages, give you an idea of one way to keep track of them. Chart 3 shows the report forms that you must fill out for each month: one to the commandant, one to O.R.D., one to H.E.R., one to Peace Corps Ouagadougou, and one for yourself. Chart 4 is the inventory form, for this year, of the tools you will receive. Chart 5 is the inventory form you will use at the end of the well season. This is your requisition form for new equipment the second year. The placement of cement form, that you will bring into Ouagadougou before Christmas, will speed up shipping of cement and supplies immensely. Some volunteers have had to wait all year just to receive their cement. This new system should change the

above problem this year.

This year, the H.E.R. would like for us to survey the old and new wells in our regions. None of us are map makers; but anytime you see an old well, then write the names of the village, cartier, depth, depth of water, and if it is Peace Corps.

## **Timing of Wells is Important:**

Rather than doing each well as a separate project from start to finish, try to divide the work into digging and pouring. Dig only at first. When there is water without any major and continuous caving—leave the well. If the water table drops you can continue to dig without cement already poured, thus saving the trouble of digging and pouring. Then, near the end of the season you can go on to cement all the wells already dug. If there is water late in the season you are more apt to have a good well that won't need deepening than if you cement early.



# CEMENT CHART

| CEMENT CHART |            |    |    |              |    |       | Magazine |     |  |  |
|--------------|------------|----|----|--------------|----|-------|----------|-----|--|--|
| Village      | Date Taken |    |    | No. of Sacs. |    | Total | ISED     | RET |  |  |
|              | Trips      |    |    |              |    |       |          |     |  |  |
|              | 1.         | 2. | 3. | 4.           | 5. |       |          |     |  |  |
|              |            |    |    |              |    |       |          |     |  |  |
|              |            |    |    |              |    |       |          |     |  |  |
|              |            |    |    |              |    |       |          |     |  |  |
|              |            |    |    |              |    |       |          |     |  |  |
|              |            |    |    |              |    |       |          |     |  |  |
|              |            |    |    |              |    |       |          |     |  |  |
|              |            |    |    |              |    |       |          |     |  |  |
|              |            |    |    |              |    |       |          |     |  |  |

107-a

CHART 2

| <b>Post:</b> |         | <b>Puisatier:</b> |                |               | <b>Situation à la Fin de mois:</b> |                |                 |              |              |
|--------------|---------|-------------------|----------------|---------------|------------------------------------|----------------|-----------------|--------------|--------------|
| No. du Puit  | Village | Quartier          | Date Commencée | Metres Creusé | Hauteur Déau                       | Metres Cimente | Sacs de Cimente | Date Termine | Observations |
|              |         |                   |                |               |                                    |                |                 |              |              |
|              |         |                   |                |               |                                    |                |                 |              |              |
|              |         |                   |                |               |                                    |                |                 |              |              |
|              |         |                   |                |               |                                    |                |                 |              |              |
|              |         |                   |                |               |                                    |                |                 |              |              |
|              |         |                   |                |               |                                    |                |                 |              |              |
|              |         |                   |                |               |                                    |                |                 |              |              |
|              |         |                   |                |               |                                    |                |                 |              |              |
|              |         |                   |                |               |                                    |                |                 |              |              |

VILLAGE \_\_\_\_\_

PCV \_\_\_\_\_

DATE \_\_\_\_\_

## CHART 4

**INVENTAIRE D'EQUIPMENT DES PUITs**

| ARTICLES                  | CHARGEMENT ORIGINAL | DATE | CHARGEMENT SUPPLEMENT. | DATE | CHARGEMENT SUPPLEMENT. |
|---------------------------|---------------------|------|------------------------|------|------------------------|
| Moule-1 mètre             | 3                   |      |                        |      |                        |
| Moule-5 mètres            | 2                   |      |                        |      |                        |
| Moule à buse              | -                   |      |                        |      |                        |
| Moule à brique            | 1                   |      |                        |      |                        |
| Moule de trousse coupante | 1 shared            |      |                        |      |                        |
| Grand seau                | 5                   |      |                        |      |                        |
| Seau italien              | 21                  |      |                        |      |                        |
| Pelle                     | 21                  |      |                        |      |                        |
| Pioche                    | 15                  |      |                        |      |                        |
| Barre à mine              | 3                   |      |                        |      |                        |
| Poulie américaine         | 9                   |      |                        |      |                        |
| Poulie française          | 15                  |      |                        |      |                        |
| Planche                   | 12                  |      |                        |      |                        |
| Fer à U                   | 20                  |      |                        |      |                        |
| Casque                    | 30                  |      |                        |      |                        |
| Coupe boulons             | 1                   |      |                        |      |                        |
| Niveau                    | 3                   |      |                        |      |                        |
| Maillet en caoutchouc     | 1                   |      |                        |      |                        |
| Marteau de forgeron       | 1                   |      |                        |      |                        |
| Marteau à griffe          | 6                   |      |                        |      |                        |
| La scie à métaux          | 4                   |      |                        |      |                        |
| Fût d'huile               | 100 litres          |      |                        |      |                        |
| Pince universelle         | 3                   |      |                        |      |                        |
| Double mètre              | 3                   |      |                        |      |                        |
| Truelle                   | 3                   |      |                        |      |                        |
| Fil de fer                | 25 kgs              |      |                        |      |                        |
| Corde                     | 700 m               |      |                        |      |                        |
| Ficelle                   | 400 m               |      |                        |      |                        |
| Plomb 606 planche         | 20                  |      |                        |      |                        |
| Paire de griffes          | 2                   |      |                        |      |                        |

VILLAGE \_\_\_\_\_

PCV \_\_\_\_\_

DATE \_\_\_\_\_

## CHART 5

**INVENTAIRE D'EQUIPMENT DES PUITES**  
**et**  
**REQUETE D'EQUIPMENT SUPPLEMENTAIRE**

| ARTICLES  | UTILI-<br>SABLE | NON UTILI-<br>SABLE | REQUETE PR<br>L'ANNEE<br>PROCHAINE | REMARQUES |
|---|-----------------|---------------------|------------------------------------|-----------|
| Moule-1 mètre<br>Moule-5 mètres<br>Moule à buse<br>Moule à brique<br>Moule de trousse coupante<br>Grand seau<br>Seau italien<br>Pelle<br>Pioche<br>Barre à mine<br>Poulie américaine<br>Poulie française<br>Planche<br>Fer à U<br>Casque<br>Coupe boulons<br>Niveau<br>Maillet en caoutchouc<br>Martéau de forgeron<br>Marteau à griffe<br>La scie métallique<br>Fût d'huile<br>Pince universelle<br>Double mètre<br>Truelle<br>Fil de fer<br>Corde<br>Ficelle<br>Plomb 606 planche<br>Paire de griffes |                 |                     |                                    |           |



## Choosing the Well Site

1. The methods to choose a site are best left to the sourcier-douser or to someone in the village who the villagers trust, like an elder or the chef du village.

### The Sourcier-Douser:

The people will bring him or you can yourself. He knows the logical if not guaranteed places to find water. A dry hole is his responsibility and not yours. The villagers trust him and will keep digging until water is found. His services are paid for by the village. It's worth the time and effort to find a sourcier-douser and it's very interesting.

### The Chef du Village or Elder:

The chef du village or elder usually knows where a source of water can be found. Also, the people will have more faith in his decision than yours. The main fault in using this method is that sometimes a well site is chosen more for proximity to the concession than for the possibility of finding water.

### YOU:

If you're left with the decision of finding the well site, then here is an article by Mead Over to follow.

How to avoid granite and find water . . . some of the time.

#### I. Information to ask for in each village:

1. If the villagers tell you they once had a successful well which has since caved in, **DIG THERE** with no further questions asked. Be happy that you had your hardest decision made for you.

2. If the village has never had a well, question them about the attempts made and why those attempts failed:

(a) Did they just get tired?—at what depth?

(b) If so, did rain cause it to cave in or was the dirt simply too weak to hold up the walls?—again at what depth?

(c) Or (shudder) did they hit granite? If so, ask about any other holes they may have dug and the presence of granite in each? What was the depth of the granite in each (in man height)?

3. In case a) a new site must be chosen completely and independently. (see below)

4. In case b) if it is ascertained that the well caved in because the soil was too loose to hold—not simply because the rains came—it may be worthwhile to dig again in the same area. Loose soils of this type

are quite likely to be water-bearing. Once the loose soil is hit by the diggers, the well must be continued by the dig-a-meter-pour-a-meter method to avoid the danger of cave-ins. If, on the other hand, rain caused the cave-in, the situation is the same as in item a.)

5. If the villagers have hit granite once or several times, the situation is the same as in item a, with the exception that the volunteer has more information to base a decision on: i.e., he knows more places not to dig.

### How to decide a site:

Upper Volta has two topologies. The first can be seen from the Boeing 727 jet before you land. The second will only be met after the well digging season has started. But before the two years are over, this second face of Upper Volta will become far more emotionally charged than the first. The second topology is that of the granite bed which is never very far beneath either the feet or the shovels no matter where you go in the southeast.

Since granite is impermeable to water, it will hold all the water which falls to it. If soil conditions are favorable, this water will flow downhill into depressions, hollows and crevices which that bed contains deep underground. The well-digger must penetrate to one of these reservoirs if he is to build a year-round well. Furthermore, if the well is to last the dry season, the reservoir must be a relatively large one. But how does the volunteer locate one of these invisible reservoirs?

Although most villages will have tried several times to dig wells in their immediate vicinity, few will have ever sunk a hole more than a hundred yards from the group of habitations. Most attempts will have been made within a short walk of the chief's concession. Since all villages are situated on the highest ground available and since the surface of the ground tends to vary much more than the bedrock underneath, the villagers will frequently have dug wells in one of the following situations:

2. In diagram "A" the villagers will have dug their attempt at point (1), and failed to find water for one of three possible reasons. First the ground may have become soft and the risk of a cave-in scared them off. (see 4 in the first section). If the marigot or other low point appropriate for a site (2) excavation is more than a kilometer away, a well could be sunk again at site (1) with the dig-a-meter method being used after loose soil is reached. However, if the



marigot is closer than a kilometer, it is probably a better idea to use site (2) where the effect will be reduced and the chances of hitting water increased. Secondly, diagram "A" may pertain if the diggers

DIAGRAM: (A)

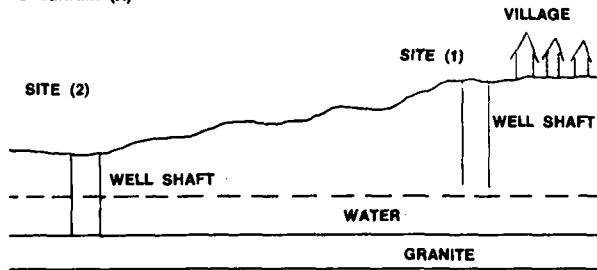

stopped their site (1) excavation simply because they became tired. In this case the well site should probably be moved to site (2), since there is no evidence that a deeper excavation at (1) would have hit water. Thirdly, the villagers may have hit an underground boulder between the surface and the water table. In most cases the volunteer will have no way to tell whether the previous site (1) excavation actually hit a boulder or whether diagram "B" actually pertains and the villagers hit the actual granite bed. But even if he is convinced that the granite was only a small boulder which would be avoided on any adjacent site, he should move his site to (2), unless the low-point site really is over the horizon.

DIAGRAM (B)

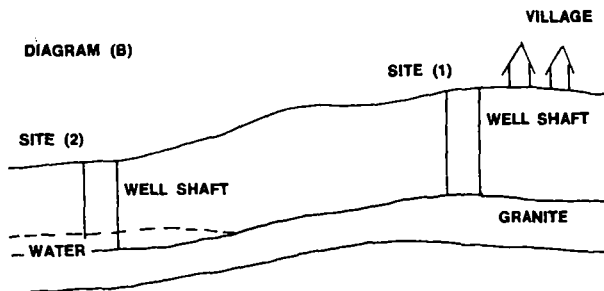

The diagram "B" villagers will have dug their attempt at site (1) and hit granite. However, site (2) will often prove to be quite successful because the granite frequently echoes the topology of the ground above it. Note should be taken of the height of site (1) above site (2) and this figure should be compared with the reported depth of the granite at site (1). Also the volunteer should check carefully along the intervening hillside between (1) and (2) to be sure that the granite doesn't break the surface of the ground. If it does, site (2) will probably be right in the middle of the hard-as-steel granite bed. In this latter case a different low point must be looked for

in another direction.

The primary characteristic of site (2) is that it is DOWN from the village and thus closer to the water table. But there are usually several low points which surround any given village. The Volunteer must be able to choose the best one.

For this purpose he must be sure he knows the location of every marigot or water source within walking distance and he must see them to judge their relative sizes.

A plan for a typical village layout might look like this:

DIAGRAM (C)

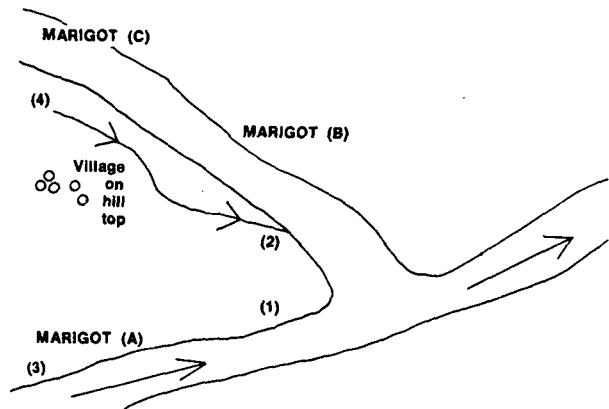

The villagers will prefer the sites in the order of their closeness to the village, but the volunteer must prefer them in the order they are numbered. There is some doubt about the ordering of (2) and (3), which must be decided on the size of marigot (b + c) relative to marigot a. Once the volunteer knows his preference, he must determine the site by compromising between his own list and that of the villagers, being sure to drive the hardest bargain he can. In cases of doubt he should pick the better water source. If work ceases at the preferred site, he can always retreat to the less favorable one that is more desirable to the villagers. "But he shouldn't even hint at this possibility until he is forced to."

There is one dangerous possibility that should be specifically warned against. When a volunteer questions villagers about water sources, they are inclined to tell him only of those within their own territory. If a much better marigot is in the territory of another village, they will withhold information on it, assuming that a well dug there would belong to the other village. A map of the situation would look like this:

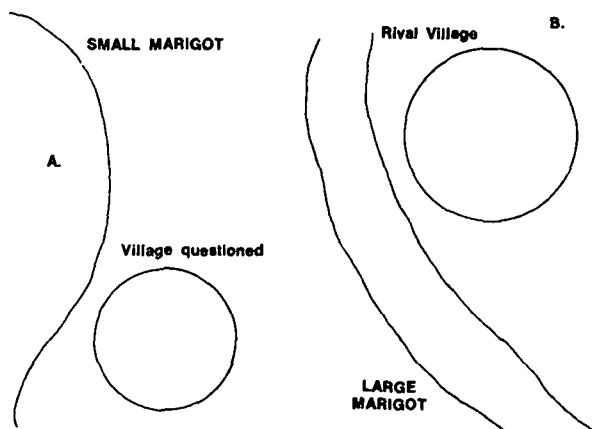

Although the small marigot near the questioned village may look quite promising the cut-away view along line a.xxx b. might reveal a situation like this:

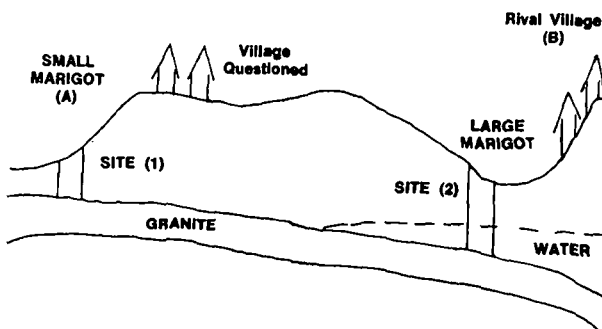

Obviously, no matter how close site (1) gets to the small marigot, it will never touch the underground water supplies. Site (2) is the only feasible place for a well despite the intervening hill and the fact that (2) is in the rival village's territory. In this situation, if the chiefs of the two villages cannot be reconciled to cooperate on one well, the Volunteer should be willing to dig two wells, both near site (2).

If the Volunteer follows the above rules, remembering to keep an eye out for rocky outcroppings on one hand and bright green oasis-like spots on the other, he should hit water the vast proportion of the time.

#### When you do hit granite

Despite all precautions, all Volunteers will hit granite with a frequency ranging from hardly-ever to far-too-often, depending on the region to which they are assigned. However, it is possible to dig in some of the softer varieties of granite. One village is known to have dug over ten meters in material so hard that the

mining bar rang on contact. Obviously this is extremely hard work and only the most motivated of villages will continue under this condition.

The Volunteer who hits diggable granite is on the horns of a dilemma. Even if the village digs through to water, it is unlikely that the well will have a very high capacity, because decomposed granite is a very poor aquifer. There is a chance that the granite is just a boulder which will be penetrated, or that there will be a water-bearing crevice just a foot farther down. But these are extremely long shots. However, if the volunteer decided to move to a new site, the villagers may be too discouraged to start all over. The decision to move or not to move must be made, like all the other decisions mentioned above, by YOU.

#### Reinforcement Rod

##### Why reroed?

Concrete by itself, without reinforcement, can only resist compressive forces. When bent or pulled, it cracks. Thus a brick, which is subjected only to the compression of the bricks above it, needs no steel, while a beam or a column which has to resist bending, must be reinforced.

A well that is dug in hard soil is held up by two forces. The whole column of concrete is held up from the bottom, (providing it is resting on hard ground). The weight of the concrete is also supported by adhesion to the rough surface of the soil. In hard ground, the force of adhesion alone is usually enough to hold up the weight of the concrete. In soft soil or mushy ground, where the soil is more fluid, the force of adhesion is obviously not as great.

Thus a well that goes down into firm ground is self-supporting, and is subject mainly to the compressive force of the earth around it and its own weight. A small amount of reinforcing rod is needed, however, to compensate for the uneven stresses that may result from cracks or soft spots in the earth or because the column is not perfectly vertical.

On the other hand, a work that goes down into soft or fluid soil is not self supporting. First of all, its bottom is not resting on firm ground. Secondly, the force of adhesion is reduced or nonexistent. Thus the weight of the concrete in the lower section is hanging from the concrete above it, subjecting it to a stretching force. As concrete by itself has no elasticity and thus no resistance to stretching, this means that far more steel is needed.

The old volunteers may scuff as they have often worked on wells that have gone into soft or fluid soil, which were constructed using little reroed and

which have held up. That may be. But the problem often becomes apparent only when the well is deepened. Then soil is removed from the bottom, the soft soil flows down from behind the bottom part of the well casing, and the bottom rings of the casing are virtually left hanging in mid air. If the steel is insufficient, the bottom rings will crack or fall off. This may be unpleasant for the men who are working at the bottom of the well, as well as difficult to repair.

So, for the wells that go into firm soil or fluid soil I have made a small ratio chart. The reason for the PC group is that sometimes you will run low on rerod and cannot get any more till the next season, so you are forced to diminish the number of rerod per well to complete the season.

| HER | Firm soil | PC | HER | Fluid soil | PC |
|-----|-----------|----|-----|------------|----|
| 16  | Verticals | 12 | 24  | Verticals  | 16 |
|     | Mim.      |    |     | Mim.       |    |
| 3   | Circles   | 3  | 5   | Circles    | 4  |

\* Meter mold

### REINFORCEMENT ROD

#### Horizontals or Circles:

These horizontals should be prefam on top by bending the five meter lengths around stakes set into the ground. Then, securing the overlap with wire. dia:

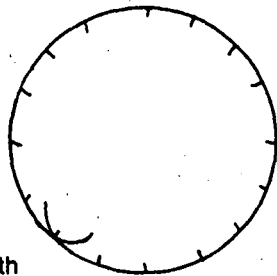

5 meter piece of rerod with about a 30 cm overlap.

Spacing of the horizontals:

1/2 meter mold. Space 12 1/2, 37 1/2 cm from bottom of mold.

Meter mold, Using

- 3 circles each meter. 15cm, 50cm, 85cm.
- 4 circles each meter. 15cm, 40cm, 65cm, 90cm.
- 5 circles each meter. 10cm, 30cm, 50cm, 70cm, 90cm.

Circles must always be tied to *all* the verticals with wire to give a strong bond to the rerod frame. They are placed on the outside of the verticals, meaning the circles are nearest the dirt wall.

#### Verticals:

These are precut at your house in 3 meter lengths. The first framework or ground level verticals are

bent into an L-shape (30cm). The bottom line of the L resting on the ground. This is a better method than the old one. (trying to push or drive 30cm into the ground.)

#### Attaching:

It is important that the rerod be properly attached to one another. Many of the old volunteers have been in the habit of simply hooking the rerod from one meter around the ends of the rods that come down from the previous meter. This is not a good practice, and drastically reduces the resistance of the well. The ends of the rods should be hooked, and the rods should be wired together with at least 30cm of overlap. dia:

Hooks at end of rerod to grip into concrete.  
Fills de fer to bind rerod together.  
30cm of overlap for support  
Ground vertical  
3 meters in length  
30cm L-extension

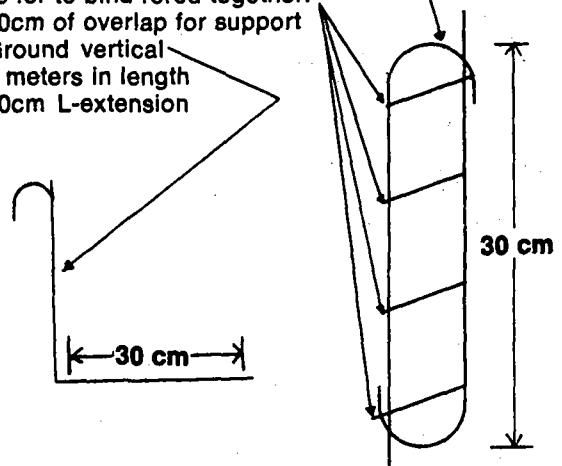

Do not get oil on the rerod, concrete will not adhere to the oily rods.

### CONCRETE

#### Mixtures:

It is important that your concrete be well mixed and of the proper proportions. This means that the dry materials should be mixed to a uniform color before the water is added. It should not have streaks of sand in it. Add just enough water to be able to mix the ingredients. Too much water drastically reduces the strength of the concrete. The concrete should be well compact in the mold. You should tamp the mold and the concrete with a stick. But do not tamp so much that you push the rocks to the bottom of the mold.

**Proportions:**

|     |        |        |
|-----|--------|--------|
| HER |        | PC     |
| 1   | cement | 1      |
| 2   | sand   | 2      |
| 3   | gravel | 4 or 5 |

**Remember:**

- To use the same size buckets when mixing.
- To keep foreign matter out of the mixture. (grass, leaves, twigs.)
- Do not add too much water.
- Mix thoroughly.

**Platform Mixtures:**

1. Take 8 buckets of sand and 1 bucket of cement. Cure for two days. This will make a large oval platform.
2. Take 7 buckets of sand and 1 bucket of cement. Cure for two days. This makes a 3 meter by 1½ meter square platform.

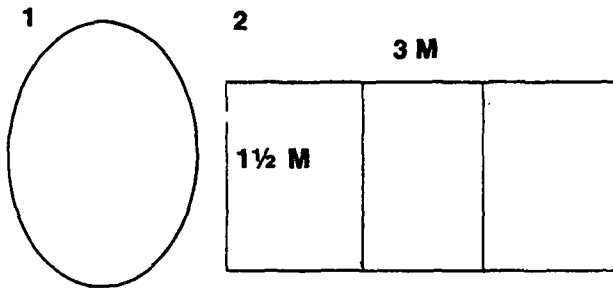

**Curing Concrete:**

It is important that concrete be properly cured, meaning that it is kept wet for a number of days. Concrete which has been cured for 14 days is approximately twice as strong as concrete cured for 3 days. It is difficult to keep the concrete wet, due to lack of water or the villagers will not do this because they see no future in it, but every effort should be made to do so. The margelle, as an experiment, should be covered with burlap, sand, grass, or some other water holding material and kept wet for several days to strengthen itself.

**MOLDS**

Molds are rings of reinforced sheet stool. Yours are 140cm in diameter and come in meter and half meter heights. They demount into three sections for transport, cleaning, etc., and have a small door for breaking inward to free them from the cast ring.

**Some points to remember:**

The mold should always have a thin layer of oil spread on it. This not only makes it best for storage, but makes it easier to keep clean and much easier to remove once the cement has set. The mold should be oiled every 3 meters.

The mold should be cleaned after the completion of a well.

**SUPERSTRUCTURES**

The *margelle* is a simple ring of concrete usually 75cm high and 20cm thick which encircles the top of the well. Its main purpose is to prevent animals, children, and other living things from falling into the well. There are a number of methods that have been used to construct margelles in Upper Volta. Two examples:

1. Laterite brick method—a regular well mold is placed on the last meter of concrete ring and fastened in place as if one were preparing to pour a ring in the normal fashion; then, using laterite bricks, one constructs with mortar a brick wall around the wall utilizing the mold as a stabilizing factor.

2. Mud brick method—the mold is set in place (as described above) and a circle of locally made mud bricks is placed around the mold at a distance of 20cm. Concrete is poured in usual fashion and the mud bricks may be broken away when the ring is dry.

The *dale* is essentially a concrete platform extending from ½ to 1 meter from the margelle in all directions. Its purpose is to keep the area surrounding the well relatively dry and sanitary. It should be graded in order that water spilled from buckets may not gather in pools, but not graded so steeply that an ordinary bucket could not rest securely upon it. (see dia.)

**MARGELLE AND DALE**

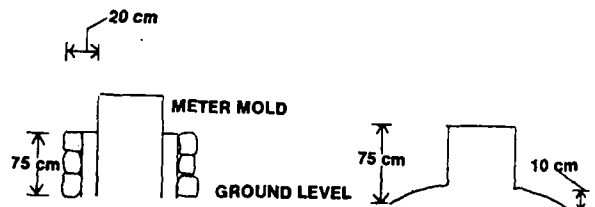

## MARGELLE AND DALE DIG DOWN-POUR UP CONSTRUCTION

### Tools:

1. 1 plumb bob, board, and string. 4—15cm pieces of rerod.
2. 1 pick
3. 2 shovels
4. 1 tape measure
5. 3 buckets, 1 large and 2 small.
6. 1 hammer
7. 1 pliers
8. 1 baromine (if needed)
9. 1 rerod cutters (if needed)
10. 1 trowel
11. 2 hard hats
12. 2 pulleys and 2 ropes
13. 4 U-iron and 2 platform boards
14. 1 meter mold.

Materials: 1 tamping stick, 1 measuring stick—160cm long, wire and rerod, 4 supports, 1 cross beam, 2 Y supports, and 1 brake post.

### Start of Well:

Clear the ground surface 3 to 5 meters in circumference. Inscribe a 160cm circle onto the surface using your measuring tools. (see diagrams: p. 22) Plumb-bob, plumb-bob board, string and rerod stakes, and measuring stick. Deepen the inscribed line and dig down  $\frac{1}{2}$  meter. While the villagers are digging cut a stick 160 cm in length, find the center point and cut a small line around it. This stick has two purposes:

- 1) It is used as a measuring stick to insure the well remains 160cm in width.
- 2) It is used in connection with the plumb-bob and line to insure that the well remains plumb (straight).

After the  $\frac{1}{2}$  meter has been dug then demonstrate the significance of the measuring equipment. The measurements should be taken every meter to insure the good hole. The villagers usually will not use the plumb-line, so make a habit of measuring with the plumb line and stick every time you visit a well site.

### Digging the Well:

After the first meter or two, you set up the lowering supports. 2 forked logs  $2\frac{1}{2}$  meters in length with a minimum thickness of 25cm, are placed on each side of the well to a depth of  $\frac{1}{2}$  meter to support a transverse log. The cross piece is placed on

the forked (Y) logs and as a safety precaution, rerod is wrapped tightly around the supports and the crosspiece. 2 pulleys are attached securely with rerod to the crosspiece. If the pulleys are the French type then wire must be wrapped around the open hook so there is no chance of the pulley being jerked from the rerod. The American pulley has a safety latch and it is not necessary to wrap it. The brake post is placed into the ground opposite the pulleys, back about 4 to 5 meters from the well. This log should be smooth. All logs (supports) should be strong, straight as possible, and without termite damage.

As the villagers dig have them place the dirt so that it will wash away during the rainy season and far enough away so it will not interfere with the traffic around the well. You must dig until you have a good supply of water. The deeper you dig past the water source, the deeper reservoir you will obtain.

### Entering and Leaving the Well:

This will be demonstrated during the stage.

### Placement of Rerod:

Verticals are cut to lengths of 3 meters. First meter has a L-shape (30cm) so that the well may be deepened in the future. Whenever needed, 3 meter vertical extensions are added attaching together with the 30cm overlap and hooking. (see reinforcement rod).

### Horizontals or Circles:

Circles are prefam on top, 5 meters in length, and placed in their positions of 15cm, 50cm, 85cm, from bottom of the mold. The circles are tied with wire to every vertical. Remember to place on the outside of the verticals, meaning closest to the dirt wall. Solid soil use 16 verticals, 3 circles each meter.

### Lowering the Mold:

Assemble the mold on top. Using rerod, attach pieces to the handles on the interior of the mold forming a triangular support. (see dia.)

With the help of the villagers, move the mold to the edge of the well. Oil the exterior of the mold and place logs over the well. Attach the pulley rope to middle of the rerod support. USING the BRAKE POST, lower the mold after removing the logs. If the rerod pieces were of equal length and attached in the same way then the mold should descend evenly and without hanging up on the sides.

Using the plumb bob and string, center the mold and level. Make sure that none of the rerod frame is touching the mold.

# CONSTRUCTION DIAGRAMS

## DIGGING

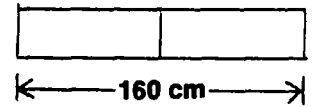
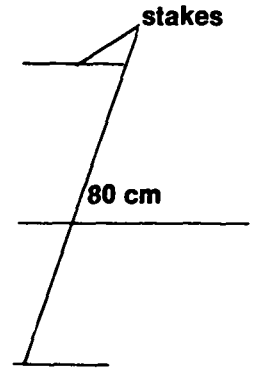
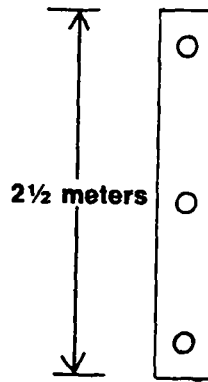
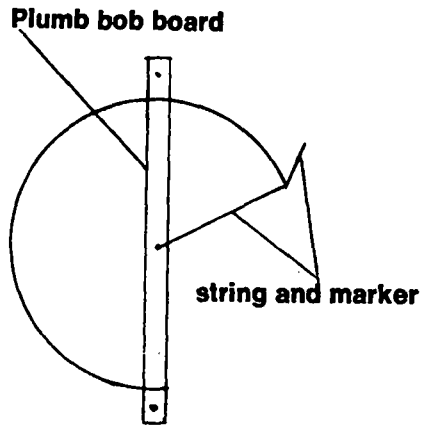
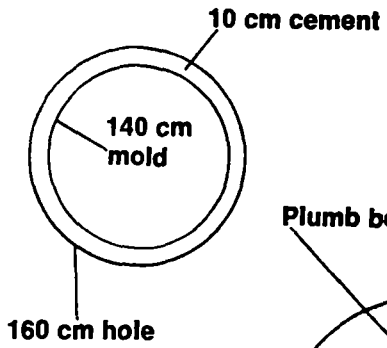

## MOLD RAISING

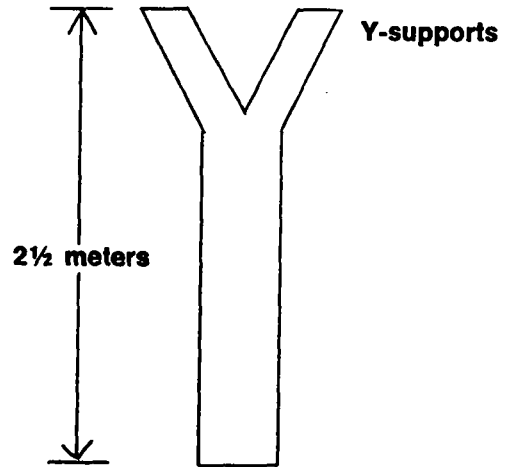
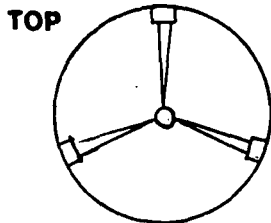
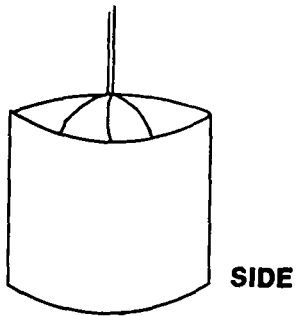

## CEMENTING

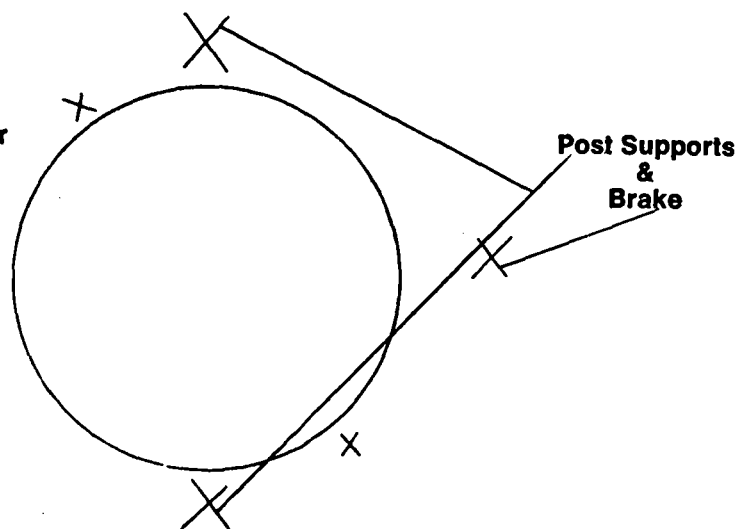
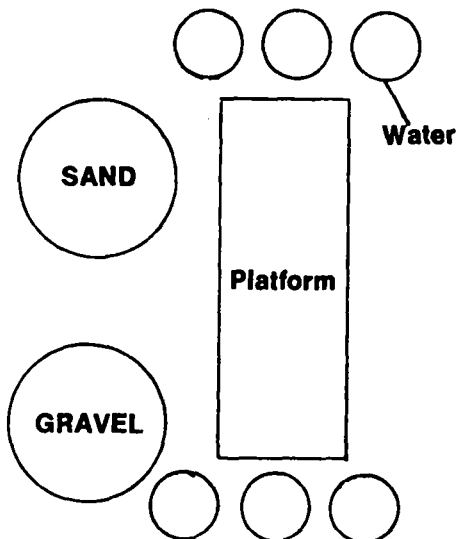

### **Mixing and Platform:**

The platform should be made 2 to 3 days before the first meter is poured. This is to allow for curing. (See concrete).

When mixing use the 1 cement, 2 sand, 3 gravel formula. Use the same size bucket when mixing. You'll need from 2½ to 3 sacks of cement for each meter.

### **Pouring:**

Concrete is poured directly into the space between the mold and the sides of the hole. A few buckets should be poured on one side and then the opposite side, continuing around the mold in this manner. This is done to prevent concrete from piling up on one side, causing the mold to shift. Periodically the mold should be tamped with a stick to settle the concrete and to eliminate air bubbles. When the mold is filled then using the trowel, level and smooth the top of the concrete ring.

### **Successive Meters:**

The concrete is dry and you're ready to raise the mold.

Attach new extension rerod if necessary and circles completing a new frame for the next meter.

### **Raising the Mold:**

You attach the pulley rope to the rerod (triangular) support which is connected to the mold. Now apply tension to the rope and secure to the brake post.

Steps to follow for raising mold:

1. Break open mold by pulling out one door rod and pull till door opens.
2. Tap with hammer and daba head between top edge of mold and cement ring constantly pulling one section at a time until mold breaks from cement ring.
3. Raise mold above cement ring. Place 2 U-irons in proper position and lower mold onto them.
4. Add platform boards, and reassemble mold door.
5. Center mold with previous ring, and pour.

## **DEEPENING WELLS**

Why deepen?

It has been found that many hand dug wells (about 50%) go dry in the first year following their construction. They only become permanent sources

of water if they are deepened during the following well season. The main reason for this is that the volunteers have only buckets to bail the water out of the wells as they are working. Thus, when there is more than a meter and a half or two meters of water in the well, it is very difficult to bail it out to permit work to continue. At a certain point the volunteer must decide to continue and cement the well. The new well then contains about two meters of water, rarely more.

A new well causes a drop in the level of the water table immediately around it (this drop is called draw down). The water table also rises and falls every year in a cycle. It is at its lowest just before the rainy season begins. This means that a well that is finished early in the dry season is likely to go dry later, because the water table will drop lower than two meters between December and May. The well will thus have to be deepened at the end of the dry season during which it was built, or towards the end of the following one. Peace Corps and all agencies that dig wells in Upper Volta are therefore forced to deepen a large percentage of their wells.

Three techniques of deepening wells are explained. The first two (the ½ meter dig and pour, and the deja dug and pour) are used in fairly solid soil. The third (trousse coupante) is used in fluid soil. The trousse coupante is a new and improved method of working in fluid mud wells. In the past these wells have always posed a problem because there is no secure foundation for the concrete mold.

### **Dig ½ Meter, Pour ½ Meter**

#### **TOOLS:**

1. ½ meter mold
2. 2 pulleys
3. 2 ropes
4. 3 buckets, 1 large 2 small.
5. 1 trowel
6. 1 pick
7. 1 shovel
8. 1 measure
9. 1 hammer
10. 2 stocks, 60cm long 1-60cm long.
11. 1 rerod cutters.
12. 1 mining bar (if needed)
13. hard hats
14. old engine oil
15. pliers

### **Digging:**

Have the villagers dig down 60cm. It is best to cut a stick 60 cm in length and explain to them to dig until the stick fits between the cuvelage and the floor

of the well. The diameter must be a uniform 160cm and the best way to make sure it will be so, is to cut a stick 160cm and explain its function too.

### Placement of Rerod:

Verticals are cut to a length of 1 meter. 25cm is bent into an L-shape, while the other end is hooked into a small J-shape.

Horizontals are cut to a length of 5 meters and preshaped before placing in the well. They are placed 12½cm and 377½cm from the bottom of the well.

Place the verticals underneath the hanging rerod extending from the bottom of the last cuvelage. Bend the hanging rerod into hooks and wire together. See dia. Now, place the horizontals, at correct distances, and attach securely to the verticals. Remember the horizontals are nearest to the dirt wall.

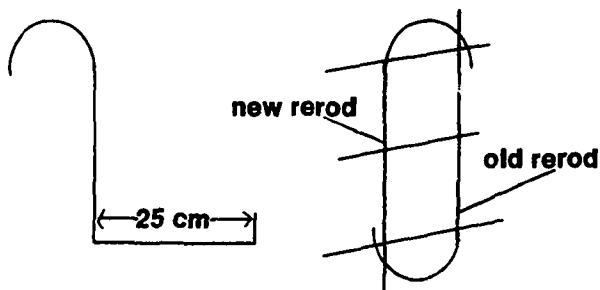

### Mold:

After the rerod frame is in place; lower the mold piece by piece into the well. Assemble in the well and oil. Then center the mold so that it follows the one on top of it, and level.

### Mixtures:

If you deepen and water is continually seeping, then remember to use a fairly dry mixture and not a wet one as you would for new wells. A stiff mixture of cement will be used to close the 10cm gap that was used as the opening to pour the cement into the mold.

### Pouring:

Concrete is poured directly into the space between the mold and the sides of the hole. There will only be a 10cm gap between the cuvelage last poured and the top of the ½ meter mold. A few buckets should be poured on one side and then the opposite side, continuing around the mold in this manner. This is done to prevent concrete from piling up on one side causing the mold to shift. Every so often, take the tamping rod and tamp the concrete to settle it and to eliminate air bubbles. Let this dry, then return and fill the gap.

### Second Day:

Have the villagers dig as before; set up your rerod frame. Attach a rope to the mold, using the same *lowering* method as the DIG AND POUR. Break open the mold and lower to the bottom. Mix concrete and pour. With this method you can deepen ½ meter a day.

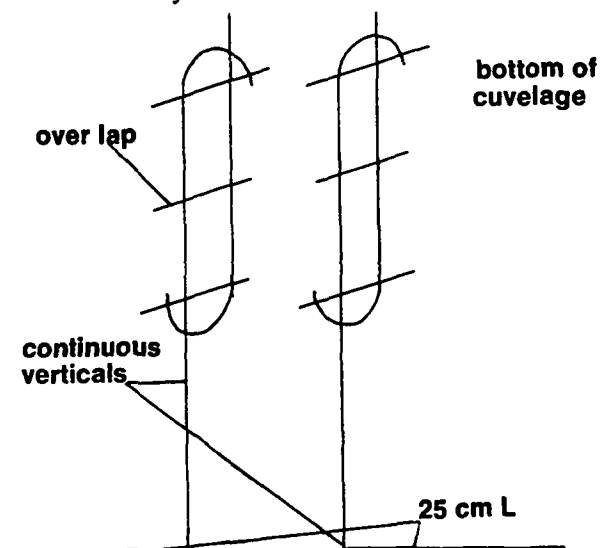

### Deja Dug, Pour:

This method is used when the villagers have already deepened one or two meters before you arrive.

### TOOLS:

Same as in the ½ meter method.

### ADD:

- 2 U-iron
- 2 Platform boards
- 1 sledge hammer

### Digging:

Make sure the diameter of the well is the proper distance, using the 160cm stick. As for the depth. One rule to remember: Leave a 10 or 15cm gap between the top of the mold and the bottom of the old cuvelage. Example: If the well has been deepened 1½ meters, then have the villagers dig down another 10 to 15cm so that there will be an opening to pour the final and third ½ meter cuvelage. Total depth of deepening will be 160 or 165cm instead of 150cm.

### Placement of Rerod:

A good method to use that was found to be efficient and time saving is to hang continuous verticals from the old cuvelage to the bottom of the well. Making sure you overlap the extending pieces of rerod from the old cuvelage to the new verticals, see dia: Also leave a 25cm L-bottom to continue deepening, if



necessary. Attach the horizontals to the verticals at the correct distances.

**Mold:**

After the reroed frame is in place, then lower the mold piece by piece into the well. Assemble and oil. Center the mold the best you can, and remeasure from bottom of well to the bottom of the old cavelage to make sure of proper distance.

**POURING AND MIXTURES:**

Same as in 1/2 meter method.

**Second Day:**

Break open the mold. Using the dig and pour 'raising' method, raise 1/2 meter and continue. When the last 1/2 meter has been poured, then fill the 10cm (plus or minus) gap.

Advantages to this method:

You have continuous verticals, stronger frame.

Only one 10cm gap to fill and it takes less time to deepen in this manner.

**TROUSSE COUPANTE WELL DEEPENING**

**Fluid Soil**

**TOOLS:**

1. 1 trousse coupante mold
2. 1 brick mold
3. 2 pulleys
4. 2 ropes
5. 3 buckets, 1 large, 2 small.
6. 1 masons trowel
7. 2 shovels
8. 1 measure
9. 1 pick
10. hard hats
11. reroed cutters
12. old engine oil
13. ladder
14. board and spike nails (Nevada form)
16. hammer.

**REROD FRAMEWORK FOR T.C.:**

The trousse coupante skeleton consists of the following:

30 nevada shaped pieces of reroed which are cut 82cm in length before bending.

2 interior reroed horizontals which are 346cm with a 30cm overlap. 2 exterior reroed horizontals which are 425cm in length with a 30cm overlap. 24 vertical reroeds of staggered length (about a meter), four in each of the six spaces between the bricks.

First, you make 30 Nevada shapes by bending a 82cm piece of reroed around nails pounded into a solid piece of board. Attach the overlap with wire. Spacing of nails are indicated below:

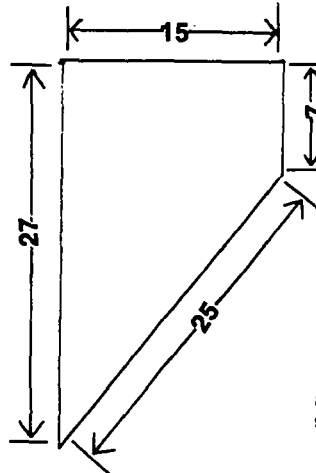

approximate spacing of nails.

The four circles of reroed can now be attached to the 30 Nevada shaped pieces. The 30 Nevadas should be equi-spaced.

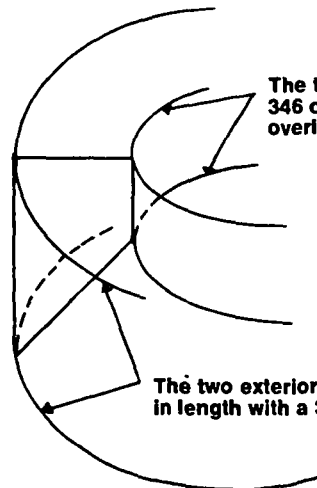

The two interior circles are spaced 346 cms. in length with a 30 cm. overlap.

The two exterior circles are 425 cms. in length with a 30 cm. overlap.

Once the framework is assembled, a half day's job in itself not including making the Nevadas, place a circle of six bricks on top of the framework to see where your holes will eventually be. Mark the spots with a crayon or by tying wire at each hole. Remove the bricks and attach the 24 verticals to the frame, four at each marked spot. It is best to stagger the lengths of the verticals. If all are at the same level with four more hooked to them, they will practically fill the hole at that point, making it difficult to pour the cement in. It is suggested that two of the verticals be cut at one meter and the other two be cut at about a meter and a half.

### **Trousse Coupante Bricks:**

Mixture: 4 sand, 1 cement

Make a large mixing platform that is in an area that will be shaded all day or construct a shelter over the platform. Also, a close water source would be best since the bricks must be cured for 5 days.

Oil the brick mold well before starting. Then assemble the mold with bolts.

Put in the four sand, one cement mixture making sure that it fills all the corners completely. Your hand makes a very good tamping rod. You will have to learn from experience how wet to make the mixture and how long to wait before removing the mold. You should be able to make about thirty bricks a day. The bricks can then be moved to a shady area where they will be watered (cured) twice a day, morning and night, for five days.

### **Busing:**

When you find the dig and pour method can no longer be used, then the trousse coupante should be inserted.

First you should make at least 144 bricks. This will make a column of about four meters.

Oil all sections of the mold before lowering. The interior section of the mold can be lowered in one piece and placed in the center of the well. This section should be lowered with no one in the well. Then, with a man in the well, lower the four pieces of the exterior section one at a time. Assemble these at the bottom and make sure the whole mold is level.

Next, lower the pre-fab framework into the well and fit into the mold.

You are now ready to pour the cement. It is a mixture of six buckets of sand, thirteen buckets of gravel, and one sack of cement.

Before the cement hardens, place one layer of bricks on the cement making sure the bricks are 3cm from the interior of the trousse coupante. They will not be flush with the outside of the trousse coupante. When bricks are added the outside should be flush (ie. each brick flush with the one above and below it on the outside).

All the above under busing can be done the first day. The second day, start by adding one meter of verticals to those existing. Then place four layers of bricks (24) again making sure no edges extend out past the outside edge of the buse. Now, fill the columns with cement in a mixture of 5 sand to 1 cement, or 4 sand to 1 small gravel and 1 cement. If the bricks are not perfectly formed, and they never will be, you may have to place small planks of wood

behind and in front of the bricks to form a mold to hold the cement mixture. Next, place two horizontal circles of rerod 3cm above the bricks, attaching it to the verticals with wire.

These horizontals may be 3.50 meters or 3.60 meters to allow adequate overlap. Put 6cm of mortar on the rerod (3cm above the rerod and 3cm below). While the cement is still soft but firm enough to support a layer of bricks, add a layer of bricks.

On the third and fourth day, the same above procedure is followed. The column is normally built to a height of about four meters before being sunk. At the top of the column, rerod should be left extending in case future deepening becomes necessary. Remember to bend the rerod over, so ropes will not catch on on them.

### **Sinking the Column:**

The first day is best used as a day of explanation, digging a bit and explaining to the digger where he must dig to level up the mold. The second day, place about a meter of very small gravel behind the column. Continue digging and hopefully sinking. Continue adding gravel and you may shim up the T.T.C. to keep it from tipping. Use small diameter sticks. Once the column has sunk so there is only ½ meter of overlap remaining, stop digging. Fill the space with gravel and place gravel in the bottom of the well up to the top of the trousse coupante. Pour a cement cover over this leaving plenty of holes in the cover.

### **Problems encountered:**

1. Mold will sink and is hard to keep level.
2. Bricks are hard to form flat level surfaces.
3. Ladder sinks continually.
4. Villagers do not understand about curing bricks.
5. Must work alone, not enough room for two people.
6. Once the column has tipped against the side of the well it is impossible or almost impossible to straighten.

## SAFETY

You have walked into this country in good health and if you made safety a part of your daily routine then you'll walk out in the same condition. Digging and pouring a well can be a simple, routine process if you think about safety in advance. Working at depth and then height with heavy materials makes all these tips important.

1. Make sure you use strong, straight (if possible), termite-free logs for your cross beams and posts.

2. If the logs are crooked, then lean them slightly away from the hole.

3. Set the posts at least 50 cm into the ground. Place a great many rocks around the posts in the holes and tamp them down. Better yet, dig a larger hole and set the posts in concrete. Do the same thing for the brake post.

4. Put an enclosure—either fence, thorns, bricks, low wall around the top of the well to keep animals, children, and objects away from the open hole.

5. Put a ring of banco bricks around the open hole 10 cm from the lip to keep stones from rolling into the hole while people are in the bottom. Later these same bricks will be the beginning of the wall for pouring the margelle. Also, the bricks for the margelle don't need mortar, they will stay in place for the pouring of the cement. The first layer does need it, however, or you will have a brick on someones head rather than just a rock.

6. Secure your cross beam to the up-rights with rerod wound once or twice around both.

7. Wire snap open pulleys closed. (French)

8. Reinforce old buckets with a re-rod cage.

9. Learn and teach a few boy scout knots.

10. Dry ropes at night by hanging on posts, and check them often.

11. Always wear hard hats in the well and be careful whenever you look up.

12. Use the large bucket when lowering, even one tool.

13. Do not pass tools across the top of the hole.

14. Use a safety line as the platform gets near the top. Line = rope.

15. Use the brake post when lowering someone. Also, have the people walk with the rope when pulling someone up. This is better on your rearend as well as your nerves, than the jerky hand over hand method.

16. Try to keep the children back when working. It's almost impossible but try.

17. Dolo, wells, and the midday heat do not mix.

18. When in doubt? GET OUT!

## MEASURES

The metric system, a short review.

|                |               |                    |
|----------------|---------------|--------------------|
| 10 millimeters | =1 centimeter | (cm)               |
| 10 centimeters | =1 decimeter  | (dm)               |
| 10 decimeters  | =1 meter      | (m) = 1000 mm      |
| 10 meters      | =1 dekameter  | (dam)              |
| 10 dekameters  | =1 hectometer | = 100 meters       |
| 10 hectometers | =1 kilometer  | (km) = 1000 meters |

1 inch = 2.54 cm    1 hectare = 2.471 acres

1 foot = 30.48 cm    1 liter = 1.056 liquid quarts

1 yard = 91.44 cm

1 mile = 1609.344 meters

1 acre = 0.405 hectare (ha)

1 centimeter = 0.3937 inches

1 meter = 39.37 inches

1 kilometer = 0.621 mile

## EQUIPMENT POUR LES PUIT

| Français                 | Moore        | Anglais               |
|--------------------------|--------------|-----------------------|
| Moule 1 mètre            | Mulli        | Mold—one meter        |
| Moule ½ mètre            |              | Mold—one half meter   |
| Moule à buse             | Bulug mulli  | Buse mold             |
| Moule à brique           | Tâkwem wamde | Brick mold            |
| Moule à trousse coupante |              | Trousse coupante mold |
| Grand seau               | So beddre    | Large bucket          |
| Seau italien             | So bila      | Cement bucket         |
| Pelle                    | Pelle        | Shovel                |
| Pioche                   | Pioche       | Pick-axe              |
| Barre à mine             | Baramine     | Mining bar            |
| Poulie américaine        |              | American pulley       |
| Poulie française         |              | French pulley         |
| Planche                  | rapeko       | Platform board        |
| Fer à U                  | Banga        | Platform U-iron       |
| Casque                   |              | Helmet                |
| Coupe boulons            |              | Rerod cutter          |
| Niveau                   |              | Level                 |
| Maillet en caoutchouc    |              | Rubber mallet         |
| Marteau de forgeron      | Marteau      | Sledge hammer         |
| Marteau de griffe        |              | Claw hammer           |
| Le scie à métaux         | Si à meto    | Hack saw              |
| Fût d'huile              | Barik        | Oil drum              |
| Pince universelle        | pêse         | Pliers                |
| Double mètres            | metre        | Tape measures         |
| Truelle                  | truelle      | Trowel                |
| Fil de fer               | bân bânega   | Wire                  |
| Corde                    | wirri        | Rope                  |
| Ficelle                  | gisga        | String                |
| Paire de griffes         |              | Rerod grips           |
| Plumb bob planche        |              | Plumb bob board       |

## FRENCH VOCABULARY FOR WELL DIGGING AND DRILLING

| English       | Français        |
|---------------|-----------------|
| well          | le puit         |
| water level   | la nappe        |
| shovel        | la pelle        |
| depth         | la profondeur   |
| pail          | le seau         |
| diameter      | le diamètre     |
| crowbar       | le baramine     |
| tape measure  | le double mètre |
| tripod        | le trépied      |
| concrete ring | la buse         |
| cable         | le câble        |
| wire          | le fil de fer   |
| rope          | la corde        |

**English**

hammer  
mold  
pipe  
nut  
concrete  
bolt  
pump  
crescent wrench  
auger  
screwdriver  
chain  
sieve  
side of well  
reinforcing rod  
top of well  
nail  
laborer  
cement  
mason  
rock  
reinforced cement  
granite  
construction site  
sand  
well-digger  
laterite  
water output  
rate  
mixture  
ring  
Fall  
waterfall  
failure  
balance sheet  
low-water mark  
pumping out of water  
digging  
wall  
lining, facing  
dress, attitude, holding  
sheet iron  
loophole  
flagstone  
water hole for animals  
slab to keep back mud  
sluice-gates  
(un moule)  
(abattage des roches par entailles  
parallèles aux couches  
notch  
cutting down of trees  
square shovel

**Français**

le marteau  
la moule  
le tuyau  
l'écrou  
le béton  
le boulon  
la pompe  
la clé à Mollette  
la sonde  
le tournevis  
la chaîne  
le tamis  
la cuvelage  
le fer de béton  
la margelle  
le clou  
le manoeuvre  
le ciment  
le maçon  
la roche  
le ciment armé  
le granit  
le chantier  
le sable  
le puisatier  
la latérite  
le débit  
le taux  
le mélange  
l'anneau  
la chute  
la chute d'eau  
un échec  
le bilan  
l'étiage  
l'exhaure  
la fouille  
la paroi  
le revêtement  
la tenue  
la tôle  
la barbacane  
la dalle  
un abreuvoir  
un antibourbier  
des vannes  
un mètre de coffrage  
  
le havage métallique  
l'entaille  
l'abattage  
la pelle carrée

**English**

pulley  
mixing basin  
rod cutter  
rule  
10-gallon can  
pick  
board  
string  
scraper  
shoring; propping; staying  
sheet iron  
flat bar  
cutting; cut; excavation  
line; plumb-bob  
cut-stone; building stone  
file  
bore hole  
boring; bore-hole;  
angle; iron square  
notch; nick; groove, slot  
ditch; canal  
coat of tar  
angle iron  
sheet; ironplating; sheet iron  
chisel; boring bit (drilling)  
chopping bit; chisel bit  
hack-saw blade  
to 1 box  
straight edge  
trowel  
chisel  
rod bender  
level  
hard hat  
windlass, winch  
string  
plumb-bob  
reinforced concrete  
pick  
round bar  
scaling-hammer  
cover; lid; cap  
mortar  
rush of water, waterflow  
drilling outfit  
axe  
hatchet  
coating; coat  
sheet steel  
bolt-hole  
winch  
handle (of a tool)

**Français**

la poulie  
la baignoire  
les ciseaux  
le mètre  
le pot  
le pic  
la planche  
la ficelle  
le grattoir  
étagage  
le fer en lame  
le fer plat  
déblai  
le fil à plomb  
les pierres de taille  
une lime  
coup de sonde  
le forage (sondage)  
la fee en équerre  
l'entaille (f)  
canal  
enduit de goudron  
fer cornière  
la tôle de fer  
le trépan  
le trépan à biseau  
la lame de scie à métaux  
la boîte à outils  
la règle  
la truelle  
le ciseau  
la clef  
le niveau  
le casque  
le treuil  
la corde  
le plomb  
béton armé  
la pioche  
le fer rond  
marteau à piqueur  
le couvercle  
le mortier  
coup d'eau  
équipement de sonde  
la hache  
hache à main  
enduit  
la tôle d'acier  
le trou de boulon  
la manivelle  
le manche

**English**

link; chain  
 hack-saw  
 tools  
 pulley

**Français**

le maillon  
 la scie à métaux  
 outils (m.pl.)  
 la poulie

**VERBS**

to toll (up)  
 to travel across  
 to run over  
 to undertake  
 to settle; to clear  
 to draw up; to set up  
 to pursue  
 to flow; to sink  
 to throw; to hurl  
 to require  
 to wind; coil; to wrap  
 to roll up  
 to notch; nick; groove  
 to pull  
 to discharge; to tip;  
 to shoot  
 to execute; to carry out  
 to bore; to drill  
 to tow; to pull  
 to turn over; to tumble  
 to sound out  
 to collide with; to strike against  
 to flow  
 to seal; to fill  
 to sink to the bottom  
 to throw oneself down  
 to deepen a well which does not give  
     enough water  
 to carry out a project  
 to pull a rope

rouler  
 parcourir  
  
 entreprendre  
 solder  
 dresser  
 poursuivre  
 couler  
 abattre  
 exiger  
 enrouler  
  
 entailler  
 tirer  
 déverser  
 faire couler  
 exécuter  
 forer  
 hâler  
 se rouler  
 sonder  
 se heurter  
 fluer  
 obturer  
 couler à fond  
 s'abattre  
 creuser un puits qui ne  
     donne pas assez d'eau  
 exécuter un projet  
 hâler un câble

# 5. SENEGAL, CEMENTING WITHOUT A MOLD PCVs Senegal

June 1972

|                                       | <u>Page</u> |
|---------------------------------------|-------------|
| I. Type of Well                       | 1           |
| II. Type of Soil                      | 1           |
| III. Goal of Program                  | 1           |
| IV. History of Program                | 1           |
| V. Relations with the Government      | 1           |
| VI. Other Aid Available               | 2           |
| VII. Materials Needed                 | 2           |
| A. Tools                              | 2           |
| B. Material Estimates                 | 3           |
| VIII. Choosing and Preparing the Site | 3           |
| IX. Organization of Digging Team      | 3           |
| X. Making the Well Walls              | 3           |
| A. Preparing the pulley mount         | 3           |
| B. Plumb                              | 4           |
| C. The First Meter                    | 4           |
| 1. Digging                            | 4           |
| 2. Re-rod Preparation                 | 5           |
| 3. First Plaster Coat                 | 6           |
| 4. Placing the Rerod                  | 6           |
| 5. Second Plaster Coat                | 6           |
| 6. Keeping the Plaster Wet            | 6           |
| D. All Additional Sections            | 7           |
| 1. Digging                            | 7           |
| 2. Rerod Preparation                  | 7           |
| 3. First Plaster Coat                 | 8           |
| 4. Placing the Iron                   | 8           |
| 5. Second Plaster Coat                | 8           |



|  | <u>Page</u> |
|--|-------------|
| E. Final Section of Shaft              | 8           |
| 1. Stopping above the water level      | 8           |
| 2. Alternative method                  | 8           |
| XI. The Casings                        | 10          |
| A. Building the Casings                | 10          |
| 1. Preparing the Mold                  | 10          |
| 2. First Coat of Plaster               | 10          |
| 3. The Iron                            | 11          |
| 4. Second Plaster Coat                 | 11          |
| 5. Perforations                        | 11          |
| 6. The Lowering Hooks                  | 12          |
| 7. Watering and Digging the Casing     | 12          |
| B. Emplacing the Casing                |             |
| 1. Lowering the Casing into the Well   | 12          |
| 2. Fixing the Casing into Place        | 13          |
| 3. Joining the Last Casing to the Wall | 13          |
| XII. Covering for the Well Bottom      | 14          |
| XIV. The Apron                         | 14          |
| XV. The Well Wall                      | 15          |
| XVI. Covering the Well                 | 15          |
| XVII. Safety                           | 16          |

## SENEGAL

- I. Type of Well: Hand-dug, 2-meter inside diameter, walls of plaster reinforced with rerod, casings of same materials formed at top of well and lowered into position.
- II. Type of Soil: Predominantly sand with occasional pockets of laterite.
- III. Goal of Program: To dig durable wells as efficiently as possible while using only those tools which are readily available in the local community. The hope is that villagers working with the Volunteer can learn the method and subsequently build other wells on their own.
- IV. History of Program: An evolution of program goals in Senegal has brought the focus on to village animation. The Volunteer lives in a single village and attempts to structure responses to the needs of that village as well as outlying villages. The recent Volunteers, therefore, have not been specialists in wells or gardening or latrines or health, but rather they have worked in any and all of those fields. (This approach corresponds precisely with the directives of the PC's official government contact, the Direction d'Animation Rurale within the Ministry of Rural Development.) The experience of these Volunteers yielded a program revision which called for the placement of 3 or 4 Volunteers in relatively close proximity so that they might support one another in various projects as well as make more efficient use of available Peace Corps tools and vehicles. The anticipated opportunity for specialization of individuals within these teams makes the evolution of a "well-digging team" more possible, than it had been during the previous system. Still, the following technique is adapted to use by a group of villagers instructed by a single PCV or experienced village mason.
- V. Relations to the Government: Owing to an ongoing restructuring of the Senegalese local administrative offices, it is difficult to say exactly what the PCV's relationship to the government actually is. At present the Volunteer has official ties with the Chief of Rural Expansion (for the arrondissement) with the Chief of Animation (for the department) and with the Prefet (the top administrator of the department). Functional relations depend on the particular bureaucrats and Volunteer in question. As a general rule, the Volunteer informs all interested government offices so as to avoid government resistance or interference. In the specific case of well-digging, this means that many and perhaps most of the PC-built wells are planned and constructed without any government involvement. There have been, however, cases when the prefet has donated cement and rerod, while in other cases, the Animation office has provided transportation of construction materials. On the other hand, the official well-digging and well-repairing crew of the government has no effective interchange with the Peace Corps. In sum, the government neither

dictates the location of wells built by the PC, nor can it be counted on to aid in the building of these wells.

- VI. Other Aid Available: The U.S. Embassy Self-Help Fund will contribute to the cost of building/improving a well if it can be demonstrated that the well will serve the development of the village and that the villagers will participate in the costs and/or labor involved in the construction of the well.

Catholic Relief Services will receive applications for aid in purchasing of well-building materials and for the purchase of pumps for well conversion. Again, specific project criteria must be met in order to qualify for this aid.

The Peace Corps can provide on a loan basis all tools required and a pick-up truck for hauling the building materials, including sand, laterite, cement, and rerod.

VII. Materials Needed:

A. Recommended list of tools -

- 6 shovels (some with short handles)
- 4 trowels
- 1 mason's hammer
- 1 pair of wire cutters for reinforcing rod
- 1 folding ruler
- 40 m. of strong rope (5/8" or 3/4")
- 2 pulleys
- 1 rerod bending tool (griffe)
- 1 metal hook for end of rope
- 2 small buckets
- 2 large buckets (10-15 gallons)
- 2 centering planks
- 1 plumb bob
- 1 scraper attached to length of chain (scraper = L-shaped piece of metal)
- 1 perforating tool
- 1 wheelbarrow
- hard hats
- 1 first-aid kit
- 1 daba (native digging tool similar to a short, stout hoe)

## B. Material Estimates -

Once the approximate depth of the well is estimated, the costing can be done with the following guides (calculated for a 2m. diameter well):

For each one meter section of well shaft:

5 sacks of cement  
80 m. of iron rerod

For each casing of height 50 cm.:

$2\frac{1}{2}$  - 3 sacks of cement  
56 m. of rerod

One roll of wire to tie the intersections of the rerod. The final materials estimate should be increased 10% to allow for waste.

## VIII. Choosing and Preparing the Site:

The site should be carefully chosen. It should be at least 20 m. from the nearest latrine or other source of contamination and located on higher ground. Areas known to contain rock layers should be avoided if possible. An area of about five meters in all directions from the well site should be cleared of brush.

## IX. Organization of Digging Team:

The Volunteer will have discussed the well with the village leaders and they will have reached an agreement as to the material costs and the labor. Some villages may provide a pair of skilled masons who will stay with the project until completion. Other villages may provide only random pairs of men who neither have the desired skills nor will stay with the work long enough to learn these skills. Hence, the Volunteer must be prepared to carry the burden of technical expertise. Depending on the particular situation, he may elect to do most of the skilled labor and finish the well quickly, or he may wish to move more slowly thereby having the chance to train the villagers who assist him.

## X. Making the Well Walls:

- A. Preparing the pulley mount: Erect two forked logs with "Y" pointing upwards, about 3.20 meters apart (60 cm. beyond each edge of the proposed well wall). These logs would ideally extend about 2 meters above the ground. A strong cross-beam capable of supporting two or

three hundred kilograms should be placed across the forks of these logs. The pulley can then be bound to the center of this cross-beam by using two or three coils of 5 mm or 6 mm rerod. The two vertical pieces may be planted in cement if this is needed for stability.

- B. Plumb: Keeping the well plumb is important for minimizing the stress on the walls. To this end a plumb-bob and centering board are employed. A few days prior to starting the digging of the well, make two holes 30 cm. deep and 20 cm. in diameter - about 3.50 m. apart and centered over the proposed center of the well. Place a piece of straight rerod in each of these holes and then fill the holes with concrete, being careful that the rerod pieces are standing vertically with about 20 cm. protruding above ground level. A straight long plank of about 3.60 meters is secured. Holes are drilled at each end to accept the two pieces of rerod when the plank is laid over the proposed well site. Precisely midway between these two holes is drilled another hole of diameter large enough to receive a  $\frac{1}{2}$ " metal pipe or other straight, rigid bar. The plank may then be removed and replaced on the rerod guides so as to facilitate work in the well without losing the means of determining the exact center of the well.

C. The first meter of the shaft:

1. Digging: The hole will be dug to a 214 cm diameter in order to allow 7 cm. walls and a 3 m. inside diameter. A circle of 1 m. radius from the center will be traced and the digging begun in such a way that the 214 cm. diameter will nowhere be exceeded. Once this hole is about 1.10 m deep, the centering board is emplaced and a plumb-bob point is marked in the sand. The rod is now placed through the centering hole and the chain with L-shaped iron scraper is fastened around the rod. The bottom end of the rod is then driven into the sand at precisely the plumb point.

The chain and scraper (which were pre-measured and tied so as to have a radius of exactly 1.07 m.) are now ready to finish the hole. In some cases the soil is so sandy that the smoothing can be finished with the scraper itself. In other cases, digging tools must be utilized while the scraper serves only to indicate the proper radius. It is important that the chain length be left unchanged once the digging has begun.

The walls are double-checked with a level and any excess is trimmed. Then the top of the well is carefully levelled. When the digging is terminated a paint made by dissolving 1/4 bucket of cement in a bucket of water should be splashed on all surfaces to be plastered. This cement coating makes it easier for the plaster to cling to the sides. In addition, if the plastering cannot be done the same day as the digging, the cement paint will keep the sand from drying out.

2. Re-rod preparation: The iron rerod should now be prepared. In sandy soil, rerod should be placed 15-20 cm. apart. (In clay 25 cm. and hard clay or laterite 30 cm.) For a 2 m. in diameter well, this means at least 32 vertical rods in sandy soil. For the first meter, the vertical pieces should be 135 cm. long. This includes 30 cm. which extends at right angles over the lip (so as to be tied on to the rod of the apron which will be constructed later), 100 cm. for the section to be plastered plus about 5 cm. for a small hook at the very end of the vertical piece. Care must be taken to eliminate bends and bumps in these straight lengths in order that the rerod lie flush to the plaster when placed.

There are two designs for laying the horizontal pieces. If the rerod is No. 5 (which comes in rolls) a single spiral piece may be laid continuously until 20 cm. - distant laterals - have been formed throughout the height of the section to be plastered. When 6 mm rerod is used, a series of individual horizontal bars must be employed. The number of horizontal bars per meter varies with soil types; 5 or 6 are most frequently employed. (This technique may also be used with 5 mm rerod if one wishes.) For a 2m. well, each of these five pieces should be at least 6.5 m. long, with about 15 cm. being bent at right angles to the rest of the length. In addition, pieces of rerod about 20 cm long are curved into a U-shape so as to serve as tacks whenever the horizontal rerod does not lie smoothly in place. Twenty or more of these staples may be required per meter section. It is important to allow for this quantity in estimating the rod to be purchased. (It has been suggested that a 30 cm. overlap of the vertical rerod pieces with 3 wire ties on the overlap would greatly increase the vertical strength of the wall. After consideration of this suggestion, the PCVs acquainted with well building have decided not to make this alteration in the technique used in

Senegal. Cost considerations enter into the picture in that the amount of rerod required per meter of well would be increased by about 10-15%. That, plus the fact that no well has yet been observed to fail because of unsupportable vertical stress, dictates the decision to continue the old technique of simply hanging the hooks of each meter's rerod directly on the hooks protruding below the plaster of the previous meter.)

3. First plaster coat: A mortar (3 parts sand to 1 of cement) is prepared. If the cement paint has dried out, it should be re-moistened and then the first plaster layer is applied with a trowel. It should be at least 3 cm. thick, and uniform all the way around. It should start about 5 cm. over the lip of the well and continue 1.00 m. down into the well.
4. Placing the rerod: When this plaster coat has been completed, the horizontal rerods may be fixed into position. Assuming 5 pieces are to be used, they should be placed about 10 cm., 30 cm., 50 cm., 70 cm., and 90 cm., from the top of the well. The 15 cm. right angle section should be pushed directly out into the well wall. Then one person should progressively guide the rerod into place as another worker standing beside him encourages the rerod into place by tapping its unfixed end gently but steadily with a hammer. The staples can be used when the horizontals otherwise refuse to lie flush against the wall. A staple is used to anchor the free end of each horizontal once the whole piece is properly placed. After all horizontals are placed, the proper spacing for the vertical rerods should be marked in the plaster of the lip. The verticals can then be placed in their positions with the 30 cm. right angle section extending rapidly out over the lip. Whenever the verticals do not lie flush against the plaster, the rerod bending tool should be used to bend them into position. After all verticals are emplaced, each of the horizontal-vertical intersections is wired together, thereby creating a unified cage of rerod for that section of the well.
5. Second plaster coat: Another coat of at least 3 cm. immediately after the iron is ready. The first coat of plaster will still be wet and thus the two coats and rerod will form a single, reinforced, plaster wall. After the second coat is applied, the walls should be checked for recesses and bumps with a

straightedge. Once the well has been found plumb, a third, thinner coat of plaster may be applied in order to make the walls as smooth as possible. This smoothness helps to minimize wear on ropes, buckets and walls. Care should be taken to see that the hooks of all of the vertical rods stick far enough below the plaster that the next set of verticals may be properly hung.

6. Keeping the plaster wet: The plaster should be wetted down for at least 3 (preferably 5) days while it is curing.

D. All additional sections: There is no reason why a section need be constrained to a single meter. It takes two good workers about three hours to plaster one meter and  $4\frac{1}{2}$  hours to do 2 m. Depending on the amount of work time available, the well should be dug and the rerod cut accordingly. From the second section on, the workers and materials will have to be lowered by a pulley and rope and soil shall be evacuated by the same system. A bowline knot must always be used for lowering objects and people into the well. The Volunteer should take steps to be sure of every knot tied for that purpose. Care should be taken to be sure that no confusion exists in the minds of the villagers as to what procedures and signals are for the operation of the ropes, buckets, etc.:

1. The hole is dug as before to a radius of about 1 m. and to a depth of about 110 cm. below the hooks of the emplaced vertical rods. The centering board is positioned and the plumb-bob is suspended and the well center is marked at the bottom. The centering rod, with the scraper and chain in place is driven into the mark. The plumb-bob is hoisted to the level of the top of the centering rod and the rod is tied into a plumb position with ropes connecting the top of the centering rod with four opposing hooks of the rerod placed in the previous meter section. This positioning of the center rod must be done accurately and securely so that the scraper describes the surface of a cylinder which is perfectly plumb with the previous sections. After scraping, the sides are again double-checked with a level and needed alterations are completed.

2. The rerod preparation: The rerod preparation for the horizontal sections is exactly the same as that described for the first meter. The verticals are different only in that they are 110 cm. pieces, composed of a 100 cm. straight piece and a 5 cm. hook on



each end. There will be a need for staples for these meter segments just as in the first meter: to hold the horizontals.

3. First plaster coat: First of all, the cement paint should be applied to the walls. Then the first plaster coat itself is placed just as it was in the first meter section, save for the extra care needed to plaster behind the protruding ends of the rerod of the previous section.
4. Placing the iron: The horizontals should be placed as in the first meter, either a continuous spiral or separate horizontal hoops. The verticals should be hung on the uncovered hooks of the verticals immediately above, in such a manner that they are plumb. All rerod intersections should then be wired securely to insure the solidity of the rerod cage for that meter.
5. Second plaster coat: Exactly the same procedure as for the second coat of the first meter, except for the absence of the well lip.

E. Final section:

1. Once water has been reached the normal method of digging is no longer employable. The last section of the 2 m. diameter shaft should be cut off just above the water level and all other procedures followed as in previous sections. The only change is that the rerod will not need to extend below the plaster, but rather will be cut short so that the plaster will entirely cover it.
2. An alternative method for constructing the section below the water table is available. The constraints are three: the availability of ciment fondu, a French quick-drying cement; the additional money required to purchase the expensive ciment fondu; the rate at which the water flows through the sand and into the well. Since well casings are inherently weaker than the well shaft, this method is structurally superior to stopping the shaft at the water level and continuing therebelow with casings. The increased cost is a factor because about two sacks of ciment fondu (about \$9. per sack at Senegal-1970 prices) will be required along with four sacks of regular cement for every meter section. Nonetheless this method is preferred.

Since there will be water flowing into the well while the plastering is in progress, special procedures are required. Someone will have to be pulling the water from the well at all times. Digging will be conducted at a more gradual pace and plastering will be done immediately after an arc of a 30 cm. deep section has been dug and roughly plumbed and smoothed. Special bricks are made for the purpose of covering places where water is coming through the sand too quickly to permit plastering. These bricks are made outside the well by spreading a  $1\frac{1}{2}$  cm. layer of plaster on a flat surface, and then cutting the plaster into 15 cm x 15 cm. squares with the edge of a trowel before the plaster dries. Rerod is the same for the horizontals as in the earlier sections, but the verticals are shortened to 40 cm. overall, 30 cm. straight and 5 cm. for the hooks on each end. The mixing ratio is 1 part ciment fondu to 2 parts ordinary cement and 1 part sand. A dry mixture can be prepared beforehand and small quantities wetted as needed.

If this procedure is to be used, the vertical rerod of the last normal section must be allowed to extend below the plaster, just as in the previous shaft sections. The procedure begins by digging in the center of the well until an inverted cone 40 cm. deep in the center and slanted to the bottom of the previous plastered section is formed. (This method keeps sand from washing out from behind the sections already plastered.) Then a short arc along one side is quickly dug down to a depth of 30 cm; it is roughly plumbed and smoothed. Dry ciment fondu cement-sand mix is thrown by handfuls on to the moist, slowly collapsing sand. Then small quantities of the mixture are moistened and quickly plastered onto the arc. Owing to the rapid setting of this mortar (about 5 minutes) the plaster will harden before the water flow causes it to collapse. Whenever an arc contains a spot where the water flow is so rapid that it erodes even the rapid setting mix, a brick can be used as a stopper. Dry mix is thrown freely on the place where the water is entering and a flat brick is slapped on and held in place until the cement sets. The brick can then be plastered over in the same manner as for the rest of the arc. Once the first arc has been plastered, another arc is dug and plastered in the same way. When all of the arcs of the 30 cm section are completed, the re-rod is placed and plastered over with the same mix. Subsequent sections are built in the same way until the desirable penetration into the water table is achieved or until the water flowing into the well prevents further plastering.

## XI. The Casings:

Because the casings will take at least five days to cure after they are made, they should be started a week before their use is required. The number of casings to be used for each well will vary depending on whether water can be evacuated quickly enough to allow digging to proceed below the static water level. In all cases, at least four casings or "buses" each of height 50 cm. should be sunk. (Fewer casings may be required if the alternative technique described in X.E.2., has been successfully used to continue the shaft below the static water level.) The width of these casings can be as great as 1.85 m. so long as no bulges or turns in the well wall will prohibit their passage to the bottom. Careful measurements must be taken so that whatever size is decided upon will pass through the shaft without problem. When making this calculation include the additional width of the tip of the casing (an extra 5 cm. onto the diameter of the casing).

It is suggested that the first casing of a series in a clay-sand soil be flared at the bottom. This will keep clay from sticking to the sides of the casings in such a way as to impede the sinking into place of the casings. In all cases, the top of each casing should be wider so as to increase the area on which mortar can be placed during the joining of one casing to the next. In the case where the casing is 185 cm. in diameter, this lip would extend to a diameter of about 190 cm. One must be exceedingly careful to see that each casing is shaped so as to fit properly on the preceding casing.

### A. Building the Casings:

1. Preparing the mold: Set up a smaller version of the centering board which was used for the well-shaft. Two vertical rerod pieces are implanted about 2.50 m. apart. A straight plank has a hole to receive one of the rerod pieces bored at each end; the guide hole is then bored precisely between the two holes. This guide hole will accept the  $\frac{1}{2}$ " pipe or other centering post utilized. The chain with scraper are set for a radius of 92.5 cm (or whatever is required to yield the proper outside diameter) and that circle is drawn on the earth. The guide system is removed and a rough hole is dug to a depth of 60-70 cm. The guide plank is replaced, the center of the hole is found with a plumb-bob, and the center rod, with chain and scraper attached, is fixed in place. After the walls are scraped they are double checked with a level. Then the top of the hole is levelled and smoothed.
2. First coat of plaster: The cement paint is again mixed and splashed on the walls. The mortar is mixed ( $2\frac{1}{2}$  parts sand to

each part cement). It is then applied just as in the well shaft, the thickness being 3 cm. The coat starts about 3 cm. over the lip and extends down a bit over 50 cm. into the hole.

3. The iron: Vertical rerods are cut 52 cm. long, with 2 or 3 cm. being bent into a small right-angle hook. There should be enough to have one vertical every 15 cm. around the circumference; in this case, about 38 of them will be required. The horizontals should complete the 15 cm. sided squares. Either the spiral (for 5 mm) or the 4 independent horizontals (for 5 mm or 6 mm.) can be used. Individual horizontals should be about 6 m. long, including the 15 cm. section to be bent at right angles to the length. A few small staples should be prepared. Eight lowering hooks should be prepared, each formed from a piece of rerod about 60 cm long which has been bent into a U which is about 15 cm. across at the open end.

The horizontals are placed first, at levels of about 5 cm., 18 cm., and 45 cm., below the lip. The same technique as for the well shaft is used except that special care is taken to minimize the number of staples used, since they will all have to be cut off later. The verticals are then hung at the proper spacing and with their 2-3 cm. hooks extending over the casing lip. Each of the rerod intersections is then tied with wire.

4. Second plaster coat: The second layer is then added in the same manner as the second coat in the well-shaft. After it is smoothed and checked for level, the lip is trimmed to a uniform  $2-2\frac{1}{2}$  cm. width. The top of the casing is checked for level and necessary adjustments are made. The bottom of the casing is then cut at precisely 50 cm. below the top of the casing, with the result that the bottom, too, is level. Not only must the top and the bottom of the casing be level, they must also be thick enough to be strong. (A frequently observed problem in such wells is that sand leaks in through broken portions of the tops or bottoms of the casings.)
5. Perforations: Before the plaster is dry, but after it has set up, a tool or piece of rerod is used to punch holes in the casing. These holes are intended to allow water to enter more easily into the casing; there should be a minimum of 100 of them per casing. An improved technique is to poke the holes on a slant so that the outside opening of a hole is below the inside opening of the same hole; this grade is designed to impede the entry of sand into the well while leaving the flow of water undiminished.

6. The Lowering Hooks: An essential final step is to implant the 8 hooks which will serve in the lowering of the casing. They are installed in pairs - one 15 cm vertically above its partner - and the four pairs located at 90° from one another. The open ends of the "U"s are pushed through the plaster and into the earth until about 7 cm of the hook remains visible inside the hole.
7. Watering and digging the casing: The casing should be wetted down frequently - every few hours - for at least 5 days. Failure to water sufficiently will yield general weakness and perhaps cracks which will later hasten the crumbling of the casing.

The soil outside the casing is then dug away. The ends of the lowering hooks outside the casing are bent flat so that the hooks will not pull loose during the lowering operation. The ends of any staples used are cut off. All dirt is scraped free from the outer side of the casing and plaster is used to cover all iron on the outside of the casing. Then, with a fairly large number of men (about 10) the casing is lifted from the hole and carried to the well where it is rested on two planks which have been laid across the top of the well. Levers should be avoided in lifting and moving the casing because they put undue stress on the top and bottom rims.

B. Emplacing the casing:

1. Lowering the casing into the well: The casing is centered above the well. Two pulleys are attached to the crossbar suspended above the well in such a way that they are each above one side of the casing. Two strong ropes (5/8" or 3/4", without flaws) are prepared. Each rope is passed through one of the pulleys and then down to the lowering hooks. The rope passes first down through a top hook, then down through the hook directly below the first, then over to and up through the bottom one of the adjacent pair, and subsequently up through the top one and back to meet the rope again. This loop is secured with a bowline knot. The other rope is similarly looped through the remaining two pairs of lowering hooks.

Two teams of men are formed, each with a minimum of 6 or 7 men. A coordinator who has decided upon and made known a set of clear instructions, stands at the well site to observe and direct the progress of the descending casing. He instructs both teams to lift the casing slightly and, if it is well centered and hangs well on the ropes, he removes the 2 cross pieces that had been supporting the casing. The coordinator instructs the

men to begin lowering the casing and makes certain that the rate of descent is slow and that the casing stays away from the well walls.

2. Fixing the casing into place: When the casing has reached the bottom someone must go down the ropes and check its placement. If it is the first casing it must be sitting equidistant from the walls and must be level. (A casing sitting out of level will sink crookedly). If it is not the first casing, it must sit directly atop the previous casing in such a way that the lowering hooks are directly above those of the previous casing. Prior to lowering the new casing a rim of mortar (ratio 2 parts sand to 1 cement) is placed atop the casing already in the well. Once the new casing is in place this mortar is smoothed into a seal with a trowel. The inferior lowering hooks are then attached with lengths of rerod to the superior hooks of the preceding casing. The hooks are then bent flush to the wall so as to minimize the chance of tangling ropes and buckets. The superior hooks are left extended unless the casing is the last one, in which case they, too, are flattened against the sides. All rerods which have been bent into final position should be plastered over in order to keep from rusting. Once the casing is properly fixed, gravel should be placed around the outside of the casing. This will keep sand from falling as the sand is dug and the casing settles. In addition to making the digging and sinking easier, it will later act as a filter and inhibit sand from entering into the well or clogging the openings of the casing. (Laterite is not recommended for this use because it disintegrates over time. Seashells can serve this purpose but the well should be chemically decontaminated before use. Hard laterite can be used if nothing else can be found.)

Now teams of men may start to dig sand out of the center of the hole. As the sand at the sides of the hole sinks into the hole, the casing will settle. Care must be taken to see that all sides sink evenly; if one side is higher, additional sand should be taken from that side until the casing returns to level. If the casing is not to be the last one, the digging should continue until about 20-25 cm. of the casing remains above water. The process is then repeated for the next casing and all subsequent casings.

3. Joining the last casing to the wall: When the last possible casing has been sunk into place, gravel is added to fill all of the space behind the casings. Then a plaster cap is placed from

This area should be dug out to a depth of about 10 cm. Gravel (or laterite or shells) should be placed into the hole leaving a depth of about 6 cm. at the outside, and sloping upwards to the lip of the well. (The 30 cm. extensions of the rerod of the first meter will be connected to the rerod of the apron so they should be kept above the gravel foundation.) After the gravel has been tamped into a solid foundation, the concrete (1: 2: 3:) can be mixed and a 3 cm. layer poured and smoothed into place. Then the radial rerod should be placed. (The radial rerod should be of adequate length to extend the width of the apron. They should be of the same number as were the verticals in the well shaft. A small hook should be bent for the inside end of the 30 cm. piece extending from the well wall.) The hooks can simply be linked or the rerod may be overlapped and tied. The radial rerod, of course, is laid pointing straight outwards. The concentric pieces can then be cut, bent and placed so as to form a series of concentric circles 15 cm. from one another. All of the rerod intersections should be tied. As soon as the rerod is prepared the second layer of concrete can be poured and the surface of the apron can be trowelled to a finish. (The apron may more easily be done in 2 or 3 sections if mixing large quantities of concrete is difficult.)

#### XIV. The well wall:

This can easily be built of bricks and then plastered to a smooth finish. No special technique is necessary except caution when plastering the inside of the brick wall. The height can be from 50 cm. to 1 meter; the goal being to prevent small children and dirt from falling into the well, while not impeding easy use of the well.

#### XV. Covering the well:

In order to guard against well contamination, a reinforced concrete cover can be made for the top of the well. Two designs are frequently employed. One has an opening of adequate size and bolts properly placed to allow the mounting of a pump, plus a manhole to permit disinfection of the well and entry for repairing the pump cylinder inside the well. Another design has one or two openings with a lip on each opening and a cover that fits and seals into the lip. These holes are arranged so that a hand-drawn (with or without pulley) bucket can easily be used.

Whatever the design, such covers should be the same diameter as the outside of the well wall. The cover should be thick (8-10 cm.) and reinforced with rerod. Because of their weight, they should be cast in two halves in order to facilitate handling. The mold may be dug into

the rim of the casing, over the gravel and up to the well wall. This cap, built at an angle of  $45^{\circ}$  slanting down into the well, lessens the wear on buckets and casings when the buckets strike against this surface on the way down. In addition, the cap eliminates the chance of the water stagnating in the gap between the top of the last casing and the shaft wall. The cap also stops sand from being carried over the casings and into the well when the water table rises during the rainy season.

## XII. The covering for the well bottom

In order to keep sand from coming up into the well, a heavy porous covering should be placed on the well bottom, inside the bottom casing. A layer of gravel 20 cm. deep will suffice although a perforated concrete plate placed on top of a 10-15 cm. layer of gravel is a bit better.

The plate is made in two halves for easier placement. The overall diameter should be a few centimeters smaller than that of the inside of the casings.

A circle of proper dimensions is drawn on the earth, and it is dug out to a depth of 6 centimeters. A divider is placed down the middle of this mold and 6 mm iron is cut into lengths which will form a cross pattern with squares of about 20 cm. per side. The bottom of the mold is dampened in order to keep the ground from taking moisture out of the concrete too quickly. The concrete is mixed (1 part cement; 2 sand; 3 gravel) and a 3 cm. coat is poured in both halves of the mold. The iron is then placed in the pattern and the intersections are tied. Four lowering hooks are fixed under the mesh; two hooks for each half of the mold. Then the second layer of concrete is added and troweled to a smooth finish. When the concrete has set up, holes are made in the concrete with a piece of rerod or tool of similar dimension. The plate should be watered often for about a week. It can then be dug free, cleaned off and carried to the well. After the 10-15 cm. layer of gravel has been paid on the well bottom, the 2 plate halves can be lowered with ropes and pulleys and set into place (no mortar is used).

## XIII. The apron

An apron extending at least one meter out from the well should be built. This will keep mud from forming in the area next to the well where the water drawers stand. It will also greatly lessen the chances of contaminated water seeping back into the well. This area should be built of reinforced concrete (at least 6 cm. thick) and should slope away from the well.



the ground and a wooden divider inserted down the center of the cover. Then the layout of the holes should be decided upon and wooden forms (and pump bolts) should be made and placed accordingly. 8 mm rerod should be cut in length which will make a criss-cross pattern which forms 20 cm. squares. (6 mm rerod can be used if 8 mm is unavailable, but the squares should then be 15 cm. on a side.) The mold should be watered and the first half filled with concrete (1; 2: 3:). The rerod can then be laid into place and wired at its intersections. The second layer of concrete can then be poured and smoothed. The covers required for the holes can be poured (with rerod or the like for handles) into wooden forms or a mold carefully dug in the ground. Another technique is to wait until the concrete of the cover has set and then line the hole(s) with newspaper, plastic or other material in order to turn it into a mold. Side boards will still be required to form the sealing lip; nonetheless this technique is easier than making a special form and it ensures a proper fit.

The cover should be watered as it cures over about a five-day period. Then it can be dug free, lifted and the dirt scraped loose from its underside. A thick coat of mortar is placed on top of the well wall and the halves of the cover are set into place. All gaps in the mortar and the space between the cover halves are filled with mortar and then the mortar is trowelled to a smooth seal.

#### XVI. Safety

In all phases of construction curious children and other on-lookers must be kept clear of the work area. A well under construction is particularly hazardous because there is no protecting wall. Tools should never be left near the edges of the shaft because of the chance that they might be carelessly kicked into the well and on to the workers at the bottom. Before buckets or tools are lowered, those working below must be warned. All ropes and knots must be checked before they are to bear weight. Pieces of rerod protruding from the ground (such as those used to anchor the centering board) should be covered with tin cans as they are potentially very dangerous. Hard hats should be obligatory below the three meter level.

PLEASE BE EXTREMELY CAREFUL AT ALL TIMES.

## ADDENDUM

A recent suggestion has just been noted. It concerns the making of the well cover. Early efforts which employed the technique suggested in the formal description have frequently had problems with the breaking of the cover. The problem is that the piercing of a hole for the pump or the manhole, etc., diminishes the structural strength of the cover. Particular stress exists in the fairly small section between the hole and the flat edge of the cover-half. A change in the rerod pattern has been successfully used, along with a greater thickness of concrete, to combat this stress.

The change amounts to reinforcing around the hold just as if it were a window: i.e., each of the sides of the hole has a set of 4 rerod lengths held in the form of a rectangular solid "cage" by pieces of rerod bent into squares. (The long rerod pieces are tied with wire at the inside of the four corners of these squares.) One long cage is laid between the hole and the flat side. Another cage perpendicular to the long one, is run on each side of the cover-half). These cages should be 6-7 cm. to a side and long enough to fit into the mold and connect together to form one series of re-rod. The depth of concrete should be 9-10 cm. The weight is great and the rerod more difficult to work but the strength is greatly increased. Note that this set of cages is sufficiently strong to eliminate the need for further rerod in any other areas of the cover-half.

]

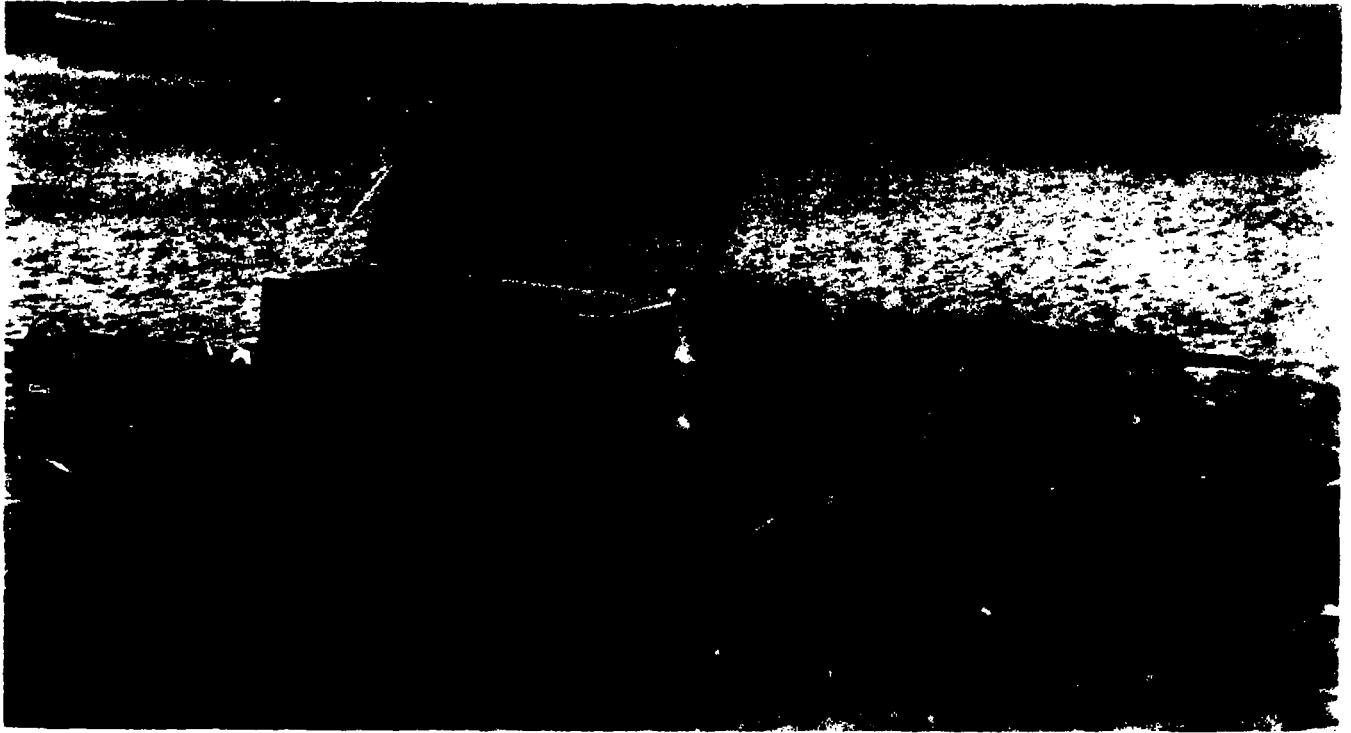

*PREPARING TOOLS BEFOREHAND* *Transportable storage box*



*PREPARING THE CENTERING BOARD*  
*Placement of verticle re-rod guide post*



*FIXING* *scraper at proper radius so that*  
*it will discribe a circle of the desired diameter*



*TRIMMING to precise diameter with the scraper*



*The FIRST PLASTER COAT note the lip. Photo shows the re-rod hanging suspended from the lip. The dirt walls are moistened before cement is applied*



*PLACING THE RE-ROD Horizontals are in place and marks for vertical re-rod spacing are being made at equal intervals*



*CHECKING the walls for plumb before smoothing out the surface*



*The RE-ROD is closely spaced so the casting will withstand the force of moving and lowering it into place*



*COMPLETE CASTING which has been watered. The small holes allow water flow into the well*



*Digging up the casting*



*FIXING the casting into place by attaching to previous casting*

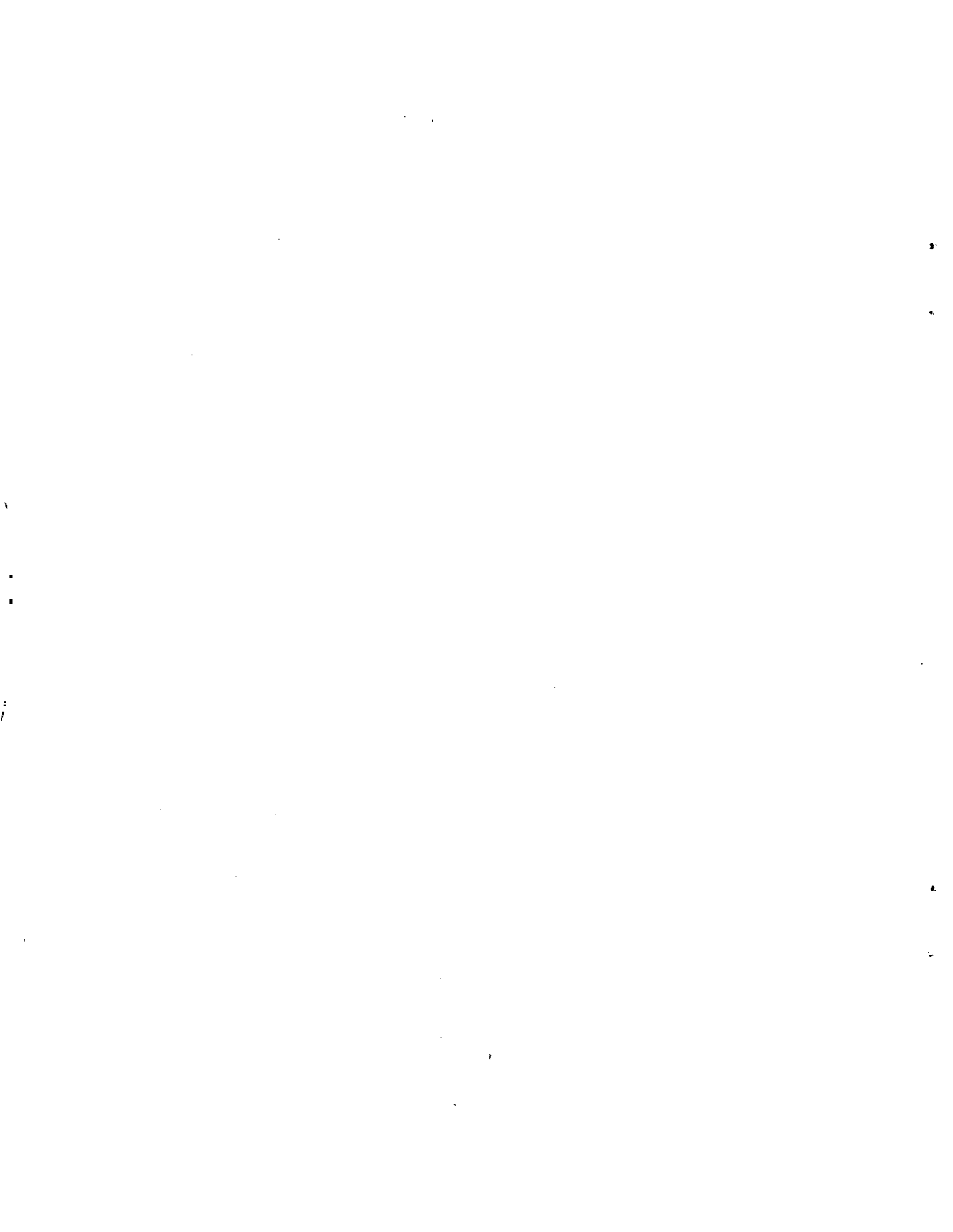

# 6. SENEGAL,

## HAND DUG PLASTERED WELL

### Robert W. McGurn, 1974

Peace Corps Senegal does not have a well-building program per se. Rather, well projects, widely varying in number of wells per project, are undertaken by Volunteers serving in "Animation Rurale", a generalized rural development program involved in construction, agriculture, animal husbandry, and hygiene. During the period between November 1973 and August 1974, Volunteers in "Animation Rurale" constructed about 200 new wells using the hand-dug plastering technique. The 1974 Togo Wells Conference has done much to alter our thinking as concerns both our program and the methods we use in well construction. The following presentation is a synthesis describing methods now being employed and alterations and improvements which we wish to employ in our projects in the future.

1. Clear away all loose topsoil and level the area of the proposed well site. Drive a straight piece of re-rod into the ground. Attach a piece of string, the length of the desired radius of the well, to the base of the re-rod. Tie another piece of re-rod to the other end and use this "compass" to draw a circle on the ground.
2. Bend a bar of 6 mm re-rod into a circle which conforms to the desired circumference of the well. The circle on the ground will act as your guide. Once the bar conforms to the circle on the ground, bend it around again, so that it is actually doubled, wrap the passes together with tie-wire, and cut off any excess. You can also verify the roundness of this ring by checking the uniformity of the curve. Use a bar conforming to the desired diameter and rotate it within the circle. This re-rod circle is the "drop-bar". The drop-bar will serve to keep the diameter of the well consistent and the walls straight.
3. Dig along the inside of the drop-bar with a trowel and lightly tap the drop-bar until it is slightly below ground level.
4. Dig one meter and be careful not to displace the drop-bar or excessively dig outward at the wall. After you have dug one



meter, you are ready to use the drop-bar. For right-handers, place your left hand lightly on the bar. Hold the trowel sideways under your left forearm. Using the upper back corner of the trowel, work towards your body and scrape away the dirt below the bar. Continue along the circumference, scraping away just enough dirt to allow the bar to drop. Continue until the bar is at the bottom of the hole. If you constantly eyeball the bar and keep it level, the bore of the well will be straight and consistent. Dig a bit with the trowel until the bar is below the floor of the first dig and cover it with sand. Do not smooth the wall.

5. Prepare a 4:1 water:cement mixture. Mix it well and splash it onto the well wall and the lip of the hole. This mixture helps seal the wall, prevents crumbling in loose sand, and gives the plaster an adhesive receiving surface.

6. Mix 3:1 sand:cement and begin plastering along the bottom of the wall. After the circuit is completed, begin working upward (always work in an upward direction, not side to side) forcing the cement into the gaps left by scraping. Plaster the well lip with a thick application (if a poured concrete lip is desired, leave this aside until after the first dig is dry, dig along outside the wall, and pour your concrete. The re-rod will already be in place if you follow the next step.)

7. Cut and bend re-rod for the verticles. Allow for the desired width of the well lip (usually 1-2 M), the depth of the dig (1M), and a hook at the lower end (5-10 cm). Place the verticles at 20 cm intervals along the wall. The bend should be made at 1 m at 90 degrees so that part of the bar rests on the lip and the rest hangs down the wall. The hooks will make the bar longer than the depth of the dig, so dig a bit and bury the hooks, but make sure that they are on the same side of the drop-bar as you are.

8. Cut and bend re-rod for the horizontals (circumference plus 30 cm). Place the horizontals at 20 cm, 40 cm, 60 cm, 80 cm in depth. Another will be placed later at 1 m. When placing the horizontals, bend 15 cm of the excess length outward and drive it into the wall to anchor the bar. The other 15 cm of excess is overlap to tie the bar to itself. At all times, place the

iron-work as flush as possible to the wall. Also place two or three concentric circles of re-rod of varying diameter on the elbows of the verticles on the lip. At each intersection of the verticles and horizontals, fasten the bars with tie wire and place a re-rod staple at every other intersection if necessary.

9. Apply the second coat of plaster but start 15 cm from the bottom of the dig.

10. Smooth and plumb the wall with a straight-edge. Fill in all gaps.

11. Dust the wall with pure dry cement and smooth it into the surface with the trowel. This helps harden, smooth, and protect the masonry.

12. Knock-off for the day.

13. Repeat step 4. The drop-bar and eyelets should be free if they were buried properly. Tap the bar lightly if it is stuck and lower it in the prescribed manner. Repeat steps 5-12 except for step 7. Instead of making the elbows as described, cut the bars at 1 m length plus enough excess (10-15 cm) to make a hook at each end. Attach the hooks to those of the verticles in the course above. Also place the horizontal at 1 m depth which was left out of the previous course and continue with the rest of the iron-work as described in step 7.

14. Continue in this manner until you find water.

15. Casings: If you've got casing molds, use them (see the Niger section). If you don't, use the method currently employed in Senegal as follows:

a) Repeat steps 1-3. Make sure the exterior diameter of the casing is adjusted to clear the interior diameter of the well wall by 5 cm on either side (since the well is usually about 7 cm thick, 14 cm for both wall thickness, 10 cm for clearance, therefore 24 cm. Make your casing drop-bar 30 cm smaller than the one you used on the well).

b) Dig 50 cm, lower the drop-bar, and remove the bar. Use the same drop-bar for all the casings in each well.

c) Apply the cement:water mixture.

d) Plaster

e) Cut verticles of 50 cm and place them at 15 cm intervals. Cut 3 horizontals (circumference plus 15 cm overlap) and place them at 10 cm, 25 cm, and 40 cm in depth. The 15 cm is overlap to tie the bar to itself. Do not bend the bar backward and drive it into the wall.

f) Apply the second coat of plaster. Make sure the walls are straight all the way to the top with no fall-away. Dust with cement.

g) Poke holes, about 20, along the wall with a piece of re-rod.

h) Place 8 re-rod staples, in pairs one above the other, at the intersections of the top and bottom horizontals with the verticles at 3,6,9, and 12 o'clock. These staples are used to attach the lowering ropes. After the casing has dried and has been dug up, bend the excess part of the staple outside the wall upward.

i) Make 4 casings.

j) Cure the casings for five days, dig them out, and lower them into the well. Try to line up all the staples on the casings, tie them with re-rod, bend them flush to the casing wall, and plaster over them. Also, plaster between casings.

16. Dig until the top of the uppermost casing is 30 cm above the lowest extent of the well wall.

17. Fill in the area behind the casings with gravel. Apply a thin coat of cement over the gravel.

18. Lay bricks for the guard wall.

19. Smile, you're finished.

Estimates:

---

| <u>Diameter</u> | <u>Bars 6 mm re-rod<br/>(1 bar of 12m)</u> | <u>Sacks of cement<br/>(50k per sack)</u> | <u>Course depth</u> |
|-----------------|--|---|---------------------|
| 150 cm          | 5.5  | 2   | 1m                  |
| 200 cm          | 7.5  | 3   | 1m                  |
| 120 cm (casing) | 2.4  | 1.5                                       | 50 cm               |
| 170 cm (casing) | 3.1  | 2.5                                       | 50 cm               |

---

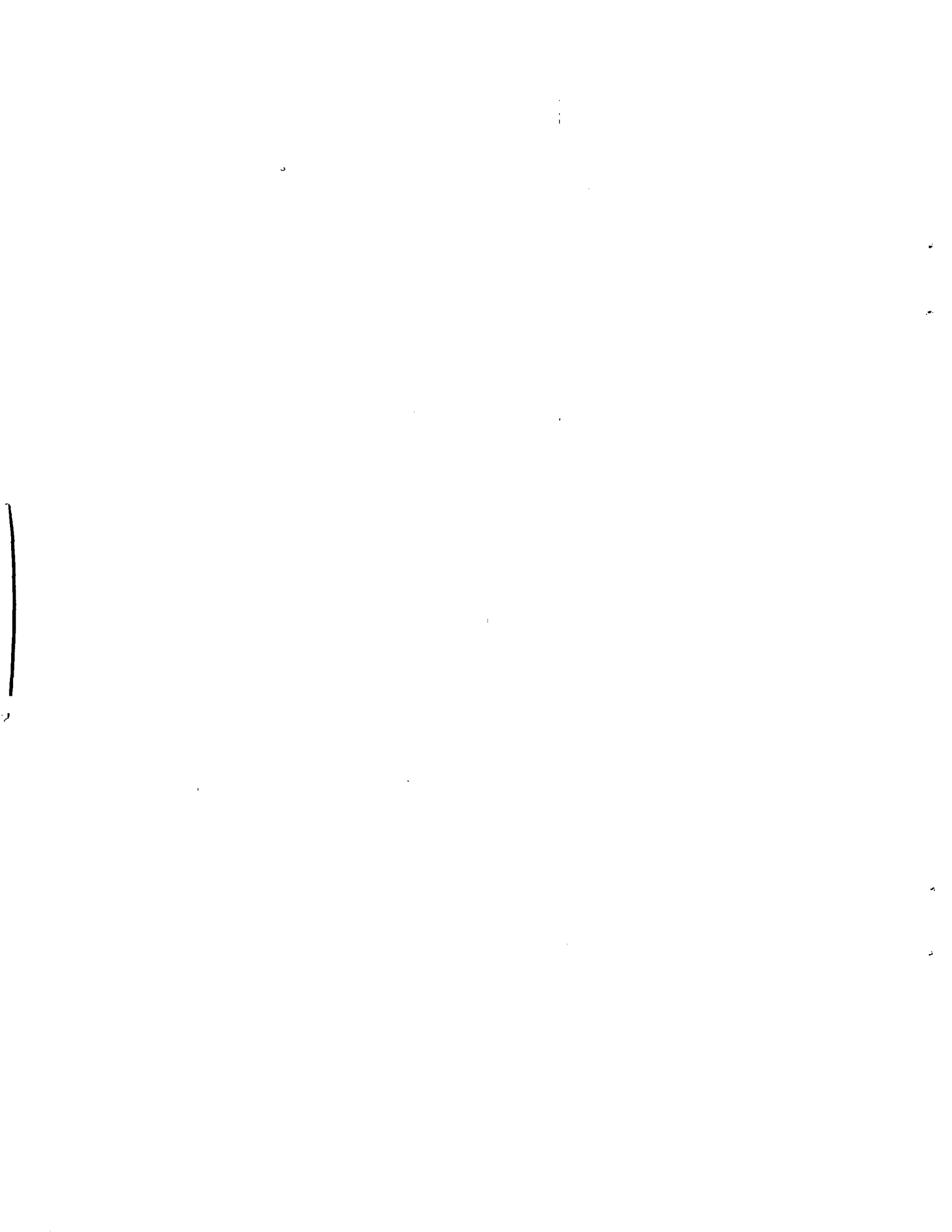

# **PART VI**

## **SMALL BORE WELLS**

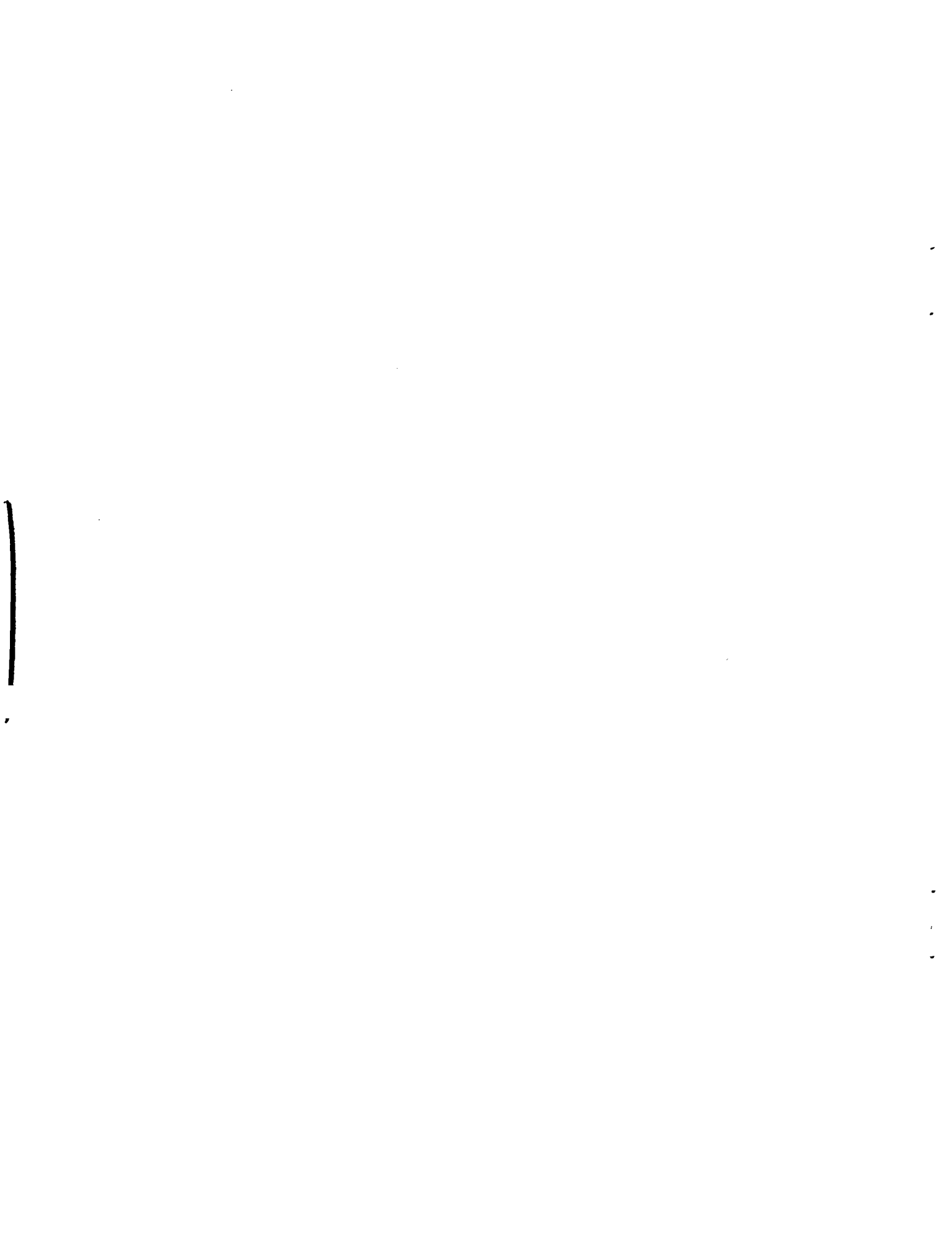

# 1. CHAD, SMALL BORE TUBEWELLS PCVs Dean Lanternier, Greg Greenwood, Michael Dower

## I. INTRODUCTION

## II. WELL DESIGN

## III. SOUTHERN WELL TEAM

- A. Machine Augering
- B. Pipe Installation and Development
- C. Team Organization and Personnel
- D. Problems in Starting

## IV. NORTHERN WELL TEAM

- A. FDAR/AID Drought Relief Project Proposal
- B. Development of the Project
- C. Technical Considerations

## APPENDIX

Drawing of Standard Well

Drawing of Slush Pump

Sample List of Tools

Bibliography

Suppliers



## I. INTRODUCTION

The Chad wells project was designed to provide potable water to the inhabitants of the Prefectures of the Lac, Kanem, Chari-Baguirmi and Moyen-Chari. This objective has not changed during the last seven years, though, because of the drought, water in itself has become a secondary objective. In some parts of the Moyen-Chari, villagers must walk up to fifteen kilometers to find water--contaminated water. To these ends we have two well teams, one stationed in Sarh, Moyen-Chari in Southern Chad and the other in N'Djamena, the Capital.

Another activity which has proven highly successful has been the training of Chadian counterparts in the methods and techniques of boring and installing small bore wells. At the present time, there are three well-trained Chadians working in Sarh, The Moyen-Chari, and four Chadian puisatiers in N'Djamena. Two of these well drillers work with us for the Fonds de Developpement et d'Action Rurale (FDAR), while the other two work for the Service d'Assainissement (Ministry of Health). This training has advanced to the point that we are looking for a Chadian to train in administration for the Sarh team, since the counterparts are capable of doing everything else without the direction of a Peace Corps Volunteer.

## II. WELL DESIGN

From the inception of the program, the Chad well teams have been installing closed 2-inch tubewells with a locally fabricated handpump mechanism (see drawing in appendix). The main body of the well is 2 inch galvanized pipe. At the end of the pipe is a Johnson stainless steel drive point screen which serves as the water inlet. The pump consists of a brass cylinder with removable foot valve (check valve) and piston. To date, we have used Eureka cylinders; that is, a cylinder that slides down inside the 2-inch pipe and is sealed against the pipe with a rubber packing ring. For the northern team, we are ordering the brass cylinders pressed inside a section of 2-inch pipe. This system will permit access to the screen at a later date, if one finds it to be necessary. The foot-valve and piston are both installed and operated by  $\frac{1}{2}$ " galvanized pump rod, which runs to the surface and threads into one end of the pump handle.

This basic well design was done by Mr. Tysen, an AID engineer in 1967, but we have seen fit to modify the design in order to increase the efficiency, longevity, and durability of our wells. The most important change was replacing the galvanized steel screen of Tysen's design with the stainless steel screen we presently use. This change was necessitated by the corrosive effects of the water, notably in the Lac Chad region, upon the galvanized screen. The life expectancy of galvanized screens in the Lae region was as short as six months, while in the Moyen-Chari the average was two to four years. Since the change, completed in 1971, not a single well has been replaced because of corroded screen, though encrustation still poses a small problem. Along these lines, we have installed a plastic screen in the Sarh region and intend to install another plastic screen in the north. Several years will be needed before an accurate assessment of the relative value of plastic as opposed to stainless steel screens can be made.

Tysen also suggested that we use 2-inch pistons and footvalves which use the steel pipe as the cylinder. While initially cheaper, we found that because of the roughness of the pipe walls, the piston leathers wore out very rapidly, causing frequent breakdowns. In most cases, we have removed the 2-inch pistons and footvalves and replaced them with Eureka cylinders.

The pump assembly has been strengthened by using a thicker base wood, from five to ten centimeters in thickness. The disc, used as a sanitary seal, has been similarly thickened to two millimeters. We are constantly trying to reduce the wear on the wooden pump handles and the metal bolts in the hand pump mechanism by soaking the handles in old crank case oil, spot welding straps together, and using lock washers on all bolts. Now the major cause of breakdowns is cup leather wear. We are ordering three leather pistons which will help alleviate this problem. Other changes will include the use of wood pump rod and more wash-down flushing well points on stainless steel screens.

The subsurface soil conditions in Chad affect the design and location of our wells in many ways. The two greatest limitations are the need of a water bearing sand layer (aquifer) of

a minimum thickness of one and a half meters, the screens being one and a quarter meters long, and the depth at which the aquifer lays.

It is imperative that the water pass freely through the opening of the screen from where it is pumped to the surface. Clay, clay-sand mixtures, and laterite formations, though they may be water bearing, do not have the necessary permeability to allow enough water to pass into the screen. For this reason, the screen must be entirely in a sand layer. If any part of the screen is blocked, the effectiveness will be greatly diminished, and wear problems accelerated. The blocking causes suction, created by the fact that the pumping capacity is greater than the ability of the aquifer to provide water for the well.

The depth at which the aquifer is located is the other limiting factor. We use the criteria that a six year old child should be able to lift the equivalent of a pail full of water (20 liters) from one of our wells. When the weight of a column of water, two inches in diameter, times the depth, and the weight of half inch pump rod are totaled, we found the static water level of thirty-five meters or less is essential. In the future, we should be able to install wells with a static water level of fifty meters or more by using wood pump rod.

### III. SOUTHERN WELL TEAM

#### A. Machine Augering

Machine boring is the exclusive technique in the Moyen-Chari, since the soil conditions and depth preclude all other simpler techniques. With the proper equipment, a drilling rig can penetrate formations such as broken rock and oxidized laterite, and for this reason we have found machine augering the best all around method for installing wells.

The technique used in Moyen-Chari is not difficult and can be described as follows:

After arriving in the village, the exact drilling site is chosen. Dispensaires, schools, the market, or a fairly central open area are all acceptable places. We make it a practice not to install the well in the chef's concession, at the Prefet's house, etc., since the well usually is not accessible to the villagers all the time in these places. Generally a point slightly higher than the surrounding area is the best, so that the excess water and spillage drains away from the well. The drill rig is parked, wheels blocked, and leveled out by means of two leveling jacks in the rear of the truck. It is important to set the rig as plumb as possible, since the augers and pipe tend to seek the most vertical line when being lowered into the hole, as will the pump rod when it is installed. Next the tower is raised and bolted into place. The drill head is attached by means of an auger holding pin to the auger, which in turn is attached to the drill chuck at the end of the spindle. It should be noted that the drill head should have carbide steel insert bits, as they wear slower than standard steel bits, and the extra cutting is needed in hard formations such as oxidized laterite. The spindle is hydraulically lowered until the bits are in the ground, at which time the clutch is engaged. Downward pressure is applied, and the auger descends. When the auger has completely descended, the spindle is raised to "clean" the hole as this assists bringing the cuttings to the surface. After the auger is lowered, the chuck is disconnected and raised. The second continuous-flight auger is placed upon the first, and the two are pinned together, as are the second auger and the chuck. This process is repeated until the aquifer is reached. Throughout the course of drilling, water is poured into the hole to assist in cooling the drill head and to help bring the cuttings to the surface by forming a "slurry" which rises easier than dry cuttings. When a five foot auger drops in less than 45 seconds with a corresponding change in engine speed as resistance is lessened, usually the aquifer has been reached. The drilling does not stop, however. One keeps going until resistance is again encountered. The purpose behind the continued drilling is to find out the depth of the aquifer, remembering the screen should be installed at the bottom of the aquifer. The augers

are left to rotate to clean the hole and to bring sand samples to the surface. The sand sample is needed as the grain size determines the slot (opening) size of the screen. The larger the grain, the higher number slot size can be used with a similar increase in the yield of the well.

By keeping a drilling log one knows at what depth the aquifer lays and the proper lengths of pipe can be prepared. The augers are then pulled out of the hole either one at a time as they were put in, or in strings of three to five at a time depending on the height of the tower.

Once the last auger has cleared the hole, the pipe and screen are lowered into the hole. The pipe should be installed as fast as possible, since the hole usually collapses from the pressure release when the augers are removed. Another possible blockage is caused when the sand from the aquifer rises in the hole, filling the space where the augers were. To a point, each minute represents meters, so the faster the pipe is lowered the better.

## B. Pipe Installation and Development

Two methods for pipe installation are in current use in Chad, driving and jetting. Driving, also called tapping, uses a weight suspended from a rope that runs through a pulley. On the drill rig, the rope is wrapped around a cathead to assist in lifting the weight. The weight is raised about one meter and left to fall on a special drive head coupling threaded on to the pipe. The force of the weight hitting the coupling drives the pipe into the ground, and as one section is driven in another is placed on top of it until the bottom of the aquifer is reached. At the same time the pipe is tapped, it is rotated clockwise with a chain or stilsen wrench because the driving tends to loosen the couplings.

The other method used is jetting. As with jetting a hole in the ground, water is required which is not always available. In wet clay-sand formations, jetting is easier than tapping since the circulation of the water lessens the resistance along the walls of the pipe. To jet, an opened screen is used. A sand-shark is attached to the screen. The sand-shark is a

well point with a place threaded for one inch pipe and a ball chock to close the hole off so sand does not plug the screen. The two inch pipe, with the one inch working pipe inside, is lowered into the hole so that it rests above the place the hole is blocked. The opposite end of the working pipe is attached to a king swivel or directly to the discharge hose from the pump. The pump is started, and when the water begins to circulate, the pipe is lowered to the blockage. The force of the water leaving the point clears the material and transports it to the surface as the pipe descends. If a king swivel is used, the pipe is turned; if not, the pipe is not turned as the turning will either twist the hose (if with the threads), or unscrew the working pipe (if again with threads). A settling pit catches the water to be recycled. It is necessary to have enough water so that the cuttings and sand can settle out, otherwise the material will be run through the pump, rapidly increasing wear and diminishing the pressure of the pump. When the first section is in place, the pump is stopped and another section of well pipe is added, as are the proper sections of working pipe. The process is repeated until the screen is in place.

After the screen is in place, the aquifer is developed. Developing has a two-fold purpose: first to rearrange the sand so that the largest grains are next to the screen, and secondly to pump out the "fines", fine sand that at a later date could plug the screen and possibly the piston and check valve. Ideally, 40-60% of the sand should be pumped out of the wells, though in Chad we have never achieved this figure because we do not stock a full range of screen sizes.

There are several tools which can be used in developing a well: the surge plunger (also known as a surge block), a slush pump, and a "flute", used in conjunction with a motorized pump. The southern well team generally starts development by backwashing. The "flute", a section of 1 inch pipe with several small holes in it and the end capped, is lowered at the end of a string of working pipe until it touches the bottom of the screen. The opposite end is coupled to the discharge hose, and the pump is started. The string is raised and lowered with a one meter stroke. The water being forced out of the

pipe and through the screen tumbles the grains of sand, helping to rearrange them around the screen. If the driving technique was used in the placement of the screen, the backwashing technique opens the slots that may have become plugged as the screen passed through a clay layer. Sometimes all the water pumped into the well is absorbed by the aquifer, which indicated that a very good aquifer is present. More commonly, some of the water is absorbed by the aquifer and some rises in the pipe and needs to be drained away from the well.

The second step is surging. The plunger is placed below the water level at the end of the working pipe. An up-down stroke is used, alternately drawing water through the screen and pushing the water out, again arranging the sand.

The last step is pumping the well. A regular piston and check valve are used to pump out the fines and clean the well. At this time measurements on the yield are taken.

An excellent tool, combining the function of a surge block and pistoning, is the slush pump. Basically, it is two sections of pipe, the outer with a check valve, that is slightly longer than the inner section with the piston (see drawing in appendix). The check valve is seated at the bottom of the well, and the unit is pumped with a fairly short strike until the water reaches the surface. The puisatier then lifts the whole unit up from the bottom, breaking the seal. The weight of the falling water backwashes the screen. The process is repeated several times. Then one can alternately pump out the fines and surge the well. This tool results in superior development of the well and saves time since it is not necessary to pull the string of working pipe to change tools.

The last steps are putting the finishing touches on the well. First the cylinder is placed in the well at least a meter below the static water level. This is necessary since the piston is a single action piston designed to lift not suck the water to the surface. Next, the pump rod with piston and check attached are placed in the well. The check is seated and the piston is unscrewed from it. The pump rod is raised, marked, and cut so the piston is about three centimeters above the

check when the handle is in the down position. This avoids any thread damage to the check valve. Then the base is put in place along with the base support pipe. The dalle (base) is cemented with a drainage canal to carry the excess water away from the well. Sometimes a drainage pit must be dug if the ability of the ground is limited to the amount of water that can be absorbed. At a later date when the cement has dried, the handle is placed on the well.

### C. Team Organization and Personnel

In late 1972 all the well teams for which the Volunteers worked were consolidated under the Fonds de Developpement et d' Action Rurale. Previously the two teams based in N'Djamena worked for the Service d'Assainissement. Because the Southern team had long been operated by FDAR, it has continued to run reasonably well. On the other hand, the Northern (N'Djamena) well team has suffered the confusion of getting itself organized under FDAR for almost a year and a half. As such, the organization and operation of the Northern well team will be discussed separate from that of the Sarh team.

The Sarh team consists of two PCVs and three Chadian puisatiers. The team has a checking account in Sarh with the PCVs as signataires. This account is renewed each trimester and is to be used for operating expenses. Gasoline is purchased with FDAR "bons pour". Wells materials and large purchases are handled by orders and "bons de commande" issued by FDAR in N'Djamena. Lately, FDAR's funds had been depleted to the point that it could not place a large wells material order, but recently FDAR did place a small order.

The Sarh team works out of an FDAR warehouse in Sarh. The Chadian government has supplied the team with a 1964 Acker drilling rig, mounted on a 1964 Dodge Power Wagon. OXFAM supplied a Landrover pickup truck, while Peace Corps bought a Saviem "poids lourd" for the team's use.

The Sarh team enjoys relative freedom regarding the daily operations, choosing of new well sites etc, because all the management, both Peace Corps and FDAR, are in N'Djamena and



communications take time to arrive. With this freedom comes the responsibility to maximize our resources, gasoline, money, etc. This also includes submitting monthly reports, financial reports, and so on. Because the Volunteers have shown the responsibility, our relations are very good with the government. The government also accepts usually without question site proposals since they understand that these villages were chosen with good reasons.

It is essential for the Volunteer to have a variety of skills. The main role of the Volunteer is that of an administrator and/or Conseiller Technique, so he should know something about practically everything. Pump mechanisms, drilling techniques and vehicle maintenance are the most important though accounting, administration and local law and customs should be understood, however vaguely. The Volunteer should put in as much hard, physical labor as the Chadian counterparts, getting away from the idea of the "grand patron", a carry-over from the colonial days. Occasionally as "chef d'equipe", the idea that you are patron must be used if only to solve some problem that otherwise hampers the effectiveness of the team. The Volunteer must try to perform effectively, since that is the main input of the Peace Corps into the program.

The Chad well teams are fortunate to have good counterparts, a couple of whom are outstanding. The relationship between the Volunteer and the Chadians is very relaxed. One finds that the counterparts know far more about drilling wells than the Volunteer could hope to pick-up in two years of service. Their imagination and knowledge can be a constant source of assistance to the Volunteer. In Sarh, they are trained well enough that we are searching for a Chadian to train in the administration of the team.

Life in the bush is a refreshing, almost necessary, change from the cities where we are based. This is where the well team becomes truly effective. Our trips "en brousse" can last anywhere from two days to two months, depending on the work and the arrival of necessary supplies. On these tournées, we take everything we need for living and working. After arriving at the site, camp is set up. We usually are given a house, though seldom used except during the rainy season, preferring to sleep under the stars. After camp is set up, we begin to drill the

well. The normal work day varies, though 6:00 - 12:00 and from 16:00 - 18:00 in the afternoon is not unusual, six and a half or seven days a week, depending on the planned length of stay "en brousse". The work in one village may take from two to seven days, depending on the soil conditions, problems encountered, etc. It is not uncommon to receive gifts of eggs, chickens, or (on rare occasions) a goat. Many times some boule and sauce is prepared for us after the morning's work. Tea is another frequently seen gift. When the well is finished, we pack up and head to the next site, to repeat the process again.

#### D. Problems in Starting

There are several drawbacks to a small bore wells program. The initial investment is high. Trucks, drill rigs, and tools are needed. Organizations such as OXFAM donate money for these types of projects, as does the United Nations. With the present drought, drought relief money should be available from any number of sources. There is the possibility that the drill rigs are already in the country, as was the case in Chad. It then becomes necessary to obtain the release of the equipment for a small bore program. Ordering materials poses a problem, as normally six months should be allowed between the placement of the order and delivery of the same. The same applies to spare parts. A minor breakdown can stop work for months if parts cannot be found locally. Thus, you must be far ahead of the current situation so the least possible time is lost when parts run out and when the new order arrives. The level of technical sophistication requires constant attention to the equipment and mechanical skills on the part of the Volunteer. The last drawback is that there is always water but not always an aquifer within reach because of the limitations of the drill rig or the impossibility of installing a hand pump unit. However, in the end, the advantages far outweigh the disadvantages.

#### IV. NORTHERN WELL TEAM

##### A.

Rather than discuss immediately the past problems of the Northern well team, let us first show you the official outline of

the project on which we are presently working.

**Description of the Activity:** The purpose of this project is to provide potable water to population centers in the Lac and Kanem areas affected by the drought. The reason for carrying out this \$200,000 project is that in the shortest time possible it will provide settled groups of people with sources of water potable, easy to keep, in good condition. By improving and changing the current program resources of the Ministry of Public Works and Territorial Management of the Republic of Chad, this project will secure for the inhabitants of relatively populous and drought stricken areas a well maintenance program which, over a long period, will insure them of a water supply that will be virtually free of viruses and will not be dependent on seasonal changes.

Since the well-drilling teams of the Fonds de Developpement et d'Action Rurale (FDAR) do not presently possess sufficient resources for carrying out a project of this scope in a short time span, it will be necessary to provide all the equipment which the two well teams will need for drilling and installing the wells. Depending on the cost, one or preferably two drilling rigs will be procured for the installation phase of the project for wells having a depth more than 15 meters.

Furthermore, one or two Land-Rovers will be needed during the project period covering the installation of wells less than 15 meters deep. They will be used as project support vehicles for the drilling equipment. The final number of Land Rovers will depend on the price and on the quantity of drilling rigs purchased. In any case, the total number of vehicles purchased with AID funds will not be more than three.

To meet the equipment needs of the well drilling teams, AID will finance the purchase of tools, the installation of the equipment, camping facilities, well materials and supplies for a storehouse for preparing pump bases and maintaining vehicles.

The maintenance team and two installation teams will each consist of two FDAR drilling technicians and two well-trained American

Peace Corps Volunteers. The salaries of the Peace Corps Volunteers will be paid by their organization. An item in the budget for this project will cover salaries for the FDAR team members for a period of thirty months. The vehicle for the maintenance team will be the Land Rover currently being used by the FDAR well-drilling team in N'Djamena.

Implementation schedule: The carrying out of this implementation schedule will depend upon the availability of the drilling equipment. As soon as funds are deposited in the Special Account of the Banque de Developpement du Tchad project personnel will place orders for materials for the wells, and when these materials arrive the two installation teams will begin work in the regions of Lake Tchad where the water level is at a depth of less than 15 meters, so that "hand-drilling" is possible. It is likely that the vehicles ordered for the project will get to Chad nine or twelve months after funding procedures start. Thus, the two FDAR drilling teams will start by using the diesel Land Rover belonging to FDAR (and to be assigned ultimately to the maintenance team) and a similar vehicle lent by Peace Corps. After the end of this phase of manually installing from 60 to 80 wells in an area spreading out to approximately 80 kilometers from Lake Chad, operations with the drilling equipment will begin in the southern region of Kanem and will gradually move northward.

Each four-man team will work approximately six weeks and return to N'Djamena for three or four weeks for resupply and rest.

In spite of the delays likely to result from the assembling and preparation of materials, uncertain drilling conditions, vehicular breakdowns in the lack of spare parts, it seems reasonable to expect that each well installation team will be able to install on the average one well a week during the two years of the project. Experience indicates that if orders for materials and tools are placed by May 15, 1974, we can expect delivery by air freight within 90 days. Counting a preparatory period of 30 days and anticipating receipt in due time of pipes, wood, etc., and of fuel from local suppliers, the installation of wells having a depth of less than 15 meters will begin about November 1, 1974, and will end about July 31, 1975. The subsequent series of wells will be constructed with a drilling rig

and Land Rover support vehicles. Operating in Kanem and in the Eastern regions of Lac prefecture, the teams will do the deep drilling until about November 30, 1976. Beginning their share of the work about February 1, 1975, the maintenance team will continue its periodic visits to well sites two or three times a year.

In summary, the proposed implementation schedule is as follows:

- |     |  |                               |
|-----|--|-------------------------------|
| (a) | Place orders for tools and materials for installing wells. (80)    | May 15, 1974                  |
| (b) | Local preparation of installation tools                            | June 1, 1974<br>Aug. 15, '74  |
| (c) | Place orders for drilling rig and vehicles                         | June 15, 1974                 |
| (d) | Arrival by air freight of tools and materials for installing wells | Sept. 1, 1974                 |
| (e) | Preparation of wooden pumpstands and well installation tools       | Sept. 1, 1974<br>Nov. 1, 1974 |
| (f) | Phase I. Begin installations. (water level less than 15 meters)    | Nov. 1, 1974                  |
| (g) | Order materials and parts for Phase II wells (100)                 | Oct. 1, 1974                  |
| (h) | Arrival by surface of tools and materials for wells (40)           | Dec. 15, 1974                 |
| (i) | Maintenance teams start their rounds                               | Feb. 1, 1975                  |
| (j) | Arrival of drilling rig and vehicles                               | May 1, 1975                   |
| (k) | Arrival of materials and parts for Phase II                        | May 15, 1975                  |
| (l) | End of Phase I (60-80 wells installed)                             | July 1, 1975                  |
| (m) | Training period, use of drilling rig                               | Aug. 1-30, '75                |

- (n) Beginning of installation of wells, Phase II. (Water level more than 15m). Sept. 1, 1975
- (o) End of project Nov. 30, 1975
- (p) Operations of the FDAR maintenance team Every 4 months
- (q) Resuming of regular operations of FDAR in Chari-Baguirmi and Mayo-Kebbi Dec. 1, 1976

Objectives/Targets: This project is aimed towards the installation of 180 small wells which will provide direct benefits to 55,000 people. A list of well sites, to be sent to AID when established, will be drawn up by FDAR in terms of the following priorities:

- (a) Each main village of the prefectures of Lac and Kanem having more than 200 inhabitants will get a well.
- (b) An additional well will be installed on the basis of one well for 400 persons.
- (c) Each well will be located so that regular and periodic maintenance can be efficiently performed.
- (d) Several wells will be drilled in regions where efforts are being made to cause nomadic populations to settle.

Most of these wells, in 140 villages, will be located in the prefecture of Lac and in the southwestern part of Kanem prefecture. Thus, it is no problem to schedule three visits a year for each well for inspection and maintenance.

Budget: AID funds for this project will be used as follows:

- (a) Three vehicles and a drilling rig including parts and shipment by surface (with a second drilling rig to be purchased if funds in this budget item are sufficient). 70,000
- (b) Fuel, oil, vehicular maintenance 15,000
- (c) Tools, materials for wells 86,000

|  |           |
|--|-----------|
| (d) Shipment of materials to well sites                              | 10,000    |
| (e) Maintenance materials for the wells                              | 10,000    |
| (f) Camping facilities   | 1,000     |
| (g) Operating expenses and salaries for four<br>Chadian counterparts | 8,000     |
|  | <hr/>     |
| TOTAL  | \$200,000 |

Non-AID inputs: FDAR will contribute to this project in the following manner:

- (a) Making available the present resources of the well drilling teams of the north
- (b) Providing a storehouse for the preparation of materials and their safekeeping
- (c) Making available tools and installation equipment
- (d) Making available one diesel Land Rover
- (e) Approving the designation of six well technicians from FDAR, who then will be paid from FDAR's regular budget, and six Peace Corps Volunteers.

#### B. Development of Project

From the last paragraph of the FDAR proposal "Contributions of FDAR", one might assume that the AID role is one of plugging money into an already running program. Nothing could be further from the truth. The short history of the USAID Sahelian Drought Relief and Recovery Effort in Chad has been one of creating some rather large somethings (costing \$1.5 million) out of next to nothing. The AID/FDAR project gives fine examples of the questions one meets when starting a small-bore wells program.

Toward the end of October, 1973, the first AID Drought Relief fact-finding mission arrived in Chad. Congress was at that time considering a bill allocating \$1.5 million, to be spent within

90 days, on projects directly ameliorating the effects of the drought in Chad. The mission was doing groundwork, contacting numerous agencies in Chad to find out if perhaps they would like a little free money and, if so, would they please draw up a drought-relief project proposal and send it to AID. This request met with unchecked glee at Peace Corps because the request presented the northern well team an ideal opportunity "to do things right".

Since the northern well team had been transferred from Sante Publique to FDAR a year before, it had suffered almost complete disorganization. The one old drilling rig (circa 1954) we possessed had broken down and was deemed beyond repair. We had no warehouse and no bank account. A wells materials order had been lost at the FDAR office for almost a year. The program drawn up by the Direction du FDAR and the Prefecture of Mayo-Kebbi called for the installation of wells at widely scattered locations, which, even if we had had the wells materials, would have led to a higher installation cost and required a more inconvenient and costly tournee to provide periodic maintenance. In Chad, that generally means an expensive well and one which gets infrequent, if any, maintenance is often en panne, thus diminishing even further the credibility of the FDAR/Peace Corps well teams. As a result of these organizational problems, the Equipe de Forage du Nord was perilously close to non-existence.

The AID money would allow us, then, to purchase materials and equipment in sufficient quantity and of sufficient quality that for once we had a chance of doing a relatively efficient job for almost several years. Beyond that, a definition of the drought-affected zone accompanied the AID money and allowed us to focus our efforts in one region of Chad, resulting, we hoped, in lower installation costs and cheaper more certain maintenance. If with the AID money FDAR/PC northern well team could equip and organize itself to provide cheap and reliable potable water, then after the AID funds were exhausted, the well team would be in a better position to compete for Chadian government money and support which would be essential if the well team is ever to be handed over totally to Chad.

The AID mission, while anxious to obligate its money, had to ask some challenging questions, the paramount being just how the



installation of small-bore wells providing potable water for human consumption was drought relief. The drought in Chad manifested itself most severely in lack of forage for cattle and crop failures for people. An actual lack of drinking water was seldom, if ever, the most important problem. Our goal was to improve the quality of drinking water by providing potable water in place of oft-polluted traditional open well water. Potable water would reduce the threat posed by common, water-borne diseases to people weakened by malnutrition. Potable water would also be one of the most effective measures against water-borne epidemic diseases, such as cholera, which typically afflict drought and famine areas. The AID mission accepted this as a legitimate drought-related goal and encouraged us to draw up a project.

Given the basic goal of delivering potable water with a well design already used elsewhere in Chad, we had three rather general questions to answer: where were we going to install the wells, how large an organization were we going to create, and how many wells were there to be.

The AID mission had already defined the drought zone, but that amounted to most of central and northern Chad - considerably more than we felt we could handle. We confined our project zone to the Lake and Kanem Prefectures, directly north of Lake Chad, reaching from 13 to 15 degrees N and from 14 to 17 degrees E. It is a region densely populated for the Sahel and has suffered several years without harvests or good grass. The area, traditionally called the Kanem, is also probably the easiest place to dig in all of Chad. The region is covered by an erg, a sand sea up to 60 m thick, with the water table generally close to the surface (5-25 m). The sand grain sizes vary from place to place but provide an aquifer that yields more than enough for our wells. Finally, the region is relatively close to N'Djamena, the capital, allowing easier maintenance installation.

The ideal of the well team in Chad has been one with two Volunteers, one a first year volunteer, the other a second-year volunteer, with two Chadian counterparts. This ideal would provide continuity for the program with a sort of on-going on-the-job training. Thus, a massive influx of new Volunteers for the AID project would present serious training difficulties. When the AID project was originally planned, we foresaw only two continuing Volunteers with one RPCV as training director.

We requested for new Volunteers a number we could effectively train with our present manpower. With the addition of four new Chadian counterparts, we would have 6 PCV's and 6 Chadian counterparts, enough people for three well teams. Since that time, we have added another Chadian counterpart to be trained as administrator for the project. With three teams we could guarantee that at least two teams would always be en brousse. We estimated that a team could average one well per week, giving a total productivity of 100 wells per year. This seemed appropriate to the scale of the project which, as you have read, was to be 180 wells.

Concurrently with the consideration of personnel requirements, we made a rank-size study of the villages in the Kanem, as listed in the 1968 census of the area. The study gave the numbers of villages in about 8 different size categories (e.g. 350 villages with between 100 and 125 people, 200 with between 125 and 150, etc.) We used this study to compare the total number of wells required by different installation strategies. The strategies resulted from decisions made on two questions: (1) What level the population had to reach before it justified installing even one well, and (2) What increment of population increase justified additional wells. We could compare what would happen if we installed wells in every village with at least 100 people and added additional wells at the rate of one for every 200 people, with a strategy based on a threshold of 200 and a rate of one additional well for every 400 people. From previous experience we found 400 people per well to be a workable load on a well, requiring maintenance every 4-6 months. Fewer than 400 people per well gave fewer maintenance problems and was certainly desirable. A higher ration required much more frequent maintenance tournees. The rank-size study gave us a threshold of 200 people and a rate of one additional well for every 400 people (i.e. villages 200-400, 1 well; villages 400-800, 2 wells; etc) as a strategy that gave an acceptable geographic spread of benefits, an acceptable level of maintenance difficulties, and a total number of 180 wells, a number that jived well with what our organization could provide. The requirements of the region fit conveniently with what we felt we could accomplish.

Thus, having established the basic parameters of the project (2 years, 180 wells, 12 people), we next needed to figure out

generally what we needed to do the job and approximately how much it would cost.

Drilling techniques were dictated by ground conditions. In regions where water was within 15 m of the surface, previous experience had shown hand augering to be a fast and effective method of drilling. In areas with water deeper than 15 m, machine augering seemed to be the best bet.

While installation was the first goal, maintenance was the key to success in the project. We committed one of our three well teams to maintenance. Equipped with their own Landrover, the maintenance team would start checking and repairing wells four months after the start of installation and would return every four months to do the maintenance on wells installed up to that point. As installation progressed, the maintenance tournee would of necessity grow longer and longer, until when the installation was finished, the tournee would consist of visiting all 180 wells, traveling 3000 km, and spending between one and two months on the road.

We were certain that maintenance would be done as long as AID funded the project, but we did have some doubts as to what would happen in two or three years when AID ended its involvement. If FDAR did not continue the regular maintenance, within a year or two all 180 wells would be 'en panne'. Without a commitment from FDAR to maintain the wells, the entire project was of dubious value. Thus we wrote in our proposal to the Direction of FDAR that FDAR should commit:

- 1) Four new counterparts and their salaries (nothing more than they had done before)
- 2) Free warehouse space (something FDAR should have provided at least a year before but never had)
- 3) A vehicle for the maintenance team
- 4) Fuel and repairs necessary to insure a maintenance tournee every 4 months (this would not start until after all the wells were installed, i.e. 2-3 years hence)
- 5) Well repair parts (FDAR would only start paying this after

the five-year supply of parts left by AID was exhausted, i.e. 7-8 years hence). We felt these requests were not excessive but were the minimum that would insure a long life for our wells after AID left.

The estimated budget entries shown in the proposal were made without a great deal of precise information. We estimated pipe without having made a site survey or even knowing precisely where the sites were. We estimated the cost of drilling rigs without having investigated what was available. Such approximations were necessary if we were to deliver the proposal on time, and besides, approximations were all AID wanted at that point. Our proposal for \$200,000 for 180 wells, which when one considers the quantity of equipment to be turned over to FDAR upon completion, brings the cost per well to about \$700. FDAR revised our proposal a little, then sent it to the American Embassy, which lumped it together with other project proposals and sent the package to AID/Washington D.C.

While awaiting Congressional approval of the money, we started on our second cycle of information gathering. We made a tournee through the Lake and Kanem Prefectures to discuss the project with the local administrators and collect their lists of preferred well sites. Our study of the population figures had provided only a guide as to how many wells the area needed. Many villages listed in the census could not be found on the maps, and population movements, because of the drought, made village population figures useless. Only the local administrators were close enough to the situation to provide an appropriate list of well sites. Also, they were the government in the region. Our cooperation with their wishes would insure a smooth installation schedule.

In each prefecture we collected lists of well sites from each sousprefet and chef de poste administratif. We took these lists to the prefet and after giving him the total number of wells allotted to his prefecture by FDAR, we discussed our recommendations which usually concerned juggling the number of wells per village to maintain the ratio of 400 people per well and eliminating sites that were isolated and would hinder maintenance tournees. By and large, discussions with the prefets gave us well sites that were located along main routes, allowing the

easiest and most efficient installation and maintenance.

We also visited a great number of the proposed sites and surveyed them to determine depth to water table. From our survey and from information already compiled by Bureau de l'eau, we could determine fairly easily the amount of pipe needed at each site.

The second part of the information gathering consisted of drawing up lists of everything we would need in terms of tools and wells materials, right down to the minutiae and then requesting proforma invoices for these items from suppliers in the United States and France. This was a most demanding and often tedious task, requiring considerable anticipation of problems; but it was probably the most critical step in planning. If bottlenecks in the program were ever to occur, they would most likely result from hasty or superficial work at this level.

We were less certain as to what we wanted for trucks and drilling rigs, so for these items we contacted numerous different manufacturers for information and prices.

While awaiting the return of the proforma invoices and the arrival of the AID money, all the lists of tools, well materials and pump parts were translated into French to facilitate ordering, since it was FDAR who was to do the ordering.

The first allotment of money came at the end of April and was deposited in a bank. The money is for a number of projects, and while we had reserved more than enough money for our project, procedures for getting at it involved many hands and a considerable wait. Thus, ordering materials is itself a rather formidable hurdle. Beyond that, we anticipate problems in clearing our material through customs and ensuring that we have at least some warehouse space for storing newly-arrived materials. If we are lucky, we will be en brosse installing the first wells in September, 1974.

### C. Technical Considerations

One of the major benefits of working in the Kanem region is an

easily penetrable overburden. The entire region is an erg, a great sand sea, more or less stabilized by trees and grass. In places wind-formed dunes attain heights of 60 m. The interdunes, called wadis, are pockets of lake clay resting on the dune sand. These wadis allow and control population distribution in Kanem because they are the only places where traditional open wells can be dug. Luckily, wadis are numerous, and water can be found beneath them at shallow depths (from 1 to 10 meters). Thus, if one wishes to install tubewells in villages which are already on dunes, one must penetrate from 10 to 70 meters of dry sand before reaching the water table. In almost all of the Kanem, the water table rests in the dune sands, giving an adequate aquifer.

#### Hand Augering

In the region bordering Lake Chad, one finds low dunes, a shallow water table, and very fine sand aquifer. In the conditions hand augering is a light and fast method of digging a hole. A crew of four men can auger a 4-inch hole to 15 meters in a morning. Fifteen meters is the effective limit of hand augering in sand. Beyond that depth the hole usually collapses because the auger often hits the walls as it is being removed. One must also stop when one reaches the water table as wet sand will not support a hole.

To install the well, one attaches a stainless steel drive point screen, usually a n<sup>o</sup>6 or n<sup>o</sup>8 slot size, to the end of the well pipe, places the assembled well in the hole, and drives the screen down into the wet sand. A drive point will descend quickly through wet sand, slows to a crawl in silt, and stops when it touches clay. Thus, one drives the screen until it slows almost to a stop. This will place the screen at the bottom of the more permeable sand. The screen ought to be at least three to four meters into the water table.

After driving the screen, we usually pump the well with the slush pump. By the ease of pumping and the color of the water one can see if indeed the screen is in the fine sand or if it has been driven into a silt layer or an old natron bog. If the screen is well-placed, one can begin development.

The northern well team uses a slightly different regime of development than that in the South. Our research has shown that for high velocity jet development to be effective, one must use a piston pump. Piston pumps are heavy items, and with our vehicles (Landrovers) transporting piston pumps over the sand is virtually out of the question. Thus, we develop using only a surge block and a slush pump.

We use the surge block just as the southern team does, but we use the slushpump to pump out the fine grains of sand that have been sucked in and deposited in the bottom of the screen. After it appears that most of the sand has been pumped out, we use the pump as described above - to back wash the screen. Because the sand around the Lake is very fine, the 1-2-3 process used in the South does not sufficiently develop the aquifer. We use a regime of 60 minutes plunging - 15 minutes pumping - 60 minutes plunging and so on until no more sand can be sucked into the screen and suction has been eliminated. Development is terrifically important: a poorly developed well pumps harder, delivers less water, and destroys leathers much faster than a well-developed well. A couple of extra hours of developing is a wise investment.

These last three tools - the drive weight, the piston plunger, and the slush pump are all driven by a capstan attached to the rear wheel of our LandRover. The capstan works well, but we believe that using it may strain the drive train of the truck in ways not anticipated in the truck design. On our new LandRovers, therefore, we intend to order bumper mounted capstans which run off the PTO.

In the AID project, we are going to use as a pump cylinder a brass sleeve pre-pressed into a section of 2-inch pipe. Thus, the cylinder is installed as part of the well pipe. This arrangement allows easier access to the screen in the event that one wants to redevelop the well or clean the screen with acids. The cylinder should rest several meters below static water level. The footvalve and piston are installed in the cylinder with metal pump rod running to the surface to connect to the pump handle. The pump base and handle are screwed onto the well pipe, a concrete base is poured, and the well is completed. If all goes well, the whole installation takes about four days. Basic

equipment consists of a LandRover, tripod, pulley, rope, auger, and 3/4 inch working pipe, drive weight and guide, piston plunger, slush pump, capstan, tools, and wells materials.

### Machine Augering in the Sand

Away from the Lake, water table is commonly 20 meters below the surface, up to 55 m down in regions with high dunes. The sand is consistently larger-grained. In this area we will probably use machine-augering. A small augering rig will most certainly dig through the sand; the only doubt is whether the hole will collapse as one removes the augers. We have asked numerous experts and none were able to give a definite answer though we were encouraged to try augering. In any case, most drilling rigs are adaptable to several systems of drilling, so we could use the same rig but with different accessories. With machine augering one can auger below the water table to see if any clay or silt layers are present. The hole below the water table will collapse when the augers are removed, but one has the assurance that one will meet no problems in drilling the screen into the aquifer sand. After augering the hole, one assembles the well as before and drives it down into the aquifer.

We intend to test and develop the screen with the same type of slush pump and piston plunger as before, all running off the drilling rig cat head. If one were to mount the rig on a large truck, one could also carry a medium capacity piston pump which would allow screen development with high-pressure jetting.

The pump cylinders, parts, and handles for these deeper wells will be the same as those of the shallower wells. However, we intend to replace the metal pump rod with wooden rod which should make the wells easier to pump. The wooden pump rod is bigger than the metal rod, thereby reducing the volume and weight of the column of water that one lifts with the piston.

### Alternative Procedures

One installation method suggested to us by virtually everyone is flushing. Flushing differs from jetting in that one uses a low-pressure centrifugal pump instead of a high-pressure piston pump. The high-pressure jet (50-70 psi vs. 30-40 psi of the



centrifugal pump) is, according to our sources, not really necessary in the sand. One can also buy special flush-down points sand sharks for screens so that one can flush down the complete screen and well pipe assembly at once. It sounds like an excellent method but one problem we anticipate is finding enough water with which to flush. One consultant gave us a drilling rate of 25 feet in 5 minutes, about 1.5m per minute. Given even low pumping rate of around 250 liters a minute, flushing from 12m (the bottom of the hand augered hole) to a 20 m water table would require 1250 L of water. This quantity would be considerably less if one could count on a return of water out the hole, but no one knows how much water loss to the dry sand we should expect.

A traditional open well can be found in almost every wadi and possibly one could use the centrifugal pump to draw out water, but none of the open wells penetrate the sand to any depth, giving the wells a very low output. One would probably pump out the well in a few minutes. Another source of water might be the tubewell one just installed in the last village, but dragging water in a tank trailer over the sand for any distance at all sounds like more trouble than it is worth.

A fourth pertinent, but as yet untried method, particularly suited to working in sand, uses casing and a sand bailer. One hand-augers as far as possible, then sets an open pipe in the hole. By alternately driving down the pipe and bailing out the sand forced inside the pipe, one can gradually deepen the cased hole as far as one has casing, even down in the aquifer. Then it is simply a matter of placing the assembled well inside the casing and knocking out the casing. Using casing also allows the option of gravel-packing the well which according to reports should result in a better developed well.

#### Adaptability

While these are the techniques we are considering for use in the sand, how workable are they in other ground conditions?

The value of machine augering in areas of thick, hard overburden has already been demonstrated by FDAR's well team in Sarh. Indeed, these conditions are best for machine-augering: softer formations introduce the problem of caving.

Hand augering is an efficient and easily transportable method but it has several limitations. It can only be used in soft formations: sand, silt, and clay. As mentioned above, the maximum depth attainable in sand is 15 m. In clay one can auger to greater depths because a hole in clay almost never collapses above or below the water table. Thus, as long as one is in clay, the depth to which one can go is limited by one's ability to lift the auger and to endure the tedium of disconnecting and reconnecting sections of pipe as one removes and replaces the auger. Probably 70-80% of the time spent hand augering is actually passed in removing and replacing the auger in the hole. The current record for hand augering in clay is somewhere in excess of 22 m. However, as soon as one hits a sand layer below the water table, one has the problem of the collapsing hole. This is a particularly serious limitation in laminated alluvial formations. While in the sand one can be pretty certain that one will hit no clay layers beneath the water table, the very nature of alluvial deposits makes it probably that a clay layer is lurking somewhere beneath the first sand layer. Whether it is 1m or 7 m below is impossible to know with hand augering. The solution might be to use casing, with two different augers, a large one to form the hole into which the casing is lowered, and a smaller one to clean out the inside of the casing as it is driven in the sand.

### Sludger

Earlier this year we were looking around for some short-term work to do before the AID project was to start. We requested two windmills from a sister water agency and started looking for a suitable technique for digging a hole large enough to accommodate the windmills' 3 inch pipe. Our hand augers were not large enough and our old drilling rig which in principle digs a 4½ inch hole was en panne. Looking through the AID small bore wells manual, we found the so-called sledger method.

It required water but our well site was close to a private water tower so that getting water was not a great problem. So we fabricated the necessary parts out of pipe, couplings, and sheet metal, culminating in a many-bladed chopping bit with water ports, a check valve made with a 2-inch rubber coated steel ball inside a short piece of 3-inch pipe, and a long string of 2-inch pipe. We filled the hole with water; the chopping bit, check valve, and string of pipe were lowered into the hole and given a spudding motion by using the rear wheel capstan just as we use it to drive pipe. The spudding motion made the check valve function as an inertia pump, pumping up through the riser pipe a mixture of water and cuttings. When working well, i.e. when the drilling liquid was not too heavy, and when the end of the riser pipe was no more than 2m above the top of the hole, the pumping action was spectacular. Our particular device dug a 6-inch hole to 18m through hard clay and sand in about 9 hours of work. Subsurface conditions were readily determinable from samples of cuttings suspended in the water pumped out of the riser pipe and from the rate of descent of the tool. The pressure of the column of water in the hole seemed to prevent the immediate collapse of the hole in the sand layers so that like machine augerine one could dig to the bottom of the aquifer.

If one has easy access to about 1000 L of water, this method has some advantages to recommend it, foremost being its simplicity of construction and operation. We suggest the following for use with the installation of 2-inch wells. Use  $1\frac{1}{4}$  or  $1\frac{1}{2}$  inch riser pipe with a 2 inch chamber for the ball check valve. This should dig at least a 3-inch hole. One ought to use settling pits similar to those used with jetting or mud drilling. The pit-around-the-hole arrangement lets too many cuttings fall back down the hole. It is also occasionally necessary to manually fling the pipe back down the hole on the down stroke of the spudding in order to facilitate the pumping of heavy muddy water. With the system illustrated in the AID manual, one gets covered from head to toe with slippery mud. The use of a hose from the riser pipe to the settling pit would eliminate this hazard.

More importantly, we suggest the careful use of water or else casing. We did not use casing and left water in the hole

overnight several times. The wet hole did not collapse, but the walls sloughed off wet clay, and silt suspended in the water settled out, partially filling the hole with mud. If one had dug through the sand aquifer before quitting for the night, the sloughing and settling resulted in the formation of a kind of artificial and impermeable silt right where one planned to place the screen. If at the end of each work session one pumped out the hole completely, and if when one was ready to place the screen, one pumped and then bailed out some of the aquifer sand to be certain that it was clean, one would probably encounter no problems. Easier and more certain would be the use of casing. One could leave water in the casing with no fear of polluting the aquifer, provided again that when one is ready to lower the well inside the casing one pumps out all the drilling water and bails out any cuttings that might have settled to the bottom of the hole.

Casing has been mentioned in numerous contexts here and perhaps deserves some discussion in its own right. If one is working with soft sand and silt formations, one could use 3 or 4-inch steel pipe with a drive shoe and regular couplings. In hard formation one might better use real well casing - heavy pipe with square cut threads and abutting ends. If caving somewhere in the hole is a serious problem, the only other options are jetting, with its risks of not letting you know what is below, or some form of mud drilling with its tricky technical problems. If finding enough water is a problem, one might say that casing is the only solution. As yet we have not used casing to any great extent, having in the South sufficient technology and in the Kanem a fortuitous geological situation. However, perhaps in your search for a technique congruent with both your resources and the geological conditions in your area, you may find it necessary to adopt casing.

## SAMPLE LIST OF TOOLS

- 1) Trucks - Landrover, Saviem, Dodge
- 2) One large tool case with pipe threader, chain wrenches, 24" stilsen wrench, saws, grease guns, suction oil pump.
- 3) One large case with well parts, pistons, check valves, couplings, elbows, nuts & bolts, washers, foot-dogs, reductions, t's, solder & torch, supports.
- 4) Two small tool cases with pipe cutter, wire brushes, fishing tap, keyhole saw, large pliers, chisels, hammers, files, small pipe wrenches.
- 5) Two tool cases with American and metric wrenches for vehicle maintenance, assembling wells, bolting on supports.
- 6) Two inch pipe for the wells.
- 7) Stainless steel Johnson well screens, slot sizes 6,8,10.
- 8) Working pipe, 1" & ½", developing tools, slush pump, surge block, cylinder key.
- 9) Complete well cylinders, with piston & check valve.
- 10) Pump rod
- 11) Pump assembly, wood base & handle, support pipe
- 12) 1½ sacks cement per well, for dalle.
- 13) Pump with suction and discharge hoses, 3 H.P. or larger
- 14) POL, petrol, oil, lubricants.
- 15) Camping equipment, cots, lamps, mosquito netting, water, food, cooking utensils, etc.

## BIBLIOGRAPHY

\*Small Wells Manual, Gibson and Singer, Health Service, A.I.D. Washington, D.C.

\*Ground Water and Wells, Johnson, U.O.P. Johnson Division, St. Paul, Minnesota, 1966.

\*Construction and Maintenance of Water Wells for Peace Corps Volunteers in Technical Assistance (VITA), Schnectady, N.Y., 1969.

Water Supply for Rural Areas & Small Communities, Wagner and Lanoix, World Health Organization, Geneva, 1969.

Village Technology Handbook (CI-11), Dept. of State, A.I.D., Washington, D.C., 1963.

Remote Areas Development Manual, Community Development Counseling Service, Inc., Arlington, Va. 1964.

Ground Water Hydrology, David K. Todd, John Willy and Sons, Inc., New York 1963.

\* These books are probably the most important and useful of the list. Each covers the different drilling techniques, plus development, etc.

## SUPPLIERS

Universal Oil Products  
Johnson Division  
315 North Pierce Street  
St. Paul  
Minnesota 55104

Distributes (manufactures) well  
screens, also in France.

Clayton Mark & Co.  
1900 Dempster St.  
Evanston, Illinois 60204

Manufactures well cylinders,  
pump rods, well screens, fill-  
ings, couplings, and cup leathers.

Goodin Company  
525 North Third St.  
Minneapolis  
Minnesota 55401

Distributes drilling rigs, drill-  
ing tools, couplings, screens,  
cylinders, pipe tools, valves,  
gate and globe, etc.

Dempster Industries Inc.  
P.O. Box 848  
Beatrice, Nebr. 68310

Motorized and electric pumps,  
pump rod and accessories, and  
windmills.

Sears, Roebuck & Co.  
4640 Roosevelt Blvd.  
Philadelphia, PA.19132

Everything!  
Very Useful:  
Power & Hand Tool Catalog  
Suburban, Farm & Ranch Catalog  
Accessories for Mobile Homes,  
Recreational Vehicles &  
Camping Catalog  
Auto & Truck Parts and Accessories  
Catalog

Acker Drill Co., Inc.  
Box 830  
Scranton, PA 18501

Manufactures drilling rigs, bits,  
pumps and related equipment,  
auger tools, core sampling kits,  
and generally related tools.

Mobile Drill Company, Inc.  
3807 Madison Ave.  
Indianapolis, Ind. 46277

Drills, rigs, auger & core  
sampling equipment and tools.

SUPPLIERS (continued)

Sanderson Cyclone Drill Co.  
1250 East Chestnut Street Extension  
Orrville  
Ohio



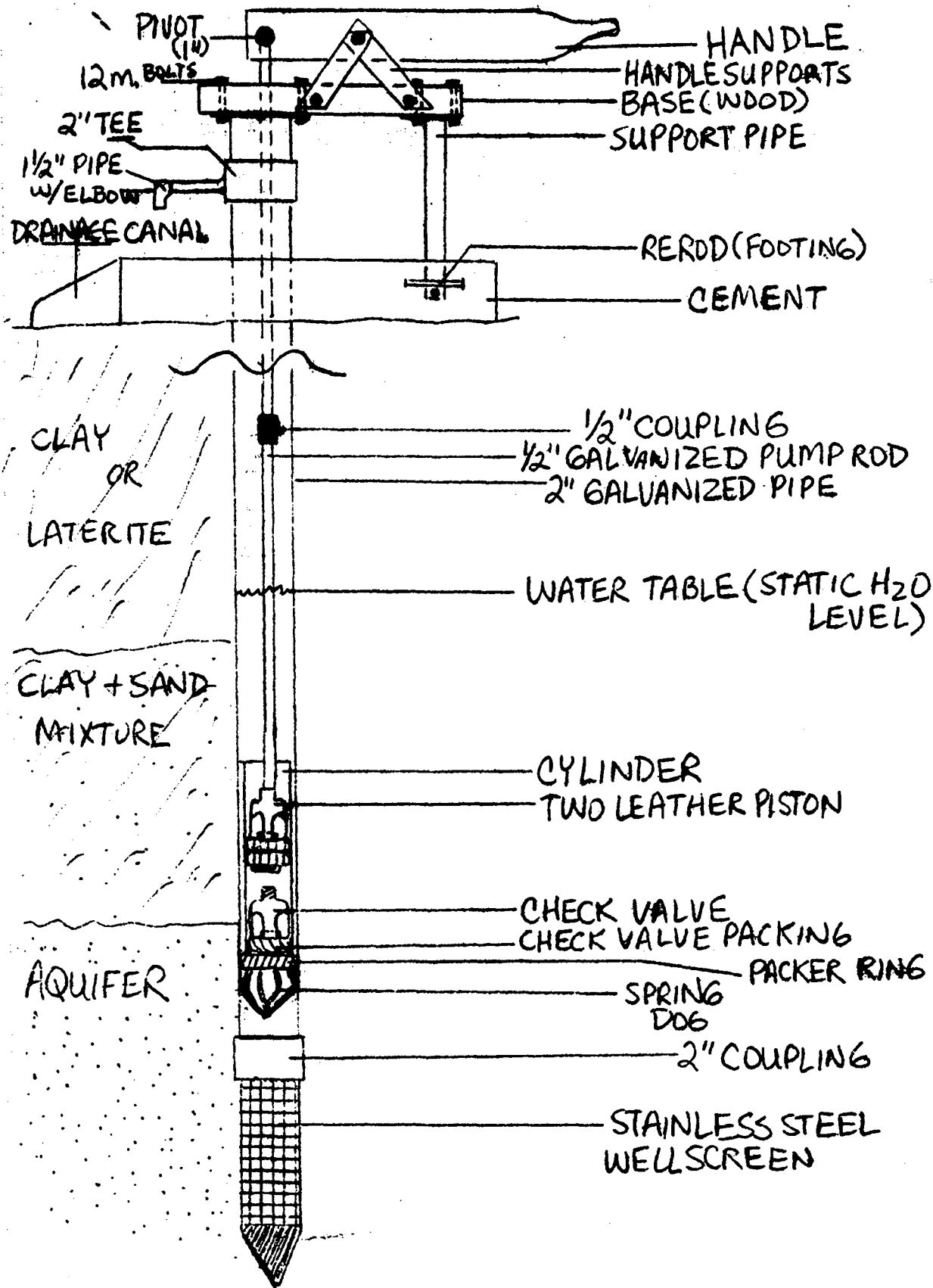

# SLUSH PUMP-

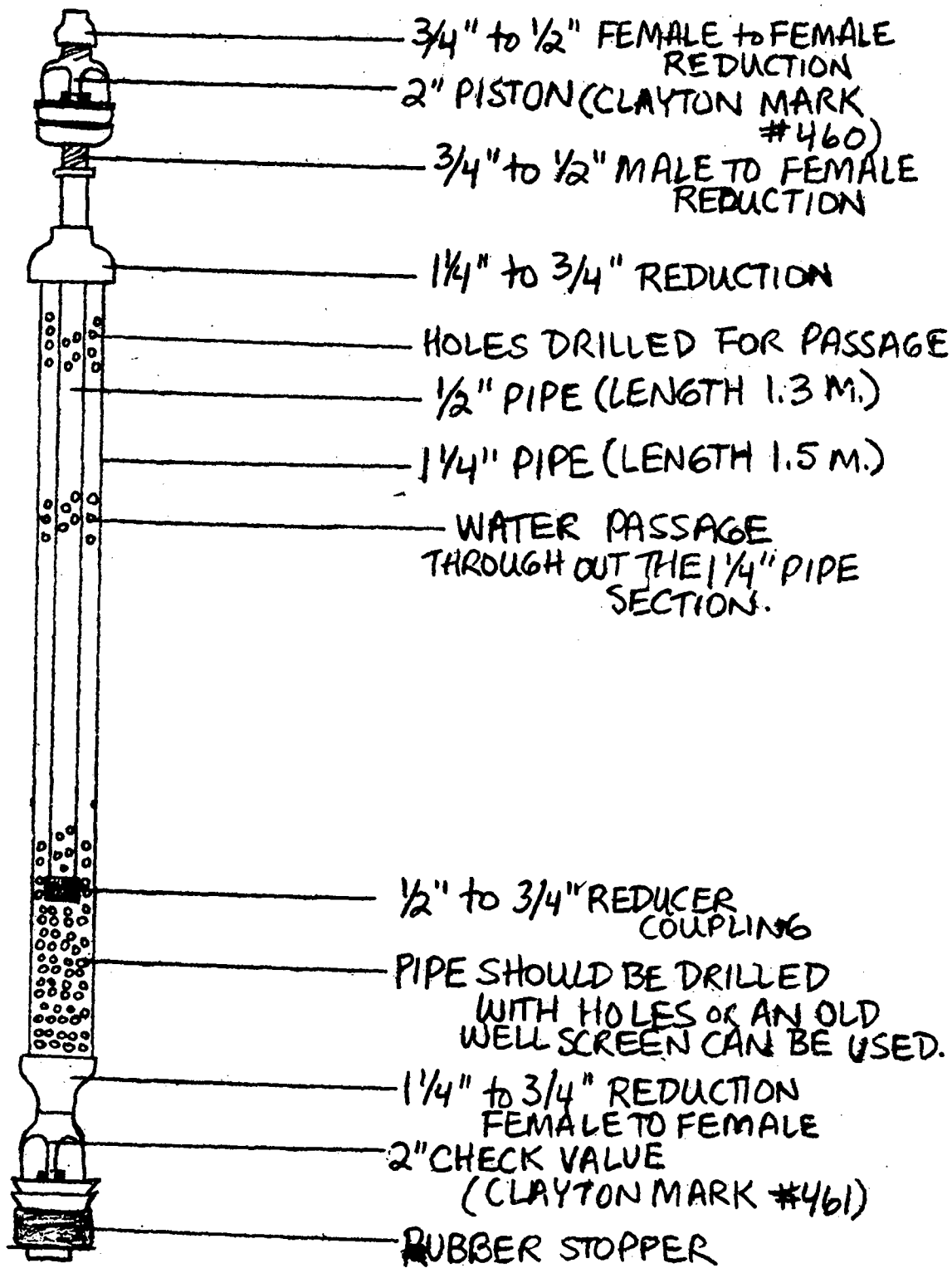

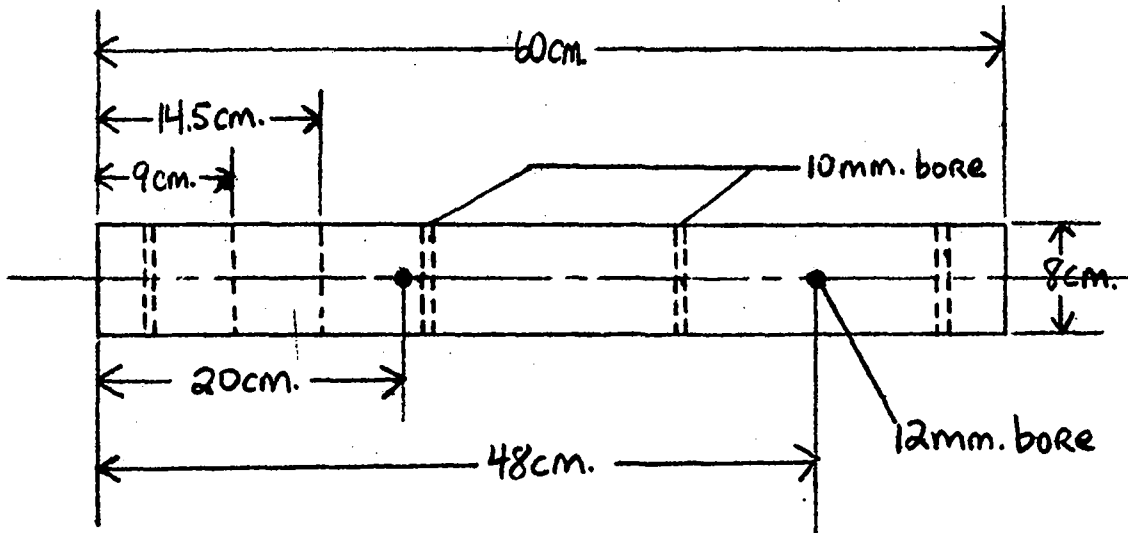

- PUMP BASE -

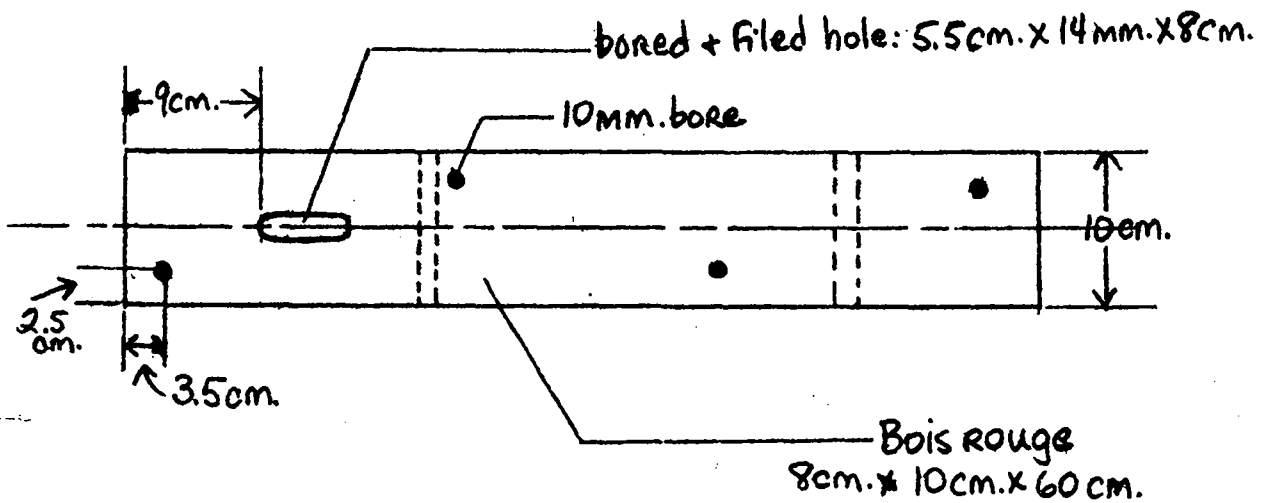

\* IN lining out holes to be drilled (10 mm. bore + tige slot) use same template used for lining out support plates

# HANDLE -

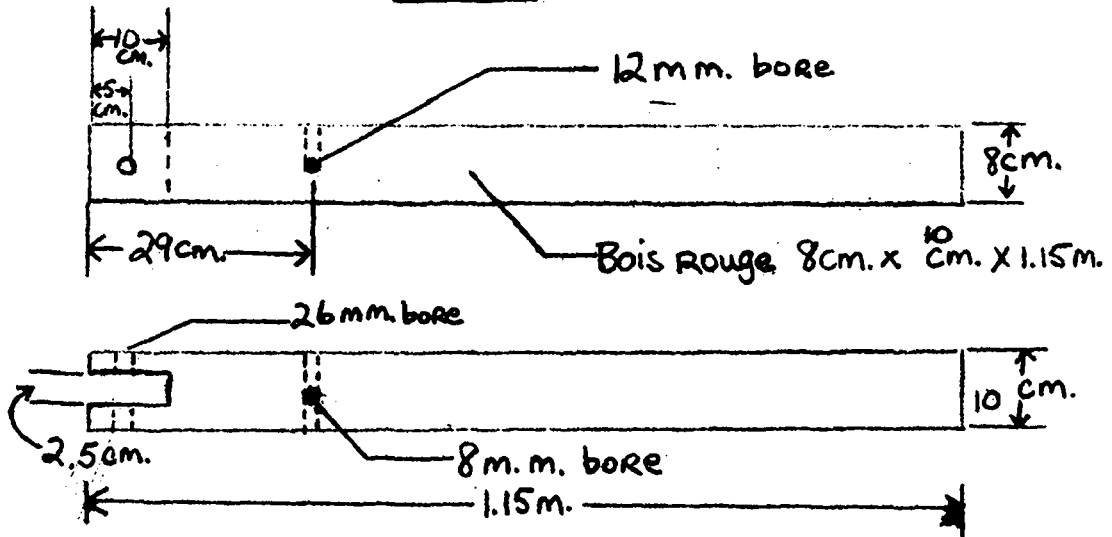

# SUPPORT PLATES -

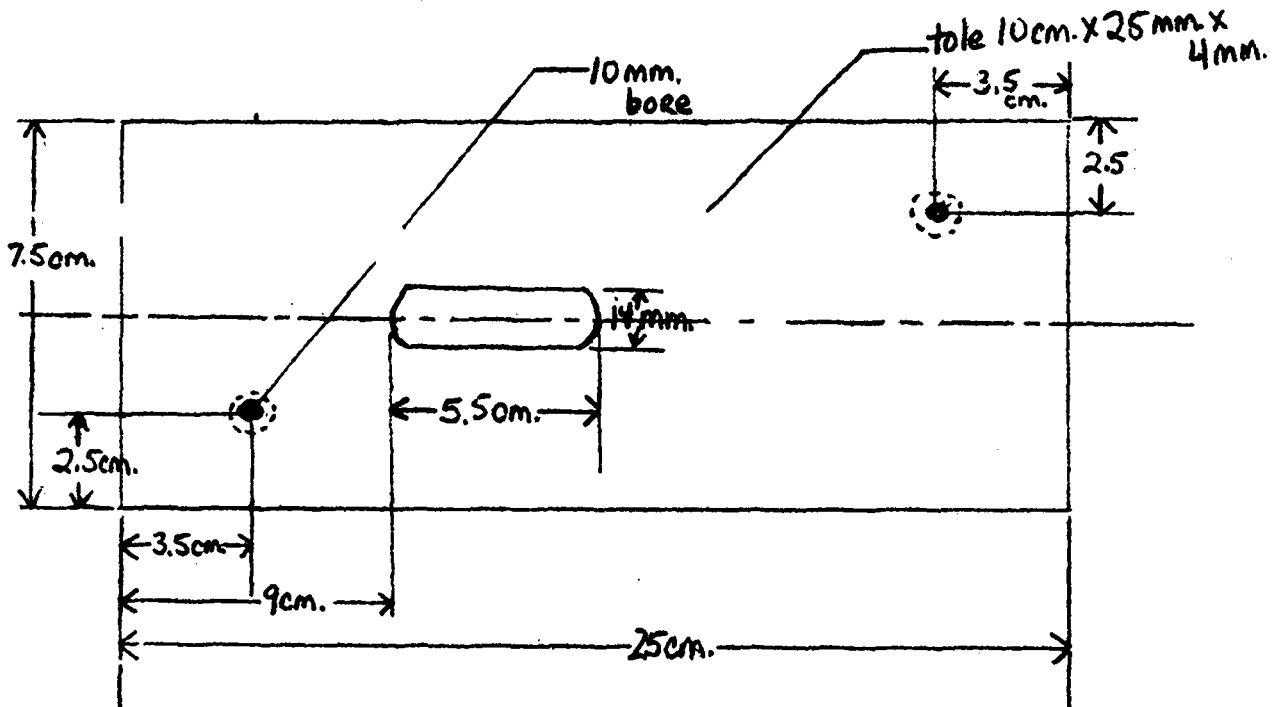

Support Pipe + Plate -

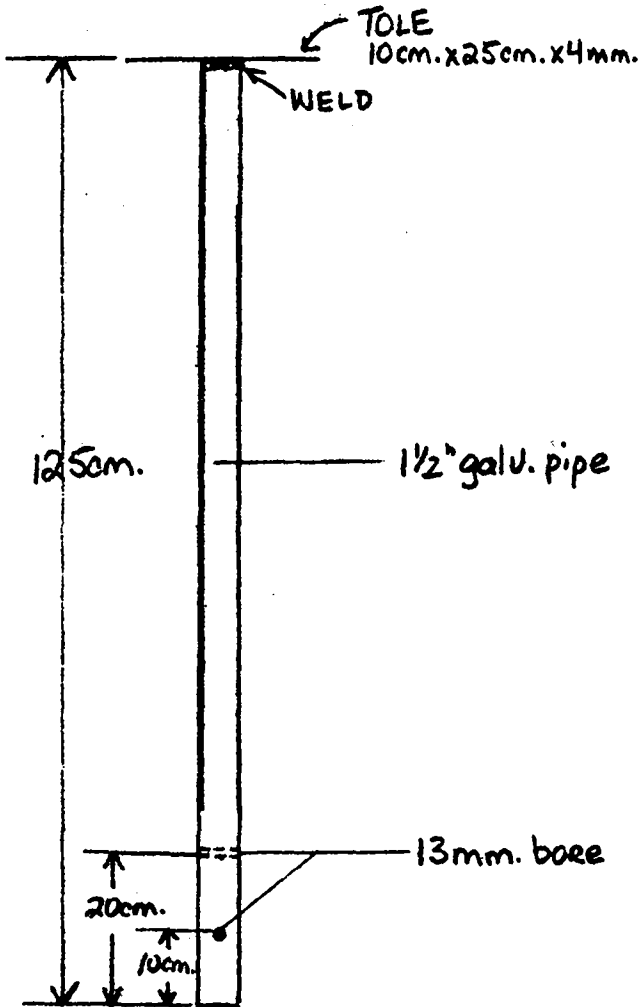
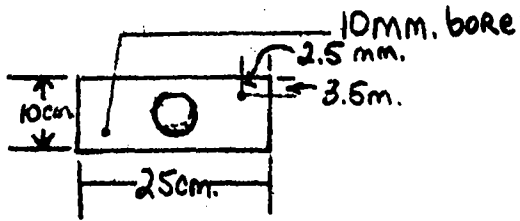

Pivot -

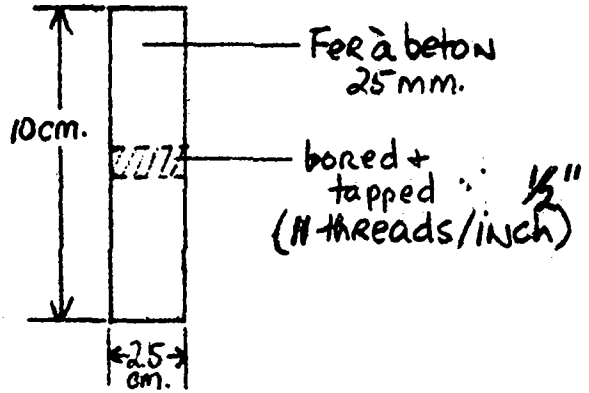

Support Plates for Handle -

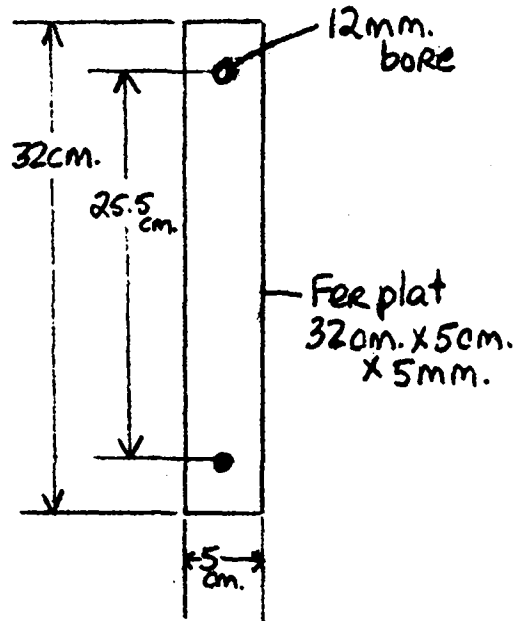

# Robinet Assembly -

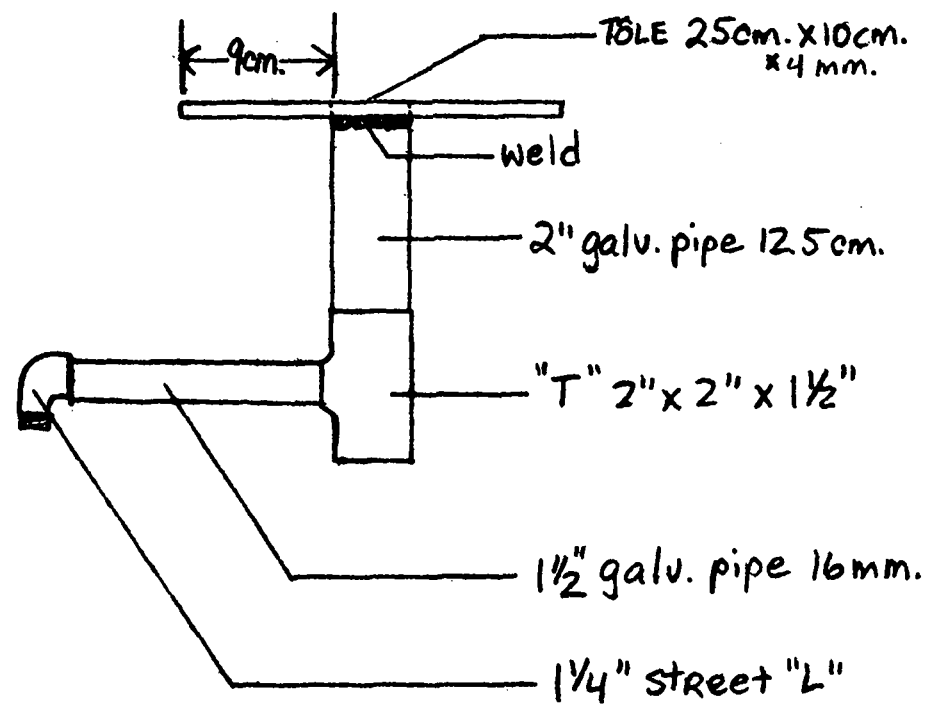

# 2. TOGO, SMALL BORE DRILLING, ATAKPAME-AKPOSSO REGION PCV Louis Jacque DeMoachel 1974

## TABLE OF CONTENTS

- I. INTRODUCTION - PURPOSE
- II. CRITERIA FOR DECIDING WHERE TO DRILL THE WELL
- III. PLAN OF WORK
- IV. PROCEDURE AND PRACTICES (13 steps)
- V. IN CONCLUSION

## ATTACHMENTS

- 1. Cost Estimate per meter
- 2. Equipment for one well/rig
- 3. Sample contract
- 4. Fiche de Puits

## DRAWINGS

- I. Assembled Tripod:
  - A. Front leg
  - B. Sleeve detail
  - C. Back legs extension
  - D. Brace for back legs
- II. Tools:
  - A. Tool attachment
  - B. Auger and 4 inch Drill Stem Bailer
  - C. 3 inch and 4 inch Rock Hammer

*D. Rope Bailer and Fishing Tool*

*E. Casing Clamp*

*III. First Drill Stem - Male Tool Attachment*

*A. Male Attachment*

*B. Female Attachment and Drill Stems*

*IV. Sliding Handle*

*V. Cement Platform*

*VI. Example of an Installation*



## I. INTRODUCTION

The project to be described is being carried out through a joint effort involving a number of agencies:

1. The United Church Board for World Ministries with home offices in New York furnishing the project director and funds for the funding expenses, including 8 Togolese salaries.
2. O.X.F.A.M. Great Britain, grants for capital investment.
3. Togolese Government sponsoring the Volunteers by providing housing.
4. United States Peace Corps furnishing four Volunteers.
5. Association Francaise des Volontaires du Progres furnishing one volunteer.
6. C.R.S. Cathwel providing their offices for duty free wells supplies imports, plus helping to pay a part of the salary for a Canadian welder/mechanic.

Local address: Projets Techniques Sociaux  
Eglise Evangelique du Togo  
B.P. 79  
Atakpame

Purpose: to provide a year-round supply of drinking water for village people, and, if possible, for their other domestic needs in the village or as near to it as possible to eliminate carrying water long distances.

## II. CRITERIA FOR DECIDING WHERE TO DRILL A WELL

An effort is made to locate the well in the village itself so long as there is good surface drainage. If this is not practical, drilling may then be attempted down slope but no more than 100 to 300 meters from the village. The drilling team checks for location of old and new W.C.s, garbage pits, etc. and stays at least 35 m from these contamination sources. Attention is paid to old wells, the lay of the land, direction of the nearest creek bed, types of plants growing, etc. Villages are usually located on a hill. It is a good idea to walk to their present drinking water site and study soil formations on the way. A short excursion along a nearby stream can help in locating a drilling site.

No attempt is made to call in water diving experts, but if there are such people in the area, their advice is considered. When geological maps are available, they are also used.

### III. PLAN OF WORK

The drilling crew consists of two men, the job foreman, and his assistant. The drilling equipment is furnished by project funds. Power to operate the equipment is furnished by the village or group for whom the well is being dug.

Usually, village leaders ask that a well be drilled in their village. The conditions to be met by the village before the start of the drilling operations are then explained. Briefly they are as follows:

1. Currently, the village or group must agree to a total contribution of 20,000 frs. CFA. 10,000 frs. is received by the job foreman before work begins and the remaining 10,000 frs. before making the installation after a successful test pump. It must be emphasized that this amount is only a contribution by the village. Average costs per meter of well depth are approximately 7,500 frs. and this does not include the cost of the hand pump. The fact that the people must pay for part of the well costs places more importance on the project and consequently they will be more interested in taking care of their pump after its installation. It is important for the people to feel that the well is theirs and that maintenance is their responsibility. Normally, someone in the village is put in charge of the pump. The drilling crew instructs this person on maintenance.
2. The village must furnish eight men per day for the work. They can be volunteers or the village pays them.
3. The village must agree to furnish food and lodging for the two-man drilling crew during the drilling operation.
4. Work hours and other details are arranged with the village.
5. A responsible person in the village signs a contract explaining all the above details and, after this, work can begin. (See attached contract form).

### IV. PROCEDURE AND PRACTICES

Once a site has been chosen, drilling equipment is set up and drilling begins. This equipment is practical for drilling wells up to 30 m in depth).

1. The tripod is raised and leveled. A plumb bob from the apex of the tripod should touch a point on the ground equi-distant from the base of the three legs providing the three legs are equi-distant from another. The guide for the drill stem, located on the cross-bar of the tripod (see tripod diagram) should then line up with the plumb.

2. With a spade, start the hole. Usually 30 cm depth is sufficient.
3. Connect the auger to the first drill stem (see tool diagrams) and place it in the hole you have just made. With the drill stem in the guide on the cross-bar, (see tripod diagram) fasten the guide latch.
4. Attach a rope to the drill stem and through one of the two pulleys at the apex of the tripod.
5. Attach a sliding handle to the drill stem and you are ready to begin work.
6. Two planks 2 m x 30 cm x 5 cm are placed at either side of the hole to protect it from caving and provide a platform. Initially, if conditions are dry, the auger is forced down by adding weight and a small quantity of water as needed. Two to four men place themselves on the sliding handle and four men turn the auger back and forth. (Turning only in one direction will cause the rope attached to drill stem to become tangled). As the auger fills with soil, it must be brought out and cleaned. The quantity of soil that can be removed at a time depends on the type of soil. Normally, this is 20 to 50 cm of soil in the auger. When the auger no longer descends, remove it, and, with drill-stem attached, place it on the edge of a wooden block for cleaning. The drill stem rests on the tripod horizontal brace. For cleaning, a 12 mm bent rod is satisfactory. After cleaning, replace tool and continue drilling. Usually, when the full length of the auger is in the ground, it will act as a guide and the men riding on the handles to add weight will come down, and the normal drilling action can start. Two men at the handles twist the auger back and forth while the men at the rope lift and drop the tool. The tool and drill stem is raised 70 to 100 cm each time before dropping. As the auger descends, it will be necessary to change the position of the sliding handle. This is accomplished by loosening, repositioning, and retightening the handle bolts. Twenty foot drill stem sections are added as needed. If the soil is dry, it will **not** come out with the auger. To remedy this, a small quantity of water is used to get the right consistency that will stick to the auger. The right amount of water to use must be determined on the job. When bringing out sections of drill stem and the drill stem with tool, the notched safety plank is put into position, and the pipe-vice is used to hold the drill stem at the desired height. Avoid accidents! Tie cord to the flat open end wrenches that are used to tighten bolts so that they will not be lost in the bore hole.
7. When rock is encountered, the auger is replaced with the 130 mm star rock hammer in order to break it up. Here again, water is added to produce a slurry that can then be brought out with the 115 mm sand bailer. The larger diameter tools are used as long as possible. If

the rock is very hard, (quartz or granite) and progress slows to only 20 to 50 CM per day, work is continued for perhaps 2 to 5 days, depending on the type of rock and the desire of the village people. After 50 cm in hard rock, one can usually tell if it is a solid layer or if it is only an underground boulder, hit by chance. The boulder usually breaks up (shatters) and the work continues. The auger is again used for drilling because it is much faster. NOTE: Best action with the rock hammer is short, rapid strokes (50 cm). Continue hammering for 50 to 100 strokes before boiling.

8. Caving Situation: When caving sand or mud is encountered, it is very important to note at what depth caving begins, since this measure is necessary when deciding what type of installation to make. Also note type of caving material, i.e. clay, sand, etc. It will now be necessary to lower the 4 in. galvanized pipe into the bore hole in order that drilling can continue inside the pipe or casing. This casing remains in the hole until the drilling operation is complete and is then replaced with 2 inch galvanized pipe and stainless steel drive point or high pressure plastic pipe 80-90 mm. above ground so that it can be removed at any time. Casing sections are added as drilling continues. Of course, the smaller hammers and bailers (100-90 O.D.) are used. Usually the casing will descend by its own weight. If rock is encountered, do not force the casing down as it will be very difficult to remove and may be damaged as well. In addition, the rock may be the source of water and since it will not cave, there is no need to case it.

However, if the rock is only a shallow layer or boulder and drilling must continue below it in a new caving formation, the 4 in. casing must then be forced down past the rock so that normal drilling can continue. For forcing the casing down, a wooden block is placed on the casing to protect it before tapping with a sledge hammer. An alternative method is to use the rock hammer attached to the drill stem which is then raised and dropped with the rope and pulley. In this case, a sliding handle is clamped to the drill stem and it is the sliding handle that strikes two wooden blocks placed on either side of the drill stem and on top of the casing. The rock hammer itself is inside the casing, serving to guide each blow while at the same time providing the weight needed.

Note: Removing the galvanized casing. The galvanized casing is part of the drilling equipment and does not remain in the hole. The same casing is used again and again, as needed.

However, before removing the 4 in. galvanized casing, the 3 in. plastic or 2 in. galvanized casing must be put in place. The choice of materials depends on the situation, but currently we are using the 2 in. galvanized pipe in most cases because it is a very dependable installation.

Usually, the casing is lodged in the hole because of the caving formation and must be brought out by force. This is accomplished by using two 6 or 8 ton hydraulic jacks placed under the heavy clamp that has been fastened around the casing and slowly jacking out the casing. Place wooden blocks between jacks and clamp to gain more height and reposition clamp if necessary. Continue jacking until casing is free and can be pulled out with the rope and pulley.

9. Fishing tool (see diagram): Inevitably, a tool will stick in the bore hole; a rope will break or it will be necessary to retrieve pipes from the well. To remedy any one of these situations, a tool made of heavy rod (20 mm) with a spear hook and a socket welded to the opposite end, will be necessary. The socket is bolted to a section of the drill stem and thus can be lowered into the well to hook the tool or pipe and pull it out. The tool should be about 3 m long.

Magnet: In spite of all precautions taken, eventually a bolt or other foreign metal object may be dropped accidentally into the well. A strong magnet is needed to retrieve these lost items.

10. Depth of aquifer: Once water is reached, continue drilling as long as practical to take full advantage of the total depth of the aquifer. For a bored well, this is important as it will normally increase the amount of water that can be drawn from the well. Ideally, drilling should continue until 3 or 4 meters of water can be measured. Some aquifers are shallow (30-60 cm). In this case it will be desirable to continue drilling to reach a second aquifer.

11. Test pumping: When the sand bailer can no longer bring out all of the water in the well and the depth of water measures 3 or 4 meters (fully charged), it is advisable to test the well and check the output (litres per hour) before planning an installation. 500 to 1,000 litres per hour is considered sufficient for hand-pumping situations, provided that the water flows back quickly when the well has been pumped dry. (It should recharge in 15 minutes). It is advisable to have a simple test pump for this procedure which can be put down and removed quickly. This depends on the type of pump available for the permanent installation.

Test pumping procedure: The object is to pump the maximum number of buckets per hour.

Example: A #34 bucket equals 17 litres. If 50 buckets can be pumped in one hour, the well yield is 850 L/hr.

12. Pump installation: No attempt will be made to give full details here. The "Small Wells Manual" by Gibson and Singer or other similar manuals give detailed information. We will explain our approach to this part of the drilling operation according to our situation.

After satisfactory test pumping, a decision must be taken as to how to install. This depends on water bearing strata and formations above water. Water in very fine sand may require a 10 slot or even 6 slot screen and a gravel pack. It is advisable to case the well completely to prevent caving. This is accomplished with the 2 in. galvanized pipe fitted with a stainless steel sandpoint. Or if the aquifer is shale (water bearing rock) a simple foot valve may be all that is necessary.

A bore hole 6 meters deep or more must have a deep well cylinder. This cylinder is actuated by a pump rod connected to the pump handle above ground. The cylinder is located in the bore hole no more than 3 meters from the bottom of the well. It consists of a plunger with leathers and valve, and a foot valve or check valve.

A well screen, suction strainer or foot valve is fitted below the cylinder according to the situation. When using a gravel pack, screens are needed to prepare a pack of uniform size. See detailed explanation in wells manual. If you have a sand gage, it will help to determine size of gravel pack material.

13. Sanitary installation: It is essential that no surface water or other polluting materials can enter the well. To assure that the well does not become polluted, the type of installation is important. There are of course different ways of making a sanitary installation. The current method being used will be explained here. (See diagram).

A simple rugged hand-pump is used in conjunction with a deep well cylinder to bring the water to the surface. Because of the possibility that a new well may have to be deepened or need major repairs after several years of use, the technicians are presently using 5 in. I.D. fibre cement pipe and placing it to a depth of 3 meters in the bore hole. It may be necessary to ream the bore hole to allow enough space between the 5 in. pipe and the bore hole is well sealed with a cement grout to the full 3 m depth of the large casing. (If surface soil is heavy clay, this material can be tamped in solidly and will do the same job as the cement below 1 meter from the surface. However, the remainder of the space to the top of the well must be sealed with a cement grout.

A concrete apron or platform 120 cm square is poured above ground. This apron is 8 to 9 cm thick but raised to 30 cm above ground to assure proper drainage away from the well. A small foundation around the perimeter of the apron is dug to a depth of 35 to 45 cm and is 10 cm thick. The hand-pump is fastened to bolts that are placed in the concrete apron when it is poured. With the pump bolted into place, a sealed well has been produced. (See accompanying diagrams).

Disinfect the pump and pipes with a strong solution of bleach before using it.

Water samples from new well should be analysed before allowing a village to use the water for drinking. This is not always possible but at least spot checks should be made in a given area. Polluted underground streams are always a possibility in shallow wells of less than 6 meters.

- V. In conclusion: Once a sanitary installation is made and the well is producing abundant drinking water, one is tempted to think that the job is finished. On the contrary much remains to be done! This takes the form of maintenance training and close supervision in the beginning until the village people responsible for maintaining the pump have learned how this is done. Pump installations must be visited frequently by the technicians during the first few months to make sure that the pump is properly cared for. The person responsible for the village pump needs a supply of grease and oil to lubricate the pump and also simple wrenches for tightening bolts.

A pump improperly cared for can be ruined in one week. On the other hand, with normal maintenance, it can last for years. The digging of a well may take only 2 days or several weeks. Patience is needed, especially with the village population for whom the operation is completely new.

Important: When drilling, all soil formations encountered are noted and an accurate detailed diagram of each well installation is made. This is essential for future reference. (See accompanying drawing form).

OUTILS FORAGE DES PUIITS (suite)

Details de la connexion  
la même que pour le Tarière  
de Sondage

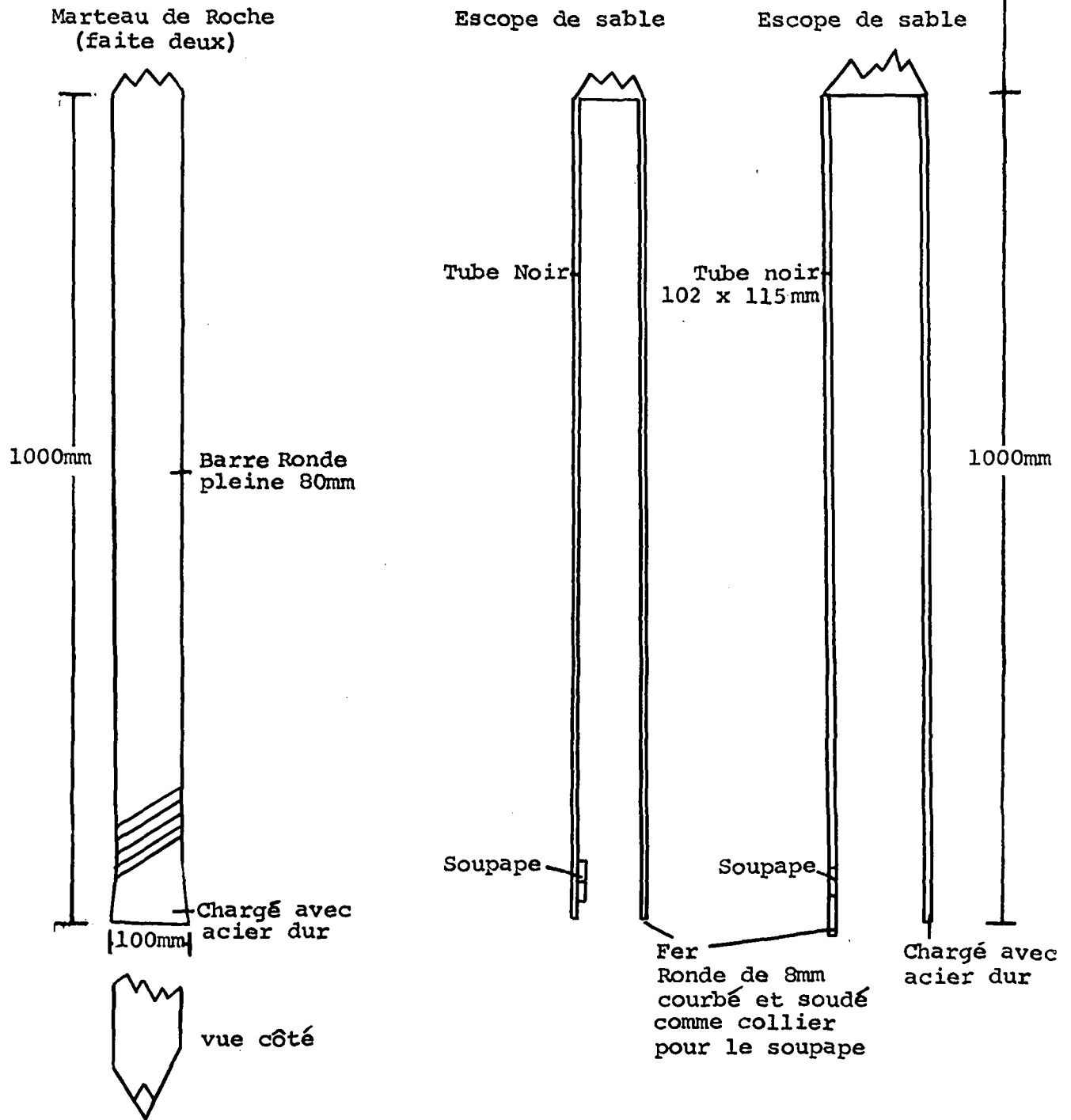



# TIGE DE FORAGE

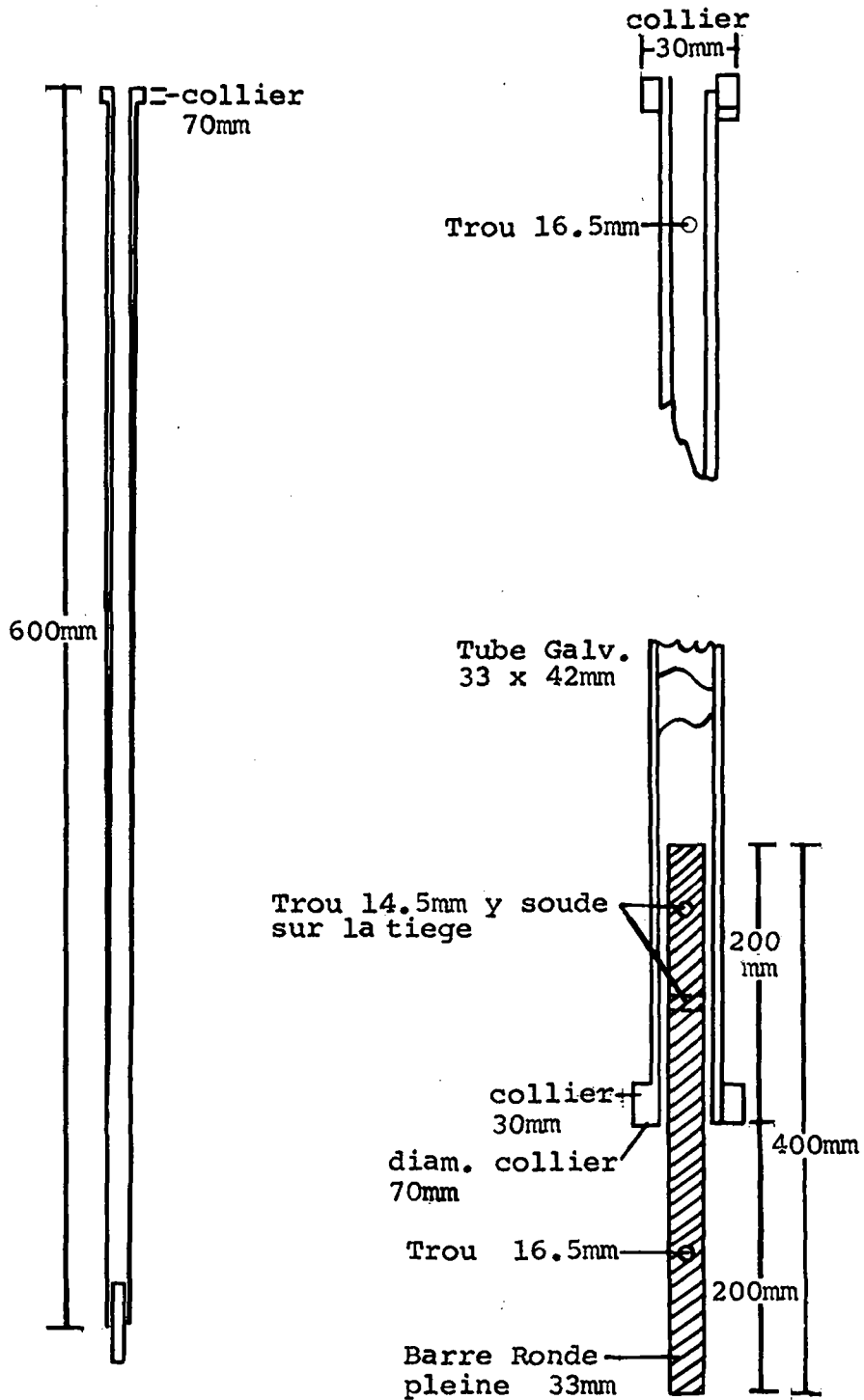

NOTE: La premiere tige qui s'attache aux outils:  
Dans la barre pleine ronde de 33mm, faire deux  
trous de 14.5mm.  
Conformé avec les trous dans la connexion des outils.

ESCOPE DE SABLE POUR LA CORDE

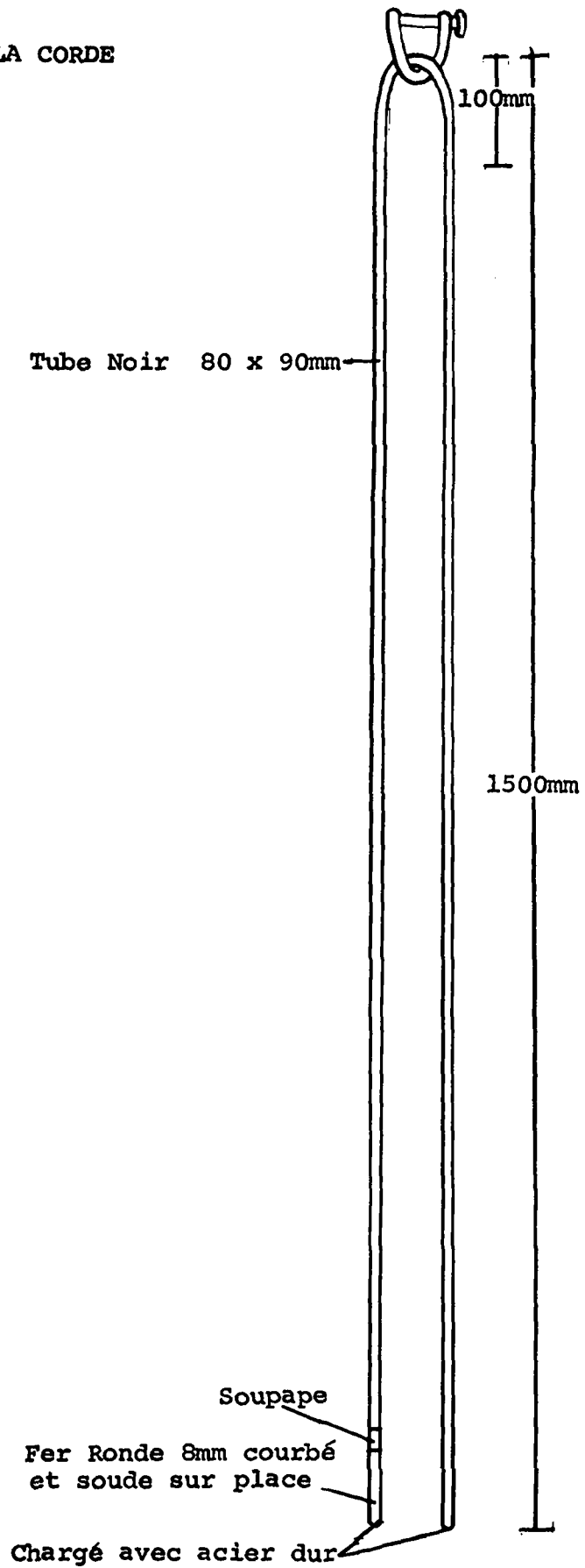

1/A

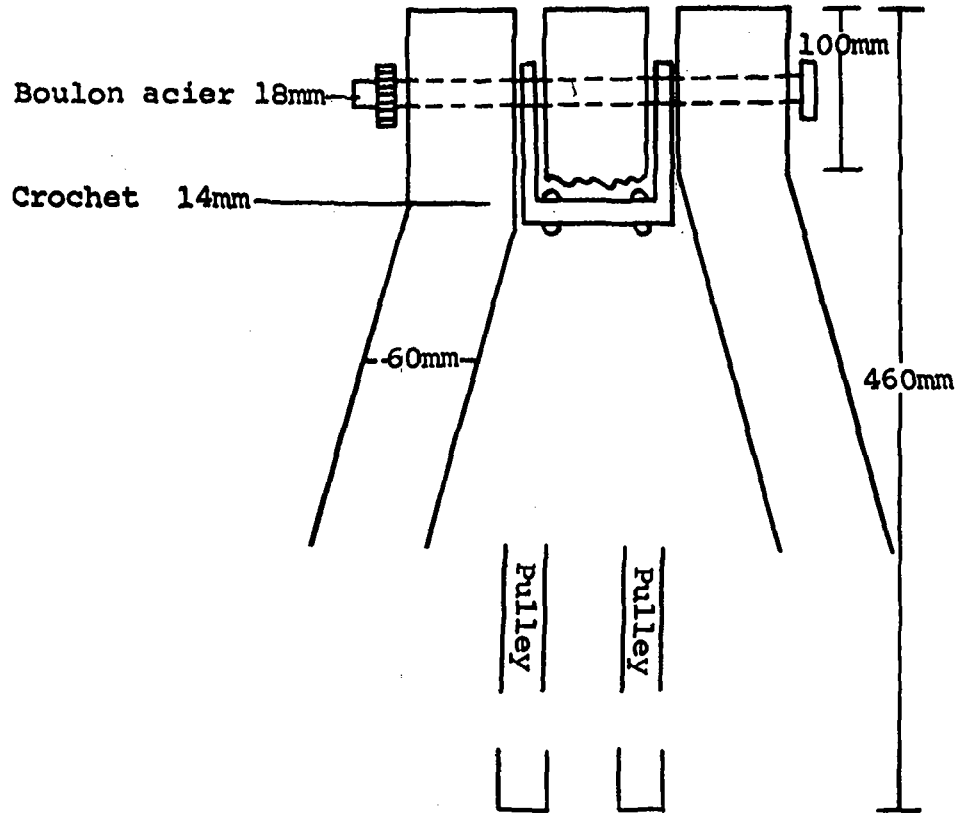

1/B

Tube Galv.  
70 x 80mm

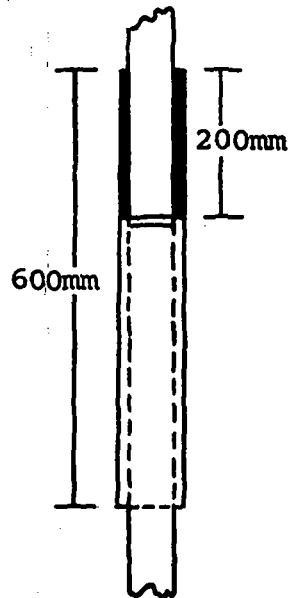

CRAMPON POUR LE COFFRAGE DE 4 POUCE 9102 x 114mm)

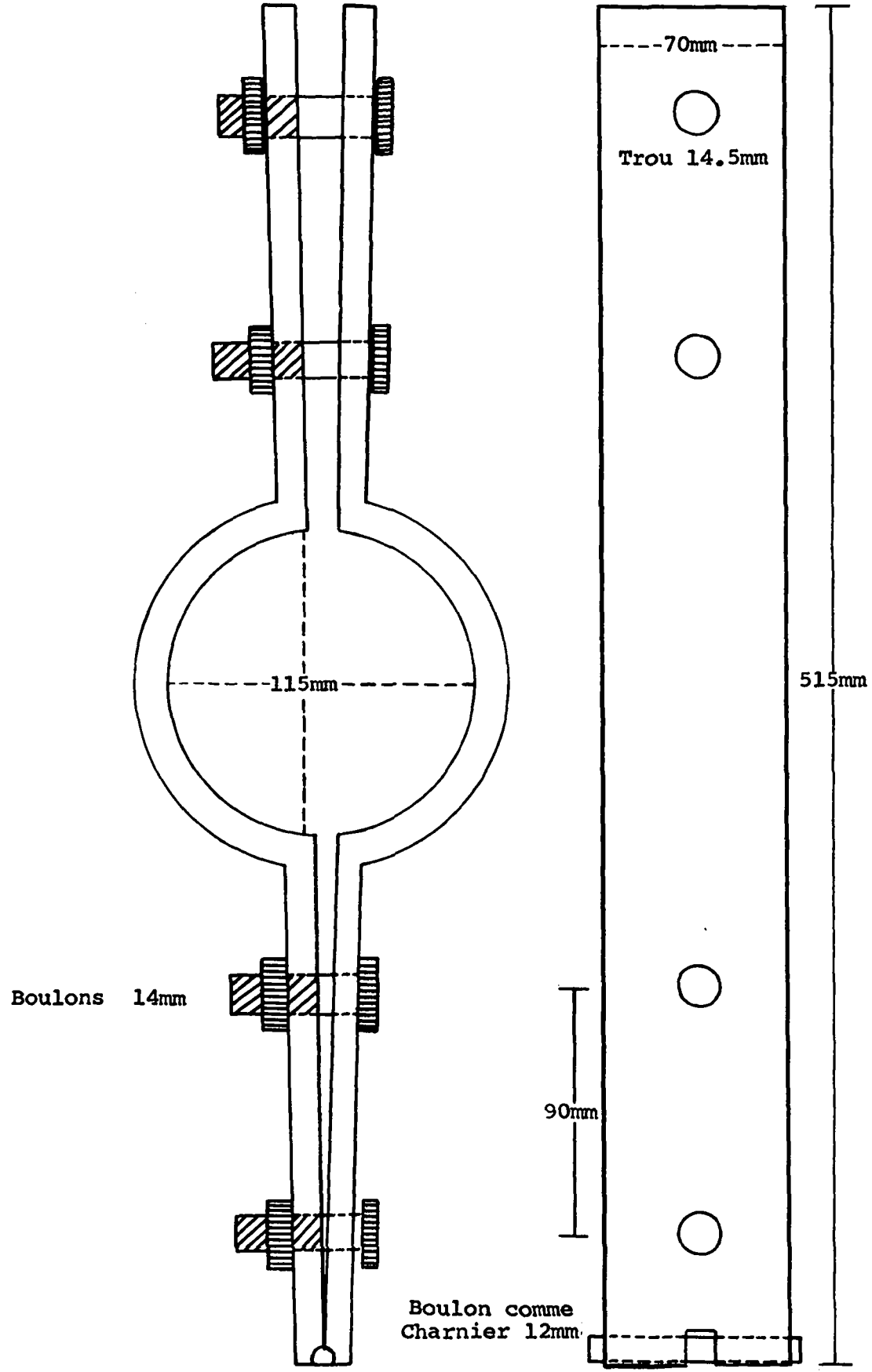

Trois Pieds Équipement  
de Forage des Puits

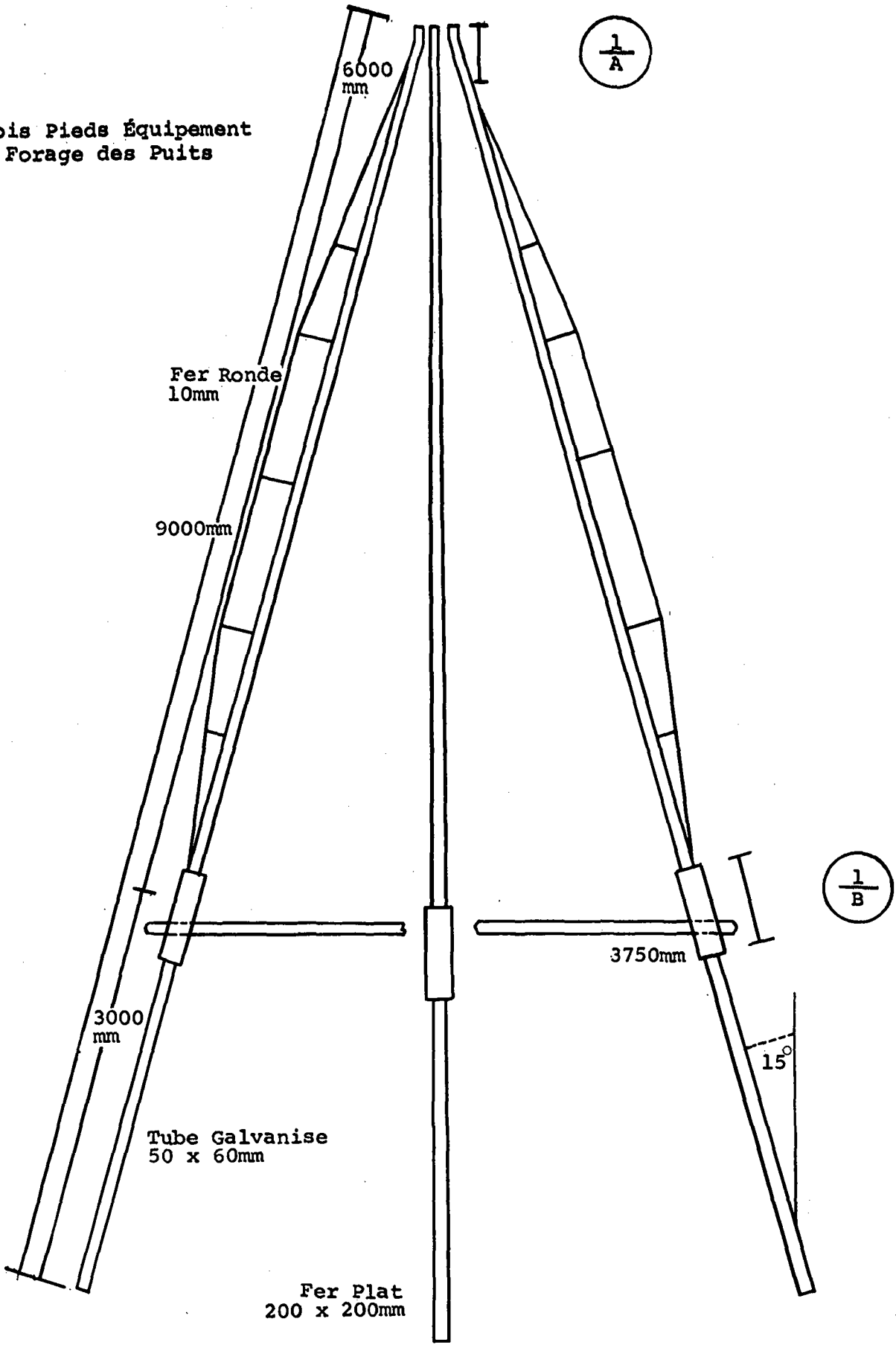

OUTILS DE FORAGE DE PUIITS

Centre rurale Kounyowu  
TOGO

Tarière de Sondage  
(faire un)

Marteau de roche  
(faire un)

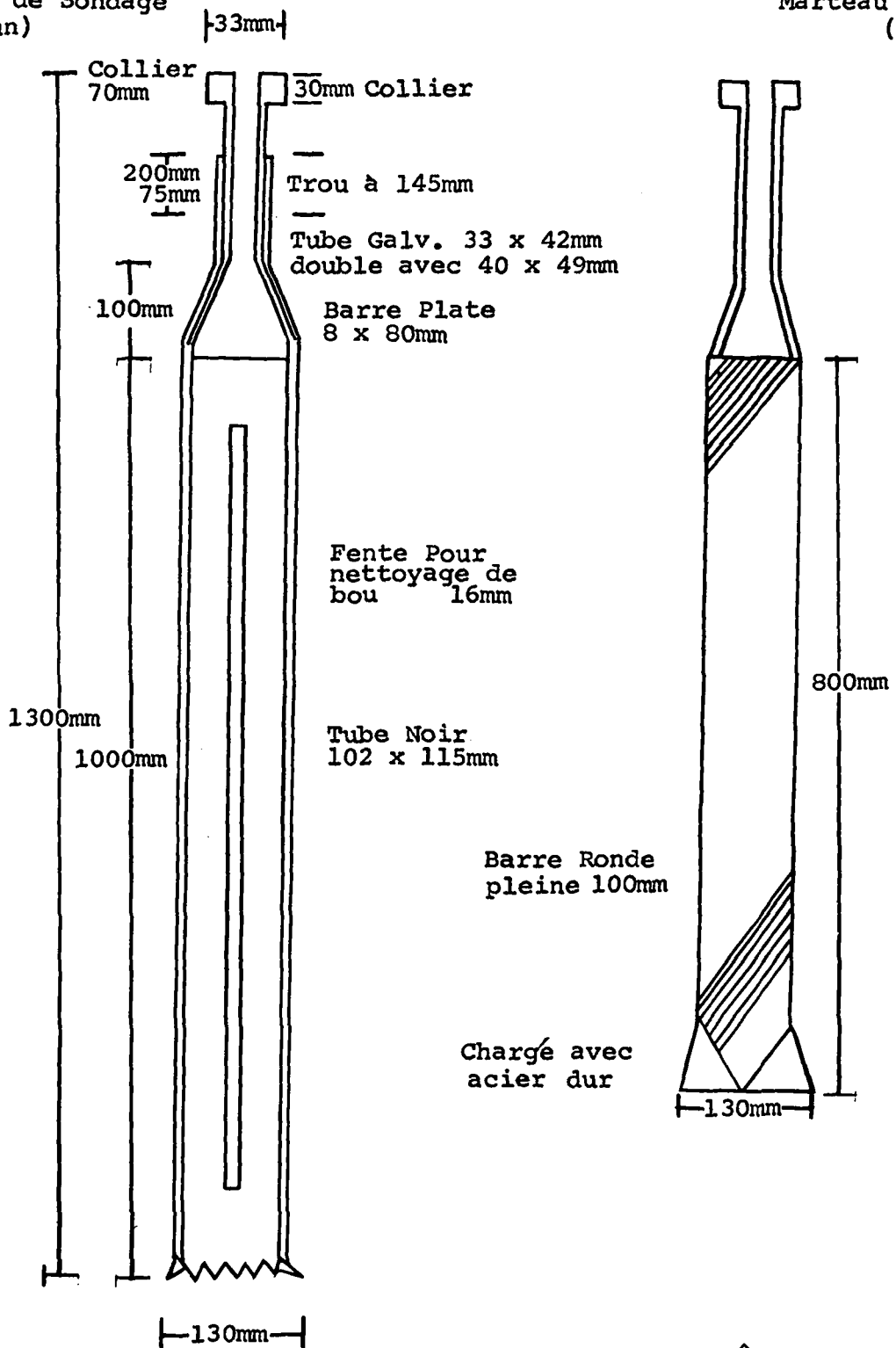

vue d'en bas 

# 3. TOGO, COST ESTIMATES PER METER SMALL BORE WELLS PCVs Togo 1974

(240 CFA = \$1.00)

|   |               |
|---|---------------|
| A. Well depth from 6 to 15 meters (taking 10 m as average depth)  |               |
| 1. Moving costs and return trips for repairs and installations using 60 km as an average distance and three trips we have 360 km x 25 Frs CFA | 8,900         |
| 2. Salaries for two Togolese including transport costs for one month (salaries continue for dry holes too)                                    | 30,000        |
| 3. Repair costs (welding rod, gas, metal stock)   | 1,000         |
| 4. Materials costs for pump installation without cost of pump itself (10 m depth) 2 in. galvanized pipe = 670 frs/M                           | 6,700         |
| 1 in. galvanized pipe = 340 frs/M   | 3,400         |
| Stainless stell filter 2" x 24"   | 11,500        |
| 1-13/16" brass cylinder   | 8,000         |
| Cement (3 bags)   | 1,800         |
| Fibre cement pipe 5" x 3M   | <u>1,400</u>  |
|   | 72,700        |
| 5. Plus 20% for depreciation on equipment   | <u>14,540</u> |
| Making a total cost per meter of 8,724  | 87,240 CFA    |
| B. Well depth from 15 M to 25 M (taking 20 M aver. depth)   |               |
| 1. Moving costs and return trips for repair and installation using 60 Km average distance to work site. 4 trips gives 480 x 25 frs.           | 12,000        |
| 2. Salaries for 2 Togolese including transportation costs for 6 weeks.  | 45,000        |
| 3. Repair costs (welding rod, gas, metal stock)   | 2,000         |
| 4. Material costs for pump installation without cost of pump itself (20 M depth)  |               |

|                                   |              |
|-----------------------------------|--------------|
| 2 in. galvanized pipe = 670 frs/M | 13,400       |
| 1 in. galvanized pipe = 340 frs/M | 6,800        |
| Stainless steel filter (2 in.)    | 11,500       |
| 1-13/16 in. brass cylinder        | 8,000        |
| Cement 3 bags                     | 1,800        |
| Fibre cement 5 in x 3M            | <u>1,400</u> |
|                                   | 101,900      |

5. Plus 20% depreciator. 20,380

Making a total cost per meter of 6,140 frs/ 122,280 CFA

### Drill Rig Costs

The material for the drilling rig we use cost about \$500.00 here in Togo and then whatever it costs to have them made up. We have seven sets costing \$800.00 for each set, including materials and fabrication costs. In addition, the necessary small tools, vice, threaders, etc, bring the total cost for one rig to \$1700.00. A two ton light truck with overhead rack can haul this equipment. The equipment is very portable and simple to use. The tripod can be raised in 5 to 10 minutes. However, a portable welder is essential so that repairs can be made at the site. When in hard rock, the hammers must be re-surfaced frequently. We have one portable welder for our seven rigs.

### Hand Pumps

General: We have not settled on a standard pump yet but at present, we think that a well from 15 to 30 meters deep needs a heavy duty pump. We have ordered 25 heavy duty pumps from Abidjan called the ABI, but they have not yet arrived. These pumps cost approximately \$300.00 each plus transport. The manufacturer says they are designed for wells up to 50 M deep.

For wells under 15 M, we can use the simple American "Monitor" pump costing only \$65.00 including transport. We do have to modify the wear point between the handle and the pump rod on this pump.

### Hand Pump Types used in the Project (Atakpame, Togo)

#### Bodin Majestic M3 Hand Lift Pump (French)

1. This pump is generally well designed and will give years of service if properly maintained. If not greased, it will wear out in a few months in spite of its rugged design. It works easily to depths of 30 meters.



2. However, the base bolts must be checked regularly to avoid leakage.
3. In addition, we find the price quotation unreasonable: \$280.00 for pump only.

Monitor Lift Pump for Wind Mill, pump jack or hand pump use (U.S.)

1. This pump was not designed for daily hand use as is encountered in a village. The pin connecting pump rod to handle wears quickly. We have modified one of these pumps by welding in a ball bearing and it is giving good service. The pump is very easy to install and it can be repaired if a welder is available.
2. It is ready to be attached to a windmill or pump jack. For these types of installation, it will give years of dependable service.
3. This pump including transportation costs about \$65.00.
4. For hand pumping, we recommend it up to depths of 15 meters or with a small 1 13/16" deep well cylinder, up to 20 M.

Monitor Lift/Force Pump

Same as above except it is fitted with a packing nut, shut off valve for spout, and is tapped to receive an outlet pipe for forcing water to an overhead tank. It costs \$75.00. Replacement parts are simple and very inexpensive.

Nigerian Foundaries Limited - Lagos

They have an experimental pump similar to the Monitor pump with a tapped steel block at the main wear point. We don't have enough experience with this pump as yet but it does show promise. The workmanship on this first model was poor. Again the cost is unreasonable for the equipment furnished, being approximately \$115.00.

TOGO: Equipment for one well rig - Bore Hole Project

A. Drilling Tools

| <u>Qt.</u> | <u>Item</u>                       | <u>Dimensions</u> | <u>Materials</u>                              |
|------------|-----------------------------------|-------------------|---|
| 1          | Earth Auger                       | 1300 x 115 m/m    | black pipe 6 mm                               |
| 1          | Rock Hammer                       | 1100 x 100 mm     | solid steel bar round                         |
| 2          | Rock Hammers                      | 1300 x 80 mm      | solid steel round bar                         |
| 1          | Sand Bailer                       | 1300 x 115 mm     | black pipe 6mm                                |
| 1          | Sand Bailer                       | 1300 x 90 mm      | Black pipe 6 mm                               |
| 5          | Drill Stem                        | 6000 x 42 mm      | Galv. pipe 33x42 mm                           |
| 1          | Tripod                            | ht. 9000 mm       | Galv. pipe 50x60                              |
| 4          | Galv. pipe (casing)               | 6100 x 115 mm     | Galv. pipe 10x115 mm                          |
| 11         | Pipe couplings                    | 4" 102x115        |   |
| 1          | Pipe clamp for 4" casing          | 515 x 70 mm       | flat iron bar 70x10mm                         |
| 2          | Sliding handles for<br>drill stem | 1000 x 100 mm     | flat iron bar 100x8mm<br>and galv. pipe 33x42 |
| 1          | Safety notched board              | 500x300 mm        | Plank 50 mm                                   |
| 2          | Platform boards                   | 2000 x 300 mm     | Plank 50 mm                                   |
| 2          | Pulleys                           | 25 x 90 mm        | Steel   |
| 1          | Vice with bench capacity          | 130 mm jaw width  | 150 mm steel                                  |
| 2          | Rope                              | 35000 x 16 mm     | manilla rope                                  |
| 1          | Fishing tool                      | 3 m long          | 20 mm rod                                     |

B. Small Tools and Other Equipment

|    |                             |                 |                   |
|----|-----------------------------|-----------------|-------------------|
| 2  | Hydraulic jacks             | 6 to 8 ton cap. |                   |
| 1  | Spade                       |                 |                   |
| 1  | Expanding double meter      | measure         |                   |
| 1  | Water pump pliers           | 20 in.          |                   |
| 1  | pliers                      | 6 in.           |                   |
| 10 | Metric end wrenches         | 8 mm to 28 mm   |                   |
| 1  | Adjustable wrench           | 12 in.          |                   |
| 1  | Vice grip wrench            | 12 in.          |                   |
| 2  | Chain tongs                 | 4 in cap.       |                   |
| 1  | Trowel                      | 8 in. (200 mm)  |                   |
| 1  | Heavy Hammer                | 10 lbs.         |                   |
| 1  | Light hammer                | 3 lbs.          |                   |
| 1  | Magnet                      |                 |                   |
| 1  | Pipe wrench                 | No. 813         |                   |
| 1  | Pipe wrench                 | 14 in.          |                   |
| 1  | Oiler can                   | 18 in.          |                   |
| 1  | Screen box                  | 600 x 800 mm    | Metal screen 2mm  |
| 1  | Screen box                  | 500 x 700 mm    | Metal screen 5 mm |
| 1  | Screen box                  | 600 x 800 mm    | Metal screen 1 mm |
| 1  | Small measuring cord        | 50,000 mm       |                   |
| 1  | Tube plastic joint glue     |                 |                   |
| 1  | Can thread sealing compound |                 |                   |

|      |  |                    |           |
|------|--|--------------------|-----------|
| 1    | Pipe vice                                | 3 inch cap.        |           |
| 1    | Hack saw with 3 blades                   |                    |           |
| 1    | Wood saw                                 |                    |           |
| 1    | Center punch                             |                    |           |
| 1    | Metal brush                              |                    |           |
| 4    | Steel files, flat, half round, round (2) |                    |           |
| 1    | Wood file                                |                    |           |
| 2    | Metal box with hasp                      | 400 x 300 x 650 mm | Metal     |
| 2    | Padlocks                                 |                    |           |
| 1    | Screw driver                             |                    |           |
| 1    | Phillips screw driver                    |                    |           |
| 1    | Metal hand drill                         |                    |           |
| 10   | Steel bits                               | 6 to 16 mm         |           |
| 1    | Wood brace                               |                    |           |
| 3    | Wood bits                                | 10,12, 14 mm       |           |
| 1    | Pr. tin cutters                          |                    |           |
| roll | Wire galv.                               | No. 10             |           |
| roll | Wire galv.                               | No. 15             |           |
| 1    | Cole Chisel                              | 6 in.              |           |
| 1    | Pipe threader                            | 1 to 2 in. cap.    |           |
| 1    | Rod threader                             | 10 and 12 mm cap.  |           |
| 1    | Tool box with handles                    | 300 x 500 x 80 mm  | inch wood |

**PART VII**

**SPECIAL SUBJECTS**



# 1. NIGER, REPORT ON THE INSTALLATION OF AN ABI PUMP

THE LARGE BORE WELL  
AT TENDA PLANTATION

## PCV Steve Simmons, 1974

For the past several years the Water and Forests Nursery at Tenda has experienced a water shortage near the end of the dry season. This is due to the drop in the level of the water table, lowering the ability of the large diameter well to recharge itself during the peak hours of use when thousands of trees must be watered. To correct this a Johnson 42" stainless steel drive point screen was driven into the well's sand aquifer three meters. An ABI pump was attached to this, thereby increasing the well's effective capacity. In addition, a reservoir was built to allow water to be drawn at all hours of the day and stored for use during the periods when the trees had to be watered.

The installation of the screen did not present any problem; however I did find that the threads of the screen did not match properly with those of the coupling furnished with the 2" pipe, which was bought locally. I solved this by substituting a 2" Clayton-Mark drive coupling to make the joint since it threaded onto the screen and the pipe. It was necessary to lower the screen attached to a 3 meter section of 2" pipe with the drive coupling in place and the driving hammer to the bottom of the well (24 m) and drive the screen with the short section, the hammer being operated at the surface by workers pulling on a rope passed over a pulley. I had originally intended to lower the screen into the well by means of a 2" column of pipe extending to the surface and drive from the top of the well. Due to the extreme flexibility of a 24 m column of unsupported 2" tubing, this was not possible though it might be accomplished in open wells less than 15 meters in depth.

Two steel pipe braces had previously been mounted, in concrete, on opposite sides of the well to support the two "I" beams which traversed the well on which the pump was to be mounted. Wooden decking was added although  $\frac{1}{2}$  of the well was left uncovered to allow water to be pulled by hand.

I encountered a few difficulties with the installation of the pipe and cylinder in the well. This was due to a poor connection between the 1½" drop pipe and the foot valve located immediately below the cylinder. I would offer the following suggestions to anyone using this type of apparatus in the future: Pack the joint well with angel hair and pipe sealing compound (I used dental floss and window putty). I would eliminate the 3 meter section of 1½ drop pipe which fits below the foot valve and is furnished by ABI industries, substituting a seat union. The main advantage to this would be to place the cylinder nearer to the bottom of the well where it could be serviced and examined more easily. In addition, it would facilitate joining the pipe column to the screen. Using the seat union one could avoid having to turn the entire assembly, including the pump, to make the connection. Without a union for the connection, two men must be at the bottom of the well to assure proper threading while a large number of men at the surface lift and turn the entire assembly, which requires coordination.

When measuring the well to determine the exact length of pipe needed and later when cutting and threading the pipe, one should keep in mind that pipe has a tendency to elongate during the hotter parts of the day. Thus, if one measured and cut in the afternoon and waited until the next morning to install the pipe, it might be too short to make the connection. This elongation factor can be quite critical if the well is of great depth. Once the pump is installed and the pipe connections are tight, the pipe column should appear to extend from the surface to the bottom in a straight line with very little deflexion except for that due to the peculiarities of the way one pipe joins another. This is necessary to prevent excess wear of the rod against the pipe as well as preventing excessive motion of the pipe column due to pumping.

The ABI pump comes complete with tubing and pump rod. Ordinarily this is enough for installation in a 15 meter well, although it can be ordered for other depths as well. Included in the tubing is one section of 1½ " drop pipe 3 meters long and one section of 1½" pipe which is shorter than the other pieces of 1½" pipe. There is also one section of pump rod that has a long threaded section to be used to adjust the piston stroke properly. On the pump that I installed I found that it was impossible to properly

adjust the piston without lengthening the rod, which is what I did. In addition, the pump that I received furnished no means of locking the rod to the handle lever mechanism. It necessitated cutting a section of small diameter pipe to serve as a spacer and adding two nuts, one below the point where the rod entered the handle and two above.

Upon pumping the pump, a clatter was produced whenever the handle was depressed to its lowest point. This was due to a short section of angle iron which is welded onto the handle to act as a stop striking the pump rod when the piston arrived at the top of its stroke. Cutting a slot in the stop solved the problem.

Another major problem with the ABI concerns the lower assembly, specifically the piston. The piston and footvalve are equipped with plastic valves. The valve in the footvalve is spring loaded. The valve in the piston is sometimes pushed out of its seat in the piston and becomes jammed in the open position. I have not yet arrived at a solution to this problem, although I think that putting a constrictive washer on the lower portion of the plastic valves fingers may work.

To date we have installed only one ABI pump, although we intend to install two more. In summary, on the basis of the one pump presently installed, I make the following statements:

The pump on the whole has not been entirely satisfactory. In some areas, particularly the footvalve and piston and in the manner provided for the adjustment of the piston stroke, it seems to be poorly designed. This seems to be born out by the fact that the stop that was mentioned earlier strikes the pump rod when the handle is pumped, a situation easily corrected at the factory level. The handle mechanism is seemingly strong and is mounted on sealed bearings. The upper assembly (the pump) is well made but quite heavy. The ABI is expensive, costing around \$300. This is more than other types of hand pumps even when the cost of their shipment from the States is included.



ABI PUMP - Type M - Underground Mechanism  
 POMPE ABI - Type M - Mechanism Sousterrain

BFS

Brass Cylinder  
 Cylindre en Laiton  
 90 mm  $\phi$  Exterior

Shown Cut Away  
 Eclat

PISTON ASSEMBLY  
 PISTON ASSEMBLAGE

1/2"  $\phi$  Pump Rod  
 Tringle 14mm  $\phi$

Bronze Casing  
 Chapelle Bronze

Weighted Plastic Valve  
 Clapet Plastique Leste

Leather  
 Cuir

Plastic Valve Guide  
 Guide Plastique

Plastic Valve in  
Bronze Casing  
 Clapet Plastique en  
 Chapelle Bronze

1 1/2"  $\phi$  Galvanized  
Suction Pipe  
 Tuyau Aspirant  
 Galvanise 33/42

Plastic Foot Valve  
in Bronze Casing  
 Clapet en Plastique  
 en Chapelle Bronze

Plastic Screen Containing  
480 Holes of 3mm  $\phi$   
 Crepine Plastique avec  
 480 Trous de 3mm  $\phi$

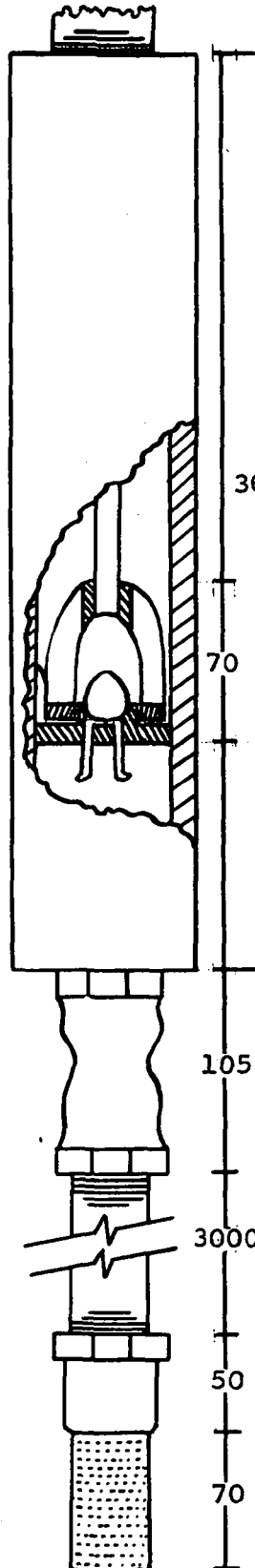

Steel Connector  
 Manchon en Acier

Nut  
 Ecrou

Rubber Guide  
 Guide Caoutchou

1/2"  $\phi$  Pump Rod  
 Tringle 14mm  $\phi$

1 1/2"  $\phi$  Lift Pipe  
 Galvanized

Tuyau Refoulement  
 Galvanise 40/49

Brass Cylinder  
 Cylindre Laiton  
 90mm  $\phi$  Exterior

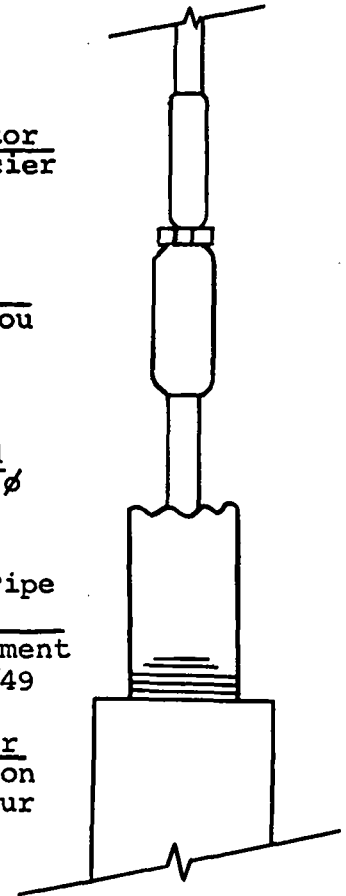

$\phi$  = Diameter  
 Diametre

The Lift Pump and Pump Rod are  
 Furnished in 3 Meter Lengths  
 Les Tuyaux Refoulement et  
 Tringles sont Fournis en Longeurs  
 de 3 Metres

ABI PUMP - Type M - Surface Mechanism  
 POMPE ABI- Type M - Mechanism Surface

BFS

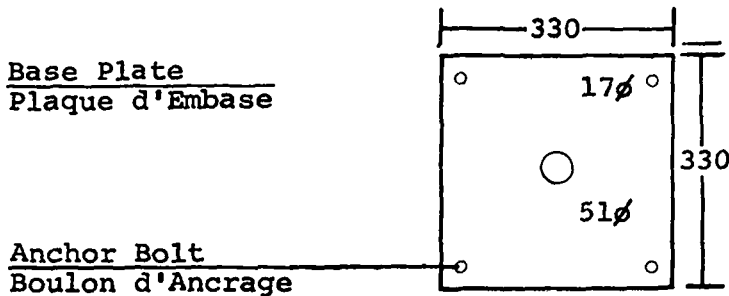
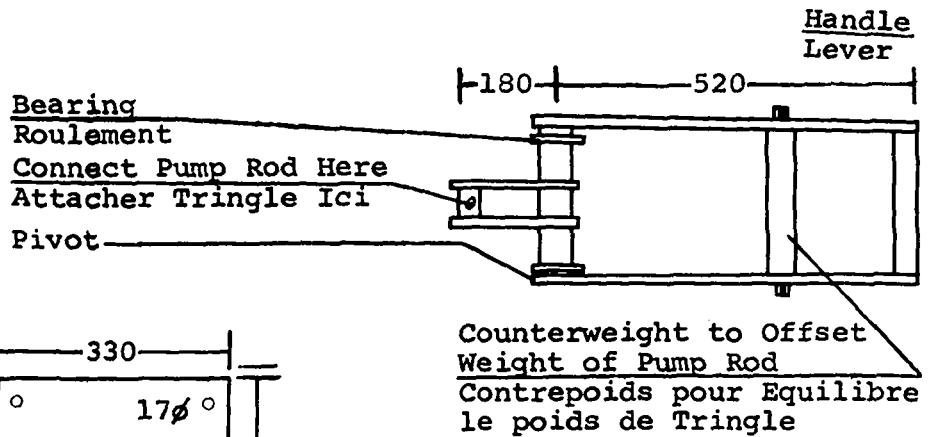
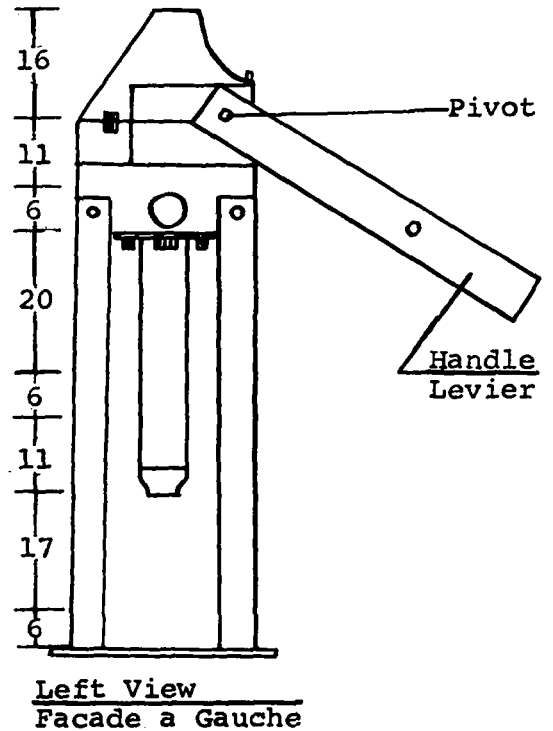
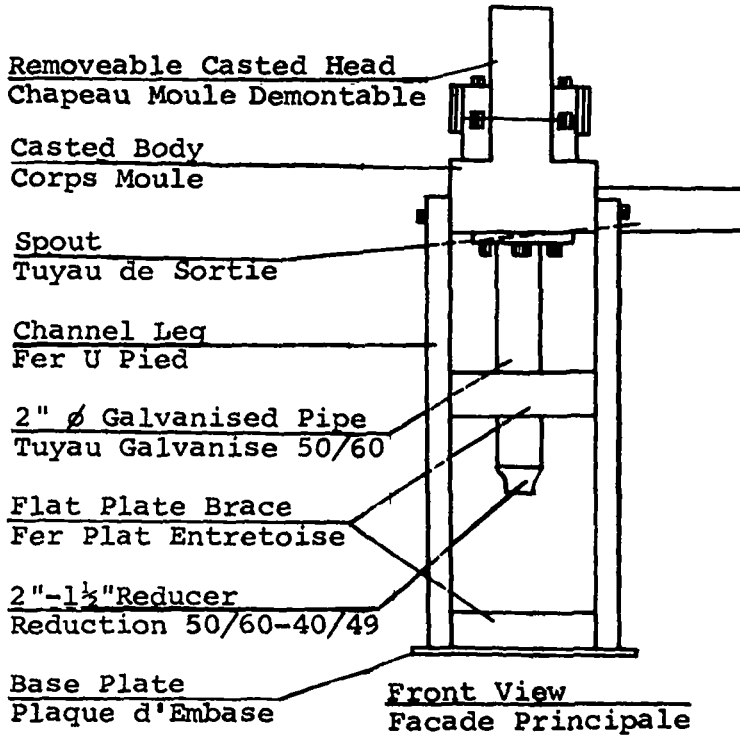

$\phi$  = Diameter  
 Diametre

N.B. All joints are welded unless otherwise indicated.  
 Si ce n'est pas autrement indique tout les joints sont soudés.

# 2. NIGER, SMALL BORE WELLS FOR SCHOOL GARDENS MARDI PCV Lee Yellott 1974

## CRITERIA FOR DIGGING WELLS

The locations where the wells are dug are a function of the schools in the project. The project is controlled by an inter-service commission of eight members. Final selection of schools to be included in the project is made by this commission. Locations are generally dependant upon the water source conditions. Practical limitations of well-digging operations are: (1) no wells should be dug where water is found deeper than 30 meters, due to the limitation of the project's hand-operated drilling rig, and (2) due to the poor quality of the rig, penetration through thick layers of rock or hard pan is difficult. Although wells have been bored in such areas, the time, effort, and damage to the equipment makes such attempts costly. With better designed and sturdier equipment this limitation could be overcome.

## PROCEDURES

Once the site has been decided on, the tripod is erected over the chosen place for the well. Loose sand is cleared away from the area and the hole is started with a post-hole digger to a depth of about one meter.

Planks are then arranged to form a guide for the drill stem and also to form a platform around the hole. The upper guide is formed by two planks set into the ground about  $\frac{1}{2}$  meter and at two meters apart. A third plank is laid across the two uprights about  $1\frac{1}{2}$  meters above the ground. A slot in the upper plank and a rope to hold the pipe in the slot form the guide.

The guide and platform in place, a spiral auger (140 mm) is connected to a 3 meter section of drill stem. A sliding handle is then attached to this section of drill stem. Two to four men turn the auger until it fills with soil. The auger is pulled out by hand, emptied, and replaced for continued digging. The spiral auger is the main digging tool, but other augers are used

depending on the situation. In the event of hard digging, augers can continue to be used. The bit is 6 meters long, and it consists of a section of 3 inch pipe to which a cutting edge (a leaf spring from a large truck) has been attached.

Usually no cave-in conditions are encountered until the water table is reached. At the water table, cave-ins are a problem, and casing must be installed to continue digging. Plastic casing (110-100mm) is prepared by drilling thousands of 1.5 mm holes along a 2-3 meter section of the first pipe to be lowered into the bore hole. Other sections of plastic pipe are added until the screen rests on the bottom of the hole.

The screen is then bailed into the water table by using a 80mm bailing bucket which pulls out the sand slurry and at the same time applies a downward pressure on the casing. If the casing becomes lodged and does not descend on bailing, smaller augering tools (80mm) are used to free the casing. All attempts are made to install the screen at least four meters into the water table to assure a sufficient, all-year flow of water.

Once the casing is in place, the well is developed by using a solid plunger (100mm in diameter). The plunger is lowered to the water level and worked up and down to wash the fine sand into the well. The well is then bailed and cleaned. As a result, only the larger gravel rests up against the screen, and a good flow of water is assured.

The final operation consists of cementing a ring around the casing that extends 25 cm above the ground.

#### WATER LIFTING DEVICES

Water from small bore wells in this project is pulled up by means of a bailing bucket similar to that described above in the digging operations. They are made of aluminum pipe (80mm x 1½ m) with a foot valve and a hook for attaching a rope.

Rather than pulling the buckets by hand, which causes considerable wear to the ropes on the side of the well, a crank system is installed over the well. This year, some experimentation has begun into the use of hand pumps.

In an attempt to cut costs for the pumping devices, as many local materials as possible are used. The parts are ordered from the U.S. when necessary. These include cylinders, pistons, foot valves, and rod couplings. Pump rods (12mm reinforcing rod) and handles (wooden) are made locally.

For designs of the various tools and equipment described in this report, the reader is referred to the Village Technology Handbook (AID) for the following items:

Pump handle (p.13), drill stem connections (p. 32, 43), auger (p. 33), drill stem guide (p. 51), handle (p.44), bailing bucket (p.63). For the surge plunger, see Small Wells Manual, (Gibson & Singer), p.99.

# 3. DEVELOPMENT OF HAND OPERATED WATER PUMP

R.D. Fannon, Jr., Battelle Columbus  
1974

## INTRODUCTION

A great number of requests have been received for information regarding the AID-Battelle program to develop an improved hand pump for rural domestic water supplies. Special funds have recently been appropriated to compile the results from this work to date and make it available.

## BRIEF HISTORY OF EXPERIENCE

Early in 1966, the Agency for International Development (AID) and the Battelle Columbus Laboratories (BCL) discussed the increasing need for rural water supply systems for developing nations. It was decided during these meetings and subsequently substantiated that successful domestic water programs must be carried out within the country for which they are intended. Such programs not only provide a more reliable water system but also stimulate industry and business within the country.

The most basic need apparent was for a dependable hand pump. Basic specifications for such a pump were established early in the program and without exception they still prevail. These specifications are

- (1) Low production costs
- (2) Long life under severe conditions
- (3) Easy to maintain with simple tools and unskilled labor
- (4) Suitable for shallow or deep well installations with only minor changes (cylinder location)
- (5) Capable of being manufactured by established firms within the developing countries and/or with a minimum of capital investment

- (6) Easily operated by small people, including women and children
- (7) Includes design features which will discourage pilfering and vandalism.

A shallow well pump is defined here as a pump in which the cylinder is attached to the pump body above the ground. A deep well pump is defined as a pump in which the cylinder is separated from the pump body and submerged below the level of the water being pumped.

In addition to these specification, it might also be appropriate to note here that any rural domestic water program of any size must contain the following:

- (1) Funds must be available by which pumps can be made and wells sunk and/or means by which pumps and their installation can be purchased by consumers.
- (2) Facilities must be available or provided in which pumps and associated products can be fabricated.
- (3) Governmental organizations or private sales organizations must be available for pump distribution and installation. This would also include well drilling.
- (4) Means must also be made available for spare parts distribution and pump maintenance.
- (5) Effectiveness of any program depends upon good coordination with the local people in regard to operations and pump configuration. Each area can be different depending upon the local conditions, customs, and aesthetic values.

The program to develop an improved domestic water pump was conducted by Battelle for AID in three steps.

- (1) Examination of existing conditions
- (2) Pump development and laboratory evaluation
- (3) Field evaluation programs

Although steps 1 and 2 have been completed, some development in terms of improvements is still going on.

In the many visits to various developing countries the following conditions and practices are found to exist:

- (1) Lack of pumps and facilities to make them
- (2) Some areas had pumps given them, but many different kinds with little or no maintenance and with improper parts
- (3) Lack of community spirit toward community water supply systems even to the extent of vandalism
- (4) The reluctance of government officials to act as positively or as effectively as they could
- (5) Inadequate pump design, both those made in the country and those being imported. The inadequacies may be described as follows:
  - (a) Cylinders too rough
  - (b) Plunger cups improperly sized (generally too large)
  - (c) Highly stressed fulcrums and handles
  - (d) Bearing surfaces too small
  - (e) Valve seats poorly cast and machined
  - (f) Fasteners (bolts and nuts) poorly made.
- (6) Inadequate storage facilities--many of the parts are so deteriorated that they cannot be used.
- (7) In many areas hand operated water pumps are in such demand that even so-called good pumps will not stand up under such rigorous usage. Good maintenance programs are required under all conditions.

A deep well and shallow well pump configuration was developed incorporating improvements for many of the deficiencies noted. Sample pumps were tested in the laboratory and currently a field evaluation program is being conducted in three areas: Bangladesh (in cooperation with UNICEF), Nigeria (under direction of CARE), and Thailand (under direction of AID). The actual pump configurations vary some from one country to another, as should, but the major design points remain the same. The pump configuration to be described reflects the latest field findings.



## PUMP DESCRIPTION

Figures 1 and 2 are assembly drawings of the shallow and deep well pumps, respectively. A parts list follows the drawings for convenient part identification. It can be seen that there is little difference in the pumps except for the cap and fulcrum. It might be noted that the deep well configuration could well be used on both deep and shallow wells; however, the initial cost would be slightly higher than necessary for the shallow wells.

### General Description

Except for the steel pipe and a few other parts, the pump is gray cast iron with a composition as close as possible to that shown in Table 1.

TABLE 1. RECOMMENDED SPECIFICATIONS FOR FOUNDRY PIG IRON

| Silicon     | Carbon      | Manganese   | Sulfur   | Phosphorus  |
|-------------|-------------|-------------|----------|-------------|
| 2.50 - 2.75 | 4.10 - 3.85 | 0.50 - 1.25 | 0.05 max | 0.30 - 0.50 |
| 2.76 - 3.00 | 4.05 - 3.70 | 0.50 - 1.25 | 0.05 max | 0.30 - 0.50 |
| 3.01 - 3.25 | 3.90 - 3.65 | 0.50 - 1.25 | 0.05 max | 0.30 - 0.50 |
| 3.26 - 3.50 | 3.85 - 3.60 | 0.50 - 1.25 | 0.05 max | 0.30 - 0.50 |

The carbon ranges listed are to be used only as an indication of the desired carbon content of the pig iron. It is very difficult, if not impossible, to make foundry pig iron to specified silicon and carbon contents. However, the carbon content and silicon content should be in balance in order to produce gray cast iron castings with less variations in composition. The silicon content should and can be supplied to the designated ranges, and the carbon content should be reasonably close to the values indicated. As an example, the silicon content may be specified as 2.76 to 3.25 percent - the corresponding carbon content should be in

the range of 4.05 to 3.65 percent. The carbon contents are shown in a reverse order intentionally because as the silicon content increases in pig iron, the carbon content will decrease.

Coke specifications are also necessary to produce a satisfactory product. Table 2 indicates minimum standards.

TABLE 2. RECOMMENDED SPECIFICATION FOR FOUNDRY COKE (WEIGHT PERCENT)

| <u>Fixed<br/>Carbon</u> | <u>Volatile<br/>Matter</u> | <u>Ash<br/>Content</u> | <u>Sulfur<br/>Content</u> |
|-------------------------|----------------------------|------------------------|---------------------------|
| 88.0 min                | 1.0 max                    | 12.0 max               | 1.0 max                   |

The values specified are to be used as a guide when purchasing foundry coke; however, every effort should be made to obtain foundry cokes that have a minimum ash content. An 8.0 to 10.0 percent ash content is very desirable. Sulfur content should also be as low as possible. The higher the sulfur content in the coke, the higher will be the sulfur content of the gray cast iron produced, and the greater possibility for metal problems caused by excess sulfur.

#### General Construction Details

The sample shallow well pump cap provides a strong fulcrum for heavy use and the deep well cap provides firm wear resistant surfaces.

The pump has a 7-1/2 inch to 8-inch stroke which is quite important when the water table is low, and a 6 to 1 ratio handle to help ease pumping. The center section is made of steel pipe and within limits can be made various lengths increasing or decreasing pump height. Jam nuts are used at all pump rod connections to help prevent rod separations. The pump base is sized to fit over 6-inch well casing and will accept 1-1/4" to 1-1/2" drop pipe. General construction is such as to stand up under heavy use and yet be as light as possible.

## Cylinder Construction

Laboratory tests and field evaluation indicate the secret of long cup life is the smoothness of the cylinder in which the plunger operates. An extruded brass cylinder has a smoothness of 8 to 12 micro inch (CLA)\*. In contrast, some of the machined iron cylinders taken out of storage were so rough (over 600) due to rust and poor castings that measurements were hard to make. Better castings with more careful machining measured between 200 and 300 micro inch (CLA).

To obtain a very smooth finish, coated cylinders were developed. Two types of coated cylinders have been tested in the laboratory. One coating consists of an epoxy-phenolic resin requiring a low-temperature bake as part of the curing process. This coating is the toughest and most wear-resistant of the two coatings with a smoothness of 12 to 18 micro inch (CLA). This coating performed well in limited field use and would be preferred if baking facilities can be made available. The second coating is an air cure epoxy coating which is not quite as tough and takes longer to cure than the baked coating. This has a smoothness of about 40 micro inch (CLA). This coating has no field evaluation to date. Both types of coated cylinders can be used for shallow well and deep well pumps and are quite inexpensive to apply.

As an alternative, plastic pipe may be used for cylinder construction. Polyvinyl chloride (PVC) plastic pipe is as smooth as extruded brass, costs much less than brass, and field tests have shown it to wear as well. It is recommended for deep well applications. Although the PVC pipe cylinder is more expensive than a coated cylinder, the ease of manufacture (a simple cut-off operation) makes its use for sleeves in shallow well pumps very attractive.

---

\* Center line average

## Cups and Valves

Good quality leather is recommended for making plunger cups. Dyes should not be used; however, wax impregnant is acceptable. No special treatment has yet been identified; however, a particular tanning or special treatment may be indicated by current testing. Cups should not fit tight in the cylinders, but instead depend upon the water pressure or suction to seal the cup against the cylinder walls.

Two types of valves are currently in use, poppet and flapper. There is much discussion about which type is best, and no firm answer is available. However, both types depend upon a generous, smooth, well-machined seat. Poppet valves are cast iron or brass which is preferred and leather or rubber washers can be used to help improve the seal. Leather is still the standard material for flapper valves with a cast iron weight. Plastics and composite materials such as nylon impregnated with neoprene should also be considered.

## Bearings

The pinned joints should be no less than 5/8-inch diameter and the length such as to insure a projected bearing area of at least 0.94 square inch. If hard use of the pump is to be expected, even larger pins are recommended. Lubrication where possible almost always improves wear. Generally speaking, most shops in developing areas cannot afford the cost of special bearings, nor are they capable of properly fitting bearings, but hardening the cast iron bearing (hole) can be done and is recommended to greatly improve bearing life at a minimum cost.

## Pump Options

The pump shown as Option A utilizing a bolt-on cover with fulcrum and a screwed-on center section and base is recommended; however, circumstances may require other configurations. Option B utilizes pinned-on covers

and fulcrums for areas where bolts and nuts are of poor quality, nonexistent, or where vandalism or stealing is a problem. For tube wells, the base can be omitted and the bottom cap with valve of the deep well cylinder can be substituted making up Option C. Option D is where the pump body and cylinder (shallow well pump) are cast as one piece and a PVC liner is inserted to provide a smooth bore. Other variations are available to match facilities and skills available and type of consumer operation, but simplicity is the key to the most reliable and inexpensive configuration. However, care must be taken not to compromise pump operations.

#### CURRENT EVALUATION

The shallow well pump as fabricated under several options has been proven to stand up well. The plastic deep well cylinder is also being used quite extensively; however, the deep well pump cap is a relatively new arrangement and more data are needed before its capability of withstanding hard use can be confirmed.

Data on valves are conflicting in that both the poppet and flapper types are preferred in different areas. It has been noted, however, that poorly prepared sealings surfaces are not acceptable under any conditions.

#### PUMP DESIGN PRINCIPLES

The fabricator, installer, and user should be aware of certain design limitations. First, it is recommended that no cylinder sizes over 3-inches diameter be used. It has been observed that leather cups tend to fail rather than wear out in 3-1/2-inch shallow well pumps. It is our feeling that the strength of the cup is not sufficient to withstand the pressure or vacuum created by the pump action and buckling occurs during one portion of the stroke (stretching during the opposite portion of the stroke) causing the cup material to split circumferentially and fail.

Neglecting friction or insufficient flow passageway which can create a substantial load, 3-inch cylinders will require 3.06 pounds lifting force per foot of water being lifted. This means, for example, that for a shallow well with a 26 foot deep water level, about 79.5 (26 x 3.06) pounds of lifting force will be required. This is about the maximum lift for a shallow well pump, and for the pump illustrated approximately 14 pounds ( $\frac{79.6 \times 5}{28.5}$ ) of force is needed at the end of the handle for operation.

In contrast, a deep well pump must operate under much more severe conditions. Again, for the deep well pump illustrated, a 100-foot water lift would require about 357 (100 x 3.06 + 51.1) pounds of force (including the weight of 7/16 diameter pump rod but neglecting friction) and a handle force of over 62.5 ( $\frac{357 \times 5}{28.5}$ ) pounds. Such an arrangement can be improved one of two ways: Make the handle longer or decrease the cylinder size. Most persons can see that increasing the handle length or lever arm decreases the force required for operation, but it may not be apparent in the case with the change in cylinder size. A 2-1/2-inch diameter plunger requires about 2.12 pounds per foot of water lift for operation and for a 100-foot water lift including the weight of the rod but neglecting friction, 263 (2.12 x 100 + 51.1) pounds of force would be required. The handle force would be 46.2 ( $\frac{263.1 \times 5}{28.5}$ ) pounds, over 25 percent reduction from the handle force required by the 3-inch cylinder. A 25 percent increase in handle length decreases the handle force about 20 percent to 50.13 pounds. Every effort should be made to keep the handle force below 40 pounds to permit operation by women and children. Table 3 summarizes the forces discussed.

Decreasing the bearing loading is another factor for reducing cylinder size. Loading is not appreciably affected by a change in handle length. 300 psi is a maximum bearing load for mild steel pins and cast iron journals when lubricated and with a close "running" fit. Since most pumps operate with moving joints of a very sloppy fit, the bearing levels should be kept as low as possible for long life--perhaps below 100 psi if possible. The pumps currently under evaluation have bearings from 5/8-inch diameter to 3/4-inch diameter and at least 1-1/2-inch total length each

TABLE 3. SUMMARY OF PLUNGER LOADS AND HANDLE FORCES FOR VARIOUS PUMP/WELL CONDITIONS

| Effective Handle Length, in. | Cylinder Size, in. | Water Depth, ft | Plunger Load, lbs | Handle Force, lbs |
|------------------------------|--------------------|-----------------|-------------------|-------------------|
| 28.5                         | 3                  | 26              | 79.5              | 14                |
| 28.5                         | 3                  | 100             | 357               | 62.5              |
| 28.5                         | 2.5                | 100             | 263               | 46                |
| 35.6                         | 3                  | 100             | 357               | 50.1              |
| 35.6                         | 2.5                | 100             | 263               | 36.9              |

joint. Wear, although much improved, can still be a problem. To sum up these points, cylinder diameter, bearing area of each joint, and handle length must be seriously considered and balanced out to provide long life and easy operation.

One last comment on this topic; the greater the lift of water the greater pressure and increase of wear of the plunger cap. Therefore, as wear becomes excessive due to depth, the number of cups should be increased. Trial operation should soon determine when a second or third cup would be required. It has been suggested by one pump manufacturer that water levels at the 50- and 125-foot depths would be levels at which cups would be added for 3-inch cylinders. As pressures become too great, cylinder size would have to be reduced to increase the cup life.

#### ADDITIONAL REFINEMENTS

Four areas of further improvement to increase pump longevity are (1) Bearings, (2) Cups, (3) Valves, and (4) Piping. Bearing life, and consequently pump life with reduced maintenance, can be improved by the use of lubricated or nonlubricated ball bearings or bushings. The type chosen really depends upon the sophistication in machining the fabricator has available and the money available to buy and/or make the pumps. In most developing areas encountered to date, the degree of capability and money does not appear available; however, an improvement can be made that does seem within reason in many areas. The cast iron journals or "holes" should be hardened by heating to a cherry red and quenching in water. Almost any degree of hardness will improve the bearing life. Care must be taken, however, to guard against tempering one hole while hardening another.

New materials for fabricating plunger cups may soon be available including the reappearance of "Corfam", once manufactured by DuPont. For materials to be useful in cup fabrication, they must be leather-like in ability to expand against the cylinder wall proportionately to the pressure developed by the depth of water being pumped. Qualities to look for are



improved storage life, resistance to fungus, etc, improved abrasion resistance, and ability to withstand wet and dry cycling.

New materials available for plunger cups might also be considered for valves; here, the ability to expand is not required.

Plastic pipe for use as drop pipe should also be considered for cost-saving installations. Not only may plastic pipe be less expensive to buy, but lighter than steel pipe and cheaper to ship. Although plastic material has lower mechanical strength than steel, is more sensitive to temperature variation, and requires more careful handling, it is not as subject to corrosion as steel, has a lower friction factor, and can be easily jointed in the field. Care must be taken, however, to assure that no bending loads are placed on the pipe and that steel pipe be used for top sections and for securing the pump. Plastic screens are also being installed in some areas.

#### ADDITIONAL INFORMATION

It is hoped that the information included in this report is of some value to you. Additional data (Battelle's final report on Contract No. AID/csd-3305) will be available by Spring, 1975, and can be obtained through AID. If you are serious about pump production in your area or improving rural domestic water programs and additional information would be of help, please contact Mr. A. Dale Swisher of AID or Mr. Robert D. Fannon of Battelle at the addresses below. We also encourage you to participate with us in this program; and if you desire to do so, we invite you to contact us by writing to the addresses below.

Robert D. Fannon, Jr., P.E.  
Research Engineer  
Battelle  
Columbus Laboratories  
505 King Avenue  
Columbus, Ohio 43201  
USA

A. Dale Swisher, P.E.  
Office of Health  
Technical Assistance Bureau  
Agency for International Development  
Washington, D.C. 20523  
USA

239

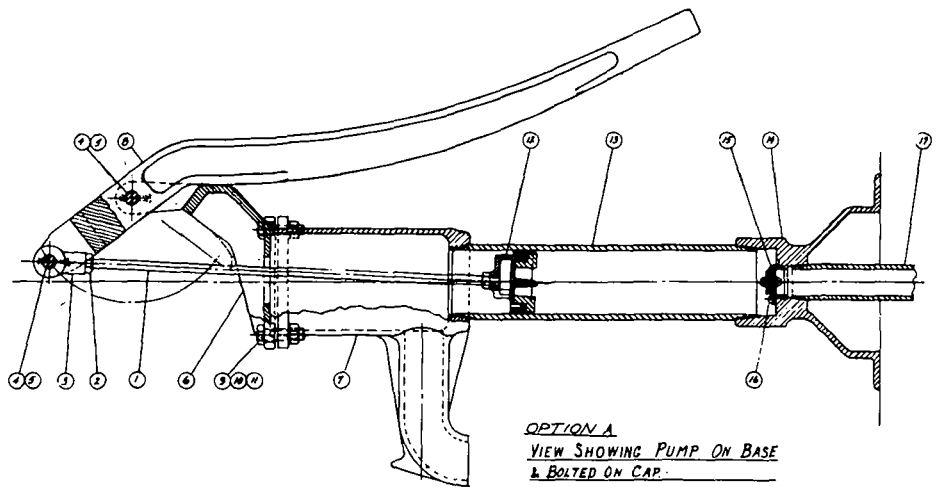
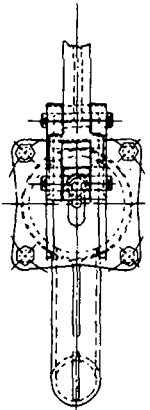
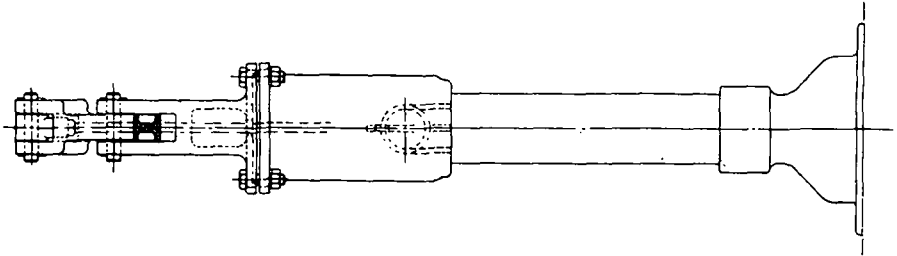

**OPTION A**  
VIEW SHOWING PUMP ON BASE  
& BOLTED ON CAP.

| REVISIONS |      |             |    |
|-----------|------|-------------|----|
| NO.       | DATE | DESCRIPTION | BY |
|           |      |             |    |

| QTY | DESCRIPTION               | SPECIFICATION                   |                  |
|-----|---------------------------|---------------------------------|------------------|
| 17  | STEEL PIPE                | 1/2" DIA                        |                  |
| 16  | HANDLING SCREW ROD, BRASS | 3/8" DIA, 1/2" L                |                  |
| 15  | 2014                      | B CHECK VALVE ASSEMBLY          |                  |
| 14  | 2014                      | D PUMP STAND ASSEMBLY           |                  |
| 13  | 2014                      | D PUMP CYLINDER ASSEMBLY        |                  |
| 12  | 1                         | B PLUMBER ASSEMBLY - SINGLE COP |                  |
| 11  | 4                         | LOCK WASHER                     | 1/2" DIA, HEAVY  |
| 10  | 4                         | NUT (HEAVY)                     | 1/2" DIA, HEAVY  |
| 9   | 4                         | BOLT - HEX HD                   | 1/2" DIA         |
| 8   | 1                         | HANDLE                          | CAST IRON        |
| 7   | 1                         | PUMP BODY                       | CAST IRON        |
| 6   | 1                         | PUMP CAP                        | CAST IRON        |
| 5   | 4                         | COTTER PIN (1/16" DIA)          | 1/16" DIA        |
| 4   | 2                         | 2007                            | A PISTON PIN     |
| 3   | 1                         | 2004                            | B ROD END        |
| 2   | 1                         | 2005                            | A PUMP ROD END   |
| 1   | 1                         | 2003                            | A CAST PUMP BODY |

NOTE:  
ASSEMBLY OF PUMP BODY, PIPE & PUMP STAND MUST BE TIGHT WITH AT LEAST 1/2" THREAD ENGAGEMENT AT EACH JOINT.

**OPTION C**  
VIEW SHOWING LOWER VALVE HOUSING  
MOUNT DIRECTLY TO WELL PIPE.

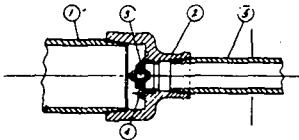

NOTE:  
ALL PARTS ABOVE PUMP CYLINDER ARE IDENTICAL TO THOSE SHOWN IN VIEW OF PUMP SHOWN ABOVE.

| QTY | DESCRIPTION               | SPECIFICATION                  |
|-----|---------------------------|--------------------------------|
| 3   | STEEL PIPE                | 1/2" DIA                       |
| 4   | HANDLING SCREW ROD, BRASS | 3/8" DIA, 1/2" L               |
| 1   | 2014                      | B CHECK VALVE ASSEMBLY         |
| 1   | 2014                      | C LOWER VALVE HOUSING ASSEMBLY |
| 1   | 2014                      | D PUMP CYLINDER ASSEMBLY       |

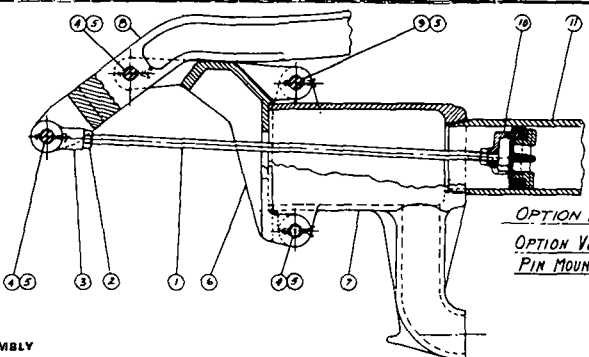
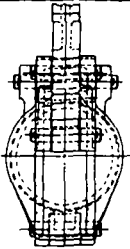

**OPTION B**  
OPTION VIEW OF PUMP WITH  
PIN MOUNTED CAP.

NOTE:  
ALL PARTS ABOVE PUMP CYLINDER ARE IDENTICAL TO THOSE SHOWN IN EITHER OF THE VIEWS SHOWN ABOVE.

| QTY | DESCRIPTION | SPECIFICATION                   |                          |
|-----|-------------|---------------------------------|--------------------------|
| 11  | 2014        | D PUMP CYLINDER ASSEMBLY        |                          |
| 10  | 2009        | B PLUMBER ASSEMBLY - SINGLE COP |                          |
| 9   | 2014        | A CAST PIPE                     |                          |
| 8   | 1           | HANDLE                          | CAST IRON                |
| 7   | 1           | 2014                            | D PUMP BODY              |
| 6   | 1           | 2011                            | D PUMP CAP               |
| 5   | 4           | 2005                            | A COTTER PIN (1/16" DIA) |
| 4   | 2           | 2004                            | B ROD END                |
| 3   | 1           | 2003                            | A CAST PUMP BODY         |
| 2   | 1           | 2005                            | A PUMP ROD END           |
| 1   | 1           | 2003                            | A CAST PUMP BODY         |

FIGURE 1. SHALLOW WELL PUMP ASSEMBLY

|  |   |  |  |
|--|---|--|--|
| <p>APPLICATION</p> <p>DATE</p> <p>DESIGNED BY</p> <p>CHECKED BY</p> <p>APPROVED BY</p> | <p>DO NOT SCALE DRAWING</p> <p>ALL DIMENSIONS IN INCHES UNLESS OTHERWISE SPECIFIED</p> <p>FINISHES: UNLESS OTHERWISE SPECIFIED</p> <p>CAST IRON: UNLESS OTHERWISE SPECIFIED</p> | <p>REV. NO.</p> <p>DATE</p> <p>DESCRIPTION</p> | <p>DATE</p> <p>BY</p> <p>DESCRIPTION</p> |
| <p><b>Bolted</b></p> <p><b>HAND PUMP ASSEMBLY</b></p> <p><b>SHALLOW WELL TYPE</b></p>  |   |  |  |
| <p>E 79986 606 (2948-0001-2001)</p>  |   |  |  |

240

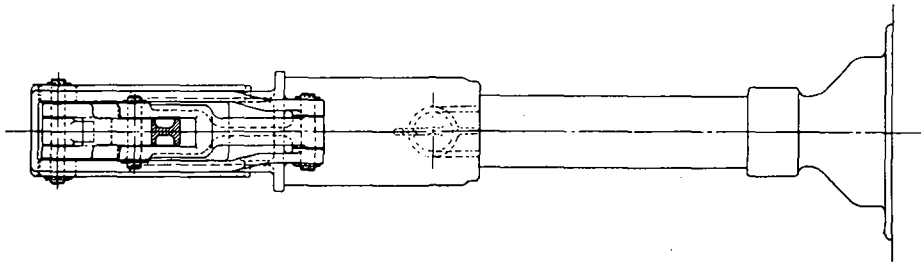

| REVISIONS |      |             |    |
|-----------|------|-------------|----|
| NO.       | DATE | DESCRIPTION | BY |
| 1         |      |             |    |
| 2         |      |             |    |
| 3         |      |             |    |
| 4         |      |             |    |
| 5         |      |             |    |
| 6         |      |             |    |
| 7         |      |             |    |
| 8         |      |             |    |
| 9         |      |             |    |
| 10        |      |             |    |
| 11        |      |             |    |
| 12        |      |             |    |
| 13        |      |             |    |
| 14        |      |             |    |
| 15        |      |             |    |
| 16        |      |             |    |
| 17        |      |             |    |
| 18        |      |             |    |
| 19        |      |             |    |
| 20        |      |             |    |
| 21        |      |             |    |
| 22        |      |             |    |
| 23        |      |             |    |
| 24        |      |             |    |
| 25        |      |             |    |
| 26        |      |             |    |
| 27        |      |             |    |
| 28        |      |             |    |
| 29        |      |             |    |
| 30        |      |             |    |
| 31        |      |             |    |
| 32        |      |             |    |
| 33        |      |             |    |
| 34        |      |             |    |
| 35        |      |             |    |
| 36        |      |             |    |
| 37        |      |             |    |
| 38        |      |             |    |
| 39        |      |             |    |
| 40        |      |             |    |
| 41        |      |             |    |
| 42        |      |             |    |
| 43        |      |             |    |
| 44        |      |             |    |
| 45        |      |             |    |
| 46        |      |             |    |
| 47        |      |             |    |
| 48        |      |             |    |
| 49        |      |             |    |
| 50        |      |             |    |
| 51        |      |             |    |
| 52        |      |             |    |
| 53        |      |             |    |
| 54        |      |             |    |
| 55        |      |             |    |
| 56        |      |             |    |
| 57        |      |             |    |
| 58        |      |             |    |
| 59        |      |             |    |
| 60        |      |             |    |
| 61        |      |             |    |
| 62        |      |             |    |
| 63        |      |             |    |
| 64        |      |             |    |
| 65        |      |             |    |
| 66        |      |             |    |
| 67        |      |             |    |
| 68        |      |             |    |
| 69        |      |             |    |
| 70        |      |             |    |
| 71        |      |             |    |
| 72        |      |             |    |
| 73        |      |             |    |
| 74        |      |             |    |
| 75        |      |             |    |
| 76        |      |             |    |
| 77        |      |             |    |
| 78        |      |             |    |
| 79        |      |             |    |
| 80        |      |             |    |
| 81        |      |             |    |
| 82        |      |             |    |
| 83        |      |             |    |
| 84        |      |             |    |
| 85        |      |             |    |
| 86        |      |             |    |
| 87        |      |             |    |
| 88        |      |             |    |
| 89        |      |             |    |
| 90        |      |             |    |
| 91        |      |             |    |
| 92        |      |             |    |
| 93        |      |             |    |
| 94        |      |             |    |
| 95        |      |             |    |
| 96        |      |             |    |
| 97        |      |             |    |
| 98        |      |             |    |
| 99        |      |             |    |
| 100       |      |             |    |

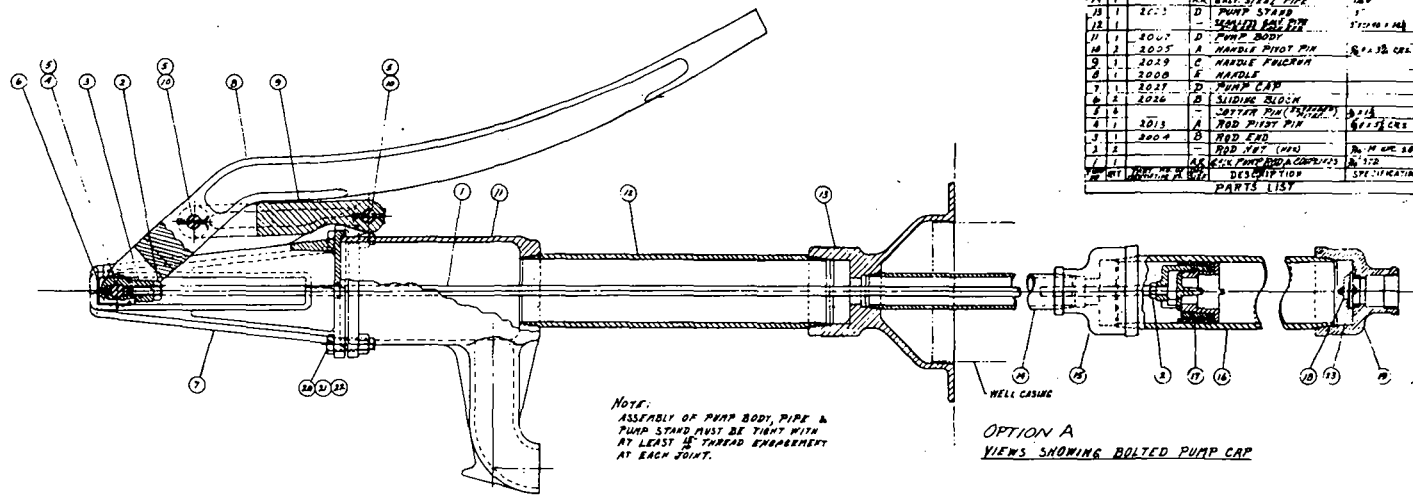
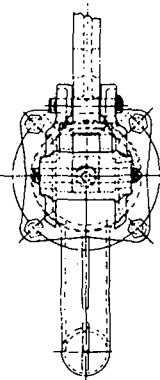

NOTE:  
ASSEMBLY OF PUMP BODY PIPE &  
PUMP STAND MUST BE TIGHT WITH  
AT LEAST 1/2" THREAD ENGAGEMENT  
AT EACH JOINT.

OPTION A  
VIEWS SHOWING BOLTED PUMP CAP

| NO. | QTY. | DESCRIPTION | UNIT        | REMARKS |
|-----|------|-------------|-------------|---------|
| 13  | 2    | WASHER      | 1/2" X 1/4" |         |
| 14  | 4    | LOCK WASHER | 1/2" X 1/4" |         |
| 15  | 4    | NUT (STD)   | 1/2" X 1/4" |         |
| 16  | 4    | BOLT (STD)  | 1/2" X 1/4" |         |
| 17  | 1    | 2016        |             |         |
| 18  | 1    | 2015        |             |         |
| 19  | 1    | 2014        |             |         |
| 20  | 1    | 2013        |             |         |
| 21  | 1    | 2012        |             |         |
| 22  | 1    | 2011        |             |         |
| 23  | 1    | 2010        |             |         |
| 24  | 1    | 2009        |             |         |
| 25  | 1    | 2008        |             |         |
| 26  | 1    | 2007        |             |         |
| 27  | 1    | 2006        |             |         |
| 28  | 1    | 2005        |             |         |
| 29  | 1    | 2004        |             |         |
| 30  | 1    | 2003        |             |         |
| 31  | 1    | 2002        |             |         |
| 32  | 1    | 2001        |             |         |
| 33  | 1    | 2000        |             |         |
| 34  | 1    | 1999        |             |         |
| 35  | 1    | 1998        |             |         |
| 36  | 1    | 1997        |             |         |
| 37  | 1    | 1996        |             |         |
| 38  | 1    | 1995        |             |         |
| 39  | 1    | 1994        |             |         |
| 40  | 1    | 1993        |             |         |
| 41  | 1    | 1992        |             |         |
| 42  | 1    | 1991        |             |         |
| 43  | 1    | 1990        |             |         |
| 44  | 1    | 1989        |             |         |
| 45  | 1    | 1988        |             |         |
| 46  | 1    | 1987        |             |         |
| 47  | 1    | 1986        |             |         |
| 48  | 1    | 1985        |             |         |
| 49  | 1    | 1984        |             |         |
| 50  | 1    | 1983        |             |         |
| 51  | 1    | 1982        |             |         |
| 52  | 1    | 1981        |             |         |
| 53  | 1    | 1980        |             |         |
| 54  | 1    | 1979        |             |         |
| 55  | 1    | 1978        |             |         |
| 56  | 1    | 1977        |             |         |
| 57  | 1    | 1976        |             |         |
| 58  | 1    | 1975        |             |         |
| 59  | 1    | 1974        |             |         |
| 60  | 1    | 1973        |             |         |
| 61  | 1    | 1972        |             |         |
| 62  | 1    | 1971        |             |         |
| 63  | 1    | 1970        |             |         |
| 64  | 1    | 1969        |             |         |
| 65  | 1    | 1968        |             |         |
| 66  | 1    | 1967        |             |         |
| 67  | 1    | 1966        |             |         |
| 68  | 1    | 1965        |             |         |
| 69  | 1    | 1964        |             |         |
| 70  | 1    | 1963        |             |         |
| 71  | 1    | 1962        |             |         |
| 72  | 1    | 1961        |             |         |
| 73  | 1    | 1960        |             |         |
| 74  | 1    | 1959        |             |         |
| 75  | 1    | 1958        |             |         |
| 76  | 1    | 1957        |             |         |
| 77  | 1    | 1956        |             |         |
| 78  | 1    | 1955        |             |         |
| 79  | 1    | 1954        |             |         |
| 80  | 1    | 1953        |             |         |
| 81  | 1    | 1952        |             |         |
| 82  | 1    | 1951        |             |         |
| 83  | 1    | 1950        |             |         |
| 84  | 1    | 1949        |             |         |
| 85  | 1    | 1948        |             |         |
| 86  | 1    | 1947        |             |         |
| 87  | 1    | 1946        |             |         |
| 88  | 1    | 1945        |             |         |
| 89  | 1    | 1944        |             |         |
| 90  | 1    | 1943        |             |         |
| 91  | 1    | 1942        |             |         |
| 92  | 1    | 1941        |             |         |
| 93  | 1    | 1940        |             |         |
| 94  | 1    | 1939        |             |         |
| 95  | 1    | 1938        |             |         |
| 96  | 1    | 1937        |             |         |
| 97  | 1    | 1936        |             |         |
| 98  | 1    | 1935        |             |         |
| 99  | 1    | 1934        |             |         |
| 100 | 1    | 1933        |             |         |

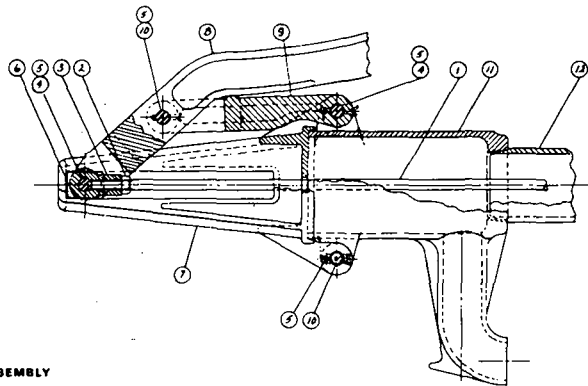
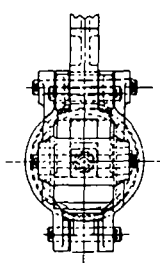

OPTION B  
OPTIONAL VIEWS SHOWING  
PIN MOUNTED PUMP CAP

NOTE:  
ALL PARTS NOT SHOWN BEING ARE THE SAME  
AS LISTED IN ASSEMBLY ABOVE

| NO. | QTY. | DESCRIPTION | UNIT | REMARKS |
|-----|------|-------------|------|---------|
| 11  | 1    | 2016        |      |         |
| 12  | 1    | 2015        |      |         |
| 13  | 1    | 2014        |      |         |
| 14  | 1    | 2013        |      |         |
| 15  | 1    | 2012        |      |         |
| 16  | 1    | 2011        |      |         |
| 17  | 1    | 2010        |      |         |
| 18  | 1    | 2009        |      |         |
| 19  | 1    | 2008        |      |         |
| 20  | 1    | 2007        |      |         |
| 21  | 1    | 2006        |      |         |
| 22  | 1    | 2005        |      |         |
| 23  | 1    | 2004        |      |         |
| 24  | 1    | 2003        |      |         |
| 25  | 1    | 2002        |      |         |
| 26  | 1    | 2001        |      |         |
| 27  | 1    | 2000        |      |         |
| 28  | 1    | 1999        |      |         |
| 29  | 1    | 1998        |      |         |
| 30  | 1    | 1997        |      |         |
| 31  | 1    | 1996        |      |         |
| 32  | 1    | 1995        |      |         |
| 33  | 1    | 1994        |      |         |
| 34  | 1    | 1993        |      |         |
| 35  | 1    | 1992        |      |         |
| 36  | 1    | 1991        |      |         |
| 37  | 1    | 1990        |      |         |
| 38  | 1    | 1989        |      |         |
| 39  | 1    | 1988        |      |         |
| 40  | 1    | 1987        |      |         |
| 41  | 1    | 1986        |      |         |
| 42  | 1    | 1985        |      |         |
| 43  | 1    | 1984        |      |         |
| 44  | 1    | 1983        |      |         |
| 45  | 1    | 1982        |      |         |
| 46  | 1    | 1981        |      |         |
| 47  | 1    | 1980        |      |         |
| 48  | 1    | 1979        |      |         |
| 49  | 1    | 1978        |      |         |
| 50  | 1    | 1977        |      |         |
| 51  | 1    | 1976        |      |         |
| 52  | 1    | 1975        |      |         |
| 53  | 1    | 1974        |      |         |
| 54  | 1    | 1973        |      |         |
| 55  | 1    | 1972        |      |         |
| 56  | 1    | 1971        |      |         |
| 57  | 1    | 1970        |      |         |
| 58  | 1    | 1969        |      |         |
| 59  | 1    | 1968        |      |         |
| 60  | 1    | 1967        |      |         |
| 61  | 1    | 1966        |      |         |
| 62  | 1    | 1965        |      |         |
| 63  | 1    | 1964        |      |         |
| 64  | 1    | 1963        |      |         |
| 65  | 1    | 1962        |      |         |
| 66  | 1    | 1961        |      |         |
| 67  | 1    | 1960        |      |         |
| 68  | 1    | 1959        |      |         |
| 69  | 1    | 1958        |      |         |
| 70  | 1    | 1957        |      |         |
| 71  | 1    | 1956        |      |         |
| 72  | 1    | 1955        |      |         |
| 73  | 1    | 1954        |      |         |
| 74  | 1    | 1953        |      |         |
| 75  | 1    | 1952        |      |         |
| 76  | 1    | 1951        |      |         |
| 77  | 1    | 1950        |      |         |
| 78  | 1    | 1949        |      |         |
| 79  | 1    | 1948        |      |         |
| 80  | 1    | 1947        |      |         |
| 81  | 1    | 1946        |      |         |
| 82  | 1    | 1945        |      |         |
| 83  | 1    | 1944        |      |         |
| 84  | 1    | 1943        |      |         |
| 85  | 1    | 1942        |      |         |
| 86  | 1    | 1941        |      |         |
| 87  | 1    | 1940        |      |         |
| 88  | 1    | 1939        |      |         |
| 89  | 1    | 1938        |      |         |
| 90  | 1    | 1937        |      |         |
| 91  | 1    | 1936        |      |         |
| 92  | 1    | 1935        |      |         |
| 93  | 1    | 1934        |      |         |
| 94  | 1    | 1933        |      |         |
| 95  | 1    | 1932        |      |         |
| 96  | 1    | 1931        |      |         |
| 97  | 1    | 1930        |      |         |
| 98  | 1    | 1929        |      |         |
| 99  | 1    | 1928        |      |         |
| 100 | 1    | 1927        |      |         |

FIGURE 2. DEEP WELL PUMP ASSEMBLY

|  |   |  |   |
|--|---|--|---|
| APPROVED: _____<br>DATE: _____<br>TITLE: _____ | PREPARED BY: _____<br>DATE: _____<br>TITLE: _____ | CHECKED BY: _____<br>DATE: _____<br>TITLE: _____ | PARTS LIST<br>HAND PUMP ASSEMBLY<br>DEEP WELL TYPE<br>E 79986 406 P948-0001-2002<br>6-23-78 |
|--|---|--|---|

# 4. TOGO, USES OF DYNAMITE IN LARGE BORE WELLS PCV Christopher Henney, 1974

PART I: Obtaining it

## When to use dynamite

When and if you encounter a hard rock layer and there is NO OTHER WAY to break it in order to attain the aquifer, then dynamite is in order. Of course, you could move the well site, but in some regions this probably would not make much difference. Never use dynamite before it is absolutely necessary as villagers will immediately start to rely on it as soon as the going gets rough. It is very difficult to stop using it once you have started. Dynamite in an old well or using dig-a-meter-pour-a-meter method. Start with small charges and deep blast holes and try to leave 50 cm between caissons and rock.

## How to get it

Because it is an extremely dangerous substance and can be used for sabotage or other crimes, most governments are very cautious about whom they give permission to use dynamite; thus one's procedure for obtaining it should always be through all necessary official channels. In Togo this generally means:

- 1) Chef-Cir
- 2) Travaux Publics  
or Assainissement
- 3) Interior Ministry
- 4) An authorized dealer

First you get your Chef-Cir to address a "demande de permission d'achat" permission to buy request to the Minister of Interior. This will state quantity and type of dynamite plus quantity and type of detonators. What purpose it is to be used for and where; where it will be kept, and by whom. Attached to this should be an agreement of your local boss; in my case the Engineer of Assainissement, Sokode. This letter will then be transmitted to Lome (the capital) and will be returned as a letter of permission to the bureau of the Chef-Cir. He will give it to you. Remember this permission expires after six months, so use it immediately. With this letter you then go to Lome and order the dynamite and detonators from Brossette et Valor (an authorized dealer). This could take time as it must come from France. So plan 6 months ahead.

Another option is to have Travaux Publics-Service Hydraulique order it for you when they order theirs. Especially if you only want one or two cases. This is because Brossette requires a minimum order of three cases unless you want to wait until it can be attached to someone else's order. This also has the advantage of free transport up-country. It is not always easy to get a transporter to carry high explosives.

WHAT TO ORDER:

The Dynamite

There are a number of kinds of dynamite or explosives adaptable to wells. And the choice is probably best made with expert help. Service Hydraulique is your best bet or Service des Mines. After using three different types and talking to a number of people, I decided on the type known as "Gomme A" Tolamite. This is a redgelatinous substance rolled into 50 grms. packages by means of wax paper. It is waterproof and maleable. The gases it releases upon ignition are non-toxic (although they may irritate lungs, but I will get to that later) and the stuff won't go off if bumped, smashed, dropped, etc. The maleability is important as sometimes you want to squeeze it into a crack like toothpaste. I generally figure quantities on this scale:

1 charge = 50 or 100 grms. dynamite

| <u>Meters</u><br><u>depth of</u><br><u>rock</u> | <u>Diameter</u><br><u>of well</u> | <u>Quantities</u> | <u>Number of</u><br><u>blast holes</u> |
|---|-----------------------------------|-------------------|--|
| 1 METER   | 1 meter $\emptyset$               | 12 charges        | 3                                      |
| 1 METER   | 1 meter 25 $\emptyset$            | 10 charges        | 5                                      |
| 1 METER   | 1 meter 40 $\emptyset$            | 24 charges        | 6                                      |
| 1 METER   | 1 meter 80 $\emptyset$            | 28 charges        | 7                                      |

This should be more than adequate; usually it takes two rounds of explosions to do a meter although this depends on the depth of the blast holes and the hardness of the rock. Normally your local water bureau or Travaux Publics will be able to tell you how deep you will have to blast. One case of dynamite weighs about 25-30 kg.

The Detonators

For each three charges, you will need two detonators. This will insure an adequate supply. Make sure they are electrical firing detonators. Fuses are dangerous and should not be used. The best kinds are type B66 low intensity, total resistance 1.5-3 ohms, medium 2 ohms. Make sure the wires are 2 m long.

In general both dynamite and detonators have an expiration date. So make sure you don't get an old batch, because it may be unstable and therefore DANGEROUS.

### Where to Store and How

The storage of dynamite is most important for your own health and that of others. Don't keep it at home as you may have kids or other curious people around. Personally, I prefer to keep it at the local gendarmerie, police or travaux publics. This has a number of advantages:

- a) You cannot be accused of sabotage for political reasons
- b) If you work on weekends, you can get it at the first two places
- c) If there is an accident, you are not around or responsible

Keep detonators away from dynamite, if possible at the other side of a locked room and in a case. Never let dynamite and detonators come into contact until you are ready to use them. Remember a good shock can set off the detonators, and detonators can blow your hand off. Keep tabs on how much you have and how much has been used. If you cannot keep it at the above mentioned locations, make sure you have a good store room with lock and the only key in your possession.

### How to Carry to your Site (If You Must)

If you don't want to keep it at the site because there is no adequate store room or you have many sites and prefer to bring it in when needed from a central store, then you must decide how it will be carried. I personally don't like this as there is a small amount of risk involved; but I did it for over six months. Anyway, if you follow certain simple rules, you should be all right.

- 1) Keep detonators and dynamite in separate waterproof sealed cans --The detonators preferably in a plastic one.
- 2) Keep the batteries or exploder somewhere else in your pack and separate from the detonators. This will insure you except if you get hit by lightning or squashed by a truck, both of which are very real dangers. A normal crash because of sand, etc., should cause you no problems. (I had two).

### PART II: How to Use

#### Rules for Use in a Well

The use of dynamite follows a couple of rules of thumb:

- a) Use common sense
- b) Don't use more than needed to get the job done
- c) Make sure the site is cleared of people

- d) Keep children away from site at all times
- e) Get someone else to trigger it
- f) Don't let anyone else handle dynamite or detonators
- g) Keep the batteries in your pocket or pack until you are out of the well and the site is cleared
- h) Check whether all charges went off (see Part III)
- i) Never send someone else to get dynamite or detonators from the store room
- j) Never go down in a well containing unfired charges unless you have secured the batteries
- k) Place the charges yourself.

Rules a, b, c, d, g, j are constants, but e, f, i, k are changeable if you have trained a competent person to do the job. But no matter what happens, you will always be held responsible.

### Tools You Need

Assuming you are working on a village level and you don't have a jack hammer (compressor), you will need:

- 1) Mining bar
- 2) 75 meters of extension cord flex
- 3) 1 roll of insulation tape
- 4) 1 flat file (to sharpen mining bar)
- 5) 5 flash light 1.5 volt cell batteries, size D
- 6) Dynamite and detonators
- 7) One 2-meter spoon

### How to Place Charges

As I have said before, the number of charges is in proportion to the depth of the blast holes and the diameter of the well. A good rule of thumb is two charges per hole (blast hole) and:

- 3 holes for 1 m  $\emptyset$
- 5 holes for 1 m 25 cm  $\emptyset$
- 6 holes for 1 m 40 cm  $\emptyset$
- 7 holes for 1 m 80 cm  $\emptyset$

but depending on the rock, you may have three charges per hole (or one). Never blast if your holes are not deep enough. It is a waste of dynamite. The blast holes should be at least the length of a man's arm, 80 cm and preferably more. The deeper the better. Blast holes should always be in the most protruding places.

Figure A.

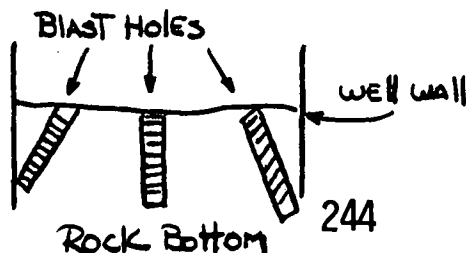

Here is a good diagram of where to place them in general:

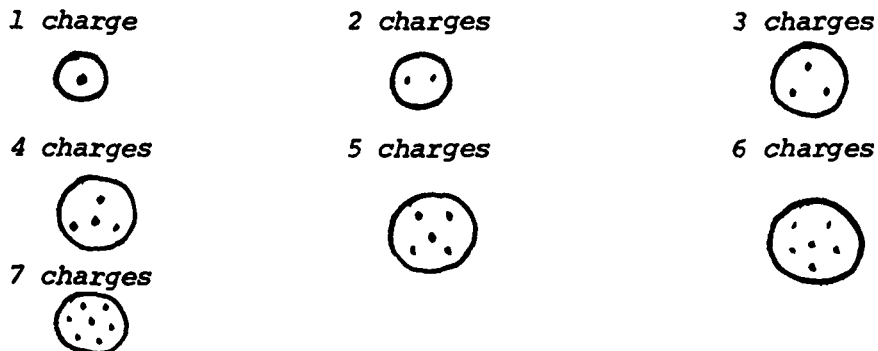

The charges toward the outside walls of the well should slope out as in Figure A and in the case of 4 - 1 charges.

How to Make up Charges

There are two methods that I use: placing side by side, or one on top of the other.

Figure B.

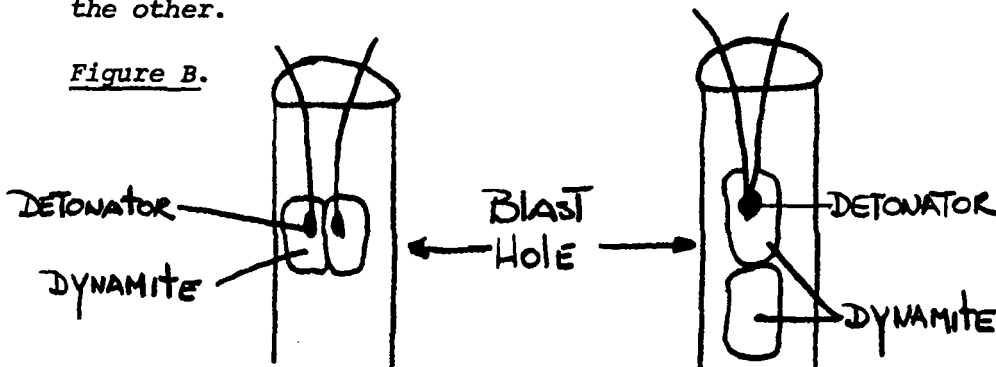

I prefer the side by side method where the hole is large enough. This is done by unwrapping the wax paper around the dynamite and sticking the two charges together, then rewrapping. The detonator is then inserted until completely inside the dynamite. This method has the advantage of never having only one charge go off because the other got covered by mud and separated from the first charge as in the one on top of the other method. But in really hard rock it is sometimes not always possible to make the blast hole wide enough. The one on top method is also better for really deep holes as you can put 3-4 charges in with no difficulty. I might also mention that the tighter the fit of the dynamite, the better blast you are going to get. Once the dynamite is in the hole with the detonator securely in the dynamite, pack the hole with damp sand. And pack the sand with a stick so it is well in and well packed.

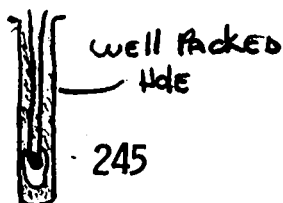
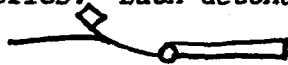



Figure C.

Don't pussy-foot but don't pound as if you were driving railroad spikes. This insures that the dynamite has something to push off on and that the gas does not escape out the open hole. Never fill your hole up to the top with dynamite. This just is a noisy waste.

If you have more than one charge as you will most of the time, you must hook them up in series. Each detonator has two wires, on one will be a flag.



Now in order to hook up a series, you must hook flag to non flag of another charge:

This leaves you with one flag and one non flag which is then attached to the extension cord that goes above ground. Next collect your ends and tie them to the extension cord:

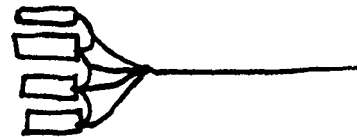

If you have four detonators, there should be five joints left out of the knot, and so on. Make sure these are separated so as not to cause a short circuit.

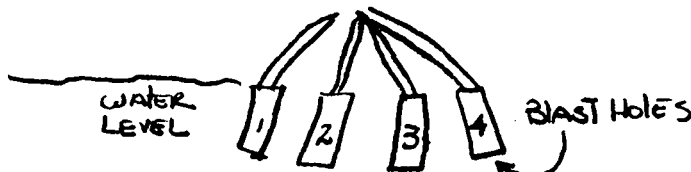

Also make sure that this knot is above the water level---Preferably as high as possible without pulling the detonators out - and that is easier than imagined even when the charges are packed in sand. Then get out of your well, being careful not to pull on the extension cord.

How to Dig the Blast Holes

Using the blade end of the mining bar, pound the rock. This must be done while continually rotating the blade so as to make a nice neat round hole. At intervals, add water to make a slurry - this is messy but necessary. After a bit, use the 2 meter long spoon to get out the dust and dirt made from pulverized rock; or if the hole is wide enough, use your hand. Never make holes wider than your hand (fist) as this is just wasteful of dynamite.

The sand will be blown out and little rock will be blasted. This is hard work and can take several days.

### Ignition

To set off the dynamite, place the four or five batteries end to end and touch the two ends with the two ends of the cord. Make sure you do this firmly and keep the cord touching until you have counted five (even though the explosions will happen spontaneously). This could save you many hours of looking for live charges that did not go off. For 1-3 charges, four batteries. Add one battery for every additional charge; i.e. for 5 charges, 6 batteries; for 6 charges, 7 batteries, and for 7 charges, 8 batteries.

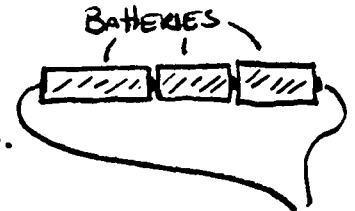

Before you fire, clear the site. Let no one stand nearer than 50 meters to the well. Let a Togolese do the firing. There are two reasons for this. If someone gets hurt you did not pull the trigger, and Togolese-American relations will not be upset. Also, you are needed to keep a sharp look out for falling rocks, impulsive children, or new arrivals. But if anything does happen, you will still be responsible for the site and though not legally, you will be held responsible in the eyes of the people you are working with.

Once the explosion has gone off wait a minute. You will often be surprised how long it takes rock to fall back to earth. Then pull up the extension cord and count the number of detonator wires. If all have gone off great, but if one is severed half way up, there is a chance it is still alive. Also, if there is anything holding the cord don't yank it up. This could well be the wire that did not fire, and by following it you will easily find the unfired charge instead of digging all over to find it. Now wait 15 minutes - half an hour until the smoke clears. You can choke to death by smoke inhalation even if the smoke is not toxic per se.

### What to Do if a Charge does not go off

First, climb down and check your detonator wires. If one stays stuck, dig around it reasonably carefully. (If an explosion could not set the charge off, you would really have to try). There is not too much danger if you are careful. When you reach sand, pull the detonator out slowly, then dig out the charge. The charge is now harmless. Or you can also rewire the detonator, climb out, and fire it. If this does not work and you cannot extract the charge, put a new one in on top of it and fire that. This way your well is clean. Then send workers down but NOT until you have at least extracted the detonator(s).

The causes of unfired charges are:

- 1) A short circuit
- 2) A set of old batteries (no power)
- 3) Old detonators

After each explosion, check out your cable and patch or cut. Then place batteries at one end and the two wires on your tongue at the other end; if it tingles, all is well. Coil and put away. If not, find the short. Always do this after each explosion. It saves embarrassment when nothing goes off. You can work in up to 1 meter of water.

### Recap of Procedure Rules

- 1) Only use dynamite where nothing else works.
- 2) Never use before it is absolutely needed, even when the work is hard.
- 3) Follow all official procedures in obtaining it.
- 4) Make sure it is not outdated stuff.
- 5) Never use fuses, always electric detonators.
- 6) Don't keep it at home, store safely.
- 7) Never send an inexperienced person to get it out of storage. Go yourself.
- 8) Keep dynamite separate from detonators and detonators separate from batteries.
- 9) Use commonsense (take all the risks that need taking yourself).
- 10) Don't use more than you have to.
- 11) Make sure the site is cleared of people.
- 12) Keep children away from site.
- 13) Get someone else to fire it while you watch.
- 14) Don't let others handle dynamite or detonators or batteries.
- 15) When you are in well, keep batteries in your pocket. This is your only insurance.
- 16) After explosion, check for unfired charges.
- 17) Never go after unfired charges unless you have secured the batteries.
- 18) Place all charges yourself.
- 19) Always pack some sand on top of a charge.
- 20) Make sure your detonators are wired properly and that the jointed ends don't touch.
- 21) Tie the wires to the cord.
- 22) Make sure knot is above water.
- 23) Don't pull on cord. You might extract detonators by accident.
- 24) Let no one stand closer than 50 m when you blast.
- 25) Touch batteries firmly. Count to five.
- 26) Check for dead charges yourself.
- 27) Wait for smoke to clear.
- 28) Check extension cable after each explosion.
- 29) Keep tools in good repair.
- 30) Remember you are responsible for your life and other lives.

**PLEASE NOTE:** Under no circumstance should dynamite be used unless an exhaustive study concerning its use has been conducted by experts who are knowledgeable in the use of dynamite.

**GOOD LUCK AND TAKE CARE.**