



Aga Khan Planning and Building Service, Pakistan
Building and Construction Improvement Programme – BACIP

BACIP HOUSE IMPROVEMENTS

AN OVERVIEW OF NEW PRODUCTS (END 1999)



Sjoerd Nienhuys
BACIP Programme Director

Drawings by:
Sjoerd Nienhuys
Mubarak Ahmed, Gilgit

February 2000

TABLE OF CONTENTS

A. INTRODUCTION.....	1
B. BACIP APPROACH – DEMAND DRIVEN MECHANISMS.....	2
WORKING METHODOLOGY	2
ENTREPRENEUR TRAINING	3
PLANNING.....	4
PROMOTION	4
PRODUCT DEVELOPMENT.....	4
INVOLVING WOMEN	4
C. PROGRAMME ACTIVITIES	5
ROOFS AND CEILINGS	6
STOVES AND CHIMNEYS.....	7
WINDOWS AND DOORS	7
FOUNDATIONS AND RETAINING WALLS	8
WALLS AND WARDROBES	9
FLOORS AND FURNITURE.....	9
SPACE PLANNING	10
WATER AND SANITATION.....	11
POWER AND ENERGY	12
OTHERS AND TOOLS	12
D. DESCRIPTION OF IMPROVEMENTS.....	13
<i>Square Corrugated Metal Sheet Floors (1.0 Refers)</i>	14
<i>Leakage Control (1.1 Refers)</i>	15
<i>Roof and Floor Beams (1.2 Refers)</i>	18
<i>Composite Roof and Floor Beams (1.2.1 Refers)</i>	18
<i>Bowstring Beams (1.2.2 Refers)</i>	19
<i>Roof Hatch Window (1.4.1 Refers)</i>	19
<i>Dust-Free Ceilings (1.6 Refers)</i>	22
<i>Roof Insulation (1.7 Refers)</i>	22
<i>Under Corrugated Galvanised Iron (GI) Roof Sheets (1.7.1 Refers)</i>	22
<i>Over Corrugated Galvanised Iron (GI) Roof Sheets or Concrete (1.7.2 Refers)</i>	23
<i>Stoves for Cooking and Heating (2.1 Refers)</i>	24
<i>Improved Sun-Side Window (3.1 Refers)</i>	28
<i>Improved Shadow-Side Window (3.2 Refers)</i>	30
<i>Curtained Window (3.3 Refers)</i>	31
<i>Damp-Proofing Foundations (4.6 Refers)</i>	32
<i>Galvanised Wire-Mesh Wall Reinforcement (5.1 Refers)</i>	33
<i>Thermal Insulation Walls (5.6 Refers)</i>	36
<i>Storage for Bedding (6.6.1 Refers)</i>	38
<i>Storage Containers for Food (6.6.3 Refers)</i>	39
<i>Rat Traps (6.6.5 Refers)</i>	40
<i>H-A Frame Chairs (6.7.1 Refers)</i>	41
<i>Classroom Tables (6.7.2 Refers)</i>	41
<i>Movable Bookcase (6.7.4 Refers)</i>	43
<i>Kitchen Work Top/School Science Table (6.7.5 Refers)</i>	44
<i>Kitchen Utensils Cabinet (6.7.6 Refers)</i>	45
<i>Space Planning (7.1 Refers)</i>	46
<i>Separation and Composting Toilet (8.2 Refers)</i>	47
<i>Illumination (9.1 Refers)</i>	49
<i>Fluorescent Tube Light Protection Cages (9.2 Refers)</i>	50
<i>Solar Lamps (9.3 Refers)</i>	50

LIBRARY IRC
 PO Box 93190, 2509 AD THE HAGUE
 Tel: +31 70 30 689 80
 Fax: +31 70 35 899 64
 BARCODE: 1751

E. OTHER BACIP PRODUCTS	51
<i>Earthquake Simulation Table</i>	51
<i>Wheelbarrow</i>	51
<i>L- and C-Shaped Cement Blocks</i>	52
<i>Cement Mortar and Concrete Quality Tester</i>	53
<i>Compacted Adobe Blocks</i>	54
<i>Solar Fruit Dryer</i>	55
<i>Public Address System</i>	56
<i>BACIP Blanket</i>	57
<i>Solar Tent for Building in the Winter</i>	57
F. BACIP CATALOGUE	59
ANNEXE I - CODE LIST HOUSE IMPROVEMENTS	60

ADDRESSES

Aga Khan Foundation (AKF)

12-Street 84, G-6/4

Islamabad

Pakistan

Telephone: +92 51 2276812-14

Fax: +92 51 2276815

Aga Khan Planning and Building Service, Pakistan (AKPBSP)

300/2 Garden East, Off Britto Road

Karachi 74550

Pakistan

Telephone: +92 21 7213797 / 7225574

Fax: +92 21 7225572

E-Mail: akpbsp.k@akpbsp.org

Aga Khan Planning and Building Service (AKPBS)

River View Road, Opposite FCNA Helicopter Chowk

Gilgit, Northern Areas

Pakistan

Telephone: +92 572 55889 - 55388

Fax: +92 572 55890

E-Mail: akpbs@glt.comsats.net.pk

Building and Construction Improvement Programme (BACIP)

River View Road, Near Chinar Bagh Bridges

Gilgit, Northern Areas

Pakistan

Telephone: +92 572 2819 - 2954

Fax: +92 572 2819

E-Mail: bacip1@glt.comsats.net.pk

**For further information, contact Syed Fakhar Ahmed at BACIP office or via e-mail:
bacip1@glt.comsats.net.pk**

BACIP HOUSE IMPROVEMENTS

An Overview of New Products (End 1999)

A. INTRODUCTION

The Building and Construction Improvement Programme (BACIP), a project of the Aga Khan Planning and Building Services for Pakistan, is operating in the Northern Areas and Chitral. The programme is an applied research project to establish new methods of house improvements and service delivery to remote villages, communities and individuals on a cost-effective basis. The services are in the fields of house and cluster planning, and entrepreneur development. The methods should be feasible for application in more than 1000 villages, many of them without access by light truck roads.

The programme's objectives are to improve the living conditions of rural people in (remote) mountain areas having limited access to information and/or building materials. Traditional houses are characterised by dark, smoky, unventilated and humid conditions, with poor storage and sanitation facilities. The present and past construction of traditional houses is of very poor structural quality, often with loose masoned stone construction that will collapse in minor earthquakes and through annual erosion. Masons who copy techniques from down-country (the large cities) often build with cement blocks and reinforced concrete by which they increase the cost and reduce thermal comfort.

The project has developed a variety of practical and affordable house improvements to increase the comfort level in relation to thermal insulation issues, illumination and light, ventilation and space organisation. A new wire-mesh wall reinforcement technique has been developed, providing a simple, effective solution for the construction of better earthquake resistant houses. New houses are now being planned, incorporating various house improvements and the wire-mesh wall reinforcement technique.

By the end of 1999, more than 60 new design options had been developed and more than 30 of these designs were applied to houses in some 20 villages, to assess real user conditions and acceptability. The project staff is responsible for monitoring the improvements and obtaining feedback. Local craftsmen now regularly replicate more than 15 new designs that are energy saving and improve the quality of housing.

The present document gives an overview of the most relevant house improvements to date (end 1999). To arrive at these house improvements the following steps were followed:

- ◆ Assessment of current problems presented by the villagers themselves in relation to their houses and immediate environment.
- ◆ Definition of various solutions to the problem by either identifying existing solutions, best practices from the past, or designing new options.
- ◆ Assessment of the options on material use, financial feasibility and cultural acceptance.
- ◆ Manufacture of prototypes and field test the manufacturing process and functioning.
- ◆ Place models in the villages for monitoring and obtaining user comments.
- ◆ Eventually modify the model to adjust to individual needs and manufacturing technique.
- ◆ Organise promotional neighbourhood meetings to explain the advantages and disadvantages of the improvement products.
- ◆ Organise entrepreneur exchange training activities between skilled and local craftsmen.
- ◆ Organise the purchase and supply of essential materials required for the product.
- ◆ Make manufacturing, installation and maintenance/operational manuals in English and illustrated Urdu versions.

B. BACIP APPROACH – DEMAND DRIVEN MECHANISMS

The BACIP research activity is subsidised for the development of the products, as well as for the delivery and field testing of these new products in the villages. After that, the villager must finance the actual replication cost of the products or models.

The creation of a sustainable programme should be based on market mechanisms that are demand driven. As house improvement and construction are activities undertaken by individuals, these cannot be subsidised with public funds on a sustainable basis. The realisation of these individual activities needs to be financed by the clients themselves, whereas only the organisational aspects and the related research can be temporarily financed from external funds. The need for self-financing implies that the client (villager) should be served according to his/her choices and needs; otherwise the willingness to undertake the house improvements (with BACIP advice only) will not exist.

The above means that all BACIP improvements and house designs need to be tailored to the particular and individual needs of the client (the villager).

Working Methodology

*When BACIP staff communicate with a villager regarding an improvement, they should always ask what the needs of the individual are rather than **assume** what the problems are.*

Upon entering the pitch-dark room, we were immediately enveloped by a thick cloud of smoke. Eyes burning and tearing while stumbling over a pile of dirty bedding quilts, we were invited to have a cup of tea. Sitting against the ice cold wall, we proceeded to ask: "so, what is your problem?" Often the women then come up with issues that we would not immediately have thought of nor necessarily the most obvious.

Interestingly BACIP is finding solutions to some problems in other valleys or regions. This means that part of the activity of defining better solutions is to assess existing best practices from the region itself.

There are various reasons for the disappearance of some of the old and good building practices:

- ◇ People are no longer building their own houses in the tradition carried over from father to son. Instead intermediary craftsmen and local labourers (masons) have taken over many of these tasks.
- ◇ The best craftsmen have migrated to the major towns, taking their skills with them.
- ◇ New house owners/builders tend to contract local unskilled labour or craftsmen. To economise expenses, the choice is usually made for simple constructions, elimination of reinforcement and reduction of quality.
- ◇ New houses often are built with imported ideas from the cities, such as larger windows, without taking the different climate situation into consideration; hence a cold house in winter.
- ◇ New houses are often built with "fast" materials, such as cement blocks, that require additional insulation to make a comfortable accommodation. With lack of knowledge and trying to keep the cost down, the additional insulation measurements usually are not taken; hence a cold house.
- ◇ Large wood dimensions used for heavy roof construction supports are no longer available. The low quality poplar wood is not recommended for horizontal load bearing beams.

Although the BACIP Programme can depart from the designs as mentioned in this document, individual adaptation of these designs and detailed cost calculations must be provided. The efficiency of the Programme and the level of cost-recovery will depend largely on the number of services which can be provided simultaneously to each village. Improvements and service delivery should therefore be on a group basis. The group approach is an essential component of the BACIP plan for sustainability. Each village which is attended by BACIP must have a co-ordinator, local male and female resource persons for communication with the villagers, and a nearby trader or transporter. Village-based guest rooms have been established to accommodate BACIP staff and other consultants at low cost; thus minimising travel.

Entrepreneur Training

Neither the BACIP Programme nor AKP BSP can deliver house improvements to 100,000 households in the area (1.4 million inhabitants). Not the least because of its magnitude but foremost because of the cost aspects. An NGO cannot economically compete with the financial simplicity of the micro-entrepreneur. In general terms the micro-entrepreneur provides products at less than half or one-third the cost of an NGO because of the lower income levels of the employees and the very low overhead and administrative costs. For effective service delivery the NGOs must therefore mobilise the micro-entrepreneurs, rather than try to deliver the goods and services themselves. This mobilisation process involves training and learning methods that are cost effective and adjusted to the needs of these micro-entrepreneurs.

One of the most appropriate learning systems suitable for training the micro-entrepreneurs (both within the formal and informal sectors) is *exchange visits* whereby it has been suggested that *"the best trainers of entrepreneurs are other entrepreneurs and the best classroom is real productive work."* Therefore entrepreneur exchange visits are being organised for local craftsmen to be trained by more experienced "host" entrepreneurs in the manufacturing of the new BACIP house improvements desired by the villagers. In addition the method of self-help construction methods and self-help assembly of a number of articles is being explored.

The BACIP strategy is to provide access to improved and efficient designs (manuals), as well as quality building supplies at minimal cost. To provide low-cost house improvements on a self-help basis, essential building materials should be available at favourable prices to the villagers. Essential building materials are those materials which need to be imported into the region, without which no durable, quality improvements can be realised. Before the year 2000 no trading network existed for supplying materials according to the very dispersed demand. Thus, a trading network is being set up with local entrepreneurs that reaches all the way into the (remote) villages. The trading system must be based on private enterprise, using existing traders in the villages as much as possible. To avoid damage during transport on the rugged roads of the area, the improvement items need to be assembled on site as much as possible. This has resulted in knocked-down Assemble-It-Myself (AIM) packages, supported by step-by-step assembly manuals.

The designs and specifications of the models, as well as detailed drawings for manufacturing, will eventually be available from a BACIP catalogue located in each village. The catalogue will provide information on consultancies, contracting and micro-finance for the producers. In this way, the villagers can learn about other existing alternatives to solve their problems.

Resuming the above,

BACIP focuses on the **access to information and building advisory services** for low-income population.

BACIP strives to provide "affordable and appropriate solutions" to counter the problems that people are facing, from the individual to village level. These solutions will be based on a combination of traditional best practices and improved materials and techniques.

"Affordable and appropriate solutions" implies **informed choices** that will improve the living conditions of the families, in particular the women, and enhance the quality and durability of housing (e.g. earthquake resistant design).

Planning

In the area of planning, BACIP is working in various fields:

- ◆ Planning of new multi-storey houses together with the villagers, taking into consideration existing local features and sun orientation.
- ◆ Planning of changes and additions to houses, for example when people want to convert storage areas into a kitchen or add bathrooms, bedrooms and other quarters.
- ◆ Planning of two- and three-storey houses by using simple building techniques that are earthquake resistant and results in saving valuable agricultural land from being used for housing.
- ◆ Making lay-outs of existing village clusters in order to assess possible upgrading and the introduction of additional spaces (such as sanitation).
- ◆ Planning the upgrading of the village clusters so that reconstruction can take place in an organised manner without endangering the neighbouring houses.
- ◆ Participation of the women of the households in the planning process since they are the main users of the houses and have an in-depth knowledge of the best house organisation.
- ◆ Participatory village surveys that produce village hazard maps. These hazard maps will be used to review the potential hazards with the villagers and plan the least dangerous sites for new housing.

To aid in the above, a three-dimensional house planning tool has been developed by BACIP, which is described in a separate research report entitled: *The BACIP House Planning Tool (October 1999)*.

Promotion

To generate public interest for the BACIP house improvements and other services, travelling Road Shows were initiated to demonstrate the various BACIP products and techniques. Road Shows are now being held on a regular basis in new villages. The process and function are described in detail in the document: *BACIP Road Shows – A Manual on How to Organise a Road Show (January 2000)*.

Product Development

The methodology on how new products are developed in the BACIP Programme is described in the document: *BACIP Product Development – Description of the Methodology of Developing a Product for House Improvements (June 1999)*.

Involving Women

The methodology on how women are involved in the definition of new products and product promotion is described in the document: *BACIP House Improvements – Involving Women in the Market-Driven Product Promotion (May 1999)*.

C. PROGRAMME ACTIVITIES

The Programme's contact with the villages follows four phases:

- **Information**
 - Provide models of house improvements that can be seen in the village.
 - Provide knowledge about different improvement options through Road Shows.
 - Provide cross linkages with other villages in the region to learn from their solutions and to show them the newly developed BACIP solutions.
 - Disseminate an illustrated catalogue with technical and financial information about the improvements.
 - Develop other methods, such as radio programmes, to promote product information.
- **Awareness**
 - Understanding by the villager of the problems and their effect on the present housing.
 - Explaining the disadvantages of existing poor constructions, seismic risks, health hazards.
 - Understanding the possible effect of the proposed BACIP home improvements.
 - Understanding the advantages of the new house improvements in the field of comfort, health, efficient space use and safety.
 - Information on the cost of the new designs in terms of labour and material components. Not only in relation to the short-term cost but mainly on the medium-term.
- **Motivation**
 - Budget, cost planning with BACIP.
 - Need, prioritisation and progressive development of the improvements.
 - Affordability, progressive realisation according to available finances.
 - Status and quality of life as compared with neighbours.
- **Action:**
 - Selection of the affordable solutions or designs and timing.
 - Collection of materials.
 - Purchase of materials and tools.
 - Construction, establishing labour contracts for realisation.
 - Contracting of consultancies with service providers, such as planners.

During field visits to 30 villages in the three areas (Gilgit, Skardu and Chitral), an assessment was made of the existing problems. These were categorised into nine main areas, as presented in the table of Annexe I. From the same nine areas, several examples of the problems encountered and solutions created are provided in the following pages.

Roofs and Ceilings

Problems: Leakage, mainly through the thick mud roofs after rain and snowfall. Soaking of the thick soil layers of the roof. Water infiltration into the tops of the walls.

After prolonged rain or melting snow, the whole roof structure becomes soaked, resulting in leakage. This not only causes the wood and branches in the roof structure to rot, but the seepage water mixes with the black soot clinging to the ceiling (caused by smoke emitted from an improperly used *bukhari*) which then drips into the living area.

Other problems: Dust particles caused by rot and fungus. Insects constantly falling down from the ceiling.

When BACIP installed a model "suspended" ceiling from white painted hardboard, the room became lighter, cleaner and warmer all at the same time. The homeowner then bought additional boards and did the rest of the house at his own expense.

The permanent traditional open hole in the centre of the smoke blackened ceiling (roof) is often the only light and air ventilation source into the room. Smoke produced from the fire of the cooking stove rises and attempts to escape through this hole, but is pushed back by cold air falling into the room. Thus the whole room fills with smoke. In addition, as the hole is at the highest position of the roof, all the warm air disappears through it, making constant burning of the *bukhari* necessary in winter.

One villager commented that the BACIP roof hatch window not only saved at least half the amount of firewood, but made the room free from smoke. The additional light produced by the roof hatch window inspired the family to clean the room. Being cleaner and warmer, the family now spends more time in the improved room.

No knowledge about materials, construction techniques, costs or alternatives. Although in the past good construction techniques were practised and proper solutions were found for heat insulation, new building practises do not follow these older techniques. In some cases this is due to the fact that the traditional materials are no longer easily available (wood). In addition, the villagers have forgotten, or didn't know in the first place, the reasoning behind and benefits of older building designs and techniques and why these afforded comfort in the old homes.



Stoves and Chimneys

Problems: Smoke, poor ventilation, defunct cooking stoves and chimneys, improperly used stoves, open fires, back fall of cold air through the roof, and open roofs.

Most houses are filled with smoke, causing eye irritation, respiration problems and unhealthy living conditions, especially for young children and women who are almost permanently in this suffocating environment.

When BACIP presented a more durable stove, the villager wanted a cheaper stove. When BACIP presented a cheaper stove the villagers wanted all sorts of attachments. When BACIP presented a long stove they wanted it shorter and vice-versa. The result is that now more than ten different stove types have been developed each with their specific advantages and disadvantages. In addition a variety of attachments are available, including a water heating system.



Windows and Doors

Most traditional houses have only a single ceiling hole in the roof (18" x 18"). Building additional storeys is impossible with such a hole. In these older traditional houses, the addition of an extra floor will usually result in the ground floor becoming either an animal stable or a dirty disorganised pitch dark storage room. In newer constructions, the villagers are adding more and/or larger windows than in traditional houses, copying the idea from "modern" cities. These new houses are extremely cold because any generated heat escapes through the larger windows.

Good thermal improvements can be realised by introducing an additional set of glass frames to make double windows, utilising the existing window frames to fix the second glass frames. Changing the position of the fly screens and cleaning the glass can also help to obtain benefit from solar heat in the winter. Introducing outside shutters and inside curtains will substantially increase insulation.

Good quality wood for door and window frames is getting scarce and more expensive by the day. As excellent stone aggregates are available in the Northern Areas, the possibility should be explored to make high-density concrete door and window frames. These should have an inside surface of wood to avoid cold thermal bridges in winter.

Walls and Wardrobes

Problems: Unstable structures (earthquake/erosion), non-masoned stone wall construction with loose rubble in-fill, lack of tie-beams or floor diaphragms, poor foundations. Traditional bonding of the heavy stone walls with wooden tie-beams is no longer practised because of the high cost and low quality of the wood.

Many of the observed structures will certainly either partly or entirely collapse in the event of even a medium-size earthquake, possibly with thousands of victims. In the Northern Areas it is not the question of WHEN the earthquake will hit, but more WHERE it will hit.

The BACIP programme has developed an improved wire-mesh reinforcement technique for walls being built with little cement mortar. The galvanised reinforcement will resist corrosion and can be manufactured in each village. The positioning of cross walls or the realisation of built-in wardrobes can add to the structural stability of the houses and solve some of the thermal insulation and storage problems at the same time.

Stone walls have poor thermal insulation. Therefore BACIP has designed a few types of highly effective, low-cost wall insulation methods that can be applied to both existing and new houses. New houses are being copied from warmer climates, such as Islamabad, and being built with cement blocks which have a high heat transmission co-efficient; thus the rooms rapidly cool off in cold climates.

At a village monitoring visit during the winter we went from house to house looking at all the different house improvements. Often the type of improvement was not disclosed before entering a house. Some houses were colder than others, but this particular house was so toasty warm that we immediately wanted to take a rest to thaw out our numb feet. After inquiring about the BACIP improvement, it turned out to be the house with the new model wall insulation.

The lack of understanding of the physics of insulation, air circulation and heat transmission leads people to apply materials without understanding the disadvantages of these materials in terms of heat insulation and conservation. On the other hand, the BACIP team has found good examples of local material used in several villages and older structures. Exchange of information on this subject is essential.

Floors and Furniture

Heavy floors and roofs are a potential danger in earthquake areas as they have a large weight (mass) that causes tremendous horizontal forces on the wall structure in the event of horizontal accelerations. Especially the heavy reinforced concrete floor constructions, when made of poor quality, constitute a great danger during earthquakes. Reducing the weight is of high importance. The BACIP square corrugated metal sheet floor is not only one-third the weight of a five-inch concrete floor, but has a very slow failure characteristic. Plus, it saves on having to make a form work.

Common wooden school chairs always break at their seat joints. BACIP has designed a new chair that is easier to make, lower in cost and much stronger than the traditional design.

During a presentation some engineers did not believe in the new architecture of the chair. To demonstrate the strength, six of the non-believing engineers were asked to stand together on the single chair. The human pyramid could not break it and we had six more believers in the new design.

Space Planning

Problems: Poor house space planning. Peripheral storage rooms block all access to light and ventilation. Poor food storage causing vermin infestation. No ability for creating second stories. Tendency to build new houses on agricultural land.

In one house the woman wanted to increase her bathroom, but the only place for extension was a large store located next to it. The store was poorly utilised as various items were laying on the ground and one corner was consumed by an immense heap of dried cow dung (for fuel). The BACIP suggestion was to build a small dung shed outside the store that could be filled from the outside and "cakes" could be retrieved from the inside. In this way the bathroom could be extended within the existing outside walls of the house.

The old village centres consist of dilapidated houses and are often inhabited by the older generation who have no funds or ambition to build a new house. The units are characterised by lack of sanitation, no daylight and built over dark storage rooms and/or cattle sheds. These old units are gradually falling apart and are abandoned when the owners pass away. Local heritage sometimes causes multiple ownership and the disputed city cluster will remain abandoned for years. The recuperation of these areas is important as there is little appropriate land available for housing. However, the technology to build multi-storey constructions was unavailable and management in the villages lacked the experience to deal with the complex planning and ownership issues.

In Furfu village a reconstruction proposal was made for a group of families, starting first with a toilet block and then rebuilding a two-storey section. Once the new two-storey section is complete, the families can move into the new house and building can continue with other sections. The families thought it was impossible because of financial and time restrictions. It was carefully explained how they could do the reconstruction step-by-step, according to the seasons and available finances. Once the process was fully understood the group agreed to undertake the four-year activity that will eventually result in a new, comfortable and safe habitat.



COW IN ENTRANCE HALL TO THE HOUSE (FIRST FLOOR)

Water and Sanitation

Problems: Poor or non-existent sanitation in some houses, causing health hazards and very unsanitary situations near existing schools.

Noticing no toilet facilities in one cluster house, the BACIP team inquired of the homeowner how he solved his sanitation problem. It appeared that they had a "squatting room" which was, by the look and smell of it, rarely cleaned.

In one school we found four beautifully outfitted porcelain pour-flush toilets in a new ablution block. When asked to have a look, the school master had to go and search for the key. Naturally we questioned why the toilets were locked and not being used. Seems that the building of the ablution block by the government didn't include the necessary water supply system. So, the children were still using the field behind a stone wall for such necessities of life. In the summer they complained that there were too many flies, no wonder.

BACIP has reviewed the existing dry-pit composting toilet and developed a highly sanitary unit that could be used as both a toilet and bathing room. The dry system will supply an improved compost, without the flies.



IN-HOUSE OR ATTACHED LATRINE CALLED *CIUKAN* OR *CHASKA*
BUILT OVER COW SHED BELOW

Power and Energy

Problems: Poor illumination, no windows, no lighting fixtures, no electricity and blackened wall/roof structures due to smoke.

In those houses that are connected to the electricity grid, a single bulb or fluorescent tube light is always present. However, the voltage is usually too low to activate the fluorescent tube starter and the bulb is so dim that almost no domestic activity or reading can be done. Improvements will include whitewashing the walls to increase light reflection and a TL bulb with an electronic starter that ignites even with low voltage.

Others and Tools

A few BACIP designs are listed in this chapter, some of which are new tools required for the building process.

In one model roof hatch window house, the woman homeowner requested a fly screen. It was first puzzling because normally flies don't tend to fly down into the dark, but rather fly up towards the light source. A fly screen in the roof would thus trap the flies inside the house. On further investigation it was discovered that apparently drying sweet fruits on the roof attracted plenty of flies. BACIP therefore designed a fly-proof, dust-free solar dryer that solved the fly problem and improved the dried products at the same time.



D. DESCRIPTION OF IMPROVEMENTS

In the following paragraphs, a short description is presented on a number of house improvement items (from the list of Annexe I) that have been developed, tested and applied. For most of the described items the total development period is about one year, including the design, manufacturing, redesigning, manufacturing, placement in villages, monitoring, modifications, re-manufacturing, placement in other villages, monitoring, final design and development of manuals.

The above does not mean that the design is either complete or without future development. Each design will further evolve with the development of both the entrepreneurs and the client population. With an increasing economy the demands of the population will also increase, and more complex or more sophisticated articles will be required.

The above process has no end. It is the function of the local NGO (AKPBSP) to devise methods to let the process further develop and educate the local entrepreneurs in such a way that they will be able to realise product innovation on their own initiative.

To maintain the dynamics of the process, the villagers need to be informed about the possible products and have access to information.

It should be noted that for communication with the villagers, perspective and animated sketches (more than given below) are in the process of being drawn up. For manufacturers and contractors, even further detailed drawings and precise instructions on manufacturing techniques, along with lists of required materials and estimated costs, will be assembled. A catalogue with an overview of the new designs will be distributed to each core village. Interested entrepreneurs and contractors will be able to buy selected sets of drawings from the catalogue at photocopy cost.

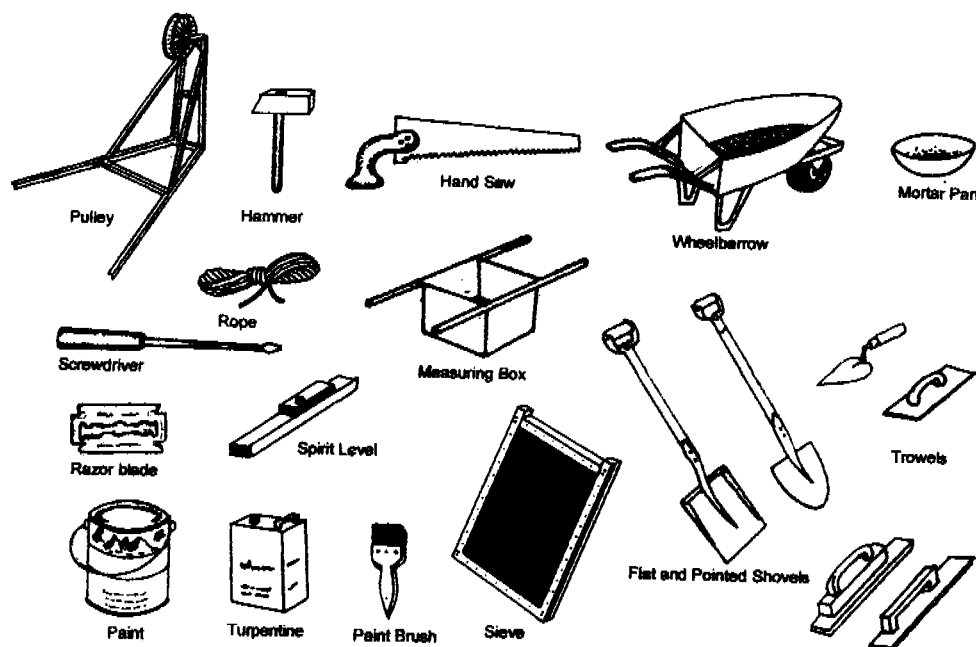

Square Corrugated Metal Sheet Floors (1.0 Refers)

Present reinforced concrete roofing and/or flooring is at least 5-6" thick and therefore quite heavy. Earthquake forces are directly related to the weight of the construction; the larger the weight, the larger the force. To reduce the floor weight and simplify construction, BACIP has introduced a lightweight concrete floor (or concrete roofing) with the aid of square corrugated metal sheets. The technology is commonly used in skyscrapers:

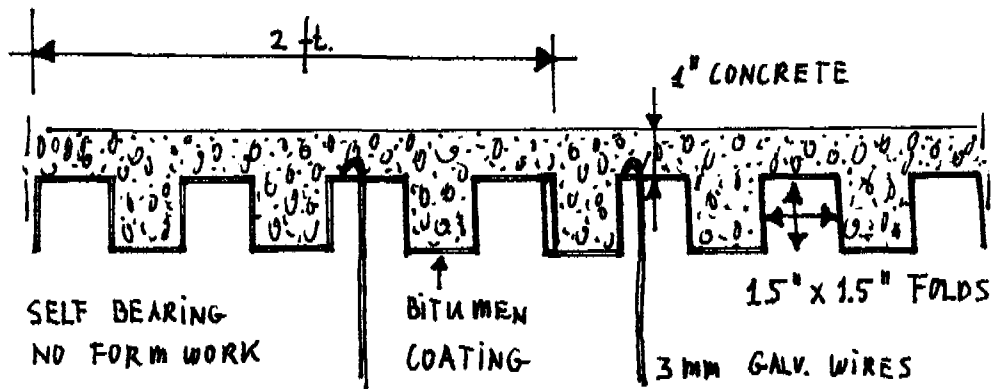

- ◇ The square corrugated metal sheets are of mild steel, 4 ft. by 8 ft. (maximum length of the local folding bench). These are the same metal sheets presently used for house and garage gates.
- ◇ The metal thickness is 20-gauge (0.92 mm). The square folds measure 1.5" in width and 1.5" in height.
- ◇ The working size of each square corrugated sheet is 8 ft. by 2 ft. (half the original width).
- ◇ Before casting, the future underside of the sheet is treated with a bitumen coating to avoid corrosion.
- ◇ A single sheet can have an 8 ft. span before casting and can support a load of 1000 kg.
- ◇ No form work is required for the casting of the concrete on these square corrugated sheets.
- ◇ The sheets are linked to each other or to the walls on their supports and are cast with a top layer of concrete only 1" thick.
- ◇ The cast sheet (8 ft. x 2 ft.) with an inch layer of concrete over the folds weighs about 180 kg, including the metal sheet. This is about one quarter the weight of a common reinforced concrete floor.
- ◇ When 1" of concrete is cast over the square corrugations, the single sheet (8 ft. x 2 ft.) can still support a 1000 kg load. Being now very stiff, it is ideal for flooring and roofing.
- ◇ The bonding between the square corrugated sheets and the concrete is very intense and no additional "positive moment" reinforcement with steel bars is necessary.
- ◇ For "negative moments" over supporting points, some additional reinforcement may be applied.
- ◇ Lengthwise the sheets can be connected with metal straps and anchored to the supporting beams. Straps from each sheet hook over the supporting beam, thus making a full and thorough connection.
- ◇ The special advantage of using these sheets is their integral coherence and low weight as compared with common reinforced concrete floors; thus reducing earthquake loads.
- ◇ The structure has a very slow failure characteristic and is able to absorb large deformation.
- ◇ A suspended ceiling can be easily fitted to the sheets. Before casting, 4 mm holes need to be drilled in the tops of the square corrugations and 3 mm hot-dip galvanised wires hung down through the holes. A suspended ceiling can then be hung from the wires.

Leakage Control (1.1 Refers)

One of the major problems encountered by the inhabitants in the Northern Areas is leaking roofs, either after rains or with snow covering. The present structure consists of a flat roof with three layers – (from bottom to top) branches with leaves, pressed grass and a clay soil topping – supported by wooden roof beams constructed on top of loosely bonded stone walls. In a few cases a thin plastic sheet has been introduced between the soil layers. Most of these roofs have no or very little slope or pitch. The roof is used for many purposes, such as for storage of harvested crops and drying of fruit.

When the rain wets the clay soil layer, it expands and forms a water barrier. After the layer dries, it cracks and provides an entry for new rainwater. With frequent rain or melting snow, the layers get saturated and water begins to penetrate the roof. Leakage then occurs (bringing with it the black soot that has accumulated on the ceiling). The wet roof reduces the thermal insulation, causing internal condensation in the roof and adding more water. The water-soaked roof becomes extremely heavy and constitutes an earthquake danger, especially when the beams start to rot. Humidity causes fungus and eventually dangerous allergies and/or respiratory diseases.

A leaking roof is not the only problem. Because there is no drainage overhang, rainwater runs down the outside walls, seeping into them and causing not only additional dampness in the house but structurally weakening the wall as it washes the soil away. In addition the wet walls cause the beams which are supported in the tops of the walls to rot.

Traditionally a number of solutions based on local construction techniques are being applied to try and rectify the situation, but many have proven inefficient or non-durable, such as:

- Brushing the top layer of clay soil with an apricot wash to make the roof top impermeable against rain showers. The apricot wash must be applied yearly to be effective. However, it is a seasonal product and available in insufficient quantities. In many areas it is not available at all.
- Using birch bark on top of the branches in the roof structure to make it more waterproof and lessen condensation. While birch bark has proven to be a good solution and also avoids condensation inside the room, the availability is now limited causing it to be considerably more expensive than plastic.
- Parapet walls and stones to stop water seepage. As such there is no adequate local solution to avoid water seepage into the tops of the walls which cause dampness and erosion.
- Usually over the years additional layers of soil are added to waterproof the roof. This does not work adequately and increases the roof weight excessively.
- Introducing a thin plastic sheet to stop leakage. While this is a good waterproofing technique, it is only effective if the plastic sheets are laid perfectly smooth and the water drains towards gargoyles (water spouts) or roof drainage points. Equally important is covering the plastic with a smooth soil layer, draining towards the lowest points. When the plastic is poorly applied, it forms dips in which water can collect and cause concentrated, long-lasting leakage points. If the plastic is placed uncovered on the roof top, ultra-violet light will rapidly destroy the sheets, requiring yearly replacement of the plastic. Often only thin plastic is available in the local market, which can easily be damaged with small punctures during manipulation. Little holes in the plastic (thin or thick) are unavoidable.

ROOF PLASTIC

EXAMPLE HOUSE A



USE LEVEL AND LONG STRAIGHT PLANK TO CONTROL SLOPE 1 - 2%

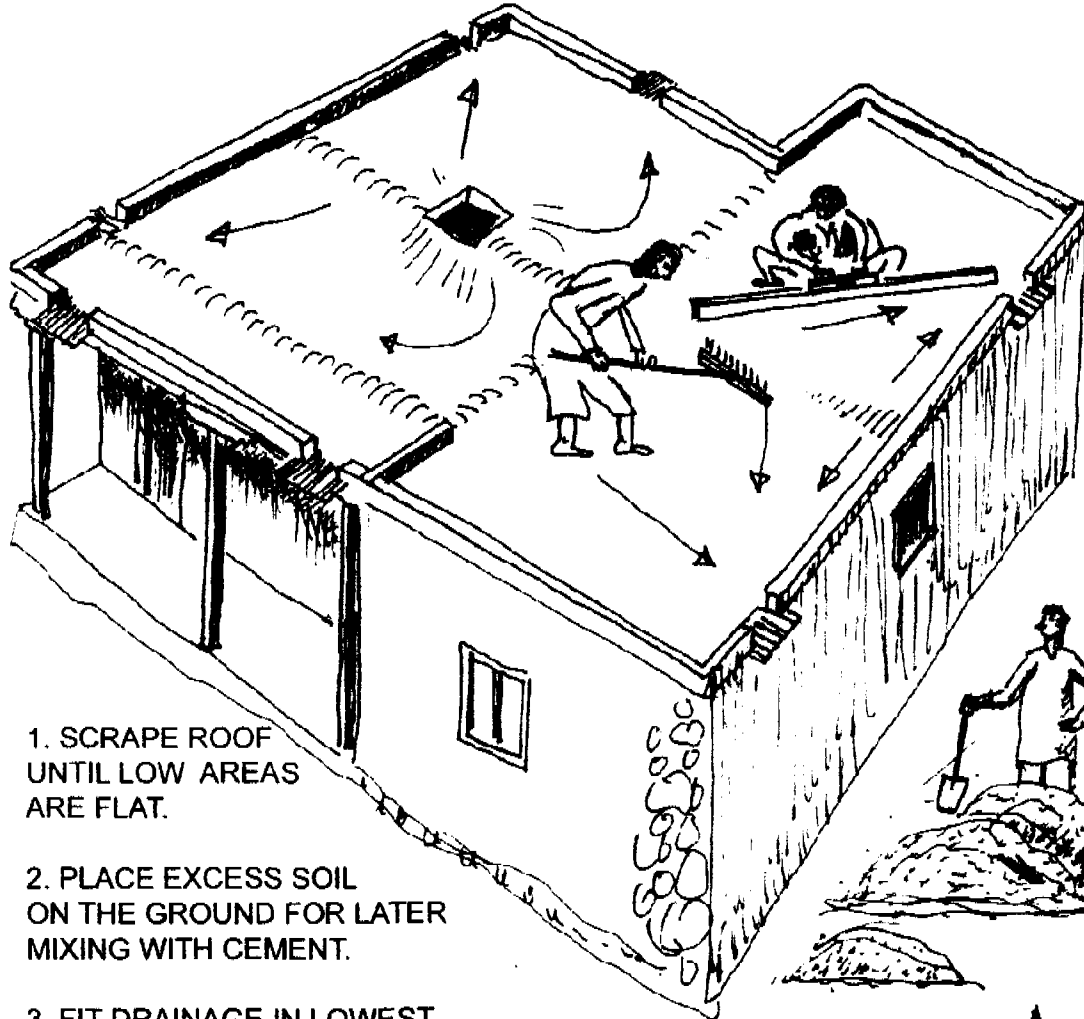

1. SCRAPE ROOF UNTIL LOW AREAS ARE FLAT.

2. PLACE EXCESS SOIL ON THE GROUND FOR LATER MIXING WITH CEMENT.

3. FIT DRAINAGE IN LOWEST POINTS.

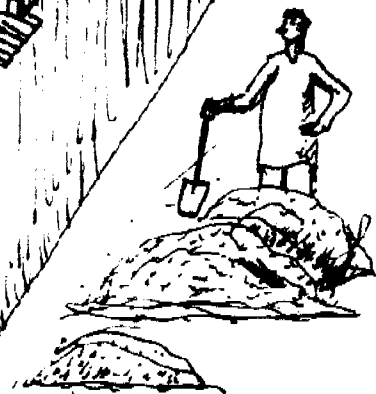

↑
EXCESS SOIL

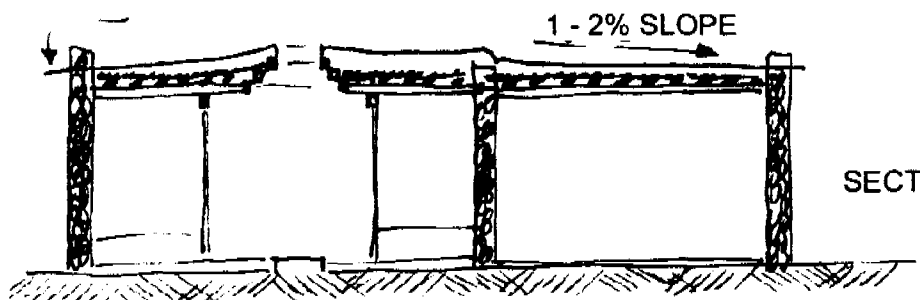

1 - 2% SLOPE

SECTION OVER ROOF

A PAGE OUT OF ROOF WATERPROOFING INSTRUCTION MANUAL

After analysing construction techniques, availability of materials and the budget of individual householders, it was evident that reconstructing the roofs in most cases would be out of the question. The advantage of the BACIP recommended procedure is that only the top layer needs to be partially removed for the making of a precise slope and reducing some of the massive roof weight. The new top layer is then smoothed and compacted with the aid of a straight edge to avoid any dips. The smooth surface is then covered with a 100 micron (0.1 mm) polythene sheet, followed by a layer of stabilised topsoil (ratio: 1 cement to 18 soil). The stabilised topsoil is also compacted. To protect the stabilised topsoil from evaporation and rapid drying in the warm season, the fresh cast should be covered with wet BACIP blankets. The same blankets can be used in the winter to keep the temperature of the fresh cast above 10° Celsius and avoid evaporation and under-cooling at night.

As 100 micron polythene plastic was unavailable in the local market, BACIP supplies it through local traders. Besides the blue recycled 100 micron plastic sheet, a thicker (150 micron) transparent plastic is also being supplied (more expensive but preferred by many villagers). A special roof-surface scraper tool has been developed and a flat edge shovel can be supplied to ease the work. In addition a hoist wheel has been manufactured for lifting materials onto the roof. The same hoist wheel can be used for the construction of two-storey buildings. The complete set of BACIP tools and blankets for roof waterproofing will be available through the village co-ordinator on a rental basis.

To avoid water seeping into the walls, a one-foot wide overhang at the draining side of the roof was made from corrugated sheets. Gargoyles, to project water away from the wall, have been manufactured from a flat piece of galvanised steel sheet. The plastic foil, gargoyles and drainage pieces can be bought through the village co-ordinator.

To disseminate the knowledge of roof reparation and create a demonstration effect, all community members are encouraged to participate in the installation of the first model improvement. Once the roof improvement is completed, the house owner is required (by contract) to brief the neighbours and other residents of the village on the improvement and allow them to see the advantages of the improvement firsthand.

Quote: "My house is now drier and warmer, in addition it smells better."

A dry roof and walls leads to a drier house and consequently the disappearance of some of the fungus, persistent rotting and wet soot aromas which normally perfume the living quarters.



THE PRECISE SLOPE IS ESSENTIAL FOR WATERPROOFING

Roof and Floor Beams (1.2 Refers)

In the past whole tree trunks were used, fitted one over the other, for supporting the heavy soil laden traditional roof structures. This wood is no longer available. Now the rather poor quality poplar wood is used and roofs need to be replaced every 15 years. As an alternative, lightweight corrugated galvanised roof sheets are being used. The disadvantage of galvanised roof sheets is that the roof cannot be used for daily activities or storage; thus depriving the villager from useable space. The need for strong beams is required that can carry heavy floors. The need for longer (20 ft. and more) beams and trusses is required for community halls and schools.

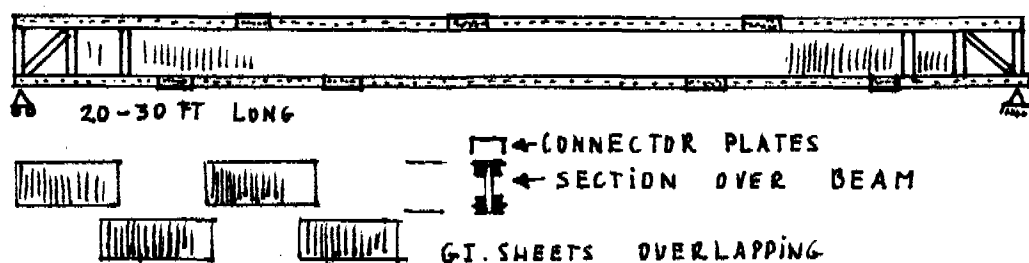

Composite Roof and Floor Beams (1.2.1 Refers)

BACIP composite beams are made with commonly available corrugated galvanised sheeting and commercially available wood sections. The composite beams are relatively stronger compared with solid wood beams and considering the amount of wood used.

- ◇ Materials used in the manufacturing of the composite beams are:
 - 26-gauge (0.42 mm) corrugated galvanised sheets measuring 42" in width. These require less cutting than the 32" or 36" wide sheets.
 - Wood sections measuring 2" x 4" or 1½" x 3". The wood sections depend on the span and expected load.
- ◇ The wooden members, with the galvanised sheet in-between, are nailed together with the beam being shaped with a slight upward curve (1:20).
- ◇ The size and length of the connector plates, and the number and type of nails per connector plate, are to be calculated on the basis of the expected momentum and forces in the beam.
- ◇ Connections between the lengthwise wooden pieces are made from painted 20-gauge (0.9 mm) metal flat sheets and galvanised nails.
- ◇ Compression connectors are different from stress connectors. In this manner short pieces of wood can be used to make a long beam.
- ◇ Larger trusses and smaller beams can be made based on the same principle. The higher the beam, the greater the resistance against a bending moment.
- ◇ For permanent constructions, the wood of the beam need to be treated with wood preservative and the metal pieces need to be painted with an anti-corrosive paint.
- ◇ The earthquake absorption factor of this beam or truss construction is very high, whereas the failure characteristic of this type of beam is very slow.
- ◇ The composite beam is about 1/3 of the weight of an ordinary wooden beam for the same strength and about 1/20 of the weight of an ordinary concrete beam with the same bearing capacity.

The composite beams in the BACIP office are two feet high. The free span of this 24 ft. long composite beam allows a 2000 kg load.

Bowstring Beams (1.2.2 Refers)

Shorter beams (purling) can also be made as composite beams using a single wood section for the compression area and stress wire. The engineering technology of the bow string, commonly used for making light traffic bridges in the Northern Areas, is applied for making this beam.

BACIP has adapted this design for local manufacturing by the village carpenters. The high tensile strength cable of the engineered bridges has been replaced with hot-dip galvanised 2.3 mm wires. In addition, special connector plates are been developed to suit simple manufacturing procedures.

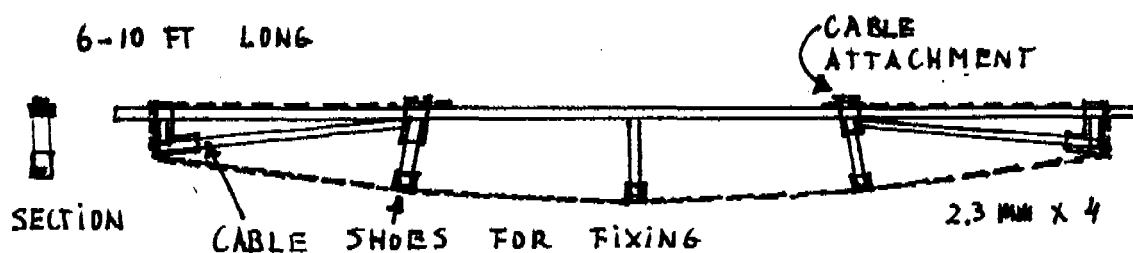

- ◆ The stress wire is made from several hot-dip galvanised wires, 2.3 mm thick and twisted into a bundle, taking care that all wires can develop full stress.
- ◆ The hot-dip galvanised wire has a tensile strength of 60,000 Psi (or 50 kg/mm²). Each wire takes 200 kg in the elastic zone and double the amount at breaking.
- ◆ To obtain the maximum forces, for every square inch of wood in the compression area of the beam, one 2.3 mm wire is required in the stress area. Flexion of the wood must be considered.
- ◆ Connections between the wood pieces are made from painted 20-gauge (0.9 mm) flat metal sheets and galvanised nails. The metal pieces are painted with an anti-corrosive paint.
- ◆ At the corners where the wire loops around the beam, special metal straps are applied for increased coherence between the wood members. A special wire guide is inserted at the extreme ends.
- ◆ BACIP has manufactured bow string beams 8 ft. in length which can carry 1000 kg. These bow string beams are either 1.5 ft. high (with a length of 8ft.) or 1 ft. high (with a length of 6 ft.).
- ◆ The roof area for an 8 ft. beam is 30 square feet, allowing 30 kg per square feet live roof weight.
- ◆ Preferably the wood of the beam should be treated with a wood preservative.
- ◆ The top wooden section (compression) can be composed of various short pieces, connected with compression connector plates. The number and type of nails per connector plate need to be calculated.

Roof Hatch Window (1.4.1 Refers)

Most of the traditional houses in the villages of the Northern Area have an 18-inch square-shaped opening in the middle of the ceiling of the main living quarter. The purpose of the opening is twofold: to allow the smoke produced by the open cooking/heating fire to escape and to let sunlight and fresh air into the room. However, while the roof opening does allow for the smoke to escape, it takes along with it the heat (warmth) from the room and lets in cold drafts and rain. In addition, smoke and cold air falling back into the room causes black soot to be deposited on the walls and ceiling. With the living quarters painted in black soot, the hole is ineffective in illuminating the area. All of which leads to extremely unhealthy and unpleasant living conditions, especially during the cold winter months.

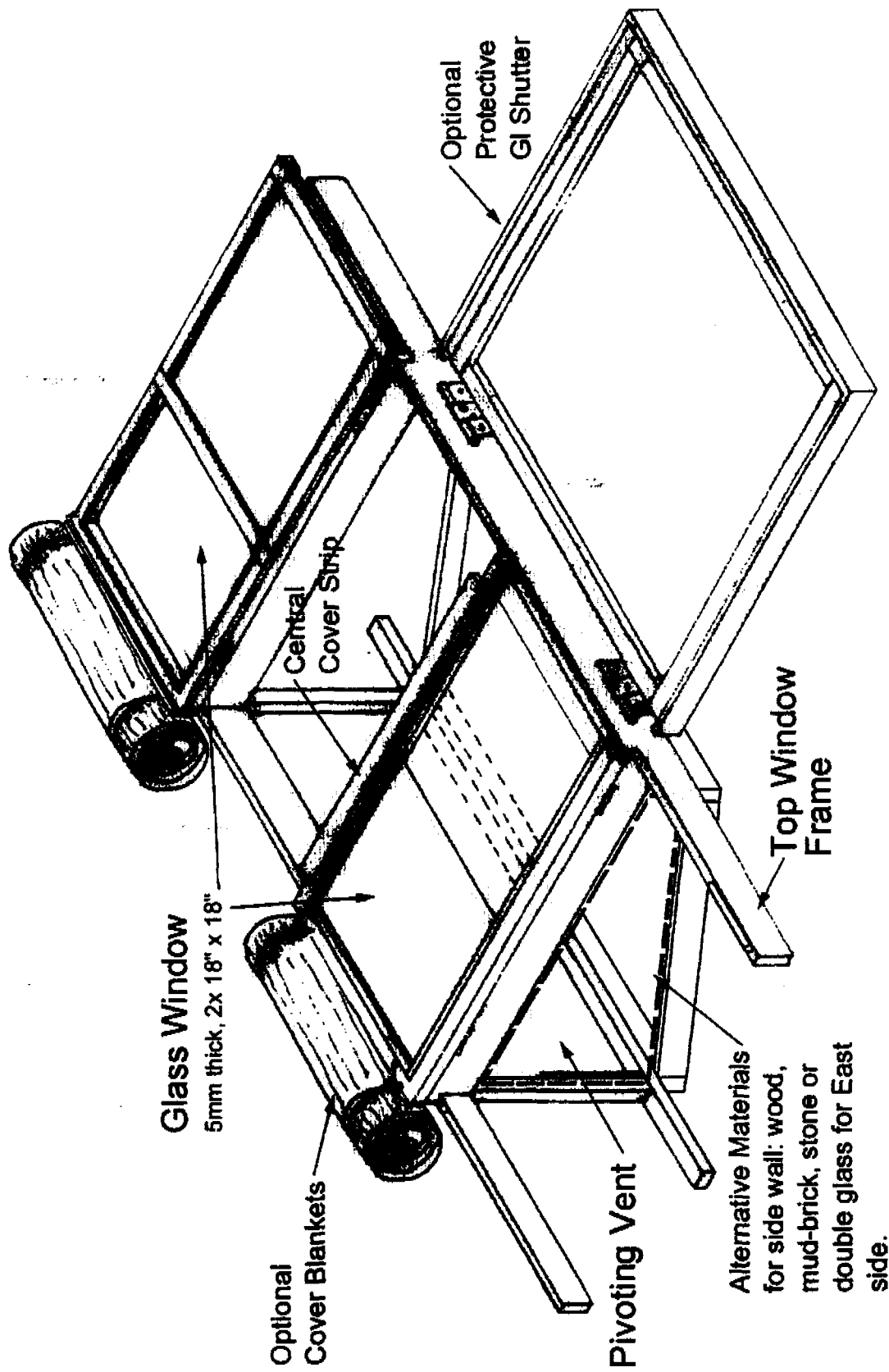

PAGE FROM THE ROOF HATCH WINDOW MANUFACTURING MANUAL

The BACIP roof hatch window does not disturb the overall traditional layout of the house, yet is efficient in terms of heat insulation and provides better illumination.

When we showed the drawings of a roof hatch window to a carpenter in Skardu, he commented: "This construction I remember from my grandfather's time." Actually we felt proud to have found one of the right solutions to the many problems.

To record the impact of this intervention, the villagers with the first models have been provided with a maximum-minimum thermometer and a registration table to record the temperature variance. It was found that the average temperature inside the room had improved by 6-8° Celsius, resulting in more comfort and a considerable reduction in firewood consumption. In one particular house only one quarter of the former year's quantity of firewood was used (four tractor loads a season). In autumn and spring no additional heating is required.

- ◇ The full-size BACIP roof hatch window has four glass panes (18" x 18"). Being four times as large as the traditional hole in the roof, it provides four times the amount of light.
- ◇ For optimal illumination and heat-generating effect, the roof hatch window should be placed facing south and the glass kept clean.
- ◇ In the vertical rear side of the roof hatch there is a pivoting shutter for ventilation which can be operated with a string from inside the house.
- ◇ The roof hatch window keeps the rain and snow out, avoids mixture of cold and warm air, and reduces smoke.
- ◇ The traditional 3-inch chimney pipe has been repositioned and fitted with a pivoting hood (*feri-feri*) to avoid back-draft.
- ◇ A standard BACIP blanket attached to the top of the roof hatch window frame can be rolled down to provide better insulation in the winter and protect the glass when the window is open.
- ◇ An optional single galvanised flat sheet shutter can be fitted to close over the top of the roof hatch with a single movement, providing additional insulation and protection at night.
- ◇ An optional wire-mesh screen can be placed to protect the glass. Children tend to throw stones into nearby trees to obtain fruits and cricket is actively played in villages.

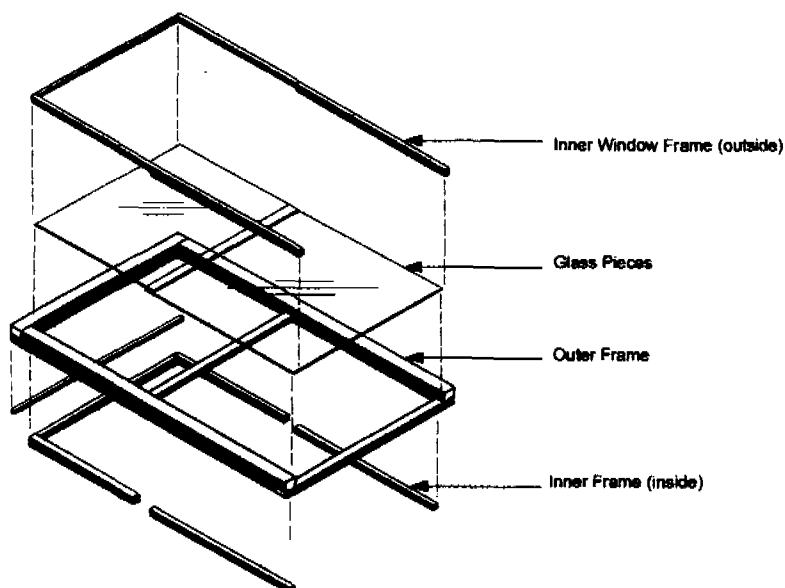

SAMPLE OF DETAILED DRAWING FROM THE BACIP ROOF HATCH WINDOW MANUAL

Dust-Free Ceilings (1.6 Refers)

Traditional roofs consisting of tree trunks, branches leaves, grass and soil are a constant source of dust falling from the ceiling. This dust is either the result of the deterioration of ceiling components through fungus and insect attack, or because small clay and sand particles filter down through the biomass of the roof construction. To stop this, some solutions were realised:

- ◆ A wooden lattice work (1" x 1½") is fixed to the ceiling. Panels of hardboard (2 ft. x 3 ft. or 4 ft. x 4 ft.) are then nailed onto the lattice work. Panels of 4 ft. x 8 ft. are too large to transport in the small trucks.
- ◆ The hardboard panels should be painted white before they are fitted, as painting upside down is cumbersome. A paint roller can be used for more efficient painting.
- ◆ The joints between the pieces are covered with wood strips (¾" x 1½"), also pre-painted.
- ◆ The white paint will dramatically increase the general light level in the room.
- ◆ The thermal insulation of the roof increases due to the additional air space between the suspended ceiling and the existing ceiling.

In one house the white ceiling made the room appear so much cleaner that this inspired the homeowner to whitewash the walls as well, enhancing the light level even more. The room was so bright and clean that the smoking stove was removed from the "upgraded" living room and placed in an adjoining room, making a new kitchen from the large store. The BACIP team is now trying to convince the owners to review the "new" kitchen on aspects of thermal insulation and light.

Roof Insulation (1.7 Refers)

During the summer time, corrugated galvanised iron roof sheets become extremely hot and the heat radiates into the house or school. The air space created by a false (suspended) ceiling does not function as an insulator because the strong heat radiation crosses the air space directly onto the suspended ceiling. Especially "modern" and urban houses suffer from the poor insulation characteristics of the GI roofs.

Under Corrugated Galvanised Iron (GI) Roof Sheets (1.7.1 Refers)

The BACIP roof insulation is designed in such a way that it can be easily installed under existing GI roof sheets. The insulation will stop the heat radiation under the GI sheets. Characteristics of this house improvement are:

- ◇ Possible to install under existing roofs by lifting the metal sheets and after insulating replacing them from the topside. The use of the house is not affected while the work is being undertaken. Additional nails (20% more) will be required as some will be damaged or lost.
- ◇ Requires low cost materials: reeds, straw, tall grass or wood-shavings; expanded metal (23-24 gauge); galvanised wire (2 mm) and plastic sheeting (0.1 mm).
- ◇ Dust-free house interior due to the use of plastic sheets over the expanded metal.
- ◇ Rat-proof due to the small mazes of the expanded metal (1/2"). Needs to be properly nailed on all sides.
- ◇ Lowers temperature under the roof by about 10° Celsius in summer.
- ◇ Insulates the building from heat loss, especially with strong winds in winter.

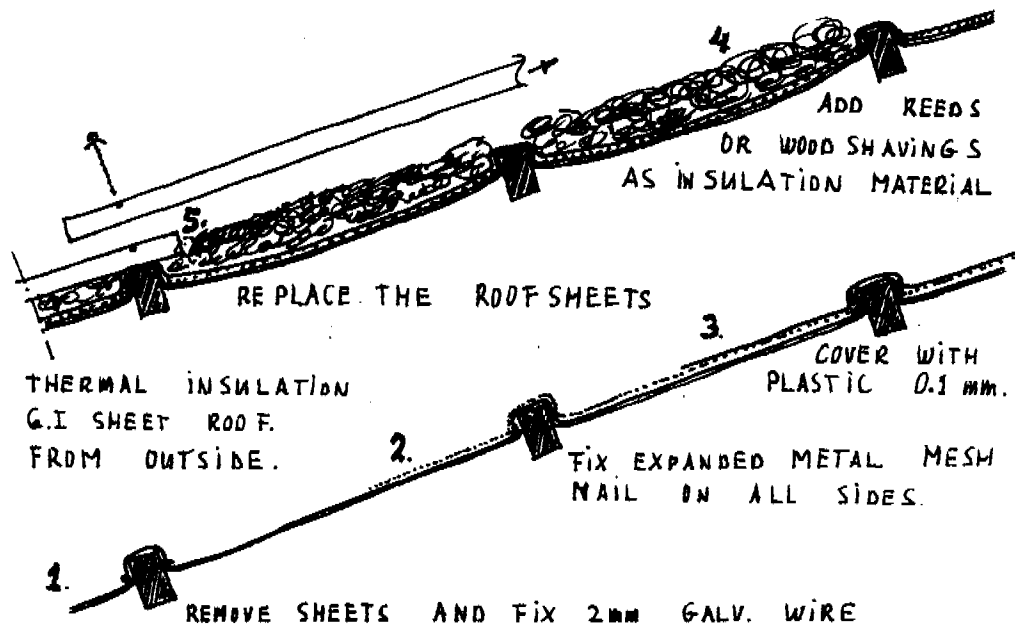

INSULATION CAN BE APPLIED UNDER AN EXISTING GI CORRUGATED ROOF

Over Corrugated Galvanised Iron (GI) Roof Sheets or Concrete (1.7.2 Refers)

Instead of lifting the GI sheets, it is possible to fix insulation on the outside of the GI sheets. For situations where GI sheets on the roof is undesirable, for example on cultural buildings, this roof insulation will give a "natural" look and insulate at the same time. This method of roof insulation is slightly more expensive than the above-mentioned type. The same insulation method can be used over existing concrete roofs.

The procedure is as follows:

- ◆ Special supports are nailed into the purling next to the existing roofing nails.
- ◆ The height of the nail supports determines the thickness of the insulation. A minimum of three inches of insulation material is recommended. For concrete roofs 4" steel nails need to be used. The steel nails should be hammered first through a one-inch wooden strip to avoid breaking the nail.
- ◆ The roof needs to be divided into working zones that can be plastered from the sides (3 ft.) as one cannot walk over the completed insulation or plastered surface.
- ◆ Insulation material, such as wood shavings or straw, is laid on the GI sheets (3" thick).
- ◆ A plastic sheet (0.1 mm) is placed over the insulation material.
- ◆ A fine maze (1/2") expanded metal wire-mesh (20-21 gauge) is nailed to the purling.
- ◆ The expanded metal is plastered with common cement mortar. At places where one needs to walk over the roof, a second layer of expanded metal can be applied and plastered again.
- ◆ To prevent water evaporation caused by the sun, the freshly plastered roof should be covered with wetted BACIP blankets.
- ◆ If it is a flat roof, once the roof has hardened after a few days, one can walk over the surface provided wooden planks have been laid.
- ◆ The insulation lowers the temperature on the inside roof between 5-10° Celsius. It also insulates the building from heat-loss in winter.

Stoves for Cooking and Heating (2.1 Refers)

Present Situation

Most of the villagers use a round, sheet-steel cooking stove (*bukhari*) placed directly on the soil floor of the house. These *bukhari*'s are considered low-cost with prices ranging between Rs. 1200 (20 Euro) and Rs. 2000 (35 Euro), equivalent to one month unskilled labour.

Several years ago this round metal *bukhari* cooking stove was introduced by AKPBSP. This was a great improvement in comparison with an open fire in the middle of the traditional room. As time went on, these *bukhari*'s began to be manufactured using thinner recycled sheet metal to reduce the cost, resulting in less durability. The fire produced in these *bukhari*'s was of high heat intensity, but extinguished rapidly. As a room heater, the thin metal sheet *bukhari* proved advantageous for it quickly heated up the interior. No separate room heating device was therefore required in the living area; the one *bukhari* functioned as both a cooking and heating device.



IMPROVED TRADITIONAL STOVE WITH FIXED CHAPATTI CONCAVE PLATE

Identified Problems

- ◇ The common practice for igniting the *bukhari* is via the wide (15") cooking hole, allowing large clouds of smoke to escape from the stove into the room.
- ◇ Small pieces of wood are required for fuelling the stove, obliging women to spend extra time on wood chopping.
- ◇ In the summer the *bukhari*'s or other stoves are usually not used inside the house as it makes the room too hot. Instead an outside "three-stone" open fire is used. The three-stone open hearth consumes large amounts of firewood as compared with the enclosed *bukhari* stove.
- ◇ Due to the thin sheet, the durability is rather limited and the stove does not last longer than 3-4 years.
- ◇ It is difficult to install a water heating device in the present *bukhari*.
- ◇ Thick steel plate is not commonly available in the villages.
- ◇ Many stoves and chimneys suffer from back-draft because the chimney only protrudes a short distance above the top of the roof.

Alternative Designs

The first alternative designs focused on energy saving, using an insulating stabilised soil construction for the sides of the stove. However, the energy saving factor proved unsatisfactory in the winter when extra heat radiation is required. The soil construction took too long to heat up the room, required too much work to build and was rejected as being non-fashionable. The villagers insisted on all metal stove designs. The number of all-metal designs gradually increased as many clients wanted something wider or smaller, longer or shorter. Various options are now available, such as having the front top of the stove concave for making chapatti's.

Top Plate Stove. The BACIP top-plate stove (2.1.1) is the cheapest of the line, consisting of an 18-gauge (1.2 mm) thick steel top cooking plate. The cooking plate, which may last for 8-10 years, is placed on top of a line of interlocking burned clay bricks. The stove has a reduced side heat radiation due to the insulating effect of the burned bricks and thus saves on firewood. This makes the stove particularly interesting for summer use. Thus the advantages of this model are its low cost (only the top plate), low wood consumption, ease of transport and durability. The top plate can also be made from 16-gauge (1.5 mm) steel plate. The top plate can be easily transferred between an outside summer cooking stove and the inside winter cooking/heating stove, or stored for winter.

Metal Sides Stove. This slimmer type of stove has the advantage of producing rapid heat radiation once the fire is lit, a characteristic which appeals to most of the clients. The metal sides stove is more expensive than the top plate stove (requires more steel). Being made of thick 18-gauge steel plate, this stove is also durable. It is easy to manufacture and comes in four different designs.

Metal Sides Stove, Insulated. One of the design options is a wider stove, allowing room for a line of burned clay tiles of one inch thickness. These tiles are placed inside the stove between the water pipe and exterior metal sides. These clay tiles block the heat from wood fire from radiating through the sides of the stove. The advantage is that in the summer, when no heat radiation is required, the insulated stove consumes less firewood.

All Metal Stove on Legs. This stove is more costly than the type with only metal sides and is preferred by people who wish to move the stove occasionally, or have wood or cement floors.

Sawdust or Chaff Stove. The sawdust stove first burns on gas from the biomass. After the sawdust is de-gasified, the remaining charcoal dust is then mixed with 10% wet clay and compacted into perforated briquettes. After the briquettes are sun-dried, they can be burned as charcoal in the same oven. A compactor is part of the equipment set.

In addition to the new line of stove designs, a number of additional fittings and attachments can be obtained to improve the performance:

Feri-feri. Meaning "crazy" in Urdu, this free turning chimney cover is placed vertically in the top of an existing (3") chimney pipe to avoid back-draft. It twirls around like crazy when the wind comes from different directions. The fan allows the smoke to exhaust in any wind direction and improves the draft.

Chimney Roof Passage. The square chimney roof passage is designed for traditional soil roofs and is always applied with the installation of the roof hatch window as the chimney must be repositioned. It creates a waterproof chimney passage and reduces the risk of the roof catching fire in case of a burning chimney. It also helps to ventilate the room.

Top Oven. This is a double-walled container to be placed on top of the *bukhari* to create an oven. The design was commonly used in Europe in the beginning of the 20th century to conserve heat.

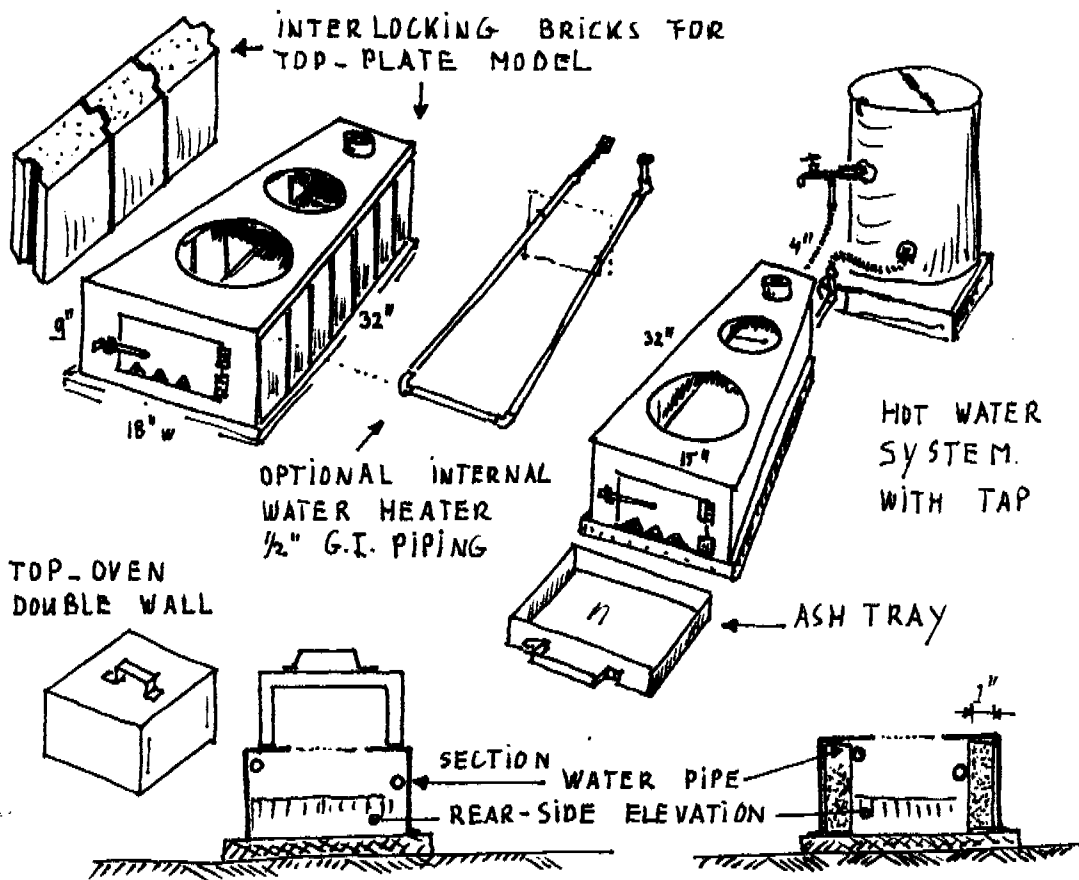

WIDE STOVE WITH INFILL TILES FOR SUMMER USE.

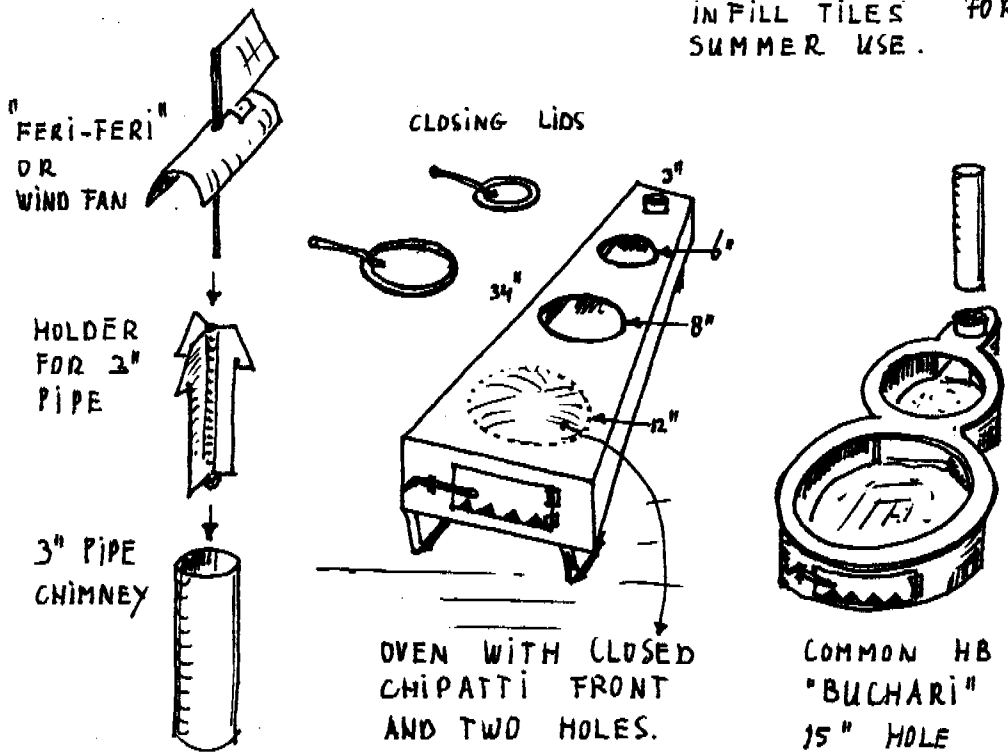

Water Heating Facility, Stove Attachment (2.2). Warm water used for cooking, dish washing and personal hygiene is regularly required. Boiling water is required for cooking purposes, whereas warm water is desired for other uses. Existing solutions are based on metal sheet containers built in or on the stove, or around the chimney outlet, and fitted with a tap. These solutions will eventually rust and leak. In addition, the volume of the systems is rather limited and they are inflexible once installed.

The BACIP water heater is based on three separate components, each of which can be designed to the user's needs and are easily connected. The system can be installed in almost all existing stoves.

- ◆ Inside the stove a 1/2" galvanised water pipe is fitted (in a slope).
- ◆ The GI pipes extend out the back of the stove; the inlet water pipe low, the outlet high.
- ◆ Behind the stove a plastic water barrel is placed (75-130-200 litre) on a low stand.
- ◆ The stand is at least as high as the height of the stove and can be cemented.
- ◆ The barrel is fitted at a low position with a 3/4" GI outlet and a 3/4" GI inlet in the middle.
- ◆ The outlet is fitted with a 3/4"- 1/2" reducer and a security valve.
- ◆ The inlet is fitted with a 3/4"- 1/2" reducer T-junction and a tap.
- ◆ Between the barrel and the stove two flexible metal hand shower extensions are fitted.
- ◆ When the fire is burning, boiling water can be taken from the tap for cooking.

Water Heating Facility for Laundry (2.3). In winter the women wash their clothes in freezing cold glacier water. This water heating facility for laundry washing purposes follows the principle of the top plate stove and a chimney. The design uses the tub of a standard wheelbarrow (80 litres) made from 20-gauge (0.9 mm) galvanised sheet metal with a reinforced rim. The unattached tub can be either placed in the yard or carried to/from the riverside. The tub can be used in a single position or in a series so that several villagers can wash their laundry as a group. A village laundry unit consisting of several tubs can eventually be developed.



THE DESIGN OF THE LAUNDRY TUB WAS BASED ON THE FIRST STOVE DESIGNS.
THE USE OF A TUB REQUIRES A CHANGE IN THE LAUNDRY TECHNIQUE
AS THE WOMEN ARE USED TO WASHING LAUNDRY IN RUNNING RIVER WATER.

Ventilation Holes in Existing Walls (2.7). In many houses ventilation openings do not exist, but are essential to improve air ventilation and reduce humidity caused by exhalation. High levels of humidity exist inside traditional houses due to roof leakage, water infiltration into the walls and condensation of the exhaled air onto the cold walls.

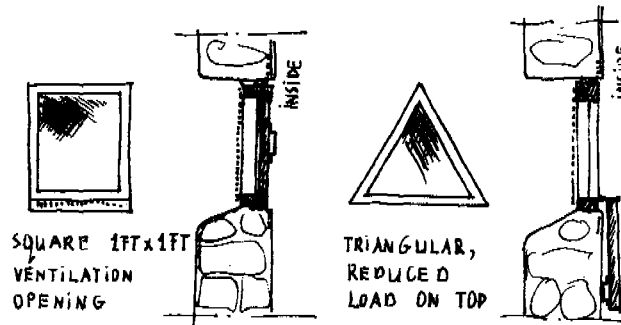

- ◇ The designed ventilation opening can be either square or triangular shaped.
- ◇ The opening is fitted with a small wooden door and fly screen (nylon or metal).
- ◇ The triangular design has been made to distribute the load from the wall above the opening sideways when no other reinforcement can be inserted (existing walls).
- ◇ The frame has a strip of wire-mesh on the side to anchor it into the wall.
- ◇ The ventilation opening should be reachable height so it can be easily opened and closed.
- ◇ The door can have a light locking device (rolls, magnet), a 2" dead-bolt and a handle.

Improved Sun-Side Window (3.1 Refers)

With the exposure to "modern" architecture, an increasing number of villagers are constructing new houses not only with more windows, but windows having larger apertures with bigger glass panes and indiscriminately oriented in any direction. In the cold and windy situation of the region, these larger window designs act as very poor insulators and cause the rooms to rapidly cool down. Moreover, these windows are fitted with wire-mesh fly screens in the sun direction on the exterior face of the window. The outside (dirty/dusty) fly mesh obstructs more than 60% of the sunlight and thus hinders heat intake. The removal of the fly screen alone increases the inside room temperature by 4-5° Celsius.



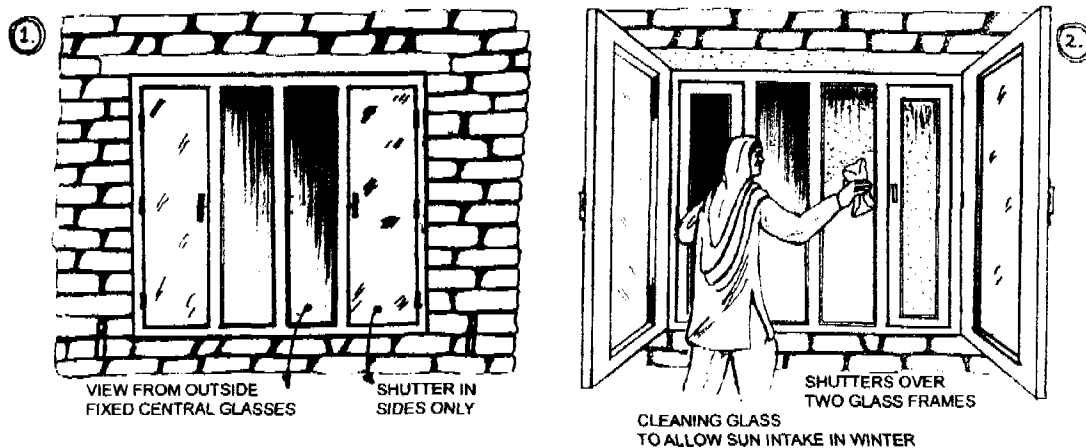

When the large fly screens were removed from the south-side windows in the corridors of the BACIP office, it became the warmest place in the entire building. Without heating the average temperature raised by 12° Celsius during the daytime. The effect of the greenhouse principle is known, but not applied in the case of the sun-side windows.

The proposed window improvements require little modification of the existing window frame and can be installed on top of the existing frame. Attention has been given to the fact that the improved window can serve for both summer and winter conditions.

Once the inside space has received optimum sun, the residents are to close the second window or outside shutters. The second glass frames or shutters will create an insulating air space and maintain the thermal comfort at a higher level than achieved with only single glass.

The BACIP sun-side window has the following features:

- a) It is either a double-glass window or a shuttered window.
- b) The window is fitted with detachable fly screen frames of white nylon or metal mesh. In summer the fly screen not only prevents the flies from entering the open window, but it reflects the sun, allowing less heat to enter the room. The detachable fly screen should be removed for the winter to allow optimum sun intake. Pin hinges are used for easy removal and fitting.
- c) A new, larger glass window is fitted on the inside of the exterior wooden window frame. It is designed with a thinner wood section for maximum light intake.
- d) In windy areas the double-glass window or additional shutter reduces the forced ventilation through the window opening, especially if the carpentry work is of poor quality.
- e) Exterior shutters should be closed at sunset. Wooden shutter frames are covered with flat 28-gauge (0.37 mm) galvanised sheets that are half an inch smaller than the frame and screwed into place. This allows for precise adjustment of the shutter frame into the window frame.
- f) Galvanised 4" high hinges have been manufactured so the open windows and shutters can lie flat against the outside walls of the house, held with BACIP-designed catches.
- g) Shutters can be fitted with pin hinges to allow easy removal for summer storage.
- h) The inside windows can be opened in such a way that sunlight transmission can occur through single glass, providing minimal light obstruction.
- i) The windows are fitted in such a way to allow easy access to all glass surfaces. The glass should be cleaned regularly for optimum light transmission.

One recipient of a model shuttered window was very happy with the improvement and commented, "Yes, the house is much warmer, but also darker". Upon investigating, the BACIP team discovered that he had **not** opened the shutter for weeks. Following a renewed briefing, the house became even warmer after the homeowner opened the shutters during the sunny daylight hours.

Improved Shadow-Side Window (3.2 Refers)

The shadow-side window is preferably a double-glass window resolving the same problems as indicated above under the description of the sun-side window.

Some of the differences with the sun-side window are:

- ◆ The shutter of the sun-side window is used to allow the sunlight to penetrate into the house through a single glass sheet. That is not the case with the shaded side of the house.
- ◆ The fly screen does not have to be removable and can stay in place year-round.
- ◆ The glass surface does not have to be increased to catch more sunlight.
- ◆ It is not essential to keep the window clean in winter as the window receives no direct sunlight.
- ◆ The curtained window (3.3 refers) can be inside the thick walls, saving curtain material, additional side closures and cost.

The other aspects of the sun-side window apply to the shadow-side window. The above implies that converting a shadow-side window into a double-glass window is easier and less costly than making a sun-side window. In both cases the additional curtained window will again increase the insulation effect (see below).



Curtained Window (3.3 Refers)

Hanging a window curtain is an effective measure for keeping warmth inside the room. In some traditional houses people have also placed a curtain by the doors to stop the draft. A curtain creates an insulating air layer between it and the glass. Two curtain designs have been made, one for recessed windows in thick stone walls having a windowsill and one for placing in front of the window.

Characteristics of the curtains are:

- ◇ A curtain that is hung inside the recessed window opening needs to be fitted closely against the lintel, walls and windowsill on all four sides.
- ◇ It is important that a sun-side window curtain can be fully opened during the daytime to allow optimal sunlight intake. To achieve this the curtain needs to be placed on the wall and extend beyond the window.
- ◇ The front curtain should hang down to the floor or rest on the windowsill. The top of the curtain needs to be covered to avoid air circulation.
- ◇ Properly curtained windows are one of the least expensive window insulators, provided they hang neatly against the wall and are opened and closed in a timely manner.

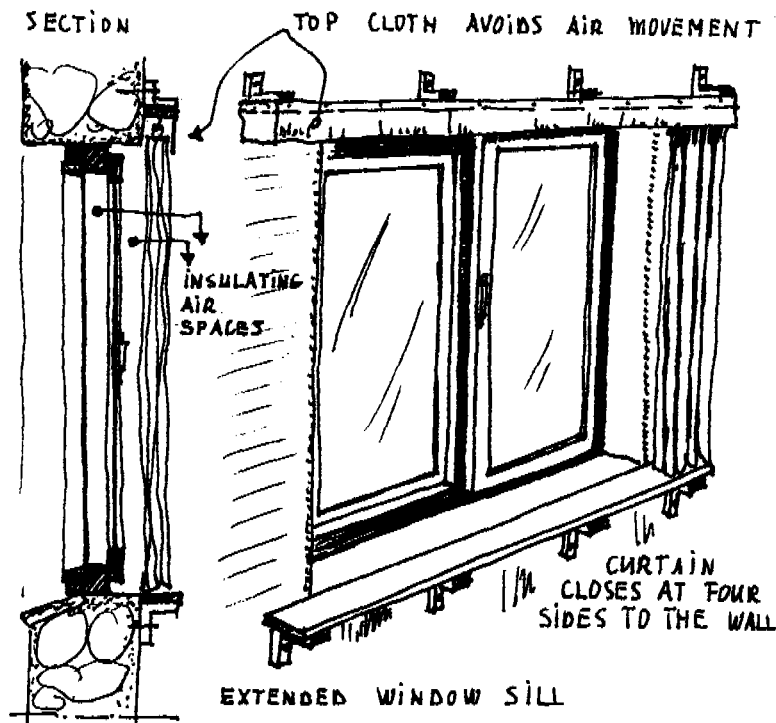

Damp-Proofing Foundations (4.6 Refers)

The following two situations appear in most of the villages:

- A. The surface water of small water channels passing alongside houses filtrates into the ground and is absorbed by foundation walls. This is even more pronounced with cement block walls and cement masoned constructions as these are highly hygroscopic.
- B. Houses built on slopes or otherwise dug into the ground have water infiltration descending from the slope. This type of water infiltration is more pronounced in loose stone walls as no barriers exist to block the water. In the case of clay soils, humidity will be persistent.

In one "dug-in" house the lower half of the rear wall of the main traditional room was constantly wet and growing mould. Upon investigating the outside of that wall, it turned out to be the open-air toilet corner of some neighbours. In addition it was the dead end (collection point) of surface rain water. Apparently the house owner could not buy the three square meters of land behind his living room.

To rectify the problem, the roof drainage points were relocated, an elevation was made in the road to prevent surface water from collecting in the "toilet area", the wet wall was dug out and a plastic sheeting was placed against the foundation. As for the "toilet area" itself, the neighbours were advised to go elsewhere for their daily needs.

The remedy is rather simple, but does involve some digging and the application of plastic sheeting along the outside wall of the foundation. Care must be taken that no water pockets result where water can accumulate and eventually drain towards the foundation walls.

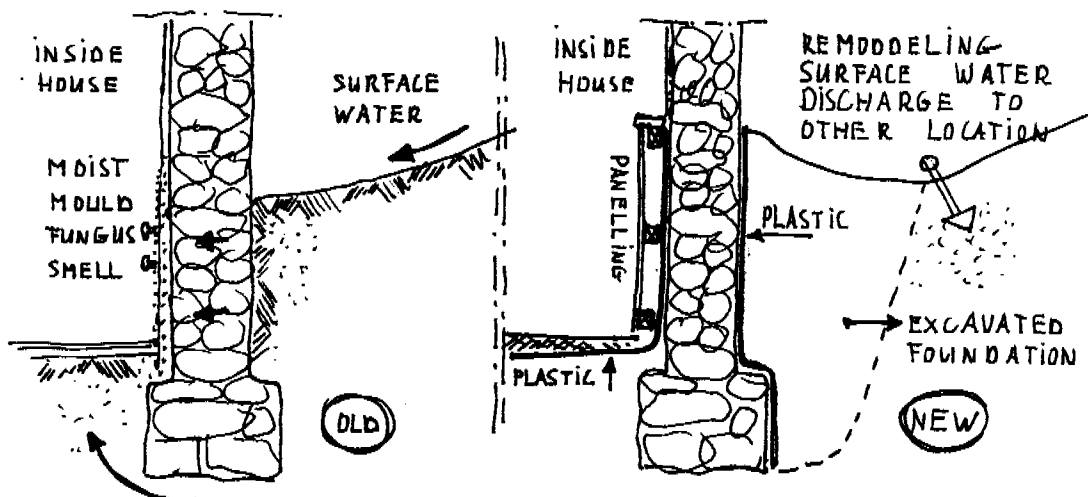

Galvanised Wire-Mesh Wall Reinforcement (5.1 Refers)

Traditional houses in the Northern Areas were mainly constructed in dry stone with wooden lateral reinforcements. However, durable wood that can be used in outside constructions is scarce and unaffordable for villagers. In the absence of appropriate alternatives, the villagers are constructing walls without any reinforcement. The situation makes all such units highly vulnerable to earthquake jolts and does not allow for the building of two- or three-storey houses.

Although binding stone walls with cement mortar is the best measurement for making stone masonry earthquake resistant, the disadvantages of using mortar in the remote villages outweigh the advantages:

- Cement is costly by itself.
- Cement is heavy and difficult to carry and therefore additionally expensive in transport.
- For loose stone construction large quantities of mortar are required (30% of the wall volume).
- Reasonable quality of sand is required for the cement mortar. This sand can only be collected in some riverbeds, usually not close to the higher mountain villages.

These disadvantages are compounded when making reinforced concrete:

- Concrete requires wooden form work.
- Steel reinforcement bars are needed that are difficult to shape in the correct manner.
- Concrete requires strong cement mortar to protect the bars from corrosion.
- Curing of the concrete is required in warm weather and needs to be protected in cold weather.

**Traditional Reinforcement
From Wood**

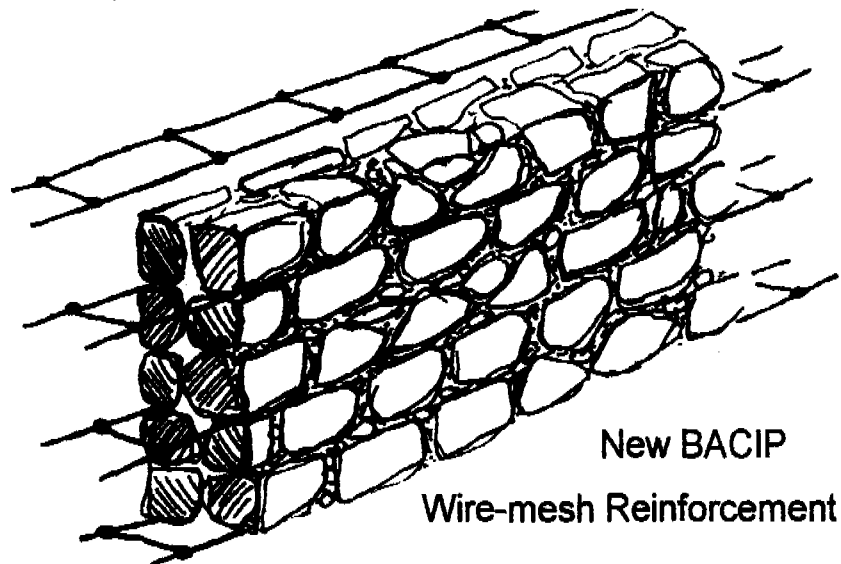
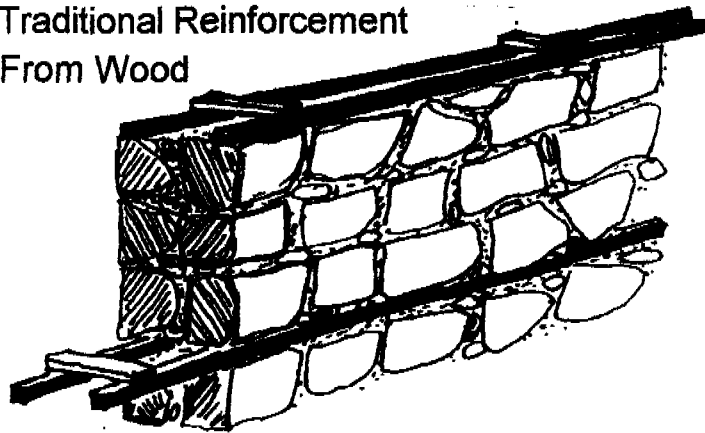

**New BACIP
Wire-mesh Reinforcement**

New houses can be effectively strengthened with reinforced concrete (heavy and costly) or with **BACIP galvanised iron wire-mesh wall reinforcement** (light and low cost). The BACIP galvanised iron wire-mesh strips for wall reinforcement have been designed for manufacturing in any mountain village. The galvanised wire-mesh can be used in natural stone wall masonry, cement block masonry and soil block masonry (adobes).

The wire-mesh is given the shape of a long ladder (the dimension of the wire-mesh varies depending on the wall dimensions) and can be produced locally. The production of different pieces of the wire-mesh has been made possible with the help of simple, locally designed hand-operated BACIP wire-mesh equipment. The wire-mesh is applied horizontally between the courses of stones, cement or mud blocks. The wire-mesh will strengthen the two-stone masoned walls by linking the two outer faces of the wall and reinforcing the wall in the length direction. The same wire-mesh could be used to create lintels over the door and window openings and tie-beams to resist the shear stresses within the walls.

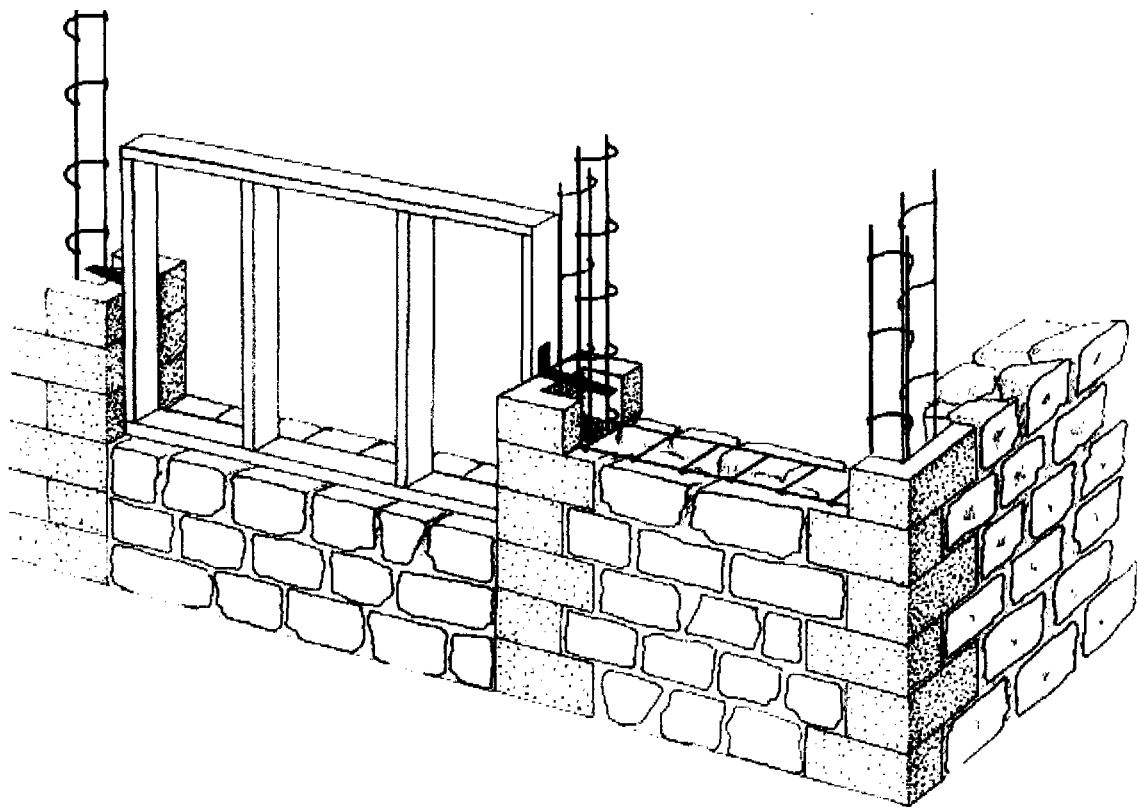

AROUND WINDOW AND DOOR FRAMES, C-BLOCKS ARE USED.
THE WIRE REINFORCEMENT IS EXTENDED VERTICALLY ALONGSIDE THE WINDOW AND DOOR FRAMES.
SEVERAL VERTICAL STRIPS TOGETHER MAKE THE SHEAR WALL AND PIER REINFORCEMENT.

The following two detailed BACIP publications give more information about the technology and the equipment used:

- *GALVANISED WIRE-MESH WALL REINFORCEMENT METHODOLOGY*
Application of the BACIP Wire-Mesh Reinforcement (December 1999)
- *THE DEVELOPMENT OF THE WIRE-MESH KNOTTING EQUIPMENT*
(December 1999)

The BACIP-designed wire-mesh wall reinforcement:

- Increases shear stress resistance and structural coherence of the walls.
- Creates horizontal lateral reinforcement inside the walls. The thicker the wall the wider the exterior reinforcement wires will be placed, thus allowing greater momentum and resistance against lateral force. This reinforcement compensates largely for the greater weight of the thicker wall.
- Provides a full bonding between the two faces of a two-stone dry stone masonry wall and replaces the function of many tie or key stones.
- Is cost-saving as less cement needs to be used in the mortar than would otherwise be required to protect common steel bars against corrosion. The hot-dip galvanisation is a protection against corrosion. Therefore the wires can also be used in adobe constructions.
- Can be realised in traditional stone architecture.
- Can be knotted in different widths, thus accommodating any width of wall.
- Provides connection in the corners and between the wall sections.
- Lends itself to the possibility of having a well distributed reinforcement in every layer of the stone or block masonry. Eight single galvanised reinforcement wires of 2.3 mm (4.1 mm^2) together have more strength than one $\frac{1}{4}$ " (6 mm, 28.2 mm^2) common reinforcement bar. Eight wires can be distributed over four layers (two wires per layer). This provides a more even distribution of the reinforcement in the wall and better relates to the weight of the wall (= force of the earthquake).
- The equipment to make the knots in the wires has been developed in such a way that it is easy to transport in small units. This allows transport up into the (remote) mountain villages.
- The manufacturing method of the wire is very simple and can be learned in a single day by unskilled labourers.



ENOUGH WIRE FOR A TWO-STOREY HOUSE – 140 KG

Thermal Insulation Walls (5.6 Refers)

Improperly insulated and humid outside walls of massive weight are the two major causes of heat loss from the living quarters. In cold areas the centrally located traditional room is protected by peripheral storage rooms and entrance areas. In more "modern" houses these peripheral rooms are omitted. In addition cement mortar or cement blocks in mortar are used, causing very high heat transmission and rapidly cooling the interiors.

BACIP found several situations where a villager had built a "modern" new house from cement blocks. For the winter the family would move back into their old (half collapsed) traditional house as it was impossible to get the new house warm, not even with an extra lorry of firewood. However, with the old traditional house remaining empty all summer and devoid of a fire, it began to rot away even further from the humidity and fungus. On top of that, in the summer the new house was suffocating hot.

When BACIP tried to explain how the new house could be effectively insulated, they complained bitterly saying that they had already spent all their money on the new construction.

The above illustrates the importance of good information about construction techniques for people who wish to build a house.

The 18-20" traditional stone (and mud) constructions have a low heat transmission due to little contact between the stones inside the walls. However, these walls are unsafe with respect to earthquakes. Thick interior mud plaster found in old houses insulates walls against heat loss. In Hunza and Baltistan residents use colourful cloths against the mud surface to prevent the plaster from rubbing off. The loosely attached cloth creates an air space between the wall and cloth, thus providing additional insulation. In the very cold areas of Baltistan, woven panels from willow branches are covered with mud plaster to create lightweight inside walls which have good thermal insulation properties.

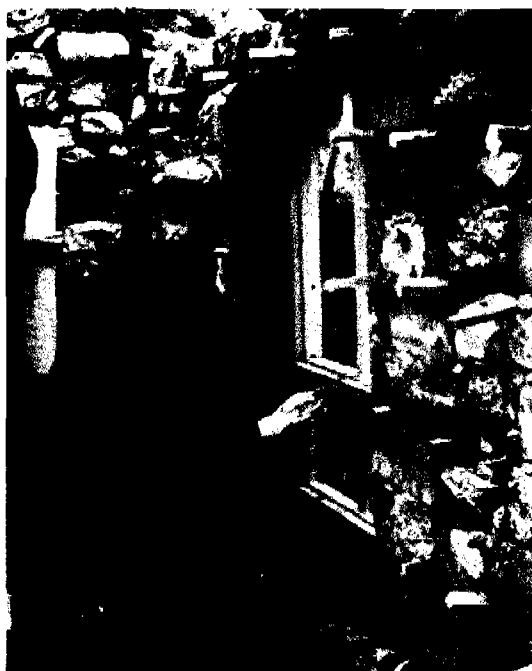

PEGS ARE USED TO FIX WIRE-MESH FOR AN INSULATING CAVITY WALL CONSTRUCTION

Good solutions can be found for interior wall insulation. Their application depends on the availability of materials and the financing capacity of the client. Wall insulation must be placed on the inside of the exterior walls and be as light as possible, not only to keep its own heat storage capacity low, but also to keep the earthquake risk low (weight related). Following are some possibilities:

- Free standing mats (3 ft. x 4 ft.) woven from willow branches are fixed against the walls on wooden strips. A two-inch air space is kept between the mat and the wall. For additional adherence, an open wire-mesh can be fixed before plastering. Soil-cement plaster is used for finishing.
- Wooden pegs of six inches in length are hammered into existing walls or masoned into new walls, protruding two or three inches. Wood strips are placed on the pegs, then plastic foil, followed by expanded metal and finished with a soil-cement plaster.
 - Plastic foil (0.1 mm) is fitted directly on the pegs behind the wire-mesh to avoid leakage of the wet plaster into the cavity. It also keeps the plaster wet to allow hardening. Once dry, condensation inside this wall is unlikely to occur because the plastic damp-proofing is directly under the thin plaster surface and on the warm side of the construction.
 - The expanded metal is of 24-26 gauge (0.2 mm) with openings of half an inch. The metal mesh is first primed with cement slurry to avoid corrosion. For finishing a soil-cement plaster is applied (mixture 1:10).
 - For schools and other walls that require increased resistance, a double layer of plastered expanded metal can be applied to the lower three feet of the wall. At table height a wooden plank can be fixed.
- Wooden strips (2") are fixed on the wall, then plastic applied and followed by hard board (or plywood) sheets. This construction is very lightweight and quick to apply, but costs more in materials.
- Cavity wall construction can be made with thin cement blocks, anchored to the main wall.
- Three-foot high reed mats (*chatai*) can be placed against the inside of the wall. This can be done as an addition to all of the above solutions.

For control purposes, each house owner with a model improvement is equipped with a maximum-minimum thermometer and a log sheet to document the temperatures. In addition, wood consumption is measured by the families.

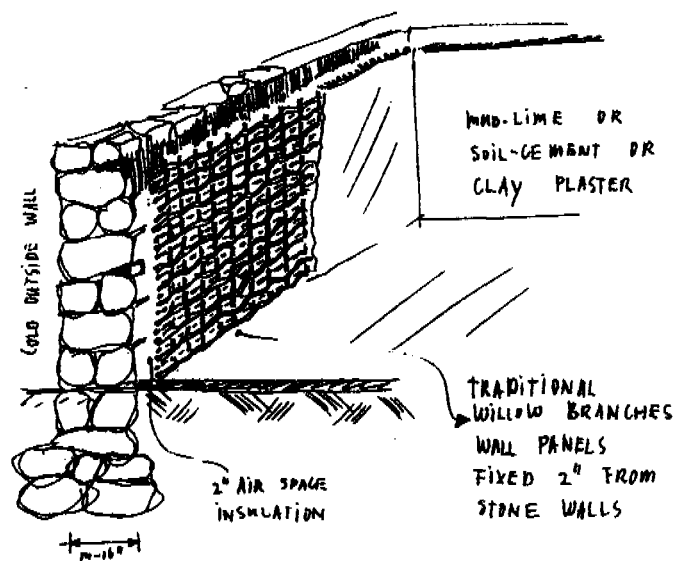

LOCALLY AVAILABLE MATS MADE FROM WILLOW BRANCHES CAN BE USED TO REALISE A LOW-COST, HIGH QUALITY WALL INSULATION

Storage for Bedding (6.6.1 Refers)

During village consultations, the local women identified the need for bedding storage as a problem. The bedding (thick cotton-filled quilts, comforters and blankets) are each morning folded and piled on the floor in some corner of the room. Lying against the cold stone walls and due to lack of ventilation, they become damp and musty. This consumes not only floor space but is rather unhygienic. Most bedding is dirty, humid, mite and insect infested, and a source of fungus. On sunny days it is carried outside and draped over rocks or thorn bushes to dry.

The present design resolves all of the above problems:

- ◇ Cleaner, ventilated bedding.
- ◇ More available floor space. It can be installed in the room or on the veranda.
- ◇ Collapsible design, saving space and making it easy to transport.
- ◇ Design manuals for self-manufacturing by village craftsmen.
- ◇ Design versions in either three or four shelves to accommodate different room heights.
- ◇ The rack having four shelves can store more than eight bedding quilts (over 200 kg).
- ◇ The design can be supplied in natural, varnished or colour painted to suit individual preferences.
- ◇ The house owner can add a cover curtain made from cloth to protect the bedding from dust.

The bedding storage rack consists of a wooden frame that is fixed to the wall by means of vertical supports. A 100 micron (0.1 mm) plastic sheet placed first against the wall prevents the transmission of dampness from the wall. Three or four collapsible horizontal wooden frames with strings support the bedding goods.

Villager: “ The bedding is much drier now and it does not smell.”
BACIP: “How did it smell before?”
Villager: “Well, the small children often pee in bed at night, but now that the quilts dries out on the bedding rack, it does not smell so much.”
BACIP: “OK”



Storage Containers for Food

(6.6.3 Refers)

The agricultural communities in the Northern Areas depend largely on their own food stock during the entire year, especially in the winter period. Immediately after the harvest (June-August) the rat population increases and eat a considerable portion of the food when not properly stored.

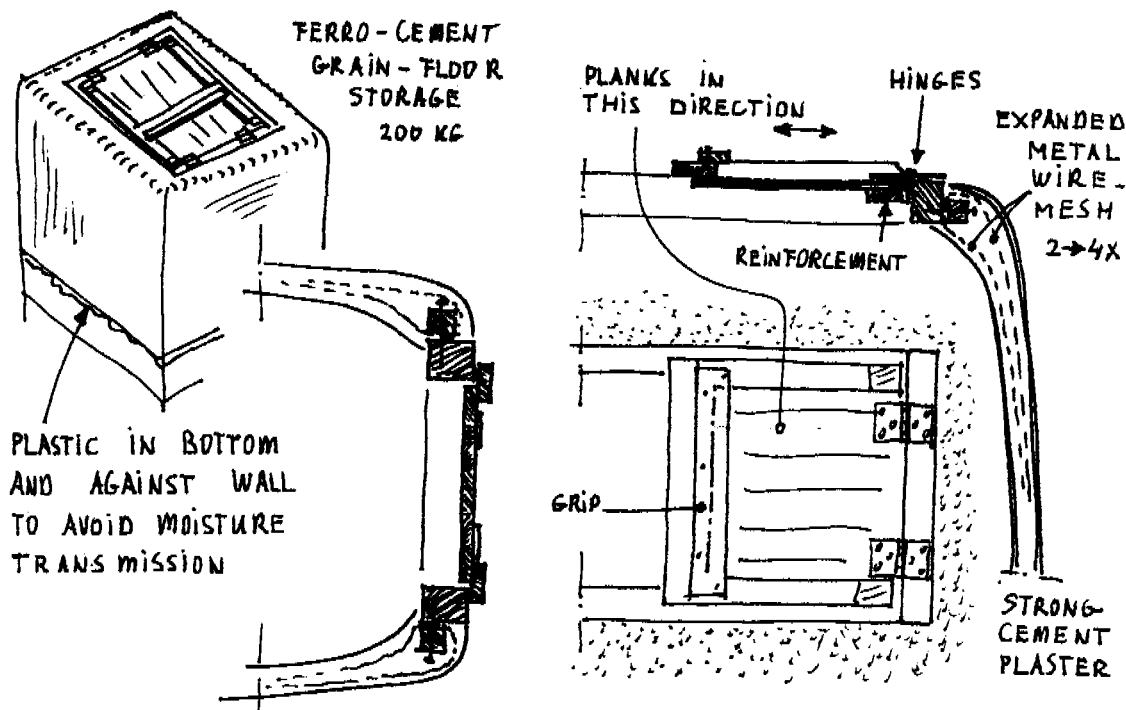

- ◆ BACIP-designed storage containers are rat-proof due to the applied wire-mesh or expanded metal on the inside of the container wall.
- ◆ The container is placed on plastic to avoid humidity rising from the foundation or coming through the wall.
- ◆ The inside is cement plastered (mixture 1:3).
- ◆ The outside of this unit is plastered and whitewashed.
- ◆ A large, high unit is made for grain-storage, built of stones and with expanded metal inside. There is an opening on the side for tapping grain. The floor inside the storage is inclined so the grain flows towards the front opening.
- ◆ Thin wall containers are made from ferro-cement. Three layers of wire-mesh are used as a self-supporting frame. This container is also waterproof. Almost any size food storage and water tank can be made following this ferro-cement principle.

BACIP: "What do you think of the new grain container?"

Villager: "I will tell you next year when I reach to the bottom of the container. If the grain is still good and not spoiled by mildew, then I will be happy with the storage container."

The answer indicates that for the acceptance of some improvements two whole seasons are required to get locally initiated replication.

Rat Traps (6.6.5 Refers)

During field visits of Baltistan and Chitral regions, it was found that many of the villages were swamped by rats and mice. Later, it was discovered that the problem is prevalent in almost all the villages of the Northern Areas.

The rats thrive on the grain and other food items stored by the villagers. It was analysed that the problem lies with the poorly constructed and maintained storage spaces. The walls and roofs of the storage rooms are mostly constructed in dry stone masonry and have a number of holes, making easy entrances for all such animals. Poor illumination and ventilation, coupled with easy access, provides a conducive environment for these rats to feast on the "goodies". According to a rough estimate, every year 20-30% of the total grain stored is being consumed by these animals, causing a great loss to the already suffering villagers. The situation is worsened with the potential threat of other related rat-carried diseases as well.

The option of using rat traps was hardly applied due to the fact that good quality rat traps were not available in these remote villages and, if available, were expensive.

The situation called for both short- and long-term solutions. Among the long-term solutions BACIP proposed to improve the storage containers and undertake re-planning of the otherwise dark and dirty storage rooms. Simultaneously, BACIP proposed a short-term solution to reduce drastically the rat population by supplying good quality, cheap rat traps.

During a village meeting, after the Rs. 10 rat traps were shown, one villager grabbed the microphone and told the community in the local language that "this was a good quality trap, better than the one in the city and only half the price." Within half an hour 60 rat traps were sold in the village (consisting of only 100 households).

The rat trap story tells us several things:

- Simple low-cost solutions can be found for great problems.
- When many people apply the solution, massive savings can be achieved.
- When a few intelligent villagers are convinced, they will actually promote the idea or product and other villagers will follow.
- People look at the combination of quality and price.
- By buying and marketing the article in quantity, up to 50% cost reduction can be achieved.
- The solution must be economically and/or socially appealing to the individual who has to pay for it.



H-A Frame Chairs (6.7.1 Refers)

The furniture in primary schools is of very poor quality and in some cases even non-existing, forcing small children to have to sit on the floor. The joinery in the chairs is a weak point. The back legs break away from the seat and the result is high annual repair costs. BACIP has designed chairs that are stronger, cheaper and easier to produce than existing school furniture.

- ◇ Low manufacturing cost is due to similar wood sizes of all pieces except the seat (allows fast machine pre-fabrication) and absence of joinery work (time consuming).
- ◇ The seat consists of two pieces to avoid shrinkage problems (cracking).
- ◇ Low assembly (labour) cost is also owing to the possibility of having the students assemble the chairs with the aid of a special assembly board (jig).
- ◇ The wooden H-frame and A-frame are fitted together by using an assembling jig.
- ◇ The connections of the BACIP chair are made with glue and galvanised screws.
- ◇ The BACIP design is very strong due to the absence of any joinery.
- ◇ The packaged design allows for low transport costs to remote areas.
- ◇ Adult size is 44 cm (sitting height). The chair is also available in lower heights (38 cm and 32 cm).

In addition to the all-wood design, a metal frame design with a wooden seat can also be provided. This design is slightly more expensive, but lighter in weight for transport and easier to assemble. In the classroom the metal/wood chair provides a more open structure.

On the following page is an illustration of the wooden school chair as well as the assembly board (jig) that allows the students to fit the pieces together in an easy manner. Only a screwdriver and a pot of glue are required.

Classroom Tables (6.7.2 Refers)

Traditional tables consist of a long, narrow (10-20") flat or inclined plank that serves three to four students at a time. The current limited amount of books or individual work does not merit larger tables. Combining tables in groups is not possible with the present furniture. BACIP-designed school tables are 60 cm x 120 cm (2 ft. x 4 ft.) and can be used by two students at a time. Maximum table size is 70 cm x 140 cm. In addition this furniture can be combined to make larger work surfaces and utilised for a variety of activities. Two different surfaces have been proposed. Both types of table tops are protected with a wood siding that locks into welded metal tube frames.

- ◆ Formica (on 3/4" chipboard). A thin white Formica-type of coating is factory glued on both sides of the board. The board comes in different densities, but for school tables the highest density is required. However, the table cannot be left wet or stand out in the rain.
- ◆ MDF (Medium Density Fibreboard) table (1/2" board) with glued on real Formica (stronger Formica than the above table). This table is more costly than the Formica table, but is lighter in weight and less vulnerable to water damage. The higher price is partly due to the need to glue the thicker Formica on the MDF boards by hand.
- ◆ A white coated (plastic) variety of table top exists, but this is of poor quality and not recommended.
- ◆ Table tops and leg frames can be stored separately, thus requiring little space.
- ◆ A stacking school table can be made using the same basic designs as the above table tops. This design has the legs on the outside. The assembled tables can be stacked 10 high. A disadvantage is that the narrower (width) sides cannot be placed together to form one long table.

SMALL CHAIR
WOOD

2 x 6 cm

H 32 cm

B 60 cm

W 33 / 41 cm

D 35 cm

ASSEMBLE
WITH GLUE
AND 1 1/4"
GALVANISED
SCREWS



PUMP
SCREW DRIVER

GREEN TOPS

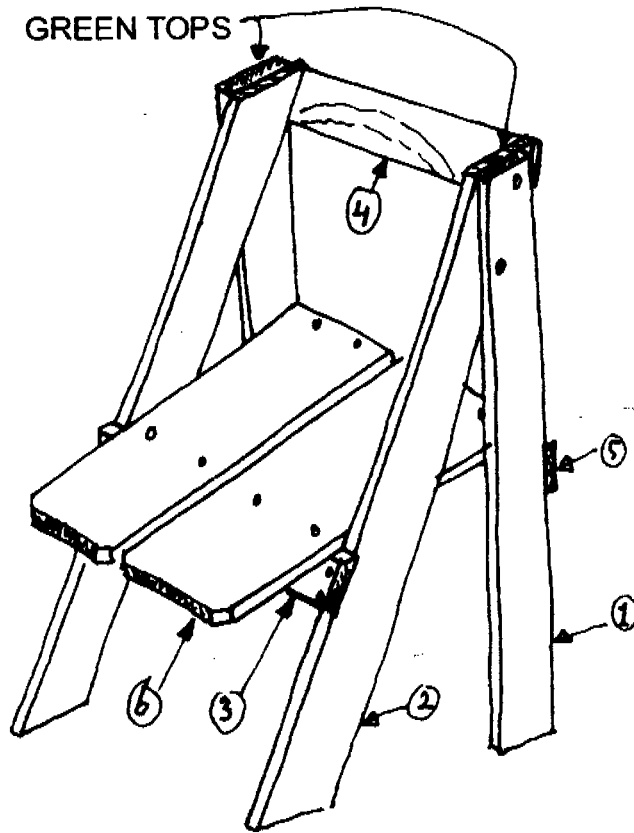

ASSEMBLING BOARD
SIZE 3/4" x 53 cm x 53 cm
PAINTED GREEN

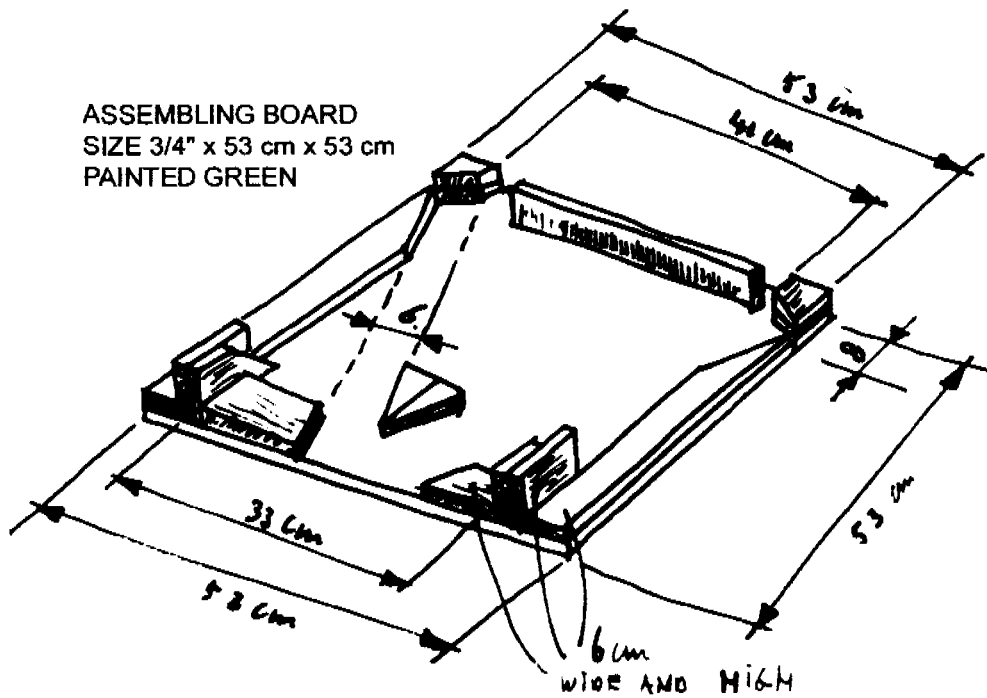

Movable Bookcase (6.7.4 Refers)

In many villages school books need not be taken from the school as often in the home there are no study facilities or electric light. In some cases the school has only one set of reference books (atlases, picture books, encyclopaedia) that should not be taken home. To store these books three options exist: a store room, a built-in wall bookcase or a rolling bookcase.

MOVABLE
BOOK CASE
24 GAUGE
TRUNKS

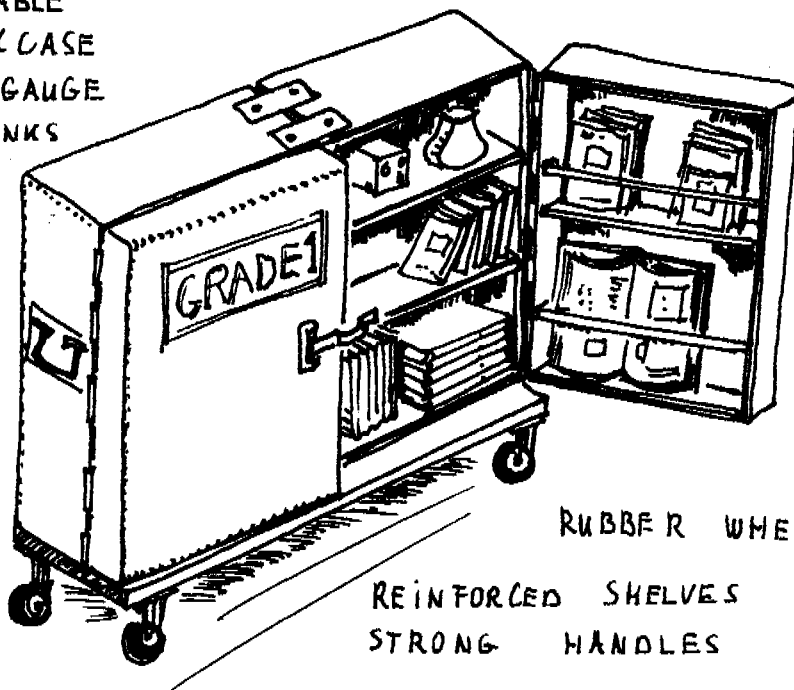

IN DOOR
SMALL BOOKS
AND
LARGE BOOKS
"SHOW CASE"

RUBBER WHEELS

REINFORCED SHELVES
STRONG HANDLES

BACIP has developed a movable bookcase, large enough to store 50 kg of books of different sizes and strong enough to roll from one classroom to another. The movable bookcase has two doors, is made from 24-gauge (0.56 mm) galvanised sheet metal and is fitted on 2" rubber/plastic wheels. The design is based on two metal travelling trunks fitted together. The bookcase can be manufactured by any trunk maker.

First a model using 28-gauge galvanised sheet metal was made but this easily ripped apart. Then a model was made from 26-gauge which proved sufficiently strong, but wobbly. Finally the 24-gauge model was of acceptable quality to carry 50 kg of books.

Kitchen Work Top/School Science Table (6.7.5 Refers)

Given the severe cold and scarcity of water, another major improvement requested by the women of the villages is a washing space for utensils or a sink within their house. Present kitchen arrangements in the traditional room are non-existent.

BACIP designed a low tabletop or sink of smooth 28-gauge (0.38 mm) galvanised sheet metal that can be placed directly next to the *bukhari*. The water drains through a standard "waste" hole and collects in a bucket placed underneath. The tabletop is equipped with a movable wooden chopping board (1" x 16" x 16") covering half the tabletop and a drawer for utensils. The present model is 2.5" deep, but deeper or flatter models can be made on request. The design is low-cost, simple and can easily be manufactured by carpenters and finished off by local tinsmith. A more expensive model is manufactured with a standard stainless steel sink.

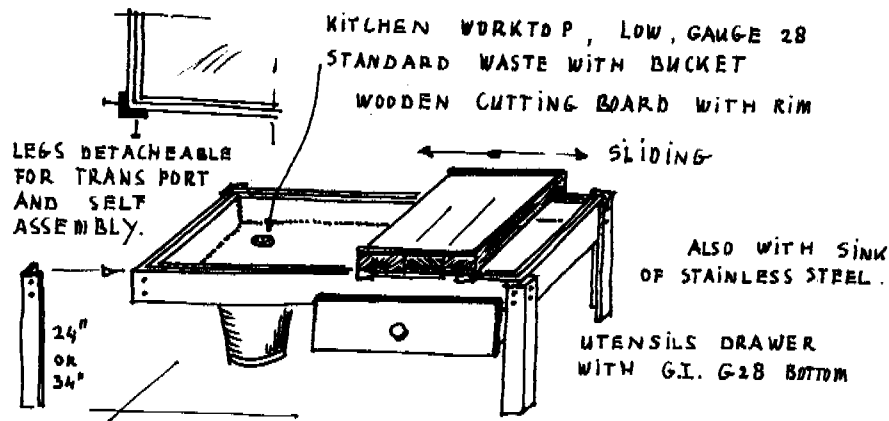

As many women want a change in habits, a high model of the kitchen work top was made. In addition a cabinet with a ventilating screen door can be fitted underneath. This high model can be used as a school science table for natural science education. It can also serve as a table for (wet) crafts work.



PROMOTION OF THE KITCHEN WORK TOP AND WOODEN CHAIR AT A ROAD SHOW

Kitchen Utensils Cabinet (6.7.6 Refers)

Washed dishes are left in the open to dry. In the summer this may be outside in the sunshine, but in the winter this is on open shelves inside the house. Outside there is the problem of flies, whereas inside it is dusty and smoky. In the traditional houses, there is usually an open shelving system located against the rear wall behind the *bukhari* for storing pots, pans, dishes and cooking utensils. Occasionally the shelves are covered by a cloth curtain to keep dust and flies off the dishes. In the houses of the richer villagers, wooden or glass door cabinets are constructed to store the best china.

The request from many women was for BACIP to provide a kitchen cabinet model. The design developed has the following features:

- ◇ Cabinet measuring 3 ft. x 2 ft. (or 3 ft. x 3 ft.) that hangs on the wall, free from the floor.
- ◇ Storage place in the 5" deep doors.
- ◇ All articles can be easily reached when the cabinet is opened.
- ◇ Fly screen (metal) in the door for fly-proofing and ventilation (wet cups, etc.)
- ◇ Hanging place for spoons and utensils.
- ◇ Painted wooden framework and lightweight galvanised sheet metal shelves.
- ◇ Pre-manufactured components in an Assemble-It-Myself (AIM) package, with a manual.
- ◇ Due to compact knocked-down design, low transport costs and little damage can occur in transit.

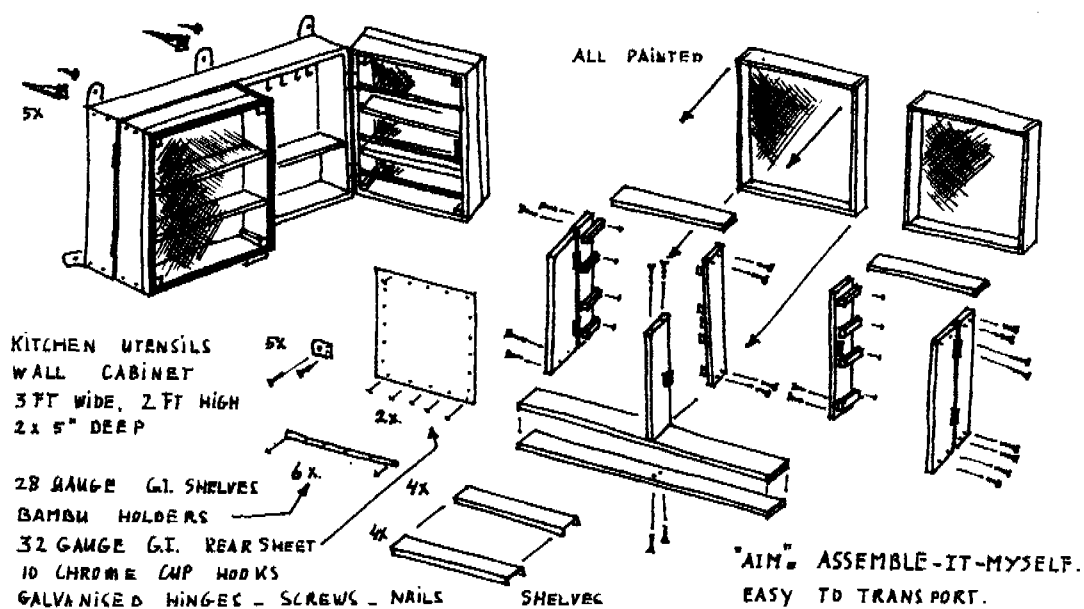

Space Planning (7.1 Refers)

Villagers use the services of local masons or contractors for designing and planning their houses. If they can afford the services of engineers from the Public Works Department (PWD), they will buy a design for a few thousand Pakistani rupees. The process of house planning with the help of engineers is non-participatory. As these designs are generally based on urban centre houses, the result is an uncomfortable house unsuitable for the climate of the Northern Areas. In many cases the PWD design is not followed as it doesn't fit into the local features of the terrain. Nor do these designs take the budgetary implications for the house owner into consideration, resulting in the house remaining incomplete or poorly finished.

BACIP has developed a simple three-dimensional tool for house planning and village cluster planning. The house planning tool consists of a planning board with a grid and modular pieces (in scale from 3 ft. to 12 ft.) to represent different building construction components, e.g. walls with doors and windows in different shapes, sizes, material, quality and finishes. The planning tool gives the villagers the freedom to choose a design and see how they can actually realise the proposed house in phases and within their available budget. The tool allows the planning of more than one storey buildings and demonstrates how the higher storeys are positioned over the lower floors. The planning of multi-storey buildings is a high priority development in the Northern Areas to avoid scarce agricultural land being used for housing.

The planning tool can be used by groups of householders who wish to plan their houses with the village-based resource persons and under the guidance of a BACIP consultant architect. The local resource persons or village co-ordinator will be able to use the tool together with the residents. The tool can be rented to a village for groups of five or more clients.

For the renovation of old village clusters, the tool can be used to plot out the existing situation and present a clear three-dimensional proposition of the renovation process.



The use of the house planning tool is an important first step in the following process:

- Planning a design for an existing or new house. Sample designs are given.
- Transferring the design to transparent graph paper. This paper comes in pre-printed sets for multi-storey houses and is supplied with the tool.
- Upgrading the design by the BACIP consultant architect and including reinforcement drawings.
- Costing of materials and inputs. Budgeting and phasing the implementation.
- Decision making on the timing of the implementation phases.
- Financing of improvements (future small-scale loan scheme).
- Collecting and purchasing of building materials.
- Contracting of services and actual construction.

A detailed research document entitled *The BACIP House Planning Tool (October 1999)* is available from BACIP.

Separation and Composting Toilet (8.2 Refers)

Traditionally villagers in the Northern Areas have in-house or attached latrines called *chukan* or *chaksa*. These latrines (many of which are built over cow sheds) have several holes in a soil floor through which faeces and urine drop into the area below. The hole is often missed and urine gets soaked into the soil floor. In addition fly-control is non-existent or inadequate. Ablution practices do not improve the situation. These dry latrines do not allow for post construction maintenance, such as cleaning or sanitary composting. Most villagers recognise that there is a strong need for improved sanitation. In many areas composting of mixed cow/human dung is practised. In some cases houses were encountered having no sanitation facility at all.

In view of the affordability and local requirements, double vault composting dry pit latrines are an appropriate option as there is a large need for quality compost. The design developed by BACIP is an improved combination of the well-known "Vietnamese Double Vault Composting Latrine" and the research findings of the current Water and Sanitation Extension Programme (WASEP) of the AKPBSP. The result is a clean looking, sanitary "separation and composting toilet" that allows the same room to be comfortably used as both a toilet and bathroom, without unnecessary wetting of the compostable components.

- ◇ Prefabricated form work elements for easy casting of the concrete floor.
- ◇ Thin floors with galvanised iron reinforcement (no corrosion) and without the use of wood.
- ◇ White ceramic toilet elements that look good and can be easily cleaned.
- ◇ Wooden planking over the central pan to avoid contact and keep warm footing.
- ◇ Avoidance of water infiltration into the compost pit. Separate frost-free drainage of wash water.
- ◇ Possibility to close the composting pit for one year, with high quality compost output.
- ◇ Can be fitted in existing or new housing projects and cluster re-planning.
- ◇ Simple removal of the good quality compost after maturation.

DOUBLE VAULT SEPARATION
AND COMPOSTING TOILET
CERAMICS AND CEMENT FLOOR
PREFABRICATED FLOOR MOULD

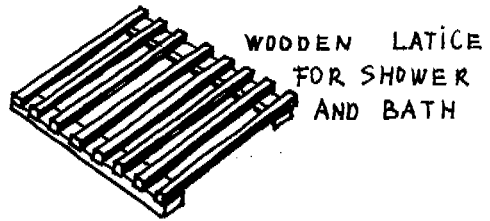

WOODEN LATTICE
FOR SHOWER
AND BATH

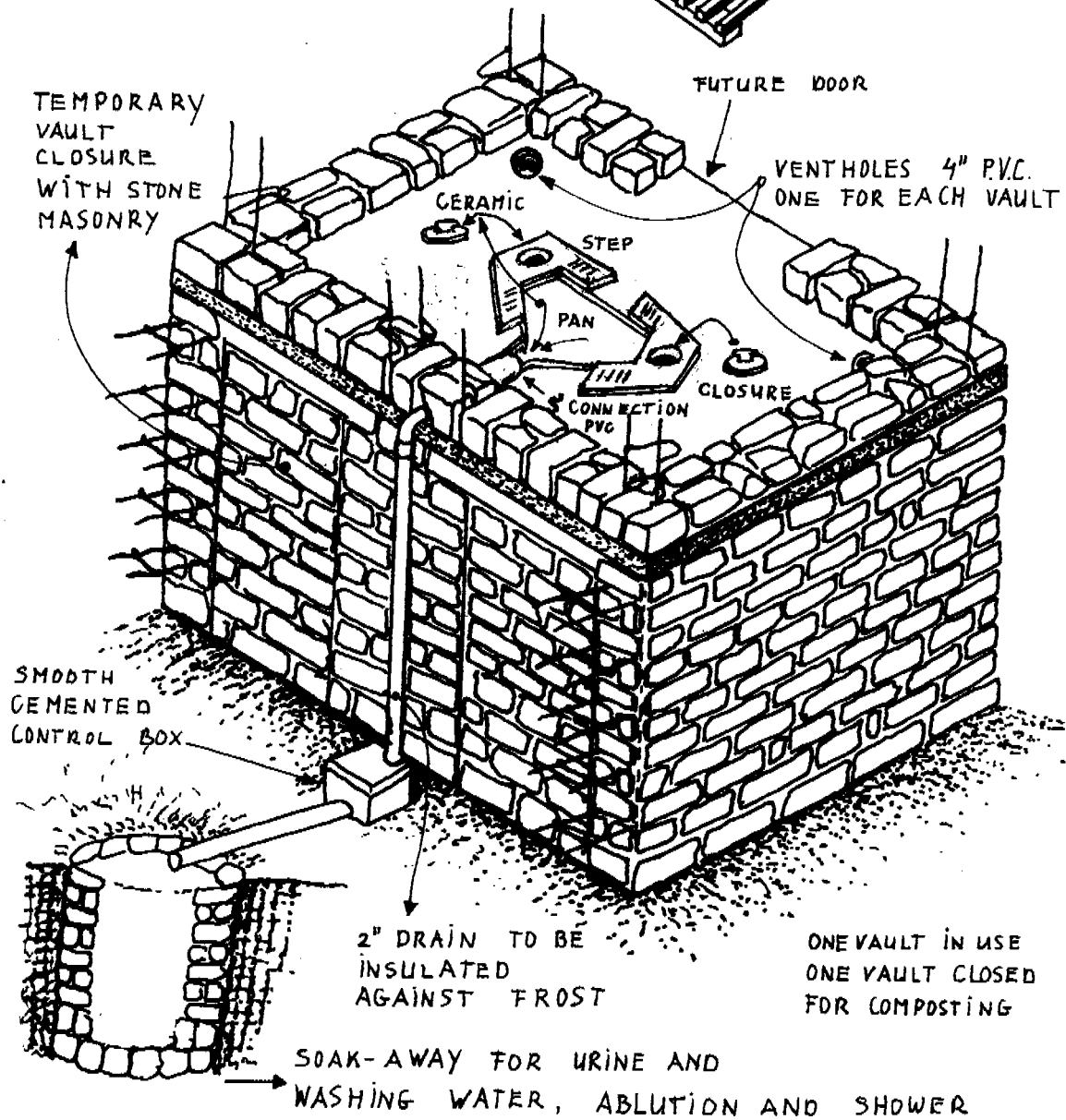

Illumination (9.1 Refers)

Many houses have poor illumination. A number of reasons can be mentioned: no window openings other than a small hole in the roof, no light fixtures (also applicable to those villages that have access to power supply), soot and smoke blackened walls and roof structures, and no maintenance. The result is that few activities, such as handicrafts or reading, can be done inside the house.

In addition to improved illumination through introducing roof hatch windows and better side windows, fluorescent tube lights have been promoted with properly installed electrical switches. Together with the fitting of a fluorescent tube light, the villager needs to lighten the inside plaster of the dark house by whitewashing the area. The two inputs enhance each other and create an improved illumination level inside the room. In some cases the house owners started to clean the rest of the house as well.

In a rather old house, a proud women showed us her own improvement. She had cleaned the large, old and richly decorated wooden utensils cabinet that was fitted in the rear of the traditional room and had been blackened by 100 years smoke attack. "Before the installation of the tube light, I didn't see a thing, but with the additional light I realised how nice the carved woodwork was." (See photograph below)

The fluorescent tube lights give a high light production against low energy consumption. In most cases the common starter does not function with low or fluctuating voltage supply. An electronic starter is therefore essential for low voltage power supply.

The fluorescent tube lights are fitted with a white metal protective sheet over the lamp (4 ft. long, 32-gauge). It was found that in the older houses a thick layer of dust (falling from the roof) and smoke (from the fire) settles on the tube, reducing its illumination effect. In addition the light projected to the black ceiling is largely absorbed. The metal protector sheet keeps the tube clean from ceiling dust and projects the light to the centre of the room or the cooking area.



Fluorescent Tube Light Protection Cages (9.2 Refers)

In places where the fluorescent tube lights can be easily damaged, a protective cage can be made over the light. BACIP has developed two types for use in schools and in communal areas.

One is made of light, galvanised expanded metal mesh (20-21 gauge). This model can resist the impact of badminton shuttles and table tennis balls.

The other is made of heavy expanded metal mesh (12-14 gauge), painted first with an anti-corrosive primer and then finished with a coat of white paint. This stronger cage is screwed onto the wooden beams that carry the tubes. This model can resist the impact of hand and volleyballs.

Solar Lamps (9.3 Refers)

Irregular electricity sources or total lack of electricity deprives the villagers from realising activities in the evening hours. Solar lamps are based on a compact rechargeable gel battery, electronic switching circuits, a small low-energy fluorescent lamp (11 watt) and a separate solar panel. The initial cost of the imported lamp is somewhat high at about Rs. 10,000 but as the lamp lasts for 10 years and costs the same as the 3-year operational expenses of compression kerosene lamps (fuel and mantels), in the long term it is more economical.

The advantage of the solar lamps is that they last long (10 years or longer), are very easy to operate and provide instant light. During the daytime the lamp is connected to a solar panel which charges up the battery. The current Nesté solar lamp provides an equal number of night-time light hours as the number of hours of direct sunlight the panel receives during the day. The solar panel must be positioned to receive the maximum sun radiation during the day.

The disadvantages are the high capital investment at the beginning and the fact that the lamp does not radiate heat as is the case with gas or kerosene lamps (important in the winter).

Considering the current economic situation of the local population and the need for heat source in winter, the advantages do not counter the disadvantages.

Solar Home Systems (SHS) may eventually become economically feasible for remote clinics and schools. For schools the system needs to be complemented with a large number of rechargeable torches for use by the students or school users to light the way home after evening school sessions.

E. OTHER BACIP PRODUCTS

Earthquake Simulation Table

This is an educational tool that simulates the effect of an earthquake on a wall construction. In the Northern Areas and Chitral the reality of earthquakes is often not understood by the population. The quality of the construction is getting worse while the volume of the constructed buildings or houses is increasing. No measures are being undertaken to make houses better resistant against earthquakes. The table demonstrates (on a scale of 1:6) the different effects an earthquake has on a non-reinforced wall as compared to a wire-reinforced wall. The mini-wall construction is built by using small blocks or stones, with and without the reinforcement. The table is fitted on calibrated springs to simulate the earthquake movements. After construction of the mini-size walls is completed, the side of the table is touched to cause the slow vibration.

The model also clearly demonstrates that the building of a construction is more time consuming than the time an earthquake takes to make a house collapse. The shake table works excellently, but due to many hours required to reconstruct the mini-walls after each "earthquake", it is only sparingly used. Fortunately only the non-reinforced wall collapses.

Wheelbarrow

BACIP has adapted the existing common wheelbarrow with only a slight modification. The BACIP wheelbarrow is more stable because the handles of the wheelbarrow are placed wider apart (more to the outside), increasing the distance between the handles from 20" to 24". This creates a better balancing control over the side movements. A further improvement is being developed for wheelbarrows that are to be used on small mountain roads. This improvement will entail lowering the container more to the ground, by which the mass point (weight) becomes lower in position. This will also increase the stability and balance. Making the container smaller may be necessary for very steep mountain tracks.

The manufacturers first insisted that the handles needed to be as wide as the tub for ease of making (20"). None of the city manufacturers had ever asked the users of the wheelbarrows if they were satisfied with the model. Apparently, due to centralised production, the design evolved according to manufacturing criteria and did not take user criteria into consideration. In this case BACIP acted as the intermediary organisation that was able to transfer the user requirements to the manufacturer for making a better product.

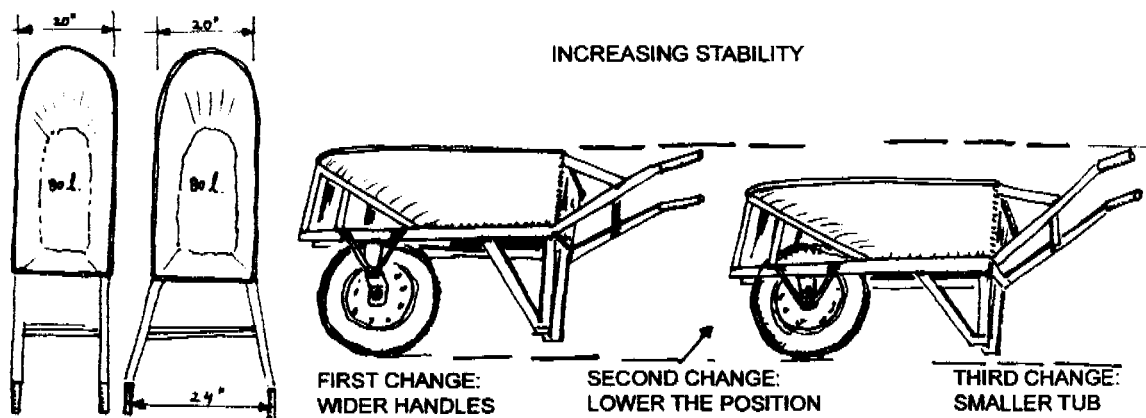

L- and C-Shaped Cement Blocks

Both C- and L-shaped cement blocks are necessary for constructing walls and wall endings when applying the galvanised wire-mesh wall reinforcement technique. The blocks allow the placing of vertical reinforcement either with the galvanised wire-mesh technology or with iron bar reinforcements. In addition they facilitate fast and straight masonry work.

The moulds used for casting the cement blocks are described in the document: *GALVANISED WIRE-MESH WALL REINFORCEMENT METHODOLOGY – Application of the BACIP Wire-Mesh Reinforcement (December 1999)*.

The blocks must be cast on a flat surface and are compacted with a "walking rack", hence the description of "rack moulds". With one mould two blocks are cast at the same time. Two different shapes of blocks are manufactured:

- ◇ The two C-shaped blocks are 12-inch wide and can be split into two pieces (making two small L shapes) to accommodate wider walls or small corners.
- ◇ The two L-shaped blocks are 12" x 6" or 16" x 8" each.
- ◇ The advantage of both the C- and L-shaped block design is that the corners of the walls can be masoned straight up (one block at a time). With a masonry line stretched between the corner blocks, the horizontal layer of stone masonry can then be filled in.
- ◇ The use of the straight cement blocks in the corners of the building and along door and window frames will not only increase the speed of the masonry work considerably, but provide neat, straight edges along the wall endings.
- ◇ Between the C- or L-shaped blocks (at the corner or ending of the wall) and the horizontal stone masonry, the vertically placed galvanised wire-mesh wall reinforcement functions as vertical wall reinforcement.
- ◇ This reinforcement design creates a coherent side framing of the wall section and is necessary for enhancing the strength and function of shear walls.
- ◇ The use of the C- and L-shaped cement blocks on the wall endings and along the vertical sides of the doors and windows gives architecturally an appealing sight.
- ◇ Several types of block moulds can be supplied depending on the required size of the C- or L-shaped blocks. This depends on the wall thickness.

The same mould design can be made and used for the casting of hollow cement blocks.



Cement Mortar and Concrete Quality Tester

Excellent types of aggregates can be found in the Northern Areas which can be used for concrete. Concrete and cement mortars vary in quality according to the types of aggregates used and the casting and curing processes. Little experience exists in the Northern Areas on how to make good quality concrete. Only in the two main towns (Gilgit and Skardu) hydraulic equipment exists to test the quality of concrete cubes.

A simple tester has been developed by BACIP to test the mortar and concrete quality:

- ◇ The same mortar used for making cement blocks or concrete is cast into small moulds to make cubes measuring 1.25" by 1.25". This is the thickness of the hollow cement blocks.
- ◇ After the required hardening period, the cubes are tested using a lever arm.
- ◇ A rubber cushion (car tire) is placed on the top and bottom of the small cube.
- ◇ At the end of the lever arm (handle side) weights of 10 kg are hung.
- ◇ For each weight the resistance of the small cube is 100 psi.
- ◇ When 5 weights of 10 kg are hung on the arm, the total resistance of the cube is about 500 psi.
- ◇ The quality of the cement blocks or concrete can be tested at almost any location with this inexpensive lever arm.
- ◇ A testing result table is supplied with the equipment.
- ◇ For making improved mortar quality, especially for hollow cement blocks, the entrepreneur needs to know the type of quality he/she is able to manufacture.
- ◇ With the available concrete aggregates found in the Northern Areas, good quality concrete can be made if the entrepreneurs are able to control the quality.
- ◇ Block makers are not interested in the tool as only solid cement blocks are made and only the price is relevant to the buyers.



Compacted Adobe Blocks

Clay soil is a common construction material in the Northern Areas. In some valleys ample good quality clay soil is available for house construction. To increase the compressive strength of the clay soil blocks and wall construction, new blocks moulds have been designed that help to produce compacted soil blocks. The high compressive strength soil blocks are suitable for multi-storey houses and houses that can better withstand earthquakes. The combination between the compacted soil blocks and the galvanised wire-mesh wall reinforcement will further enhance the strength of the wall constructions.

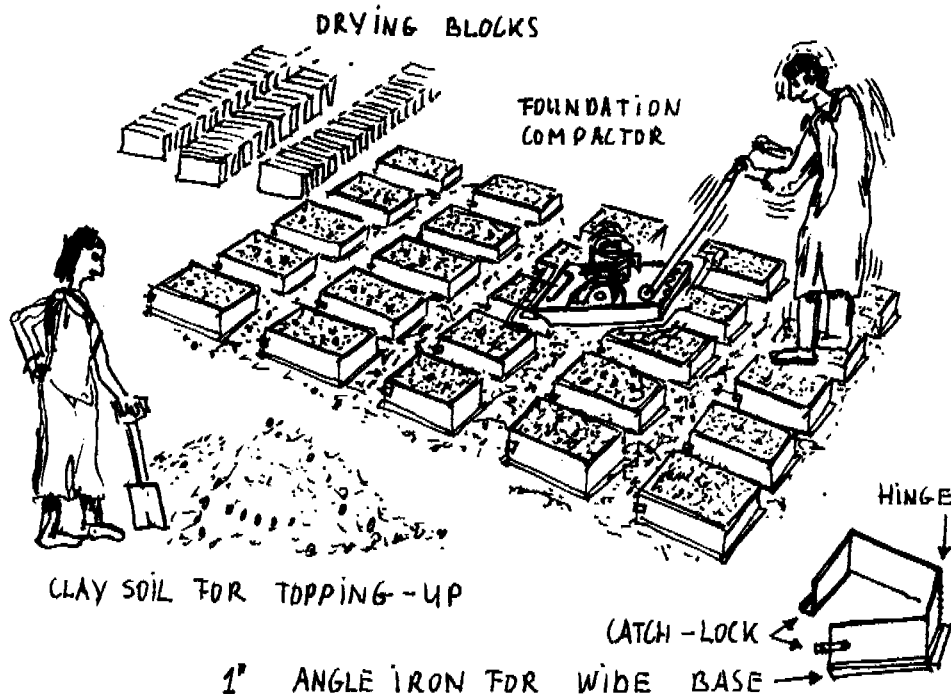

- ◆ A cemented or concrete area is made to manufacture the compacted adobe blocks. This can be the compacted floor of the foundation of a new house. In this way the transport of the manufactured dried blocks will be minimal.
- ◆ Compacted adobe blocks should preferably be used only above plinth level. Below the plinth level stone construction or cement blocks are recommended.
- ◆ Individual sheet metal block moulds for solid blocks are placed together on a flat area (4.5" h x 8" w x 12" l). The moulds have a widened rim at the bottom to increase their bearing on the ground.
- ◆ The moulds have a side opening, similar to the solid cement block moulds.
- ◆ The moulds are filled with sandy clay soil (maximum 50% clay). The soil can contain little stones or gravel and does not need to be sieved as would be necessary for current methods of compacted adobe block making, thus saving work.
- ◆ A small soil compactor/vibrator machine is run over the filled moulds. At the same time the moulds are additionally filled until no more soil can be added.
- ◆ The height of the blocks is limited (4.5"). With thicker blocks, the compacting inside the blocks will be less.
- ◆ After compacting, the moulds are opened and the blocks placed to the side to dry. Blocks that fall apart in the repositioning are of inadequate strength.
- ◆ To determine the correct soil-clay mix several compacting tests have to be made with different soil compositions.
- ◆ The wall construction is reinforced with the BACIP wire-mesh wall reinforcement.

Solar Fruit Dryer

In the Northern Areas a large number of agricultural products are dried in different seasons. Solar drying is efficient due to intense solar radiation and low air humidity, but does affect the colouring and taste of many fruits and vegetables. In addition, drying on rocks, woven willow branch mats or soil roofs of the houses allows both dust and flies to affect the quality. Open-air dried products therefore involves wastage of produce and is not sanitary enough for commercialisation. For commercial projects expensive solar dryers with glass have been introduced and for domestic production sulphur fumigation. This affects both the colour and taste of the products. Some of the products that are dried are: apricot, grapes, tomatoes, meat, beans, peppers, apples, nuts and mulberries.



TRADITIONAL DRYING OF TOMATOES ON WILLOW MAT, PLASTIC AND IN A WOODEN BOX

The BACIP solar fruit dryer is constructed like a sandwich. It consists of two galvanised sheet metal covers with a wire-mesh mounted on a wooden frame sandwiched in-between. The design has the following advantages:

- Unbreakable (no glass parts) and light enough to be transported by one person.
- All local materials, can be made by local craftsmen. Low cost.
- Non-transparent, thus ultra violet light does not affect the colouring of the food.
- Increased drying speed (double) as compared with open-air drying.
- Hygienic, no dust or flies. Especially grapes and apricots attract a lot of flies.
- Increased product value for products sold at the market.
- Small in size (3 ft. x 3 ft.), but large enough for one small farm production.

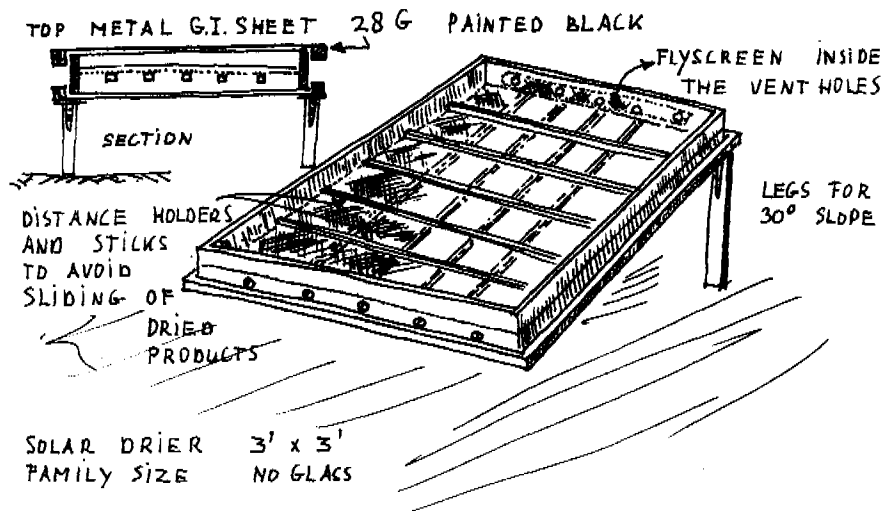

THE BACIP SANDWICH UNBREAKABLE FAMILY SOLAR FRUIT DRYER

Public Address System

An objective of group meetings in villages is to address all villagers, men and women alike. Due to local *purdah* customs and regulations, women are often kept away. Depending on the predominant religion in a village, first and foremost women are often not allowed to participate in the discussions and secondly they are excluded from listening to the discussions. However, the opinion of the women in household improvements is essential as they are also users of the improvements or have to maintain the domestic facilities. In addition the observations and concerns from the women can help the project to design better solutions. The project therefore needs to stimulate the women in commenting on the models. Group meetings in villages must be carefully organised so as to involve the women adequately, without conflicting with the current *purdah* customs and regulations.

The meeting should not only be organised with the women, but also for them. They should be able to follow the discussions and have an insight into all possible aspects of the improvement. The BACIP sound equipment (public address system) allows for two-way communication without disturbing the local *purdah* practice and appears to be very useful for this purpose. With the microphone and speaker cables being 100 yards in length, the women and children are able to gather in a place that affords them privacy, either in a house or an enclosed yard. During the meeting, the men can talk first about the male tasks and interests (new house construction) and afterwards the women are free to express their opinions (from their remote position).

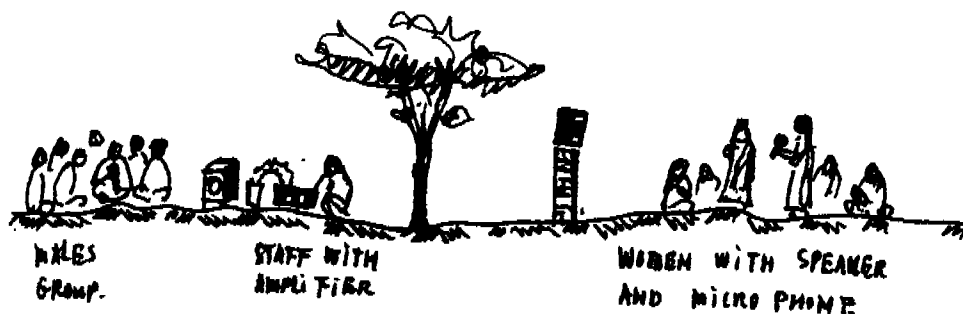

BACIP Blanket

During the summer the sun is extremely hot and causes strong evaporation of wet concrete or cement mortar. This means that any cast concrete or freshly masoned structures need to be kept wet for at least two weeks. This is rarely the case, especially not in the villages.

The BACIP blanket, when made wet, avoids excessive evaporation of water and can be attached to columns or lintels and hung over fresh masonry work. When applied it protects the fresh masonry from overheating in the sun and reduces the amount of water that has to be transported to the construction site. In addition the same blanket can be used in the colder periods to protect fresh masonry or concrete from under-cooling at night due to strong wind or frost.

The blanket measure 3 ft. x 6 ft. and is made from four old (second-hand) jute bags sown together on a small tarpaulin. The blanket also proved to be useful for packing goods for transport and to sit on during meetings. An improved version of the blanket is used to cover the roof hatch window as an alternative to the metal sheet shutter.

BACIP: "For additional insulation at night, you can place the BACIP blanket over the glass of the roof hatch window."

Villager: "I would rather use that blanket it in my living room as a carpet."

Solar Tent for Building in the Winter

The winter season in Gilgit (the lowest and warmest area in the Northern Areas) starts mid-November or begin-December. The overnight temperatures are then under zero degrees Celsius. Night frost will cease by March. During these months daytime temperatures will reach 10-12° Celsius in the shadow.

For curing cement mortar (or concrete) a minimum temperature of 5-10° Celsius is needed. At lower temperatures the hardening process stops and the resulting mortar quality will be inferior to what is recommended or calculated. Considering the above, the cement work should stop by mid-November and restart March at the earliest (in Gilgit at 5000 ft.). This is not the case, as the months of November and February are the months that no substantial agricultural activity can be realised and labour can be obtained for construction work. Hence the contractors try to continue to work until the mortar almost freezes when mixing the cold aggregates.

An increase of altitude means colder weather. Most villages are at an altitude of 6000 ft., whereas villages that do not receive sun must be considered as villages of at least 1000 ft. higher because the sun does not warm the stone aggregates. The highest villages are at an altitude of almost 9000 ft.

BACIP: "What do you think of the plastic tent?"

Labourer one: "We are so warm we have to take our sweaters off."

Labourer two: "At least we still have some work, the other project stopped two weeks ago."

Supervisor: "It works like a greenhouse."

The following table is an approximation based on information from local builders. Local contractors will try to continue for two more weeks into the first night frost period, producing poor cement quality.

In the table, a "+" indicates the weeks that cement can be used and a "-" indicates when it is too cold (less than 5° Celsius at night). Overnight evaporation of water will additionally cool down fresh masonry. A minimum four hours of daily sunshine has been considered.

Village	Altitude	Sept	Oct	Nov	Dec	Jan	Feb	Mar	April - August
Gilgit	5000 ft.	++++	++++	++--	----	----	----	++++	++++
Hunza	6000 ft.	++++	++++	+---	----	----	----	-+++	++++
Hoper	7500 ft.	++++	++++	----	----	----	----	--++	++++
Sost	8000 ft.	++++	+++-	----	----	----	----	---+	++++
Phandar	8500 ft.	++++	++--	----	----	----	----	----	++++

The above means that the building season (with cement mortar) in the winter is rather short. The BACIP solar tent extends the building period by one month on each side of the cold season.

The following observations can be made:

- ◇ It can only be used on building sites that have direct sunlight in the winter for a minimum of five hours.
- ◇ The supporting frames are made of bamboo poles, being very light and easy to carry up into the higher mountain villages.
- ◇ High transparent plastic foil is used to capture the sunlight. The strips are fitted to plywood for easy attachment to the bamboo frames. In the plywood strips holes are made for fitting ropes.
- ◇ The construction cannot be used in areas where strong winds are expected as the wind will carry the whole tent away like a kite or rip it apart.
- ◇ The direct sunlight, when projected on the stone mass, converts into heat and the heat is absorbed by the stone masonry work. The stored thermal heat releases the heat during the night, maintaining the temperature inside the tent.
- ◇ The solar tent not only increases the inside temperature and the heat accumulation by the stone mass, but the double tent avoids wind cooling at night. Both factors contribute considerably to maintaining an adequate inside temperature.
- ◇ The average temperature inside the solar tent is about 10° Celsius higher than the outside temperature in the shade.
- ◇ For additional insulation the fresh masonry work is covered with dry BACIP blankets. The transparent plastic is covered at sunset with polypropylene tarpaulins. The tarpaulin creates an additional insulating air layer.
- ◇ In areas where high snowfall is expected, the roofing of the construction needs to be well inclined as the plastic cannot bear a snow load.
- ◇ Part of the used plastic can be used in the finishing of the building.

Advantages: The building season can be extended in a period that no other work is available for unskilled labourers. The lower labour cost pays part of the investment.

Problems: The transparent plastic foil (table covering 0.15 mm) that is found in the local market becomes brittle and cracks with night frost, thus creating spontaneous holes in the solar tent. High strength, transparent, UV resistant, glass fibre reinforced plastic foil can be obtained (imported?), but an economic assessment needs to be made first.

F. BACIP CATALOGUE

To present the BACIP house improvement options to the villagers, a trilingual (drawings, English and Urdu) catalogue will be placed in every participating village. The catalogue will eventually contain the following information:

Volume I (Available with the Village Co-ordinator)

- An index.
- A promotional poem on the BACIP principle.
- A short description of the BACIP Programme with its objectives.
- A list of the participating villages, village co-ordinators and resource persons (per region).
- A detailed code list of the items which will be for sale through the suggested sales network.
- Description of the conditions on how to become a BACIP trader.
- Order forms for materials or tools from the trading network (through trader or co-ordinator).
- Fact-sheets on the problems in the houses, with the different solution options.
- A general description with illustrative pictures of the various improvement options and an explanation on when to choose what type of solution.
- A brief technical and financial description of each improvement option and an order form for the products or materials. The same order form is used for buying the manuals.
- Information on how to obtain training on manufacturing the house improvements and participation in a "host" training visit, along with an application form.
- Information on how to obtain house planning or cluster planning, with application form.
- Other relevant material.

Volume II (Available at the BACIP Main Office Only)

- An index.
- Manufacturers manuals on each of the products (including manufacturing procedures) and quality control checklists.
- An order form to requesting photocopies of the above pages or documents from BACIP.
- Other relevant material.

The BACIP catalogue will be in a loose-leaf binder so that additional pages can be added containing the latest improvement options. The catalogue will remain the property of BACIP and should not be lent out to the villagers. It should only be consulted in the presence of the village co-ordinator or the resource persons. In this way the co-ordinators will gain a better understanding of the issues and eventually be able to provide full information to the villagers and the catalogue will probably not get lost.

ANNEXE I - CODE LIST HOUSE IMPROVEMENTS

ANNEXE I

Aga Khan Planning and Building Service, Pakistan

BUILDING AND CONSTRUCTION IMPROVEMENT PROGRAMME - BACIP

Field Database per Village for Home Improvements (existing and new)

All Regions

General code sheet per type of improvements in each category

Upgraded version December 1999

The BACIP village Catalogue will be organised according to the same categories.

In the datasheets per village the following main categories are to be indicated

	1	2	3	4	5	6	7	8	9	10
Main	Roofs & Ceilings	Stoves & Chimneys	Windows & Doors	Foundation & Retain	Walls & Wardrobe	Floors & Furniture	Space Planning	Water & Sanitation	Power & Energy	Other & Tools

Main category	Sub-categories	Drawing numbers	
		Code	Subcode

1			
Roofs & Ceilings	New roof construction and structural roof diagramme		1.0.
	Galvanised roof sheets of different gauges with fittings		1.0.1
	Square folded roof profile sheets 1.5" x1.5" with concrete topping one inch		1.0.2
	Insulation under existing GI roof with plastic, wire-mesh and woodcurls		1.0.5
	Insulation over existing GI roof with woodcurls, plastic wire-mesh/plaster		1.0.6
	Insulation on existing concrete roof with woodcurls, plastic, wire-mesh/plaster		1.0.7
	Improvement of roofs against leakage with plastic sheets and gutters, gargoyles		1.1
	Plastic sheeting 0.1- mm thick coloured /recycled (42 gauge)		1.1.1.a
	Plastic sheeting 0.15 mm thick transparent (more sun resist)		1.1.1.b
	Asphals paper roof waterproofing		1.1.2
	Roofspouts (gargoyles) short, medium or long, corrugated overhang sheets		1.1.3
	Stabilised or cemented roof topping (1 : 15) in new slope		1.1.4
	Making of roof border and parapet walls, fencing etc		1.1.5
	Improvement of roof structure, reinforcement, diaphragm, anchorage		1.2
	Beam, wood construction with composite wood/ GI metal sheet		1.2.1
	Beam, wood construction with bowstring, GI wire and shoes		1.2.2
	Retrofitting or creation of Roof Tie-Beams		1.3
	Concrete or cemented roof tie-beams, anchors cast-in (retrofitting)		1.3.1
	Wire-mesh roof tie beam and wall anchorage		1.3.2
	Steel bar anchors alongside walls (lintel level) for retrofitting		1.3.3
	Roof hatch, with glass, shutter and ventilation		1.4
	3 ft x 3 ft roof-hatch window with rear vent. With various options		1.4.1
	2ft x 3ft roof hatch window with rear vent and blanket. With options		1.4.2
	1.5 ft x 3 ft sun hatch roof light with rear vent. Various options		1.4.3
	1.5ft x 1.5 ft light shaft with single glass sheet		1.4.4
	False ceilings for dust control and thermal insulation		1.5
	Hardboard sheets (painted) on wooden strips		1.5.1
	Plywood sheets (painted) on wooden strips		1.5.2
	Gypsum, lightweight panels 2 ft x 2 ft		1.5.3
	Bambu matting		1.5.4
	Light paint or colour coating of ceiling for improved illumination		1.6
	Roof insulation on existing roofs		1.7
	Under corrugated roof sheets insulation		1.7.1
	Over corrugated sheet or concrete roof insulation		1.7.2

Main category	Sub-categories	Code	Subcode
---------------	----------------	------	---------

2			
Stoves & Chimneys	Formula One stove, cooking and room heating, different varieties		2.1
w = width	Double round 'buchari' HB model, 20"w, 32"l, 8"h, holes 17.5"+6.5", 3"ch.		2.1.0.a
l = length	Double round 'buchari' HB model, 18"w, 28"l, 6"h, holes 15.5"+6"+3"ch		2.1.0.b
h = height	Single metal top 18"w-12"w, 32"l, holes 12"+ 6", 3"ch, brick body 9"h		2.1.1
ch = chimney	Single metal top, 18"w-12"w, 32"l, chipatti +hole 6", 3"ch, brick body 9"h		2.1.2
a,b,c, different sizes	Metal top+sides, 17"w-4"w, 30"l, 8"h, holes 12"+ 6", 3"ch		2.1.3.a
	Metal top+sides, 17"w-4"w, 34"l, 8"h, holes 12"+ 6"+4", 3"ch		2.1.3.b
	Metal top+sides, 15"w-4"w, 32"l, 8"h, holes 12"+ 6", 3"ch		2.1.3.c
	Metal top+sides+brick lining for summer, 18"w-12"w, 32"l, 9"h, holes 12"+ 6", 3"ch		2.1.4
For single metal top:	Metal top+sides, 17"w-4"w, 30"l, 8"h, chipatti + hole 6", 3"ch		2.1.5.a
Extra cost of Rs 100	Metal top+sides, 15"w-4"w, 30"l, 8"h, chipatti + hole 6", 3"ch		2.1.5.b
16 gauge = 1.6 mm	Metal top+sides+brick lining for summer, 18"w-12"w, 32"l, 9"h, chipatti+ 6", 3"ch		2.1.6
	All metal 15"w-9"w, 30"l, 8"h, holes 12"+ 6", 3"ch, legs 2"		2.1.7
	All metal 15"w-9"w, 30"l, 8"h, chipatti + hole 6", 3"ch, legs 2"		2.1.8

	All metal+ brick lining for summer, 18"w-12"w, 32"l, 9"h, holes 12"+ 6", 3"ch, legs	2.1.9
gauge sizes	Additional fittings to stoves and heaters	2.2
30 gauge = 0.31mm	Straight chimney pipes 3"ch, plain flat steel 28 gauge	2.2.1.a
28 gauge = 0.38mm	Chimney bends, 45 degrees bend, 3"ch, one pair, 30 gauge	2.2.1.b
26 gauge = 0.45mm	Chimney bends, 90 degrees bend, 3"ch, one pair, 30 gauge	2.2.1.c
24 gauge = 0.55mm	Top oven (double walled) placed on stove, 14"w-10"w, 12"l, 6"h	2.2.3
22 gauge = 0.71mm	Ash tray for in front of the stove, 18" x 18" x 1.5"	2.2.4
20 gauge = 0.91mm	Water heating pipes inside stove 0.5" , one set, long 40"	2.2.5.a
18 gauge = 1.2mm	Water heating pipes inside stove 0.5"+1", one set, long 30"	2.2.5.b
16 gauge = 1.6 mm	Water heating pipe connections, flexible 16"+24", one set	2.2.5.c
	Water storage barrel, plastic, 200 liter, two outlets + tap.	2.2.5.d
	Water storage barrel, plastic, 130 liter, two outlets +tap	2.2.5.e
	Water storage barrel, plastic, 80 liter, two outlets + tap.	2.2.5.f
	Formula Two stove for water heating, laundry, washing	2.3
	Washing tub only. Wheelbarrow tub 80 litres	2.3.1
	Improved chimney roof outlet,	2.4
	feriferi for 3" pipe, complete	2.4.0.a
	feriferi for 4" pipe, complete	2.4.0.b
	Construction of new chimney or hood	2.4.1
	Roof passages for chimney outlet, fire, leakage control etc.	2.5
	Square/round passage for 3 inch chimney in flat traditional roof.	2.5.1
	Square/round passage for 4 inch chimney in flat traditional roof.	2.5.2
	G.I sheet manchet for passing to side wall for 3" pipe	2.5.3
	Creation of internal hoods or pipes in existing wide chimney channels	2.6
	Creation of a ventilation opening in walls, square or triangle	2.7
	Square hole with flyscreen and shutter 1.5 ft x 1.5 ft	2.7.1
	Triangular hole (no load) with flyscreen and shutter 2 ft base x 2 ft	2.7.2
in testing	Formula Three stove, sawdust stoves and heaters	2.8
	Two cilinder of 6" each in brick masonry, 2ft x 3ft x 4 ft	2.8.1
	Two cilinder of 8" and 6" in brick masonry, 2ftx 3ft x 4ft	2.8.2
	Metal concentric two cilinder, partitioned exterior ring (6)	2.8.3
	Compressor for making briquettes for two cilinder sawdust stove	2.8.4
	Solar dryer for drying compacted briquettes (same as fruit dryer)	2.8.5
proposed	Formula Four stove, coal burners with brick lining	2.9
	Cilindrical three ft high with one ft brick lining, one cooking hole	2.9.1
	Square three ft high with brick lining and two cooking holes	2.9.2

Main category	Sub-categories	Code	Subcode
3			
Windows & Doors	Improved window on sunside of the building, increased glass size, shutters,	3,1	
	Sunside with enlarged additional glass windows, no shutters		3.1.1
	Sunside with enlarged glass and shutters (wood + GI sheeting)		3.1.2
	Sunside window with removable white fly screen		3.1.3
	Improved window on shadow side of the building, double or shuttered	3,2	
	Shadow window with shutters (wood + GI sheeting).		3.2.1
	Shadow window with additional glass window.		3.2.2
	Fly screen fitted, fixed or removable		3.2.3
	Improved window insulation with curtains on sill, inside wall opening	3,3	
	Curtained window in front of the wall with four sides closures		3.3.1
	Curtained window inside the opening, closing four sides		3.3.2
	Creation of a new window or door for ventilation or light source	3,4	
	New window opening for light and ventilation		3.4.1
	New door opening for light and ventilation		3.4.2
	Fly screen door in existing opening		3.4.3
	Entrance improvement related to draft of cold air	3,5	
	High step over floor plank to stop low draft		3.5.1
	Double door construction to prevent draft		3.5.2
	Door and window roll to reduce draft.		3.5.3
	Introduction of glass panel in doors, illumination, sunlight	3,6	
	Concrete improved door and window frames, timber saving	3,7	
testing	Concrete window frame 2 ft (wide) x 3 ft (high)		3.7.1
	Lintel construction over door or window opening	3,8	

Main category	Sub-categories	Code	Subcode
4			
Foundations	Improvement, introduction of soil retaining walls inside foundation	4,1	
Retaining walls	Construction of buttrees or cross walls to reinforce foundations		4.1.1
	Improvement, introduction of soil retaining walls outside the house in yard	4,2	
	Improvement of water drainage along foundations, dampness control	4,3	
	Construction cut-in channel for capture of surface water away from foundation		4.3.1
	Widening foundation base with ties into the existing walls	4,4	
	Cement pointing of foundation stones or blocks	4,5	
	Damp-proofing of floor inside plinth at foundation level,	4,6	
	Excavating inside floor, drain, plastic layer, new inside floor, insulation		4.6.1
	Excavating outside foundation and apply plastic sheeting.		4.6.2
	Galvanised wire-mesh reinforcement for walls	4,7	
	BACIP wire-mesh reinforcement for walls		4.7.1
	BACIP wire-mesh reinforcement for lintels		4.7.2
	BACIP 3mm galvanised wire for wall-beam anchors		4.7.3
	Reinforced concrete reinforcements in walls	4,8	
	Gabion wire mesh for riverside reinforcement	4,9	

Main category	Sub-categories	Code	Subcode
5			
Walls & Wardrobes	Reconstruction of bulging, loose or damaged walls, using wire-mesh	5,1	
	Addition of inside bearing wall with wire-mesh reinforcement		5.1.1
	Pointing of existing walls with cement mortar, inside, outside or both	5,2	
	Retrofitting existing wall construction with wire-mesh	5,3	
	Wire mesh reinforcement of corners of walls		5.3.1
	Introduction of shear walls, build-in cabinets and storage for box stabilisation	5,4	
	Construction of inside reinforced wall boxes for storage		5.4.1
	Construction of inside reinforced wall boxes for wardrobes		5.4.2
testing	Introduction of structural light, cavity walls for improved thermal insulation	5,5	
	Compacted soil block wall 4 inch thick		5.5.1
	Cement block wall 4 inch thick		5.5.2
problem	Light weight concrete panels 2 inch thick		5.5.3
	Introduction of non-structural light weight wall panelling, wattle, grass, etc	5,6	
	Wattle wall from willow branches, soil cement plaster		5.6.1
	Exp metal wire mesh on wood strips 2 x 2" (plastic) with cement plaster,		5.6.2
	Exp metal wire mesh on 3" pegs with plastic and cement plaster,		5.6.3
	Exp metal wire mesh on wood strips 2 x 2"(plastic) with soil/lime plaster,		5.6.4
	Exp metal wiremesh on pegs with plastic and soil/lime plaster		5.6.5
problem	Woodshavings and cement panels 2 inch thick		5.6.6
	Thin light weight grass/reed 'chakai' mats		5.6.9
	Painting of wall surface with light colours for better illumination and hygiene	5,7	
	Damp-proofing walls from sanitation rooms, plastic, chick-mesh, plaster	5,8	

Main category	Sub-categories	Code	Subcode
6			
Floors & Furniture	Damp-proofing of floors, living rooms and sanitation rooms,	6,1	
	Surface improvement of floors, cement, tiles	6,2	
	Thermal insulation of floors, wood, grass mats,	6,3	
	Creation of floor diaphragms, wire-mesh, plaster	6,4	
	Square folded roof profile sheets (1.5"x1.5") with concrete topping one inch		1.0.1
	Fixing or reinforcement of floor diaphragm and to tie-beam	6,5	
	Storage facilities for goods and foods	6,6	
	Bedding storage wall rack, 4 collapsable shelves		6.6.1.a
	Bedding storage wall rack, 3 collapsable shelves, for low houses		6.6.1.b
	Dress storage		6.6.2
	Shelving in existing storage rooms, reorganisation		6.6.3
	Creation of new storage room or space		6.6.4
	Stone/block/mesh-cement container on the ground		6.6.5
	Ferro-cement grain container on the ground		6.6.6
	Grain storage, plastic barrels, different sizes		6.6.7

Furniture for office and schools	6.7.
H-A frame chair several heights, wood	6.7.1.a
H-A frame chair several heights, steel tube and wood	6.7.1.b
Table two persons, several heights, chipboard, thin formica	6.7.2.a
Table two persons, several heights, MDF, normal formica	6.7.2.b
Stackable table for conference halls	6.7.2.c
School board	6.7.3
Book case/trunk with wheels, two door, metal 24 Gauge	6.7.4
Furniture for kitchens	6.8
Kitchen worktop, low, GI sheet	6.8.1.a
Kitchen worktop or school science table (high) GI sheet	6.8.1.b
Kitchen worktop, low, Stainless steel basin	6.8.2.a
Kitchen worktop or school science table, high, Stainless steel basin	6.8.2.b
Utensils cabinet, wire mesh ventilated, 30"w x 30"h x 10"d	6.8.3.a
Utensils cabinet, wire mesh ventilated, 30"w x 36"h x 10"d	6.8.3.b
Furniture for bedrooms, living room	6.9

Main category	Sub-categories	Code	Subcode
7			
Space Planning	House planning tool used for horizontal house extension	7.1	
	Cost estimate for the horizontal extension house	7.1.1	
	Reinforcement details for horizontal house extension	7.1.2	
	House planning tool used for new house planning exercise	7.2	
	Cost estimate for new house plan	7.2.1	
	Reinforcement details for the new house plan	7.2.2	
	House planning exercise for additional storey or floor	7.3	
	Cost estimate for additional storey	7.3.1	
	Reinforcement details for the additional storey	7.3.2	
	House planning exercise for cluster planning	7.4	
	Cost estimate for cluster plan	7.4.1	
	Reinforcement details for cluster plan	7.4.2	
	Redefinition and organisation of existing spaces	7.5	
	Re-organisation of entrance spaces	7.5.1	
	Re-organisation of storage spaces	7.5.2	
	Re-organisation of sanitary, bath, washing spaces	7.5.3	
	Re-organisation of kitchen and cooking spaces	7.5.4	
	Re-organisation of living, bedroom spaces	7.5.5	
Village Planning	Creation and organisation of issue specific village committees, water, roads	7.6	
	Linking communities and individuals with relevant institutions, credit, services	7.7	
	Planning for villages and village extensions	7.8	
	Provision of maps of villages and clusters	7.9	
	Provision of village sketch plan with hazard areas (1:25.000)	7.9.1	
	Provision of village scale map with indicated roads/pipes (scale 1:10.000)	7.9.2	
	Provision of detailed cluster maps (1: 500, 1:1000)	7.9.3	

Main category	Sub-categories	Code	Subcode
8			
Water & Sanitation	New separation and composting dry double vault latrine	8.1	
	Mould for the casting floor of double vault composting latrine	8.1.1	
	Ceramic separation squatting pan and steps	8.1.2	
	Drainage system vor composting toilet	8.1.3	
	Improved topslab for existing pit-latrines, squatting places	8.1.4	
	Wooden bathroom rack for on sanitation floor	8.1.5	
	Pour-flush latrines, and soak aways	8.2	
	Construction of double soaks for composting	8.2.1	
	Provision of poor-flush squatting pan	8.2.2	
	Ventilated Improved Pitlatrine	8.3	
	Improved sanitation or bathroom space and installations	8.4	
	Water storage tank, inside or outside the house	8.5	
	Frost-free communal or individual tappoints	8.6	
development	Solar heater for warm water	8.7	
	Tractor tube, frost resistant, 100 liter	8.7.1	
proposed	Water cooler for perishable products	8.8	
	Evaporation cooler, desert type	8.8.1	

Main category	Sub-categories	Code	Subcode
9			
Power & Energy	Supply of illumination, fluorescent tubes, etc	9,1	
	Installation switch box, one tube and connection		9.1.1
	Installation of tube light lamp covers, thin mesh		9.1.2
	Installation of tube light lamp covers, thick mesh		9.1.3
	Solar fruit dryer 3ft x 3 ft	9,2	
	Supply, installation of lamps or mini Solar Home Systems	9,3	
	Magic Neste solar lamp with mini solar panel		9.3.1
Nist	Base kit with 2 TL and maximum output 70-90 Wh/day		9.3.2
Nist	SHS-I with 3TL and maximum output 150-200 Wh/day		9.3.3
Nist	SHS-II with 4TL and maximum output 300-400 Wh/day		9.3.4
Nist	SHS-III with 5TL and maximum output 450-500 Wh/day		9.3.5
proposed	Supply of solar battery chargers	9,4	
	Batteries for solar battery chargers		9.4.1
proposed	Radio for reception of local radio and educational programmes	9,5	
	Supply of small generator of 650 KV, Honda	9,6	

Main category	Sub-categories	Code	Subcode
10			
Other & Tools	Cement block moulds, rack moulds	10,1	
	Standard hollow block, rack mould 8"h x 4"w x 12"l (one pair)		10.1.1
	C shaped block rack mould 8"h x 6"w x 12"l (one pair)		10.1.2
	L shaped block rack mould 8"h x 6"w x 12"l		10.1.3
	Wheel barrow	10,2	
	80 Liter, low model gauge 20 tub, handles 24" wide		10.2.1
	Earthquake shake table	10,3	
	Single board 3 ft x 3 ft		10.3.1
	Cement and concrete tester	10,4	
	BACIP water or insulation blanket	10,5	