

Q

Library
IRC International Water
and Sanitation Centre
Tel.: +31 70 30 689 80
Fax: +31 70 35 899 64

U D A Y A M

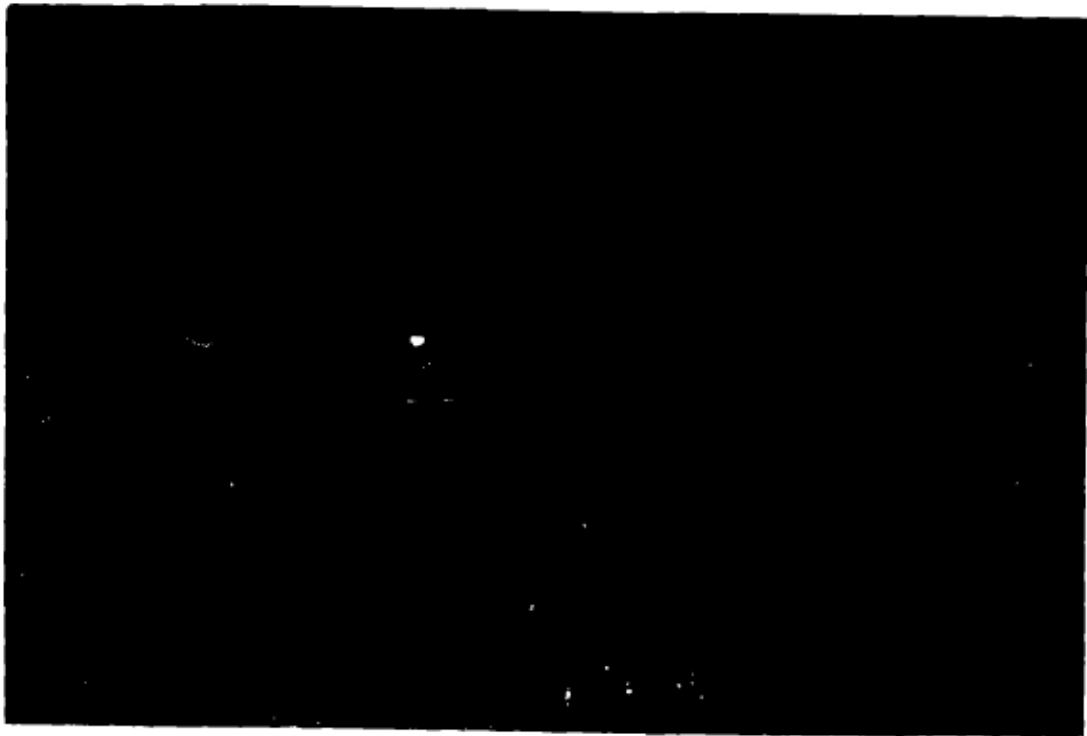

TOTAL DISTRICT SANITATION
ALLEPPY



ALLEPPEY DISTRICT

[DISTRICT COUNCIL DIVISIONS NOS 38]

SCALE 1 CM = 23 KM

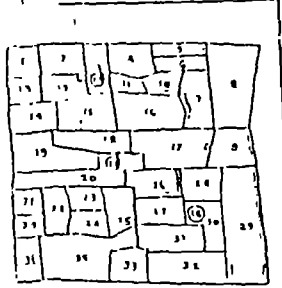
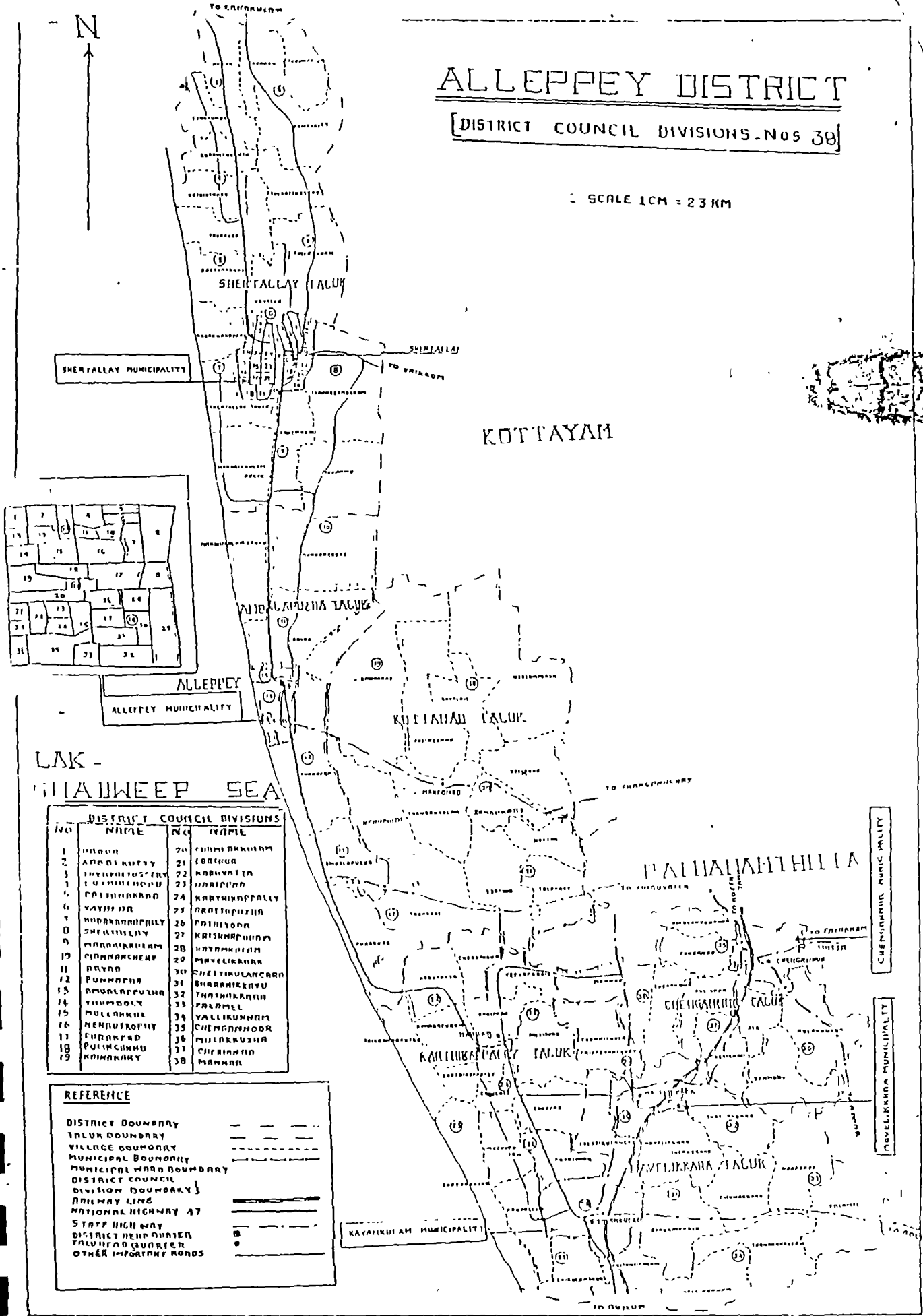

DISTRICT COUNCIL DIVISIONS			
No	NAME	No	NAME
1	ഇരൂർ	20	കുറുപ്പുപുഴ
2	അറിയൂർ	21	കുറുപ്പുപുഴ
3	കുറുപ്പുപുഴ	22	കുറുപ്പുപുഴ
4	കുറുപ്പുപുഴ	23	കുറുപ്പുപുഴ
5	കുറുപ്പുപുഴ	24	കുറുപ്പുപുഴ
6	കുറുപ്പുപുഴ	25	കുറുപ്പുപുഴ
7	കുറുപ്പുപുഴ	26	കുറുപ്പുപുഴ
8	കുറുപ്പുപുഴ	27	കുറുപ്പുപുഴ
9	കുറുപ്പുപുഴ	28	കുറുപ്പുപുഴ
10	കുറുപ്പുപുഴ	29	കുറുപ്പുപുഴ
11	കുറുപ്പുപുഴ	30	കുറുപ്പുപുഴ
12	കുറുപ്പുപുഴ	31	കുറുപ്പുപുഴ
13	കുറുപ്പുപുഴ	32	കുറുപ്പുപുഴ
14	കുറുപ്പുപുഴ	33	കുറുപ്പുപുഴ
15	കുറുപ്പുപുഴ	34	കുറുപ്പുപുഴ
16	കുറുപ്പുപുഴ	35	കുറുപ്പുപുഴ
17	കുറുപ്പുപുഴ	36	കുറുപ്പുപുഴ
18	കുറുപ്പുപുഴ	37	കുറുപ്പുപുഴ
19	കുറുപ്പുപുഴ	38	കുറുപ്പുപുഴ

REFERENCE	
DISTRICT BOUNDARY	---
TALUK BOUNDARY	---
VILLAGE BOUNDARY	---
MUNICIPAL BOUNDARY	---
MUNICIPAL WARD BOUNDARY	---
DISTRICT COUNCIL DIVISION BOUNDARY	---
PRINCIPAL LINE	---
NATIONAL HIGHWAY 47	---
STATE HIGHWAY	---
DISTRICT HEADQUARTERS	⊙
TALUK HEADQUARTERS	⊙
OTHER IMPORTANT ROADS	---

PREPARED BY KARTHIKEYAN KK

1



CONTENTS

1. Introduction
2. Project Area
3. Identification of problem
4. Longterm Objectives & Immediate objectives
5. Components of sanitation facilities activities to overcome
6. Special significance offered for household sanitation
7. Design and estimate
8. Role of students for a sanitation movement in Kerala
9. Implementation mechanism
10. Organogram
11. Towards building a mass movement
12. IEC Plan of action

Tables

1. Panchayatwise sanitation data
2. Household latrine Panchayat and Municipality
3. Panchayatwise environmental sanitation Proposed units for construction and improvement

Budget

1. Budget allocation - Household sanitation Panchayat level and Municipalities
2. Above povertyline contribution pattern
3. Environment sanitation
4. Institution latrine
5. Production centre
6. IEC activity
7. Project estimate
8. Project estimate yearwise
- "

LIBRARY IRC
PO Box 93190, 2509 AD THE HAGUE
Tel.: +31 70 30 689 80
Fax: +31 70 35 899 64
BARCODE: 13765
LO: S22 INKE97



TOTAL SANITATION PROGRAMME - ALAPPUZHA DISTRICT

INTRODUCTION

If performance in education and communication is any indicator Kerala stands prominently among Indian states in the matter of development. But the state of its environmental sanitation badly leaves many things to be desired. Kerala is a land of paradoxes and such poor coverage in sanitation (30%) in a highly literate state is one of them!

The present statistics on household sanitation says that there are about 26 lakhs household without latrine, which is an enormous figure to be tackled. It is estimated that only around 25000 latrines are constructed every year by all the agencies involved. When we consider the number of new houses built each year (population increase) we come to a startling understanding that this will not even catch up with the population.

This scenario calls forth for a new approach in the sector by which the activity is spread rather fast by appropriate planning. The new Panchayati Raj structure actually offers an opportunity in this regard. It is only through strengthening the local governing bodies to take up responsibilities in creating local capacities and mobilising local resources that a programme of such massive dimension could ever become a reality.

Community as a whole has to be reoriented to take up this challenge and this is possible only through dedicated and systematic awareness building and health promotion activities. The gravity of the problem has to be recognized both by community and local governing bodies alongwith taking initiatives in shouldering their share of responsibilities.

The lessons learned and structure created in peoples planning for 9th plan (Janakeeyasootranam) could be functionally utilised towards this. All peoples forums which in the past had proved its utility to carry out peoples programme should be brought together in the programme.

A total sanitation programme must also view the concept in its broadest term which include, in addition to latrines, arrangements of solid waste management, drainage, soakpit and the like. It should also include a whole package of water related health promotion initiatives like keeping the surroundings of drinking water sources (well, pond, tap etc) clean and tidy.



It would also be very important to take local peculiarities in consideration before finalising the options and modes of facilities to be included in the programme. Alapppy district is one place with a variety of such peculiarities and a proposal for its total sanitation would be taking sufficient consideration in this regard.

I. Project Area

1.1 General features

Alappuzha, the smallest district of Kerala state, came into existence on 18th July 1957 and was carved out of neighbouring districts of Kollam and Kottayam. Nature has endowed this district with a wealth of watershed. The canals, rivers and backwaters afford an easy and clean mode of transportation in this district.

The total area of the district is 1414 sq.km. It lies between North latitudes 9.05' and 9.52' and East longitudes 76.17' and 76.48'.

The entire area can be divided into two natural divisions viz. the low and mid land. Cherthala, Ambalappuzha, Kuttanad and Karthikappally taluks lie entirely in low land region where as Chengannur and Mavelikkara taluks lie in midland regions. The low land bordering the sea coast covers an area of 1193.53 sq.km and the remaining area comes under mid land region. This is the only district in Kerala having no western ghat in the east and thus there is no high land divisions and forest. The flat and unbroken sea coast covers 81.7km in length.

1.2 Demographic and occupational features

The total population in the district as per 1991 census is 2001217 including both rural and urban. Having only 3.64% of the area of the state it bears 6.86% of the total population. The pressure of population on this small strip of land is too high as the figures of the density of population reveals. The density of population in this district is almost double of the state figures.



Occupational Profile of Alappuzha District

<u>Sl.No.</u>	<u>Occupation</u>	<u>Number</u>	<u>%</u>
1.	Cultivators	48009	7.97
2.	Agricultural labourers	145641	24.17
3.	Livestock, fishing forestry	48145	7.99
4.	Mining & Quarrying	2745	0.46
5.	Household Industry	55568	9.72
6.	Manufacturing	77963	12.94
7.	Construction	19956	3.99
8.	Trade & Commerce	66649	11.06
9.	Transport, Storage communicatin	34287	5.69
10.	Other services	96492	16.01
	Total	602604	100.00

Source : Census of India 1991, State - District Primary census abstract

Main occupation of the people in this district is agriculture and the major area of cultivation comes in Kuttanad and Onattukara region. The main crops are paddy and coconut.

Fishing is another main occupation of the people. About 156592 persons are employed in this activity, of which 100532 are in the marine sector and 56060 in the inland sector.

The total number of households in the rural area comes to 322985 and rural population comes to 1631798. Out of the total number of 322985 rural households 154552 families are living below the poverty line.

The total number of households in urban area comes to 74683.



II. Identification of problem

2.1 Peculiar topography and special problems of sanitation

The district of Alappuzha is not just another district of Kerala, but one with its topography so different from all others as to make it entirely unique. Any intervention here to improve its environmental sanitation would have to keep this in mind.

The once beautiful member of canals which were actually functional in making the town famous the world over as the **Venice of the East** is sadly the most dangerous now from sanitation point of view and also a most unaesthetic site for that matter as it has virtually become the disposal ground of all sort of garbages and dirt of the town including human excreta. The left overs of hotels and slaughter houses dead animals heaps of plastic wastes all these make it unbelievably unhygienic.

Kuttanad known as the granery of Kerala with its rustic and politically progressive community is now under constant threat of epidemics. It had happened recently with Japan fever and cholera killing more than 30 which is actually a shame for a state priding themselves as most literate state in India.

The problem emanates from two causes; one from the over use of chemical fertilisers and pesticides and the other lack of adequate sanitary facilities. The intermittent floods which is gripping the area repeatedly each year make an added dimension to the whole thing because during floods most of the land area submerges and water level reach up to the floor levels of most houses. Naturally safe drinking water and safe disposal of excreta become problematic. And the flood stays for days and many a time people are forced to evacuate to safer places. The situation of solid waste management generally is very bad with all manner of things being thrown to the rivers and canals by people, and the point is here, unlike other regions, it is the river water people depend for even drinking.



The water quality monitoring carried out by the Kuttanad water balance study put the levels of faecal bacteria in the water as ten times higher than the promissable level. This creates serious drinking water problem as many people it is said, are forced to consume river and canal water ever for drinking purpose in certain months of the year.

The most popular type of latrine used by people especially in Kuttanad area are the so called canal latrines. There are latrines built on the bank of river and canal usually with thatched enclosures (for privacy) but without any provision to contain excreta from falling into water. This means potentially dangerous faecal matter goes straight into water to make it polluted. Naturally all these thousands of latrine in Alleppey district may have to be demolished and substitute with safe latrines with community participation.

The consequences of sedimented chemical fertilizers and pesticides in the water especially in Kuttanad are also said to be one of the reasons for the recurring strange diseases in these localities. So only a comprehensive approach to tackle both drinking water and sanitation problems would alone provide solutions to the peculiar situation prevailing in the area.

Howsoever much we may succeed in constructing units of latrines to all those without such facilities, these are going to be only partial interventions if initiatives are also not taken to tackle the massive problems related to criss-crossing canals and rivers of Alleppey along with it.

The conditions of the canals around Alapetty town requires special measures in itself to make significant improvements. For the total sanitation of Alapetty this is actually inevitable and must be really an emphasis as without if any intervention would only be partial. A separate project formulation for this is necessary in case the present programme for same reasons is not able to do justice to it.



2.2 Diarrhoeal diseases

Diarrhoeal diseases still constitute one of the major causes of morbidity in Alappuzha especially in children below 5 years of age. Mortality from diarrhoea is low mainly due to better health care and better awareness of the dangers of diarrhoea. Kuttanad area being water logged, for most of the year, suffers from lack of drinking water and sanitation facilities and consequently high incidence of diarrhoeal diseases in this area. In coastal areas also the situation is not different. High rate of contamination of surface water with faecal bacteria is the common problem.

The environmental and sanitary situation in Alappuzha district is really inadequate.. In the case of latrines it is estimated that approximately 60% of the rural population have no latrines. In the case of urban areas population with out sanitary latrines is 15.62%.

Number of diarrhoeal cases reported in various Primary Health Centres in the district for the last three years is as follows.

<u>Year</u>	<u>Total cases reported</u>	<u>Death cases</u>
1994	75364	-
1995	82459	-
1996	87814	34

Majority of the cases are reported from the coastal areas and Kuttanad region. The number of diarrhoeal cases reported in private hospitals may be higher than the above PHC data since there are also large number of private hospitals spread all over the district.

There are 72 panchayats and 12 blocks in Alappuzha district in addition to 5 municipalities.

The proposed project area consists of all the 12 blocks in the district as well as the 5 municipalities. The blocks are either at coastal areas or water logged. In the case of the 5 municipalities also the situation is not different. In Alappuzha district the high density population and lack of sanitary latrine facility and non



availability of free land make the environmental sanitation condition worse. Since majority of the households belong to lower income groups their income is too low to have the basic facilities. As one expert puts it since an overwhelming proportion of families are defecating in the open air, that too is the very close premises of their residential areas, it gives scope for the spread of contagious diseases such as typhoid and cholera which are found to be the main killers of infants and children. The infant mortality rate (IMR) in the fishing communities is 123 compared with the Kerala average of 32. From the above stated problems it is evident that drinking water and sanitation sector in the coastal areas and water logged areas of Alleppey district require high priority.

The only way to help them to come out of this extremely vulnerable and deplorable condition is to have provision of sanitary latrines and safe drinking water which in turn provides better health, better wage earning capacity and thus improved standard of living.

III

3.1 Long term objective

The long term objective of the programme is to improve the health and living conditions of people.

3.2. Immediate objectives

- 3.2.1 To help build affordable and sustainable sanitation facilities for Households, Institutions and community
- 3.2.2 To raise awareness of community and panchayat raj institutions about the gravity of environmental sanitation situation prevailing and the need to shoulder their share of responsibilities towards overcoming them.
- 3.2.3 To enhance and strengthen the capacity of Panchayat Raj institution and orient departments and NGOs to plan, implement and manage the programme with community participation.

9



IV

Components of Sanitation Facilities

- Proper handling of water
- Proper drainage for standpost and wells
 - Clean surrounding of Standpost and well is water sources
 - Cover drinking water and use a laddle for taking water or tilt the pot
 - Avoid contact of hands with water
 - Closing of undeserving taps
 - Leak reporting system panchayath level
 - A team of trained plumbers for two panchayats for O & M
- Human excreta disposal
- Build household latrines
 - Institutional latrines
 - Pay & use latrines
 - Proper use and maintenance of latrine
 - Wash hands with soap after defecation
 - Each latrine should provide facility to keep soap
 - Avoid canal latrines
 - Under 5 children excreta should be handled properly
 - Coastal area make sure both men and women are using latrines
 - There should be brush, a bucket with water and mug inside the latrine
 - Waterseal should be clean
 - Legal steps - each new house should have a latrine



- Solid waste disposal
- Production of compost from waste and make it into an economical programme or use it for agriculture purpose and vegetable garden
 - Vermiculture / pith compost
 - Biogas, plastic waste management
- Waste water disposal
- Each house / institution should have proper drainage for waste water from kitchen and bathroom
 - There should be platform for cleaning utensils
 - Soak pits for household
- Personnel hygiene / Home hygiene
- Each home should have a compost pit, soak pit
 - Proper fencing
 - Plant new trees
 - Wash hands before taking food
 - Wash hands after defecation and also after cleaning under 5 children
 - Food sold in market places and near schols, busstand petty shop - should properly be covered, avoid flies
 - Do not urinate in public places



Home Sanitation

- Each household should own latrine
- One compost pit / soakpit
pith compost / vegetable garden
- Proper drainages for kitchen and bath room
- Proper use of facilities by both men and women
- No faecal particles around home
- Proper drainage around home
- Kitchen very clean
- Water kept clean
- General Cleanliness

Village Sanitation

- All Institution must have clean latrine
- Compost pit for each institution
- No stagnant water, proper drainage
- Clean Market places
- All facilities must function well
- Proper monitoring of facilities
- Clean roads
- Each panchayat should have one model colony.
- Each and every member of the village should know his/her duties and role to keep his/her village clean
- News boards / hoardings in each panchayath
- Proper solid waste management system

12



Special significance of options offered for HH Sanitation

The high watertable and recurring floods in the area poses problems in deciding the right option for sanitation. Naturally any type of septic tank is going to be too costly option for the majority poor community of Alappuzha. The practical option may be an improved version of low cost pour flush double pit latrine. The improvement has to mainly focus on raising the pit and basement to an optimum level necessary, considering the highest water level during rainy season. Ofcourse raising is costly but it is inevitable. The pilot study (R & D) conducted by SEU-F in Kuttanad suggest that 50-70 cm raising of basement would be sufficient to work even during normal floods. It may not be practical to raise level beyond this anticipating once-in-a-while big floods considering the cost etc. Also, when such floods occur naturally the inmates of households are forced to move away to safer places.

It is advisable that some practical precaution is taken for the big floods. A pressing need during such events is to have some provision to close the closet tight so that excreta within the pits won't splash out through closet mouth. Otherwise, the aftermath of such floods would be so unhygienic and dangerous. This is especially so as the programme is going to construct thousands of latrines.

Considering all related matters, the following types of units for household latrine are envisaged subject to certain improvements.

	<u>Cost</u>	
	<u>Normal</u>	<u>Waterlogged</u>
	Rs.	Rs.
Superstructure & both pits	3,350	3,600
Superstructure & both pits	2,800	3,000
Without superstructure		
(plinth level) & both pits	2,000	2,450
Without superstructure		
(plinth level) & one pit	1,800	2,000



Cost sharing of subsidy pattern

1. The underlying factors behind the approach of cost sharing are two:
 - a. to install a feeling of ownership among community and PR institutes for the facilities.
 - b. to support the scarce resource available with the government for development activities.

2. Keeping the above in mind the following general pattern of sharing is possible.

- beneficiaries	25%
- PR institutions)	
- state government)	45%
- central government)	
- possible external assistance	30%

3. The actual amount to be paid would depend on the kind of options the programme is going to adopt. This decision will take into consideration the terrain condition on the one hand and possibly the socio-economic status of beneficiaries. For instance, in case of poorest of the poor beneficiaries the concerned panchayat may have to subsidise them to some extent.

Again, say, if option no.4 (mentioned in the last section) is adopted, the beneficiary may have to pay more than 25% because the responsibility of completing the unit will naturally fall on him/her.

4. There would not be any free facilities as such envisaged in the programme.

5. Those who are above poverty line and without latrine would only get the cover of health promotin activities of the programme; but for owning a latrine they will have to pay the full cost for indicating them in the programme.



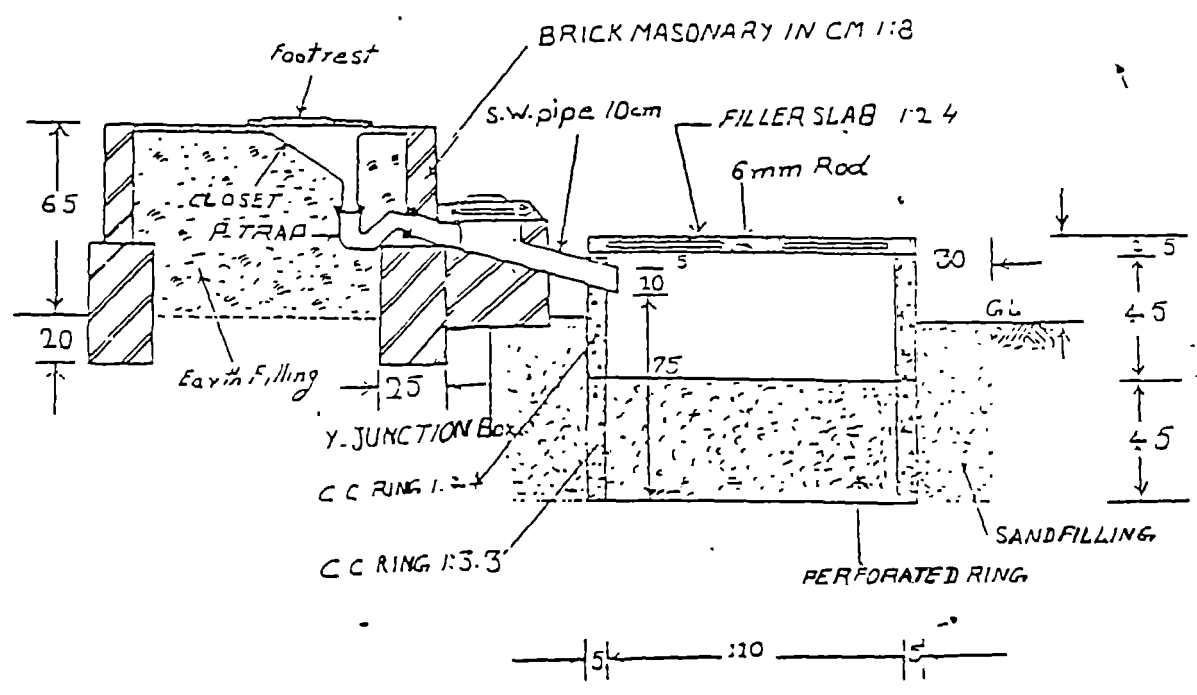
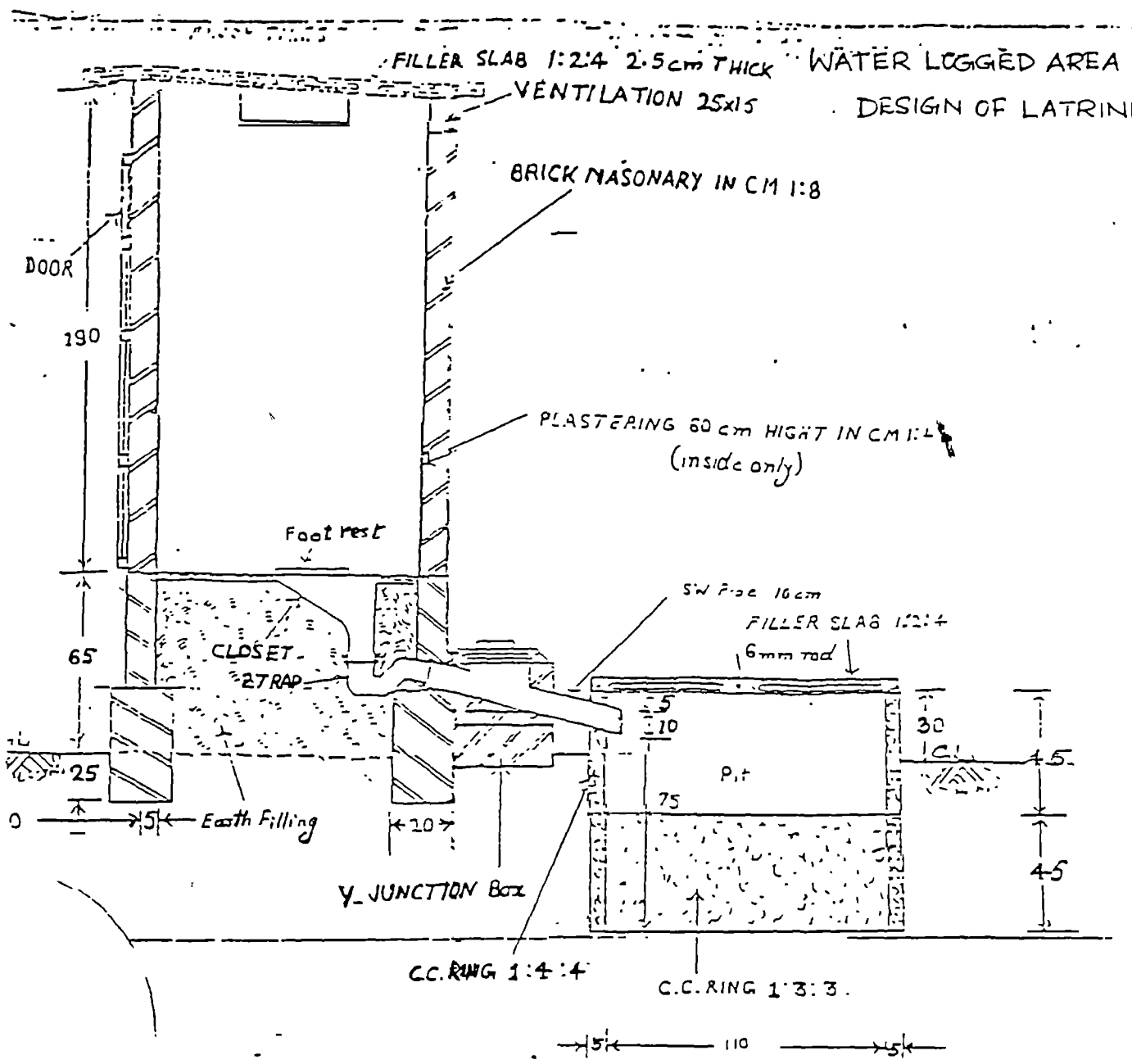

5



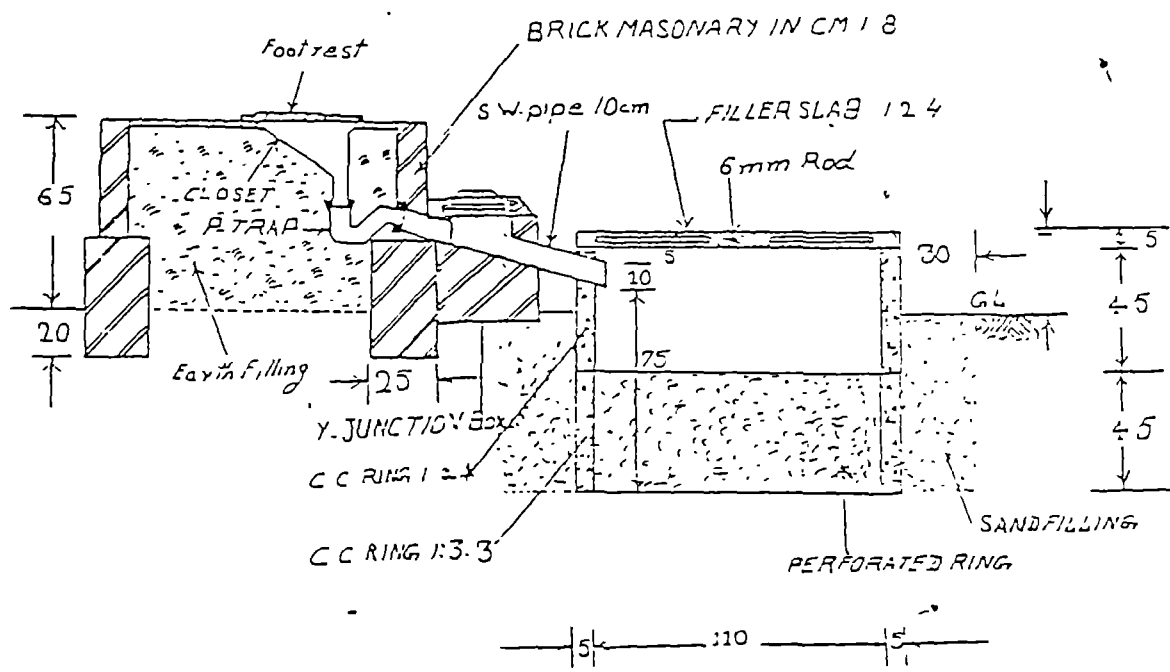
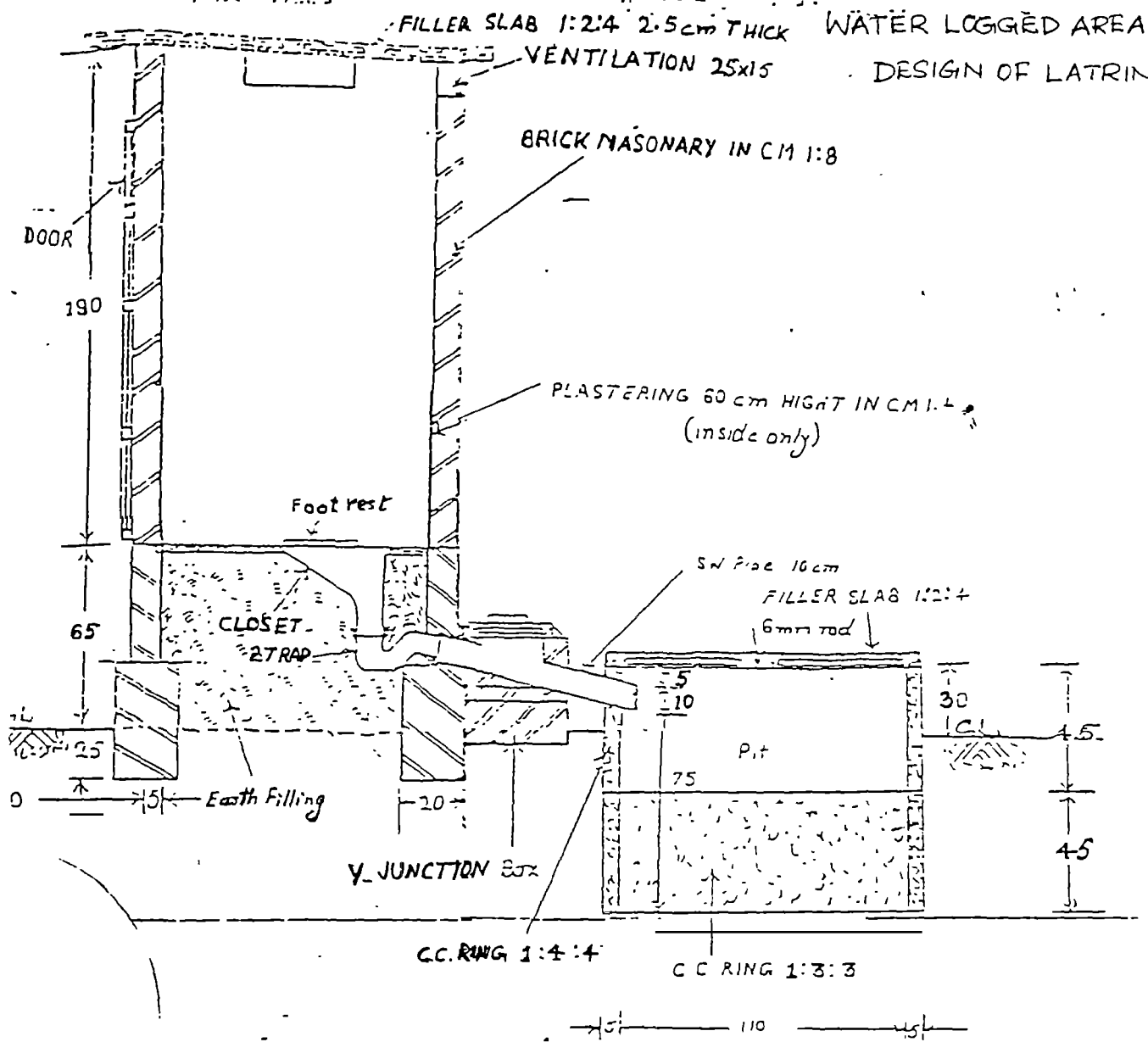



PLAN OF LOW COST SANITATION UNIT (PLINTH LEVEL)

WATER LOGGED AREA

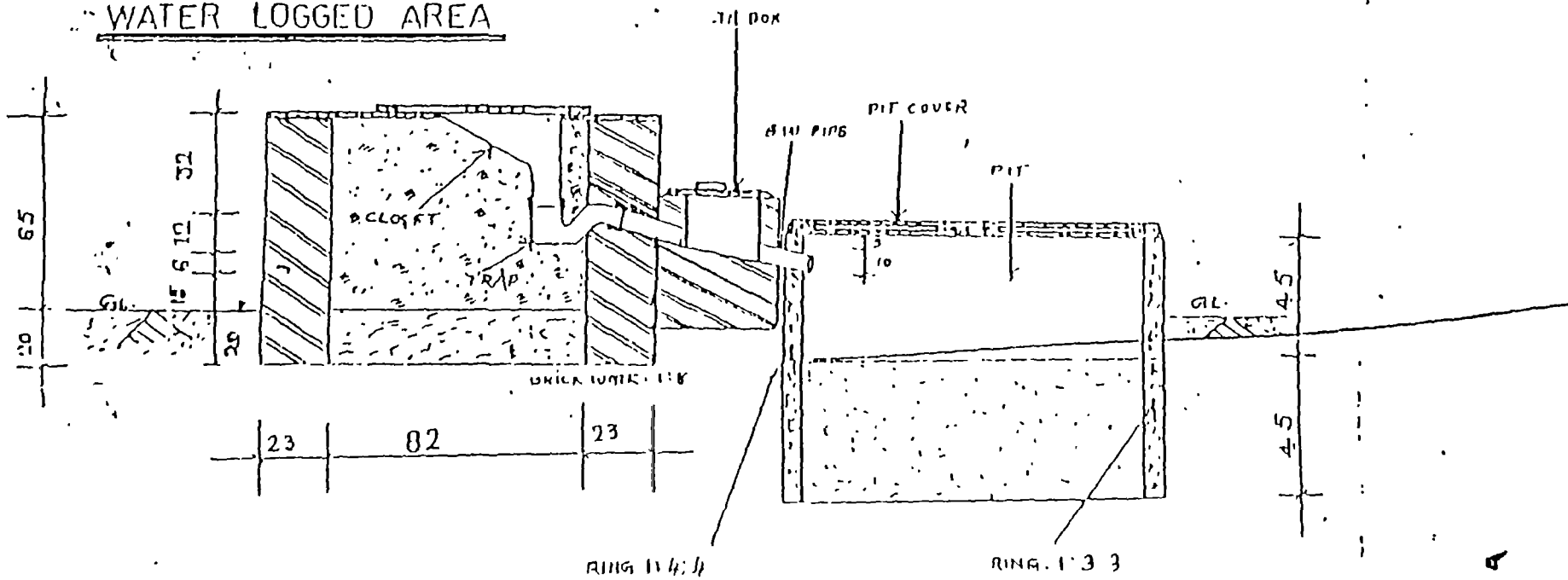

A



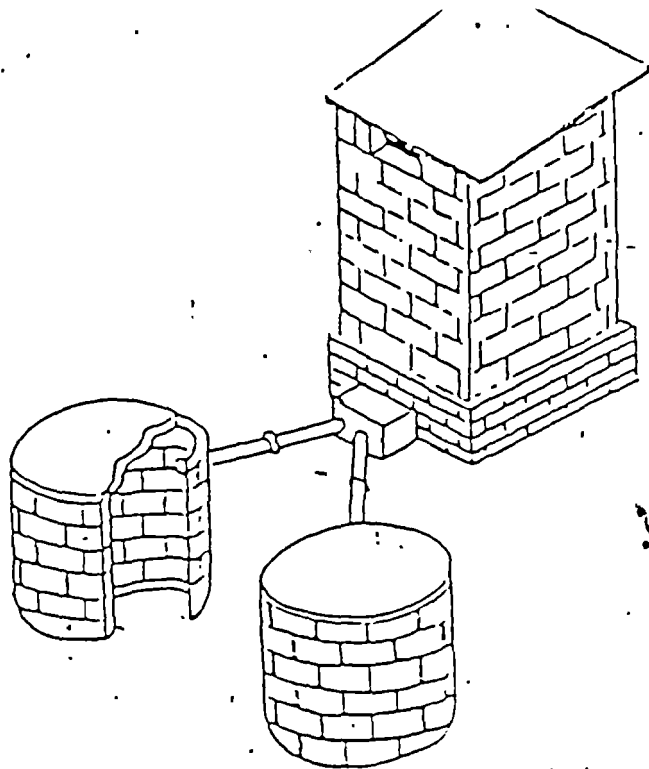

TWIN PIT LATRINE WITH SUPERSTRUCTURE (CEMENT SAND BRICKS)

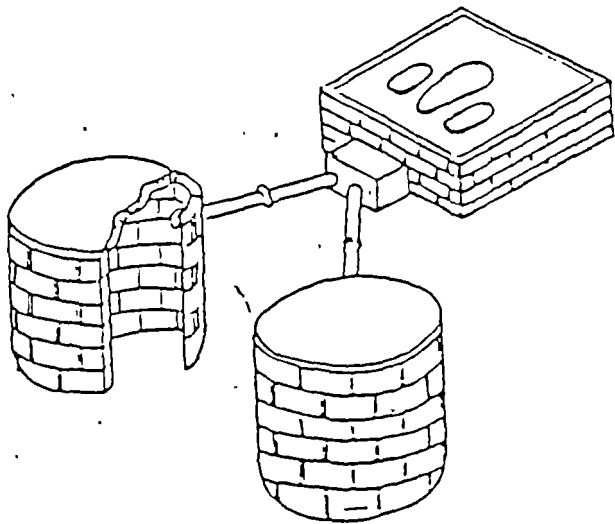

TWIN PIT LATRINE WITHOUT SUPERSTRUCTURE (CEMENT SAND BRICKS)

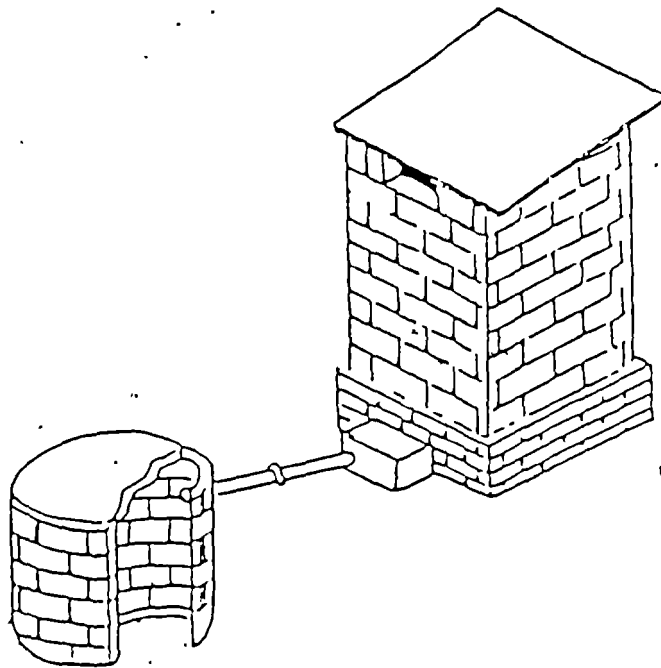

SINGLE PIT LATRINE WITH SUPERSTRUCTURE (CEMENT SAND BRICKS)



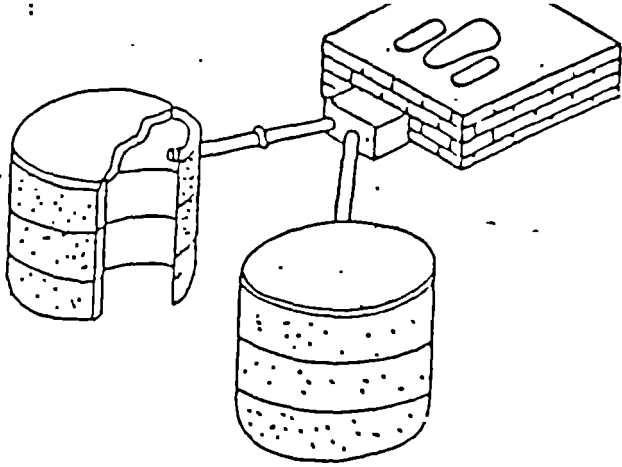

TWIN PIPE LATRINE WITHOUT SUPERSTRUCTURE (RAKE CEMENT CONCRETE RINGS)

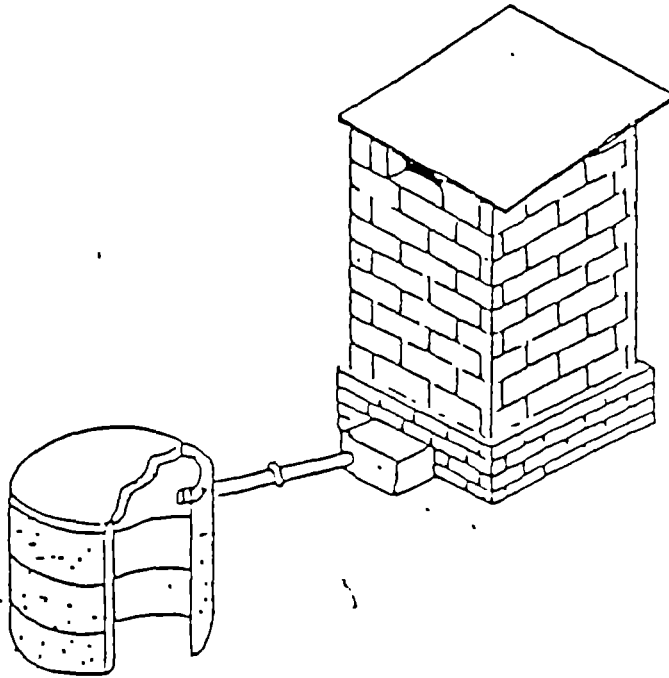

SINGLE PIPE LATRINE WITH SUPERSTRUCTURE (RAKE CEMENT CONCRETE RINGS)

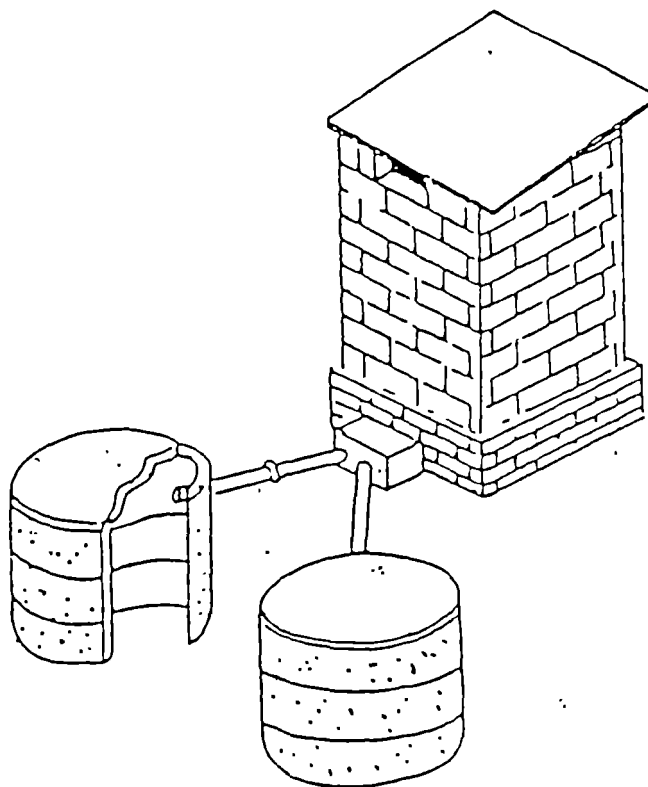

TWIN PIPE LATRINE WITH SUPERSTRUCTURE (RAKE CEMENT CONCRETE RINGS)



PLAN OF THE L.V. NO. S. STATION UNIT

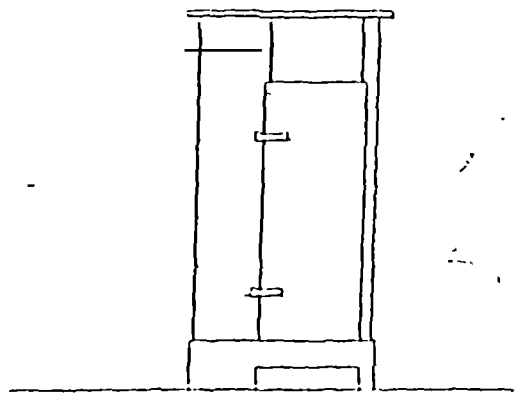

Front elevation

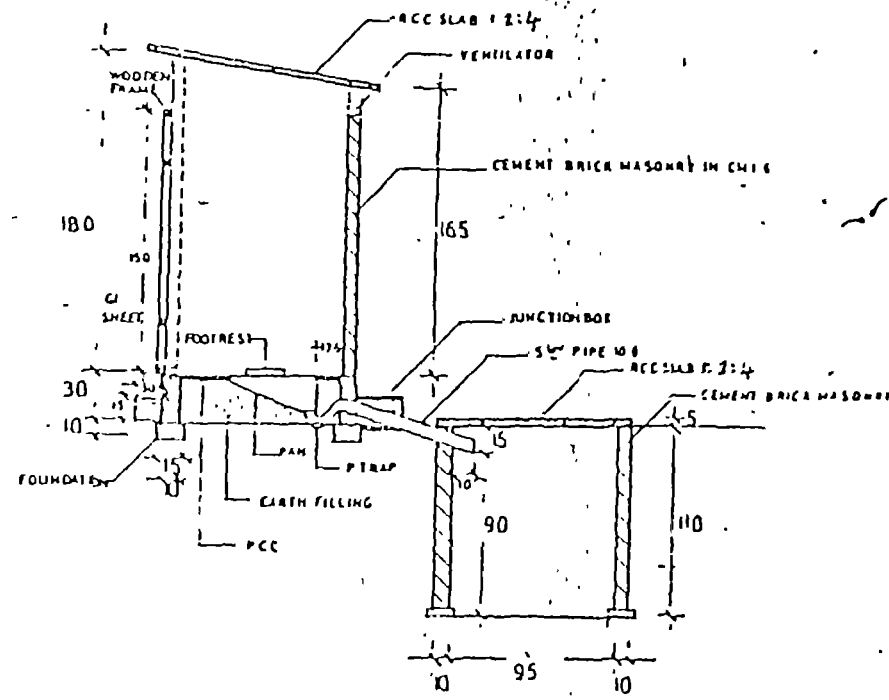

section on Z-Z

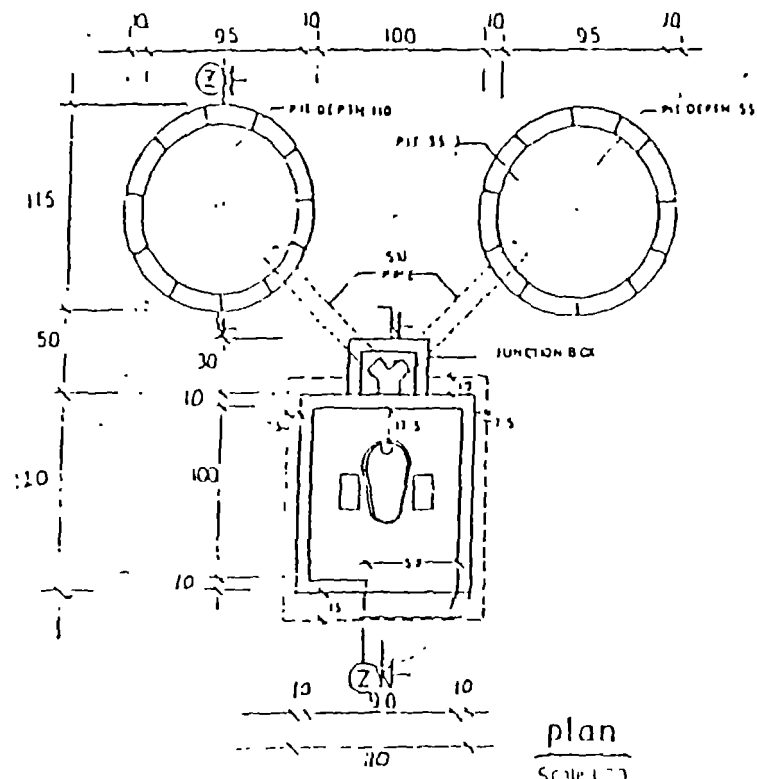

plan

Scale: 1/20

Reinforcement Details
PIT COVER SLAB (two nos) 6mm φ 110 dia

BAR LENGTH IN CM	NO OF PIECES	TOTAL LENGTH
108	4	
100	8	1972
80	8	

Roof slab 6mm φ		
142	6	
122	6	1584

20



COST OF PLINTH LEVEL LATRINE - WATER LOGGED

Bricks	350 nos.	1500 / 1000	525.00
Cement	1 1/2 bag	185 / bag	370.00
Sand	40 pan	4 / pan	160.00
SW pipe	3 nos.	16 / one	49.00
MS Rode	5 kg.	18 / kg	90.00
MS wire	50 gms		3.00
Closset 8"P trap	1 set	20 / one	200.00
Roof tiles	13 nos.	2 / one	26.00
3/4" metal	7 pan	8 / pan	56.00
Closset cover	1 no.	60 / one	60.00
Glass piece	1 no.		3.00
1 set			660.00
Labour charge			210.00
Miscellaneous			15.00

			2427.00
			=====

21



Cost of Single / Ordinary Pit Latrine

Bricks	825	1500 / 1000	1237.50
Cement	2 packet	180 / pack	360.00
Sand	50 pan	5 / pan	250.00
SW pipe	2 nos.	16 / one	32.00
Flooring tiles	21 nos.	2.20 / one	46.00
Roof tiles	6 nos.	1.8 / one	10.80
6 mm Rode	5 kg	18 / kg	90.00
MS wire	100 gm		3.00
3/4" metal	2 pan	8 / pan	16.00
1/4" metal	2 pan	8 / pan	16.00
Closet & "P" trap	1 set	200	200.00
Door & fittings	1 no.		200.00
Clamp	2 nos.		10.00
Mason Labour			300.00

			2798.30
			=====

COST OF SINGLE PIT LATRINE - WATER LOGGED

Bricks	650 nos.	1500 / 1000	975.00
Sand	50 pan	5 / pan	250.00
Cement	2 1/2 packet	180 / pan	450.00
Rings	2 nos.	16 / one	32.00
6 mm MS rode	6 kg	18 / kg	108.00
Floor tiles	21 nos.	2.20 / one	46.20
Roof tiles	8 ns.	1.8 / one	14.40
3/4" metal	3 pan	8 / pan	24.00
1/4" metal	2 pan	8 / pan	16.00
Closet & "P" trap	1 set	200 / one	200.00
Door with fitting	1 no.		200.00
Clamp	2 nos.		10.00
MS wire	50 gms		2.00
Mason & Labour			325.00

			3052.60
			=====

22



COST OF DOUBLE PIT LATRINE - ORDINARY

Bricks	1000 nos.	1500.00
Cement	2 1/2bag ISI	462.50
Sand	60 pan	300.00
SW pipe	3 nos.	45.00
Flooring tiles	21 nos.	46.20
Roof tiles	12 nos.	21.60
6 mm Rode	7 kg	126.00
MS.Wire	100 gm	3.00
3/4" metal	5 pan	50.00
1/4 metal	2 pan	20.00
Closet 8"p"trap	1 set	200.00
Glass piece	1 no.	3.00
Door & fittings	1	200.00
Clamp	2 nos.	10.00
Mason & Labour	30	350.00

3337.30

=====

COST OF DOUBLE PIT LATRINE - WATER LOGGED AREA

Bricks	650 nos.	1550/1000	975.00
Sand	50 pan	155 / pan	250.00
Cement	2 1/2 bag	180 / bag	450.00
Rings (with hole)	4 nos.	200 / one	800.00
SW pipe	3 nos.	16 / one	49.00
6 mm MS rode	8 kg	18 / kg	144.00
Floor tiles	21 nos.	2.20 / one	46.20
Roof tiles	14 nos.	1.8 / one	25.20
3/4" metal	6 pan	8 / pan	48.00
1/4" metal	2 pan	8 / pan	16.00
Closet & "P"trap	1 set	200 / set	200.00
Door with fittings	1	200 / one	200.00
Clamp	2 nos.		10.00
Glass Piece	1 no.		3.00
Mason & Labour			375.00

3591.40

=====

23



COST OF DOUBLE PIT LATRINE - ORDINARY

Bricks	1000 nos.	1500.00
Cement	2 1/2 bag ISI	462.50
Sand	60 pan	300.00
SW pipe	3 nos.	45.00
Flooring tiles	21 nos.	46.20
Roof tiles	12 nos.	21.60
6 mm Rode	7 kg	126.00
MS.Wire	100 gm	3.00
3/4" metal	5 pan	50.00
1/4 metal	2 pan	20.00
Closet 8"p"trap	1 set	200.00
Glass piece	1 no.	3.00
Door & fittings	1	200.00
Clamp	2 nos.	10.00
Mason & Labour	30	350.00

3337.30
=====

COST OF DOUBLE PIT LATRINE - WATER LOGGED AREA

Bricks	650 nos.	1550/1000	975.00
Sand	50 pan	155 / pan	250.00
Cement	2 1/2 bag	180 / bag	450.00
Rings (with hole)	4 nos.	200 / one	800.00
SW pipe	3 nos.	16 / one	49.00
6 mm MS rode	8 kg	18 / kg	144.00
Floor tiles	21 nos.	2.20 / one	46.20
Roof tiles	14 nos.	1.8 / one	25.20
3/4" metal	6 pan	8 / pan	48.00
1/4" metal	2 pan	8 / pan	16.00
Closet & "P"trap	1 set	200 / set	200.00
Door with fittings	1	200 / one	200.00
Clamp	2 nos.		10.00
Glass Piece	1 no.		3.00
Mason & Labour			375.00

3591.40
=====

2A

The Role of students for a sanitation movement in Kerala

A Cleaner Kerala programme which envisages total sanitation and hygiene conditions can achieve its objectives only if these are carried out as a social movement some what like the literacy movement. Ofcourse students as such were not having a prominent role in the literacy movement as the success of it was the dedicated and concerted effort of other people's form supported by the state. But one can legitimately hope that the participation of educational institutions could take Cleaner Kerala movement a long way ahead in terms of success. We have already some examples coming from the state of Andhrapradesh with regard to the positive roles and responsibilities taken up by the students of the state in its developmental initiatives especially among the rural population.

The participation of students in total sanitation programme of Kerala will certainly serve two important purposes.

1. Trained student forums will be able to share substantial part of responsibilities for general mobilization of the community.
2. Consequently, a whole new generation of the state is going to attain enhanced awareness about the gravity of the problem of environmental sanitation.

Towards the above, the following steps may be taken:

1. A circular by the concerned ministry/department about the programme informing of the possible roles of the student population for the total sanitation movement.
2. Initiating formulation of School Health Clubs in all the schools in Kerala.
3. Each SHC taking up an area (Ward/Panchayat) as its responsibility (awareness building and mobilization)
4. Systematic training for selected teachers (responsible for SHC) and student leaders.
5. A creative interaction between School Health Clubs and PR structures especially Gramapanchayat and Gramasabhas.

6. Delegation of special responsibility to these clubs for the dissemination of hygiene messages through cultural media.
7. Possible recognition of the commitment of students by appropriate methods including grace marks.
8. To include sanitation as thrust area during the Cleaner Kerala years (at least 5 years) in the activities of N.S.S, N.C.C., Scout, Environment Club etc.

Objectives of SHC Programme

- to stimulate and increase the awareness of children n improved hygiene and behavioural practices related to the use, handling and collection of water, safe disposal and handling of excreta and waste and good personal hygiene habits;
- to increase the awareness of pupils about the value of water, water conservation, managaement and other associated factors;
- to influence the other family members and ultimately the community by popularising healthy habits in personal hygiene and environmental sanitation;
- to educate them about the hazards of gastro-enteritis and other water-borne diseases, and the need to use sanitary latrines; and
- to make them aware of the fact that the health of a person is the health and wealth of the family and society.

Integrating this component in the activities of total sanitation movement will certainly create **A NEW MODEL OF STUDENTS PARTICIPATION IN THE SUCCESS OF A DEVELOPMENTAL PROGRAMME** to the credit of Kerala among Indian states.

26



IMPLEMENTATION MECHANISM

CONSTITUTION OF DISTRICT SANITATION MISSION (250 Members) District Planning Committee President (Chairman) District Collector (Director) All Mps, MLAs, of the District. All District Panchayat committee members. All Block/Grama Panchayat presidents DRDA Project Officer, ADC, District Panchayat Officer, DMO, Ex Engineers PWD, KWA, Deputy director Education. District Panchayat Secretaries, Representatives of Socio Economic Unit Foundation, Nirmithu Kendra, Matsyafed, NABARD, Banks, (Sheduled & Co-operative), Coir Board, Rubber Board, Plantation Corporation, Various Clubs, Organisation, NGO's Political Party Representatives	ROLES AND DUTIES. <ul style="list-style-type: none"> ▶ General Policy making ▶ Organising funds, ▶ Organising and phasing construction and IEC activities (Meeting-once in six months)
PROJECT MONITORING COMMITTEE (30 members) District Collector (director), District Panchayat President (Chairman), MPs' representative of MLAs' (4) Block Panchayat Presidents, District Panchayaths members and Grama panchayat Presidents(5) DRDA-PO, ADC, Dy Director Panchayaths DMO, Representative of SEU(F) One representative of Banks, 2 representative of NGO's 2 representative of boards/Corporation etc .	<ul style="list-style-type: none"> ▶ PMC will be the Executive committee of District Sanitation Mission ▶ Manage, administer the sanitation activities Monitor Supervise, Evaluate the Programme Periodical supervision Overall responsible for the programme (Meeting once in 2 months) <p style="text-align: right;"><i>- Management & Jan take Newslite Centre</i></p>
BLOCK SANITATION COMMITTEE Block Panchayat President (Chairman) BDO (secretary) MLAs, MPs represents Block, Block panchayat members grama panchayat presidents, representative Government departments, NGO's Clubs etc .	<ul style="list-style-type: none"> ▶ Block level managing and monitoring ▶ periodic supervision ▶ Direct supervision of DRDA funded programme
PANCHAYAT LEVEL TASK FORCE Panchayat President (Convenor) Panchayat Members, Panchayat Secretaries, Representative of NGO's and partner implementing agencies	<ul style="list-style-type: none"> ▶ Manage, Administer sanitation programme in panchayat ▶ Direct implementation of panchayat funded sanitation programme ▶ Supervision of programmes implemented by NGO's ▶ Periodic meetings of implements partner agencies and evaluate the programme ▶ Monitoring latrines for use and maintenance

Sanitation Committee Centre



5

BLOCK SANITATION RESOURCE CENTRE

This will be the central platform through which all activities related to concentrate and health promotion are carried out. This structure is to strengthen local level self reliance for the sustainability of the programme.

-2 representative from Ward sanitation committee from each panchayath

- To give training to HPT in panchayath

Representative from Grama Pt., Block, (2 each)

- Management of health promotion materials

Representative from Health department (2)

- Support technical training to masons

Representative of SEU(F)(1)

- Monitoring of latrine

Representative of VEO (2)

- Support selling up of sanitation mart of production centre



ORGANOGRAM FOR PROPOSED TOTAL SANITATION PROGRAMME ACTIVITIES

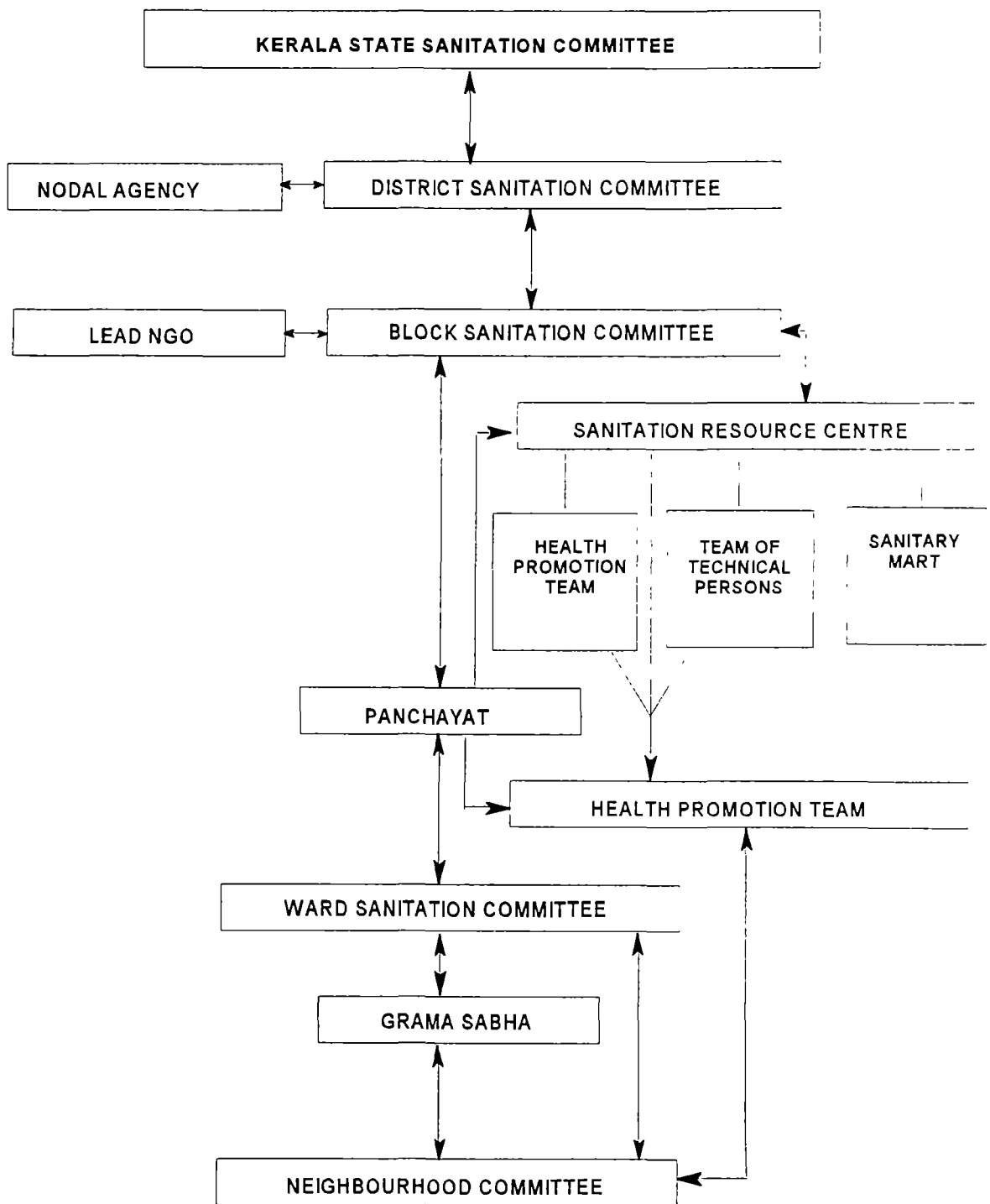



TOWARDS BUILDING A MASS MOVEMENT

1. To utilize the cultural wing which supported people's planning campaign
2. To support campaign through cine actors (TV)
3. Bring together political leaders of various parties on a common platform for announcing the programme (TV)
4. Public interest fillers with hygiene promotion messages in Doordarshan sponsored by product advertisers (make it mandatory in agreement)
5. Public interest propaganda (full page) in leading dailies
6. Slides and Newsreels based on the programmes in all cinema theatres periodically.
7. To make sanitation programme an important theme frequently in "Prabhathabheri" in AIR.
8. Organize "Koottayottam" by student community.
9. Special lotteries dedicated for resource mobilisation with responsibility to Gramapanchayat.
10. Competitions to be held to pool innovative ideas/approaches for success of the programme with attractive prizes.

IEC PLAN OF ACTION AND ACTIVITY SEQUENCE OF ONE YEAR DURATION FOR SANITATION PROGRAMME

S.#	NAME AND BRIEF DESCRIPTION OF ACTIVITY	OBJECTIVE	TIME FRAME				METHODS / TOOLS	AGENCY RESPONSIBLE
			1Qtr	2Qtr	3Qtr	4Qtr		
A	PREPARATORY PHASE	To prepare the District and Panchayat bodies to take up the project	■				Participatory Formal / informal	All partner agencies
1	DISTRICT LEVEL MEETING (all partner agencies convened by District Collector / District Panchayat President)	Presentation of the proposed strategy of IEC for local sanitation Programme	■				Discussion	Dist President, Dist Collector, DRDA-PO, TC, Planning Officer, SEU, NGO
2	BLOCK LEVEL MEETING	Information sharing, work plan preparation for IEC	■				Discussion	BDO, Block President, all Panchayat members, Block members, SEU Representative
3	PANCHAYAT LEVEL MEETING	Formation of Ward Sanitation Committee	■				Discussion	Panchayat
4	NEIGHBOURHOOD COMMITTEES (NCs)	Identification of two volunteers from each NC (one woman, one man)	■				Opinion poll, social acceptance	Panchayat member (ward level)
5	WARD SANITATION COMMITTEE (WSC)	To prepare plan, Implement, Monitor all sanitation related activities	■				Discussions	Ward member (Convenor)
6	HEALTH PROMOTION TEAM (HPT) - Two representatives from each WSC	Dissemination of health messages, Management of Health materials, Organising cultural media, Planning and implementing health education activities with the help of WSC	■				PRA	Panchayat level core team - (1 Co-ordinator)
7	DISTRICT/BLOCK LEVEL TRAINING	To form a ToT Team	■				Participatory techniques	SEU, DRDA-TC

31



8	PANCHAYAT LEVEL TRAINING	Strengthen the capacity of WSC and HPT To develop Knowledge, Attitude and Skill in Planning, Implementing and Monitoring of sanitation facilities				Participatory techniques	ToT Team - Panchayat Level, Resource persons
9	SURVEY	Collect all data regarding sanitation and health aspects				Interview schedule, Village Walk, History line and Seasonal Calendar	Panchayat, WSC
10	CONSOLIDATION OF DATA (Panchayat level and copy to be sent to DSC)	To understand the gravity of the problem and to assess the impact of Total Sanitation after four years					Panchayat
B	MOBILISATION PHASE	Intense mobilisation and empowerment, communication and co-ordination to achieve Total Sanitation				Participatory techniques, Mass media, Inter-personal communication, Cultural media	Panchayat Sanitation Committee, WSC, HPT
1	REVIEW AND SUPPORT MEETING	To review the progress of Total Sanitation Programme to co-ordinate and pool all resources available for the mobilisation and implementation of the programme and support Block and Panchayat level ToT and also document the progress				Review meetings and Report collection and discussions Suggestion of follow-up activities	DSC
2	GENERAL HEALTH EDUCATION CAMPAIGN	Sensitising the general public on sanitation issues and also to inculcate a feeling of responsibility among them to achieve the ultimate objectives				Film shows, slide shows, printed materials, posters, bulletin boards, cultural media	Panchayats, WSC, HPT

32



3	BENEFICIARY SELECTION	To invite applications, short-list potential beneficiaries and finalise beneficiaries		■		Printed Application forms,	PSC
4	REVIEW AND SUPPORT MEETING	To review the progress of Total Sanitation Programme to co-ordinate and pool all resources available for the mobilisation and implementation of the programme and support WSC and HPT and also document the progress				Review meetings and Report collection and discussions Suggestion of follow-up activities	PSC
5	GROUP MEETINGS / NC MEETINGS	To provide an opportunity to the target group to clarify any doubts and to provide technical information and awareness on the use and maintenance of sanitary facilities and to define roles and responsibilities of user groups		■		PRA Techniques, Three-pile sorting cards, pocket-charts etc	HPT, WSC, Panchayat
6	POOLING OF FINANCIAL RESOURCES	Panchayat, Beneficiaries and support agencies to remit money into a local bank joint account		■			Panchayat
7	PIT-MARKING, DIGGING PITS (Householders), IDENTIFYING LOCATIONS FOR OTHER SANITATION FACILITIES	To begin implementation of the programme		■			WSC, PHC, VEO
8	PROCURING CONSTRUCTION MATERIALS	To ensure availability of quality construction materials for implementation of the programme (Low-cost options will be explored to minimise cost of project)			■		PSC
9	MODEL SANITATION FACILITIES AND MASON TRAINING	To demonstrate low-cost construction options and generate general awareness on the importance of the health aspects as well as the technical functionality of sanitation facilities	■			Training, demonstration and discussions	ToT, Block-level and panchayat level and Resource persons



10	CONSTRUCTION OF SANITATION FACILITIES						Dialogues with user groups regarding the use, maintenance and health aspects of sanitation facilities	Trained masons, WSC, NC and user groups
C	CONSOLIDATION AND FOLLOW-UP PHASE	Consolidate activities and plan for future programmes					Review and Evaluation	District, Block, Panchayat, Ward level
1	MONITORING OF SANITATION FACILITIES	To assess the impact of sanitation programme and to undertake appropriate interventions in areas of non-utilisation and failure in maintenance					Printed formats for monitoring	Twice a year Panchayat, HPT, WSC
2	POST CONSTRUCTION REORIENTATION	To equip the user-groups with sufficient skills in the O&M of sanitation facilities					Booklets on use and maintenance, cultural media, inter-personal communication	WSC, HPT, NC, Panchayat
3	REVIEW WORKSHOP	To share experiences from implementation of sanitation programme and to incorporate lessons learnt for future plans and programmes						DSC

34



PANCHAYATH WISE SANITATION DATA

Block	Panchayat	Ward	# of HH	# of BPL Families	# of BPL Families Without San units	# of APL families without San.units	Amount allotted for 1997-98	Amount for HE 1997-98	Remarks
ARYAD	Aryad	11	5259	3565	2167	505	600000	80000	
	Mararikulam (S)	15	9596	7300	2760	660	400000	50000	SEU - 500
	Mannanchery	14	8840	5600	3858	960			
TOTAL		40	23695	16465	8785	2125	1000000	130000	
AMBALAPUZHA	Punnapra	15	9036	3732	3472	1904			
	Ambalapuzha	15	8459	4980	4747	100			
	Purakkad	41	5287	2801	2507	950			
TOTAL		71	22782	11513	10726	2954			
THYAKKUTUSSERY	Thyakkutussery	10	3866	1704	1650	360			
	Perumbalam	8	1833	925	1050	350			
	Panavally	11	5078	3720	3300	426			
	Chennam Pallipuram	11	5105	3998	3000	35			
	Arookutty	9	2828	1849	1600	342			
	TOTAL		49	18710	12196	10600	1513		
CHAMBAKULAM	Thalavady	10	4540	3320	2598	108	99500		
	Edathua	10	4183	2673	1950	100			Backwater
	Thakazhy	10	3797	2300	1450	580	564000		
	Nedumudy	10	4243	2280	1840	200			
	Chambakulam	9	3299	1850	400	80			
	Kainakary	10	4050	3980	3500	50	900000	40000	
	TOTAL		59			11738	1118		
MAVELIKKARA	Thazhakara	13	9281	4800	3247	180	600000	100000	
	Mavelikkara Thekkekara	12	7097	1681	870	1985			
	Chettikulangara	13	8439	2891	1988	645	600000	25000	
	Chennithala-Trippeeruthara	11	7860	1515	1164	1330			
TOTAL					7269	4140			
PATTANAKKAD	Aroor	12	6238	3601	2900	230			Coastal
	Ezhupunna	10	6823	4679	4000	200	300000	15000	"
	Kodamthuruthy	9	3654	2486	1900	100	549500	249000	"
	Kuthiathodu	10	5319	1962	1772	100	325000	15000	"
	Pattanakkad	12	7000	4500	4000		460000	30000	"
	Thuravoor	11	5365	3714	2060	140	300000	45000	"
	Vayalar	10	6930	4230	3142		600000	10000	"
	Kadakkappally	9	3502	2049	1300	240			"
TOTAL		83	44831	27221	21074	1010	2534500	364000	

95

KANJIKUZH Y	Kanjikuzhy	11	5913	3124	1397	110			
	Mararikulam (N)	11	5845	2775	2271	340			
	Thannimukum	14	6917	3618	2976	348			
	Muhamma	10	6219	2622	2000	250			
	Cherthala	13	5854	4064	3000	250			
TOTAL					11644	1298			
HARIPPAD	Karuvatta	10	4398	3500	3120	40			
	Karthikappally	9	3648	2300	1950	150			
	Chingoli	8	3500	2890	2380	50			
	Veeyapuram	8			3250	100			
	Kumarapuram	10			3512	75			
	Cheruthana	8	2594	1200	950	175			
	Pallippadu	11	4897	1772	750	700			
	Harippad	9	3070	1350	972	650		19341	
	thrikkunnapuzha	11	4820	2783	2457	315			
TOTAL					19341	2225			
VELIYANAD	Muttar	8	2018	1769	1208	200	350000	50000	Backwater
	Veliyanad	8	2598	1865	1650	350	288780		
	Neelamperoor	8	2681	1515	1350	90			
	Kavalam	8	2834	2500	2200		400000	50000	
	Pulikkunnu	11	4529	3110	2800	110			
	Ramankary	8	2679	1936	1570	95			
TOTAL					10778	845			
BHARANIKAVU	Bharanicavu	13	7158	2395	1805	280			
	Chunakkara	10	4577	2033	1890	110			Midland, Hilly
	Nooranad	11	5348	2206	1900	350			
	Palamel	12	6497	2840	1989	512			Hilly
	Mavelikkara-Thamarakulam	11	5234	1954	1406	367			
	Vallikunnam	11	5885	3034	2105	413			
TOTAL					11095	2032			
CHENGANNUR	Mannar	8434	12	4300	3600	450	500000	40000	
	Pandanad	3410	8	814	720	30			
	Budhanur	4566	9	3450	3011	120	400000	25000	
	Thiruvandar	3916	9	1800	1200	150			
	Puliyoor	3214	9	2100	1750	200			
	Aia	2868	8	1036	720	112			
	Cheriyana	4442	10	1967	20	8			SEU -2354
	Mulakkuzha	6017	11	3200	2000	100			
	Venmany	4471	10	1800	1200	200			
TOTAL					14221	1370			

36

MUTHUKULAM	Arattupuzha	12	5546	4606	4500	700			Coastal
	Muthukulam	10	4302	3018	2174	150			
	Cheppadu	9	4995	3980	3400	95	100000		
	Kannalloor	10	4063	3800	3499	65			
	Pathiyoor	12	6282	5400	4550	120	816000		
	Krishnapuram	11	4771	3200	2240	150			
	Devikulangara	10	4164	2890	2000	320			
	Thrikkunnapuzha	11	6312	5792	2237	220			SEU -2044
TOTAL					24600	1820			

37

HOUSEHOLD LATRINE - PANCHAYATH

BLOCK	# LATRINE BPL APL		# LATRINE BPL APL	
	WATER LOGGED	ORDINARY	WATER LOGGED	ORDINARY
Chambakulam	10900	838	950	168
Mavelikkara	3000	4269	2250	1890
Aryad	5500	3285	1560	565
Ambalapuzha	8600	2126	1750	1204
Thykkattusery	4500	6100	350	1163
Pattanakadu	11500	9574	750	260
Kanjikuzhy	9600	2044	1000	298
Hanppad	13400	5941	1750	505
Veliyanad	10678	100	845	0
Bharanicavu	9500	1595	1650	382
Muthukulam	13805	10795	1205	556
Chengannoor	4300	9901	325	1045
TOTAL	105283	56568	14385	8036

MUNICIPALITY SANITATION DATA

MUNICIPALITIES WATER LOGGED ORDINARY TOTAL

Alappuzha	4500	2715	7215
Cherthala	1000	264	1264
Chengannoor	25	100	125
Kayamkulam	1250	1500	2750
Mavelikkara	50	262	312
TOTAL	6825	4841	11666



ENVIRONMENTAL SANITATION - PROPOSED UNITS FOR CONSTRUCTION/IMPROVEMENT

BLOCK	NO OF PANCHAYATH	NO OF COLONEY FOR IMPROVEMENT	NO OF MARKET TO BE IMPROVED	NO OF GARBAGE HEAPS NEED INTERVENTION	WELL MAIN-TENANCE	POND MAIN-TENANCE	STANDPOST DRAINAGE	CHAMP PIPE MAINTENANCE	DRAINAGE
Aryanad	3	45	1	3	700				
Thyakkattussery	5	51	7		190	400	188		18 Km
Pattanakkad	8	74	8	29	3065	876	228	41	58 Km
Kanjikuzhy	5	116	16	90	2330	893	140		310 Km
Ambalapuzha	3	54	4	10	750				38 Km
Chambakulam	6	75	4	45	72				50 Km
Veliyanad	6	75		100			75		50 Km
chengannoor	9	150	18	9	6000		500		20 Km
Harippad	9	120	15	50	5000		500		35 Km
Mavelikkara	4	135	6	75	63		250		118 Km
Muthukulam	7	30	40	15	3000		400		15 Km
Bharanikavu	6	30	4	10	1500				10 Km
TOTAL		955	123	436	22670	2169	2281	41	722 Km

39

HOUSEHOLD SANITATION - PANCHAYAT LEVEL
FUND FLOW : WATER LOGGED

YEAR	TOTAL UNITS PLANNED	CONTRIBUTION/ UNIT	TOTAL CRSP/DONOR CONTRIBUTION
1997	10000	1800	18000000
1998	35000	1800	63000000
1999	35500	2000	71000000
2000	24783	2000	49572000
TOTAL	105283		201572000

ORDINARY LATRINE

YEAR	TOTAL UNITS PLANNED	CONTRIBUTION/ UNIT	TOTAL CRSP/DONOR CONTRIBUTION
1997	5000	1500	7500000
1998	20000	1500	30000000
1999	20000	1800	36000000
2000	11568	1800	20822400
TOTAL	56568		94322400

MUNICIPALITIES

YEAR	TOTAL UNITS WATER LOGGED	CONTRIBUTION/ UNIT	TOTAL CRSP/DONOR CONTRIBUTION
1998	4000	1800	7200000
1999	2000	2000	4000000
2000	825	2000	1650000
TOTAL	6825		12850000

YEAR	TOTAL UNITS ORDINARY	CONTRIBUTION/ UNIT	TOTAL CRSP/DONOR CONTRIBUTION
1998	2000	1500	3000000
1999	2841	1800	5113800
TOTAL	4841		8113800

H°

ABOVE POVERTY LINE CONTRIBUTION PATTERN

YEAR	TOTAL UNIT WATER LOGGED	UNIT COST	CRSP/BANK DONOR LOAN
1998	5000	1800	9000000
1999	5000	2000	10000000
2000	4385	2000	9370000
TOTAL	14385		28370000

YEAR	TOTAL UNIT ORDINARY	UNIT COST	CRSP/BANK DONOR LOAN
1998	3000	1500	4500000
1999	4000	1800	7200000
2000	1036	1800	1864800
TOTAL	8036		13564800

BUDGET FOR HOUSEHOLD SANITATION

PANCHAYATS		UNITS	BUDGET
BPL	WATER LOGGED	105283	201572000
	ORDINARY	56568	94322400
APL	WATER LOGGED	14385	28370000
	ORDINARY	8036	13564800
TOTAL			
MUNICIPALITY	WATER LOGGED	6825	12850000
	ORDINARY	4841	8113800
TOTAL		195938	358793000

41

BUDGET ALLOCATION FOR ENVIRONMENTAL SANITATION

	1997-98 15%	1998-99 35%	99-2000 35%	2000-01 15%	Total
1. Colony improvement	2865000	6685000	6685000	2865000	19100000
2 Market improvement	461250	1076250	1076250	461250	3075000
3 Solid waste management	1308000	3052000	3052000	1308000	8720000
4. Well improvement	1308000	7934500	7934500	3400500	22670000
5 Pond maintenance	3400500	1518300	1518300	650700	4338000
6. Standpost drainaghe	650700	1197525	1197525	513225	3421500
7 Champ pipe maintenance	513225	215250	215250	92250	615000
8 Drainage construction	92250	63175000	63175000	27075000	180500000
MUNICIPALITIES	750000	1750000	1750000	750000	5000000
TOTAL	1 1E+07	86603825	86603825	37115925	247439500

A2

INSTITUTIONAL LATRINE

SCHOOL, PHC, ANGANWADI AND OTHER INSTITUTIONS (PANCHAYATH & *M. ni paly*)

YEAR	COST/UNIT	NO.OF UNITS PLANNED	PTA/PANCT. CONTRIBUTION	CRSP CON- TRIBUTION	TOTAL
1997-98	10000	100	500000	500000	1000000
1998-99	11000	300	1650000	1650000	3300000
99-2000	12000	400	2400000	2400000	4800000
2000-01	13000	200	1300000	1300000	2600000
TOTAL		1000	5850000	5850000	1 2E+07

H3

PAY & USE COMFORT STATION

YEAR	COST/UNIT	NO OF UNITS PLANNED	LOCAL CON- TRIBUTION	CRSP/DONOR CONTRIBUTION	TOTAL
1998-99	300000	3	450000	450000	900000
99-2000	400000	5	1000000	1000000	2000000
2000-01	460000	4	920000	920000	1840000
T O T A L		12	2370000	2370000	4740000

PRODUCTION CENTRE

	COST/UNIT	NO OF UNITS PLANNED			TOTAL FROM SEUF & UNICEF
	300000	12			3600000

44

SUMMARY BUDGET - IEC ACTIVITIES (1996-2000)
TO BE CARRIED OUT BY SEU FOUNDATION

I. Material production and distribution

1.1	Exhibiting banners, posters, slides etc	75 banners 3650 posters (71 Panchayats 5 municipalities)	36,00,000
1.2	Exhibiting, hoardings in central places in panchayat/municipalities	75 nos.	3,75,000
1.3	Preparation of Exhibition material District - 1 set		3,50,000
1.4	Production, printing, distribution of IEC material - Leaflet, pamphlets booklets on instruction of use & maintenance, instruction sheets etc. Application form booklets	1,80,000 copies each item	25,00,000
			----- 68,25,000 =====

45

2. TRAINING AND CAPACITY DEVELOPMENT

	<u>Description</u>	<u>Quantity</u>	<u>Cost</u> <u>(in Rs.)</u>
2.1	Training to panchayath/ block level Health promotion team 12 block level training 30 participants in each section - 3day training	15 training	4,00,000
	Selected panchayath members training 3 sessions 40 participants each 3 day training	3 training	
	Training to H.P.I. panchayath level 35 batches (1500 participants)3 day residential training (15000x35)	35 batches	5,25,000
2.2	Training to panchayat sanitation committee members, Two day training, two batches per panchayat (Rs.5000x150 batches)	150 trainings	7,50,000
2.3	Training to ICDS workers, 40 sessions one day training for 1200 members (Rs.3000x40)	40 training	1,20,000

17,95,000
=====

46

3. Community level Activities

	<u>Description</u>	<u>Quantity</u>	<u>Cost (Rs.)</u>
3.1	Organisation of HPT in panchayath/municipalities 75 x Rs.10,000	75 team	7,50,000
3.2	Conducting mass education per panchayth Rs.2000 each 75 x Rs.5,000		3,75,000
3.3	Conducting intensive education 75 x Rs.2,000		1,50,000
3.4	Film shows, video shows, street drama, Kalajatha cultural programme, exhibition, competitions etc 75 x Rs.10,000		7,50,000
3.5	Beneficiary education class/ meetings- 3 class for each beneficiary per beneficiary Rs.10 each x 1,50,000		15,00,000

			35,25,000
			=====

H7

4. Assessment and monitoring activities

<u>Description</u>	<u>Amount</u>
4.1 Printing of survey form	
4.2 Printing of monitoring form (quarterly (twice in yearly))	
4.3 Monitoring activities & preparation of reports (stationery accessories)	14,00,000
4.4 Evaluation of school health clubs	
4.5 Evaluation of other environmental facilities	

5. School Health Education

5.1 Formation and training of teachers (yearly 1 training 2 days residential) 400 teachers Rs.20,000 x 8x3	4,80,000
5.2 Competitions-exhibitions on health and sanitation District (1) Block (12+5) panchayat(71) for 3 years	9,00,000
5.3 Booklets on health & sanitation for distributing among high schools & UP sessions	4,50,000

	32,30,000
	=====

6. Seminars & Workshops and Camps

6.1 District level workshops 50 persons for 2 days	50,000
Block level seminars for teachers and functionaries	1,20,000
6.2 Mason training (20x75x1500)	22,50,000
Lady mason 1 team / block 12 x 20 x 2500	6,00,000

	30,20,000
	=====

148

7. Miscellaneous and unforeseen expenses 2,50,000

Prizes

Best district	-	State
Best panchayath	-	Block
Best Block	-	District
Best Health Promotion team		Block
Best Sanitation Mart		UNICEF / SEU

59

PROJECT ESTIMATE

I HOUSEHOLD LATRINE

PANCHAYAT LEVEL

Below Poverty line	Water-logged	201572000
	Ordinary	94322400

MUNICIPALITY LEVEL

Water-logged	12850000
Ordinary	8113800

II INSTITUTIONAL LATRINE 5850000

III PAY AND USE LATRINE 2370000

IV ENVIRONMENTAL SANITATION 247439500

V IEC

1 Maternal production and distribution	6825000
2 Training and Capacity Development	1795000
3 Community level activities	3525000
4 Assessment and Monitoring activities	3230000
5 Seminar/ Workshops and Camps	3020000
6 Miscellaneous and unforeseen expenses	250000

Total 591162700

Administrative Overheads @3% of above Total 17734881

TOTAL 608897581

ABOVE POVERTY LINE HOUSEHOLD SANITATION

Water-logged	28370000
Ordinary	13564800

TOTAL 41934800

Loan facility to be arranged by District Sanitation Committee through CR

5

PROJECT ESTIMATE

I HOUSEHOLD LATRINE

PANCHAYAT LEVEL

Below Poverty line	Water-logged	201572000
	Ordinary	94322400

MUNICIPALITY LEVEL

Water-logged	12850000
Ordinary	8113800

II INSTITUTIONAL LATRINE 5850000

III PAY AND USE LATRINE 2370000

IV ENVIRONMENTAL SANITATION 247439500

V IEC

1 Maternal production and distribution	6825000
2 Training and Capacity Development	1795000
3 Community level activities	3525000
4 Assessment and Monitoring activities	3230000
5 Seminar/ Workshops and Camps	3020000
6 Miscellaneous and unforeseen expenses	250000

Total 591162700

Administrative Overheads @3% of above Total 17734881

TOTAL 608897581

1997-98	1998-99	1999-2000	2000-2001	2001-2002	TOTAL
20%	30%	20%	20%	10%	
40314400	60471600	40314400	40314400	20157200	201572000
18864480	28296720	18864480	18864480	9432240	94322400
2570000	3855000	2570000	2570000	1285000	12850000
1622760	2434140	1622760	1622760	811380	8113800
1170000	1755000	1170000	1170000	585000	5850000
474000	711000	474000	474000	237000	2370000
49487900	74231850	49487900	49487900	24743950	247439500
1365000	2047500	1365000	1365000	682500	6825000
359000	538500	359000	359000	179500	1795000
705000	1057500	705000	705000	352500	3525000
646000	969000	646000	646000	323000	3230000
604000	906000	604000	604000	302000	3020000
50000	75000	50000	50000	25000	250000
118232540	177348810	118232540	118232540	59116270	591162700
3546976	5320464	3546976	3546976	1773488	17734881
121779516	182669274.3	121779516	121779516	60889758	608897581

ABOVE POVERTY LINE HOUSEHOLD SANITATION

Water-logged 28370000

Ordinary 13564800

TOTAL 41934800

Loan facility to be arranged by District Sanitation Committee through CRSP/Bank/Donor

51

3