

# THE BLAIR LATRINE

## A BUILDERS MANUAL FOR THE 4 BAG MODEL AND HAND WASHING TANK

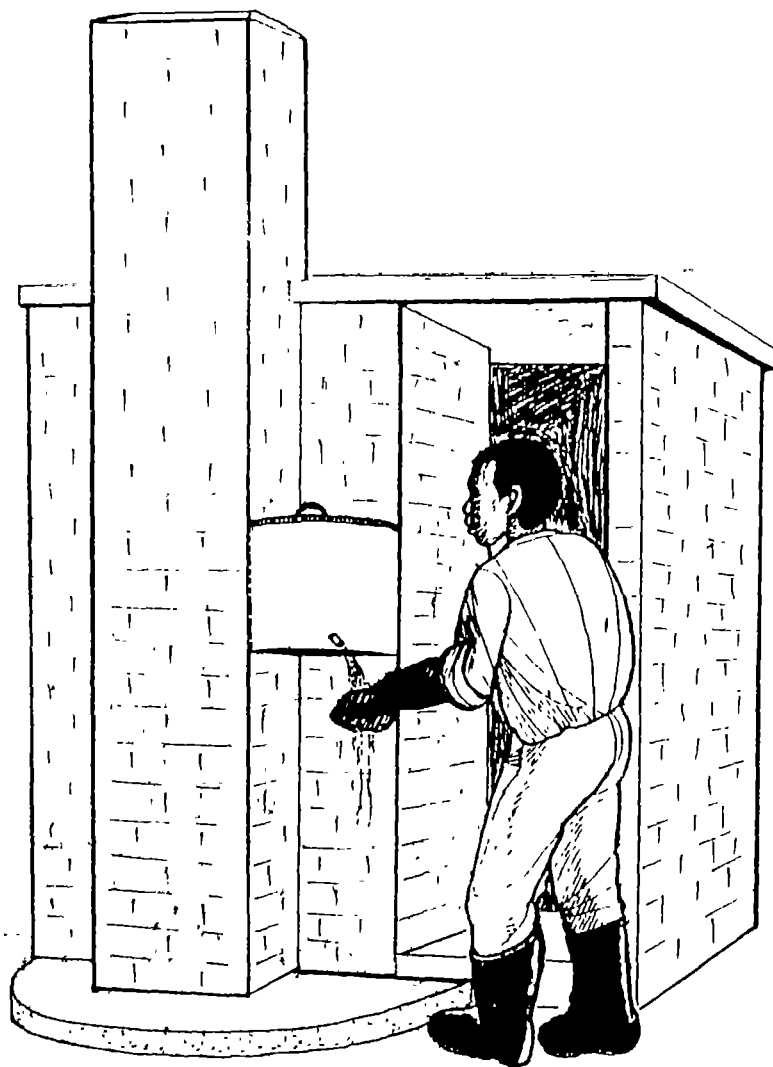

*Library*  
IRC International Water  
and Sanitation Centre  
Tel.: +31 70 30 889 80  
Fax: +31 70 35 889 64

MVURAMANZI TRUST

321.4-95BL-14353

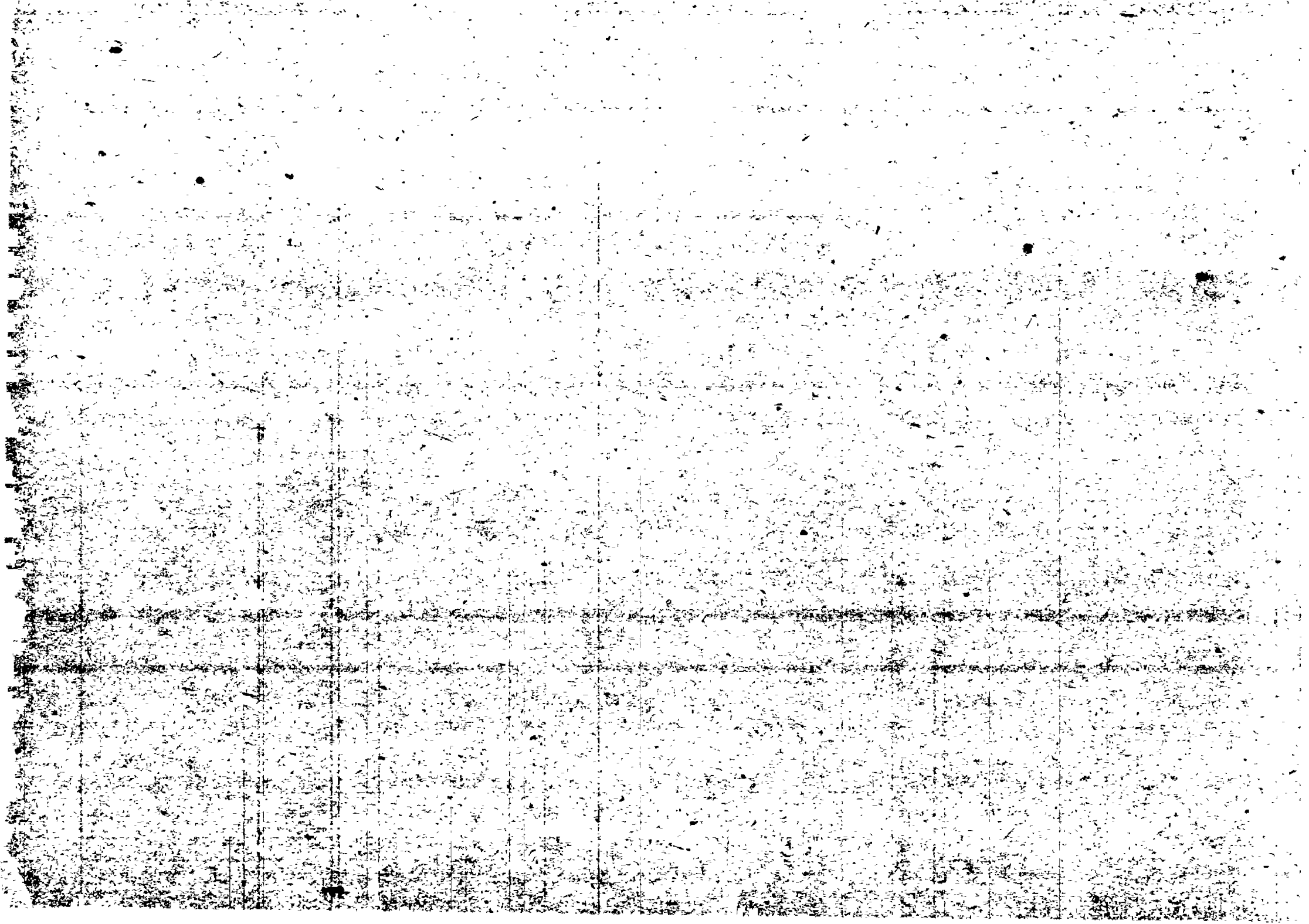

## INTRODUCTION

The standard Blair Latrine consumes about 5 bags of cement and provides a sturdy structure that will in most cases outlast the pit, which for most family latrines lies between 12 - 15 years. A slightly lower cost Blair Latrine has been designed and tested for several years and uses four bags of cement. This model is now being used in several areas of Zimbabwe in the Ministry of Health's National Rural Sanitation Programme.

The "4 bag" model uses fired bricks throughout and has a fully brick lined pit, a concrete slab, a brick vent pipe and brick superstructure. The roof is ideally made of ferrocement, and consumes one bag of cement. However the roof can also be made of asbestos or tin when 3 bags of cement are required for the entire structure. Most of the saving in cement is achieved by using traditional anthill mortars in the superstructure, and by a slight reduction in pit and slab size compared to the standard Blair Latrine. The brick vent pipe is made with 4 bricks per course compared to 6 bricks on the standard model. Where 4 bricks are used per course great care is required to ensure that the internal surface of the brick pipe is smooth and not obstructed by cement mortar. The screen for the smaller pipe measures 225mm X 225mm which also saves on screen material - the standard screen measures 300mm X 300mm. The superstructure foundation and the first course of brickwork for the superstructure are made with cement mortared brickwork. From then on, traditional mortar using anthill soil, often combined with sand, is used to bond the fired brick walls of the structure. The internal walls of the structure are plastered with cement mortar and a hard surface latrine floor is also built.

From the users point of view any technique which saves on cost is welcome, provided that the durability of the unit is not seriously affected. Models which use less cement and more traditional material are cheaper to construct and this may have important implications in the future. However it is not wise practice to build a cheap latrine which lasts only a few years. It is far wiser to build a durable latrine which will last for the length of life of the pit. The high level of subsidy currently provided by donor organisations through the Ministry of Health cannot be sustained for ever, and now is the time to introduce options which retain all the properties of a standard Blair Latrine, but provide it at lower cost.

Material subsidies for the Blair Latrine vary somewhat from one programme to another within the Ministry of Health and Child Welfare Programme. Currently the lowest subsidy, offered by the Mvuramanzi Trust, is just 3 bags of cement with no wire reinforcing. The owner is expected to provide reinforcing wire and also an extra bag of cement before a subsidy is provided. 4 bags of cement and reinforcing wire are provided as part of the Sida assisted programmes in Mashonaland East and Manicaland. Elsewhere 5 bags of cement are provided together with reinforcing wire. Screens are provided through the Ministry of Health or NGO's. Clearly the lower the subsidy the greater the coverage, and this should be the overall aim of the programme - to slowly make the family owner more and more responsible for paying for and completing the Blair Latrine himself. Because the subsidy acts as such a great incentive to the family, reducing the subsidy should take place slowly and in carefully judged stages.

This manual also includes a description of building a handwashing tank which is fitted to the latrine. Very often the tank is built at the same time as a new latrine, but it is also possible to add the tank to an older latrine. Handwashing forms a vital part of the hygienic process attached to latrine use.

I wish to acknowledge the full support of the Ministry of Health and Child Welfare, and the Department of Environmental Health in particular. The drawings used in this manual are taken from earlier manuals produced for the Ministry of Health with illustrations prepared by Kors de Waard. Much credit is also due to the field teams who have played an important part in the rural sanitation programme. In particular the efforts of Ephraim Chimbunde, Nason Mtakwa, Fambi Gono, Philimon Kademeteme, Joshua Mazanza and their supporting staff are to be commended.

I also wish to thank Sida who have encouraged the wider use of lower cost options in water and sanitation projects in Zimbabwe and have assisted in supporting the research and development of such technologies. Thanks are also due to Norad, WaterAid UK, Rotary, UNICEF and the Oak Foundation who have supported the current programme of promoting lower cost Blair Latrines.

Peter Morgan

Mvuramanzi Trust  
Harare

September 1995

LIBRARY IRC  
PO Box 93190, 2509 AD THE HAGUE  
Tel.: +31 70 30 689 80  
Fax: +31 70 35 899 64  
BARCODE:  
LO: 14353  
321.4 95BL

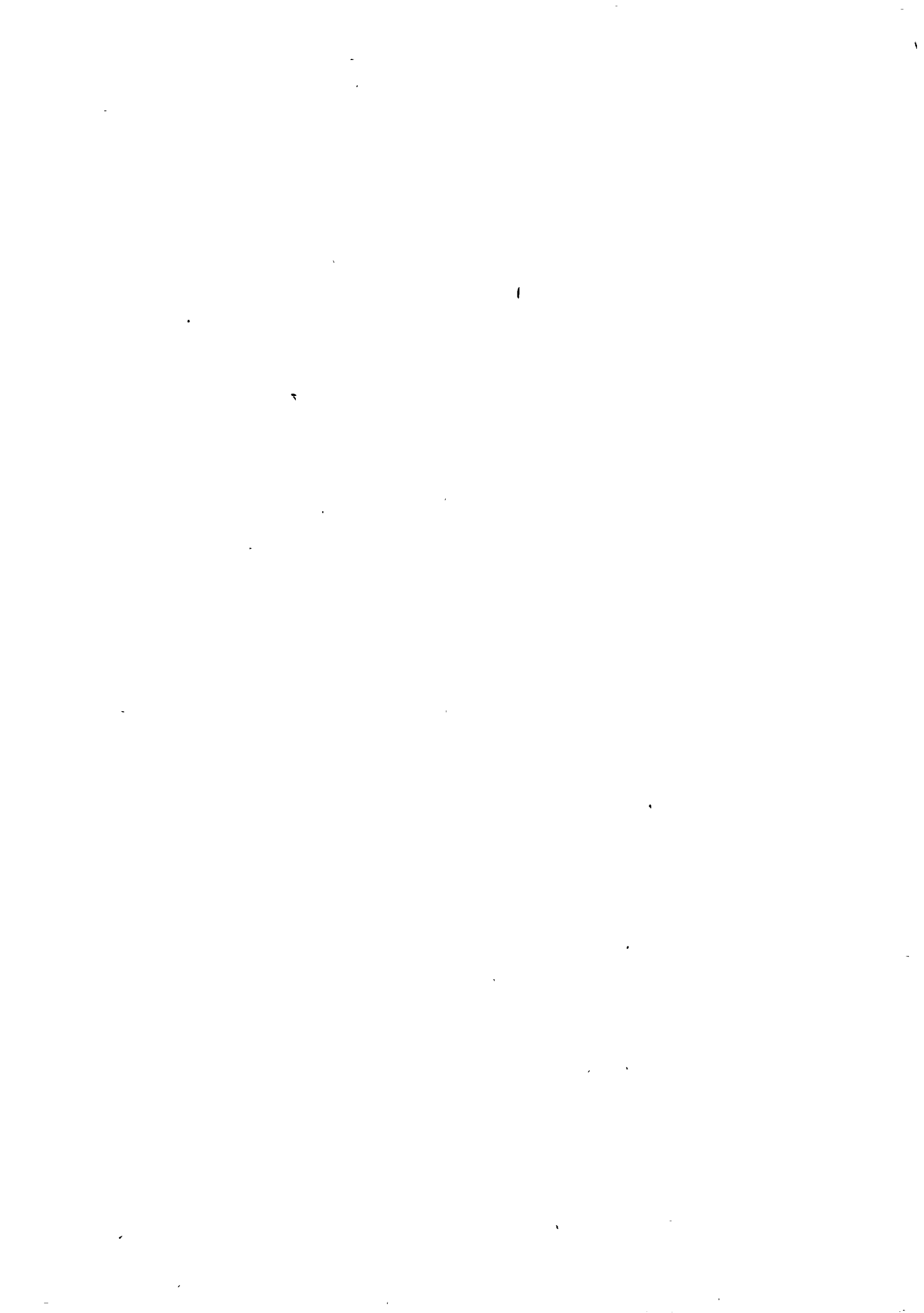

# HOW THE BLAIR LATRINE WORKS

The latrine slab is made with two holes, one for the squatting hole and one for the vent pipe. The vent pipe sucks air from the pit and fresh air is drawn down through the squat hole. The latrine itself is therefore odourless.

Flies approaching the latrine are attracted to odours coming from the pipe but cannot pass the screen to enter the pit. Flies escaping from the latrine are attracted to the light coming down the pipe but are trapped by the screen and cannot escape.

## THIS IS A CUT OPEN VIEW OF A BLAIR LATRINE

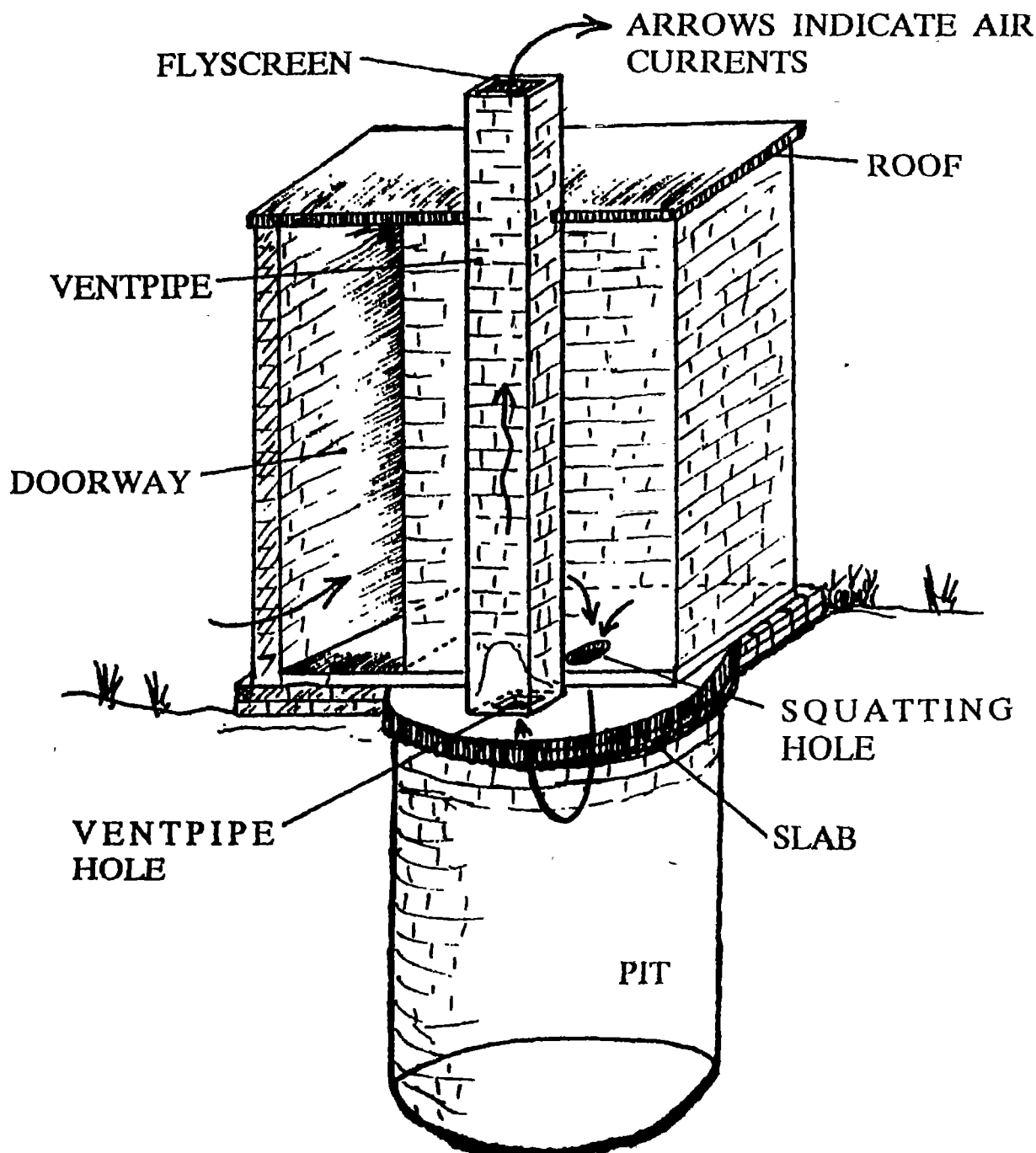

# MATERIALS REQUIRED TO BUILD A "4 BAG" BLAIR LATRINE

**Cement** - 4 bags

**River sand** - approx 1/4 cu.m.

**Pit sand** - approx 3/4 cu.m.

**Reinforcing wire** (20m X 3mm)

**Flyscreen** (225mm X 225mm)

(Aluminium or stainless steel)

4 BAGS CEMENT

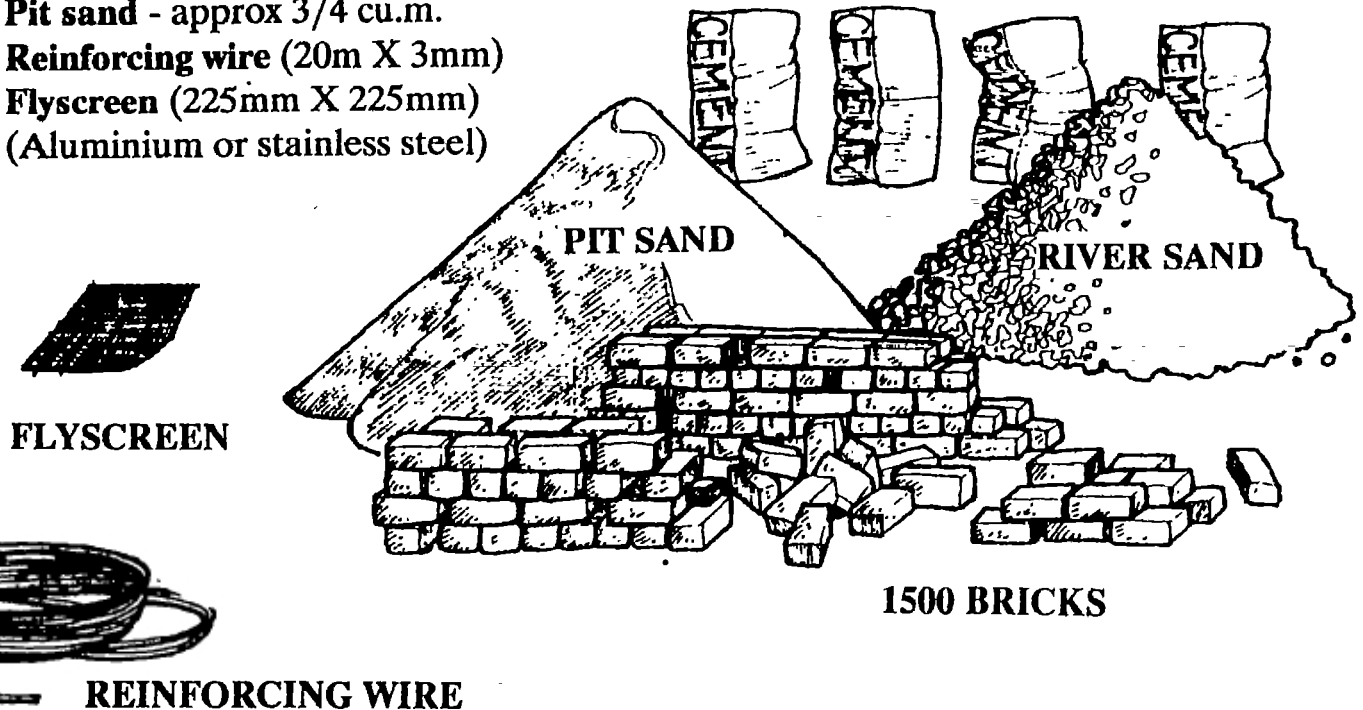

## SITING THE BLAIR LATRINE

The site should be chosen by the family with assistance from an Environmental Health Technician and should be at least 30 metres from a well.

The site should be:

**Down hill from a well or borehole** - so that waste from the latrine does not drain into the water supply.

**Where the soil is firm** - so that the latrine will not collapse

**On slightly raised ground** - so that rainwater can drain away

**Near the house** - so that the latrine can be used easily

**Away from trees** - so that air can flow easily over the pipe

**Facing the wind** - so that air blows into the entrance

# MEASUREMENT OF CEMENT

WHERE A LIMITED NUMBER OF BAGS OF CEMENT ARE BEING USED FOR THE CONSTRUCTION OF A BLAIR LATRINE IT IS IMPORTANT TO MEASURE THE CEMENT ACCURATELY SO THAT MAXIMUM BENEFIT CAN BE MADE OF THE CEMENT.

ONE BAG OF CEMENT CAN BE DIVIDED INTO 8 X 4.5 LITRE TINS OF CEMENT, WITH A LITTLE LEFT OVER. A 5 LITRE TIN MAKES A CONVENIENT MEASURE. 4.5 LITRES MEASURES JUST SHORT OF THE FULL TIN.

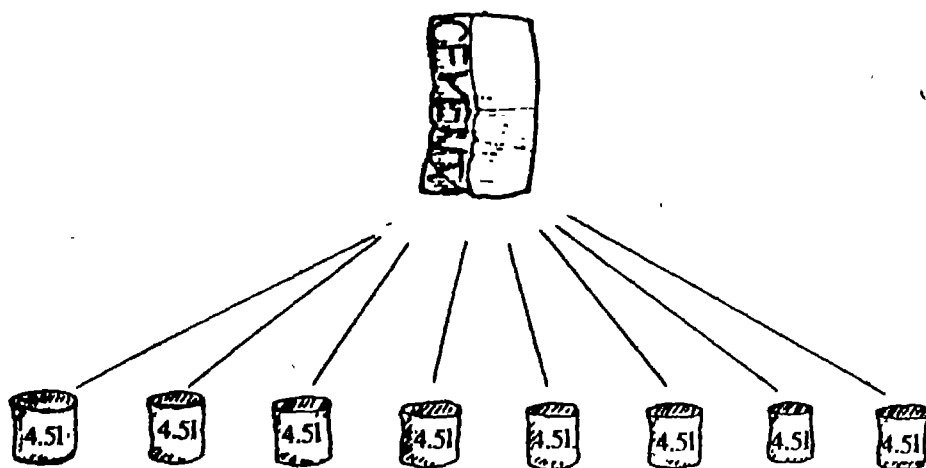

THE FOLLOWING AMOUNTS OF CEMENT SHOULD BE USED TO MAKE DIFFERENT PARTS OF THE "FOUR BAG" MODEL OF THE BLAIR LATRINE.

PART OF LATRINE	CEMENT USED (4.5 LITRE TINS)	SAND USED (4.5 LITRE TINS)	MIX
PIT LINING	8	80 Pit sand	10:1
SLAB	4	20 River sand	5:1
BRICK VENT PIPE	2.5	20 Pit sand	8:1
FOUNDATIONS	2	16 Pit sand	8:1
INTERNAL PLASTER	4	32 Pit sand	8:1
FLOOR	3.5	14 River sand	4:1
FERROCEMENT ROOF	8	24 River sand	3:1

# THE CONSTRUCTION

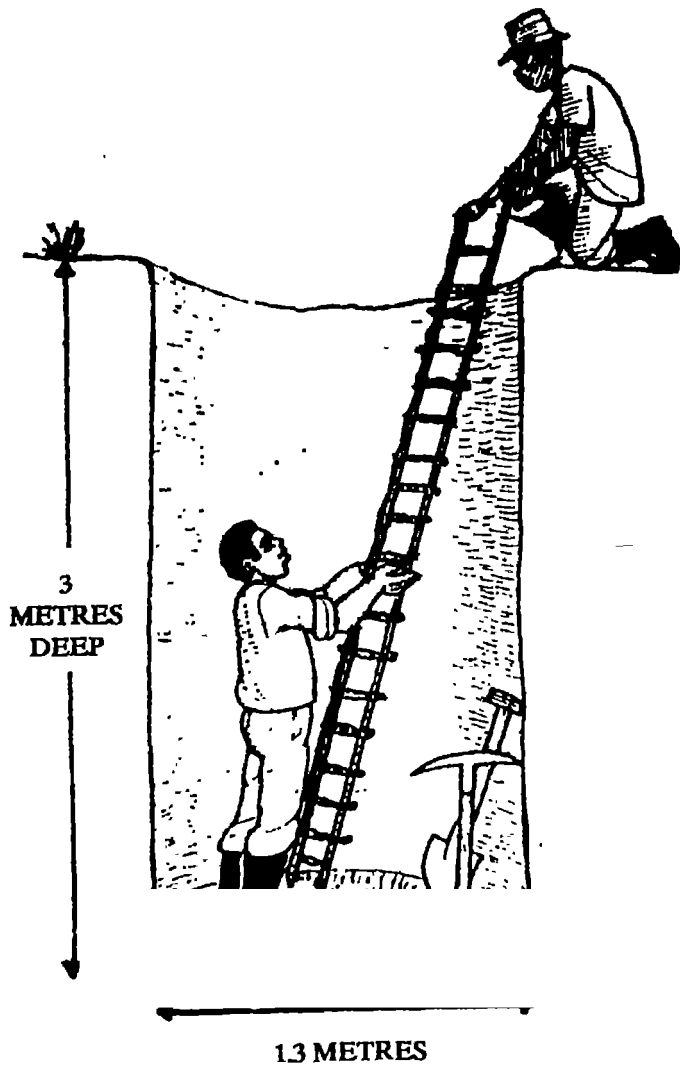

## STAGE 1. DIG THE PIT

DIG A ROUND PIT  
1.3 METRES IN  
DIAMETER AND  
3 METRES DEEP

DIG THE PIT  
WITH STRAIGHT  
SIDES

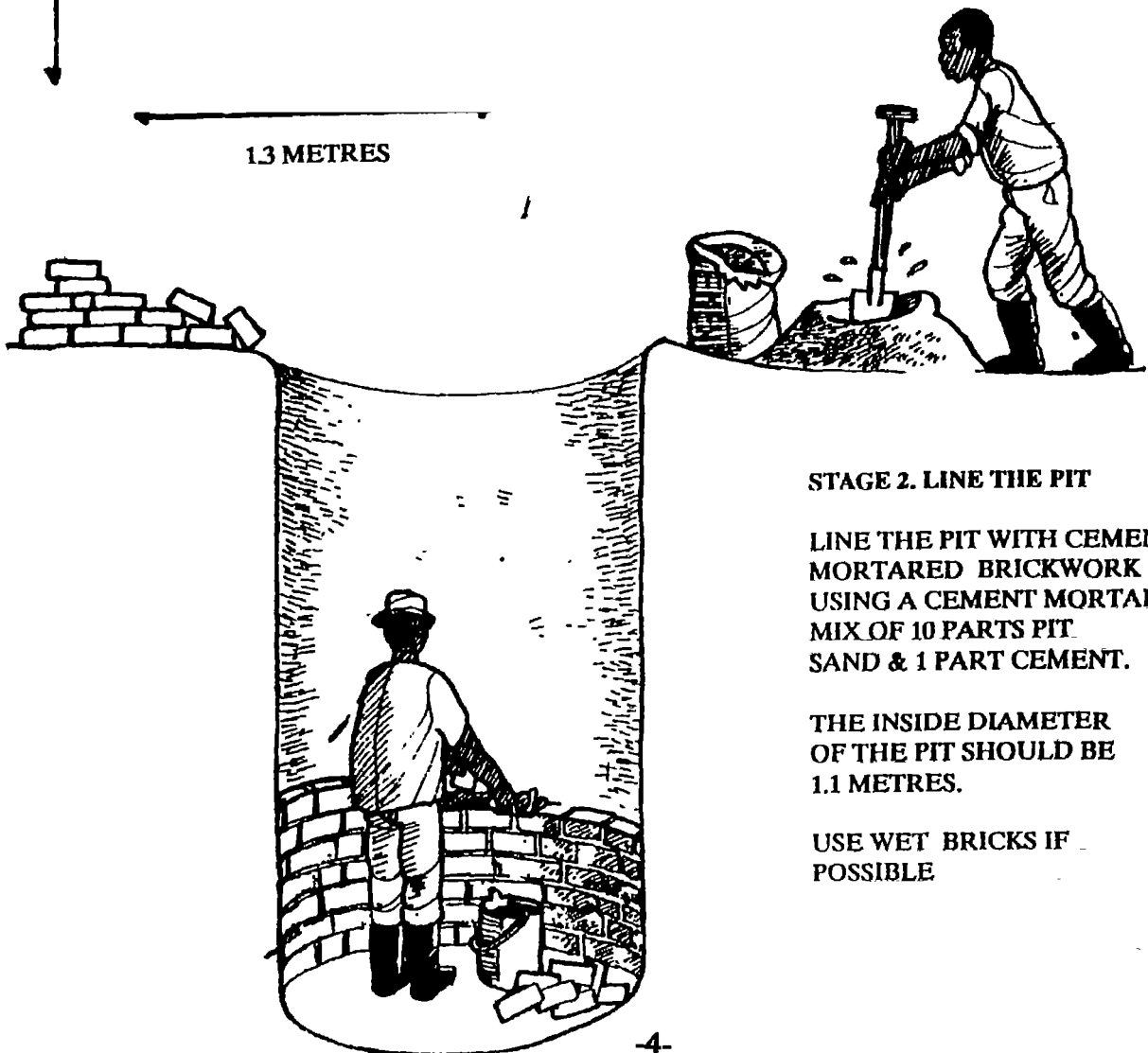

## STAGE 2. LINE THE PIT

LINE THE PIT WITH CEMENT  
MORTARED BRICKWORK  
USING A CEMENT MORTAR  
MIX OF 10 PARTS PIT  
SAND & 1 PART CEMENT.

THE INSIDE DIAMETER  
OF THE PIT SHOULD BE  
1.1 METRES.

USE WET BRICKS IF  
POSSIBLE



**STAGE 3. FINISH THE LINING**

CONTINUE THE PIT LINING TO ONE COURSE ABOVE GROUND LEVEL.

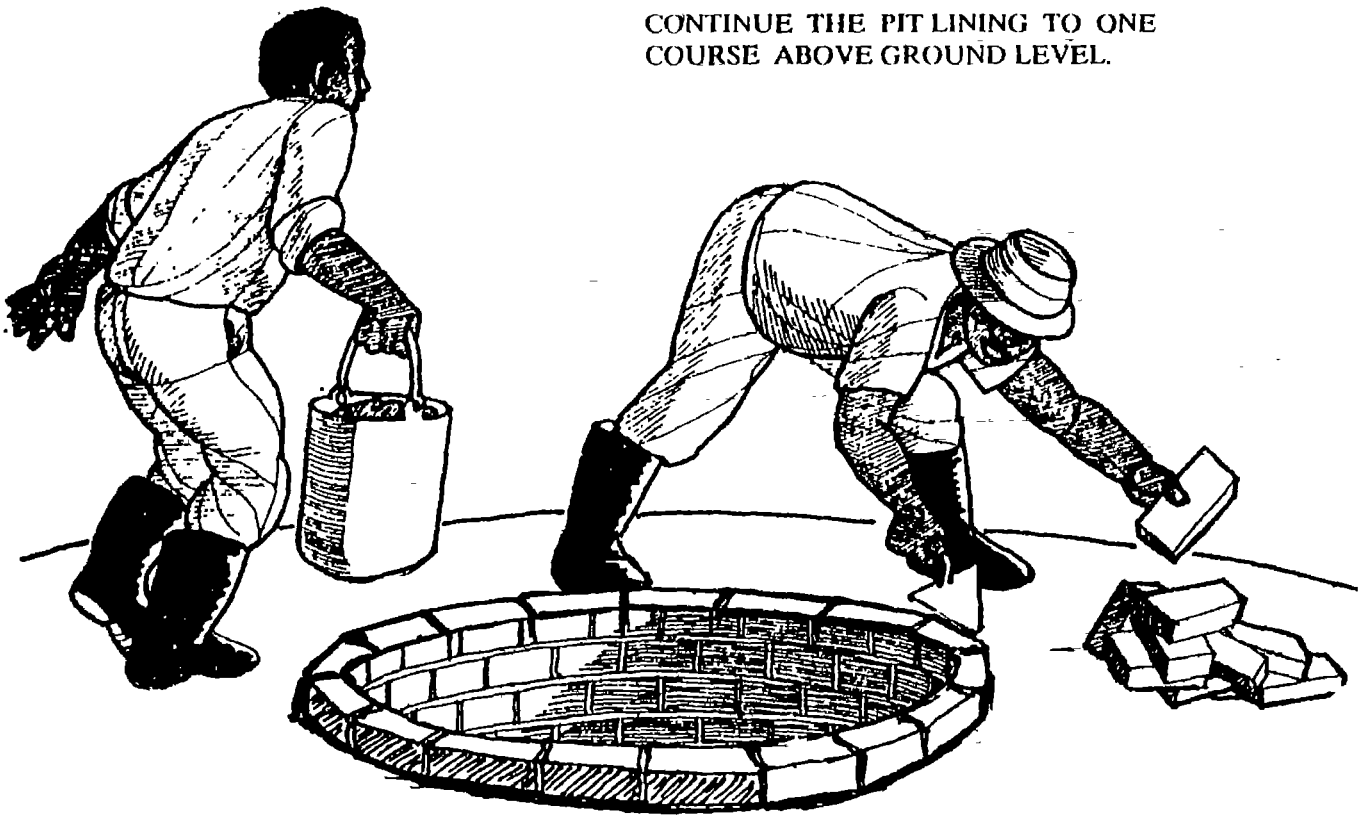

**STAGE 4. MAKE THE COVERSLAB MOULD**

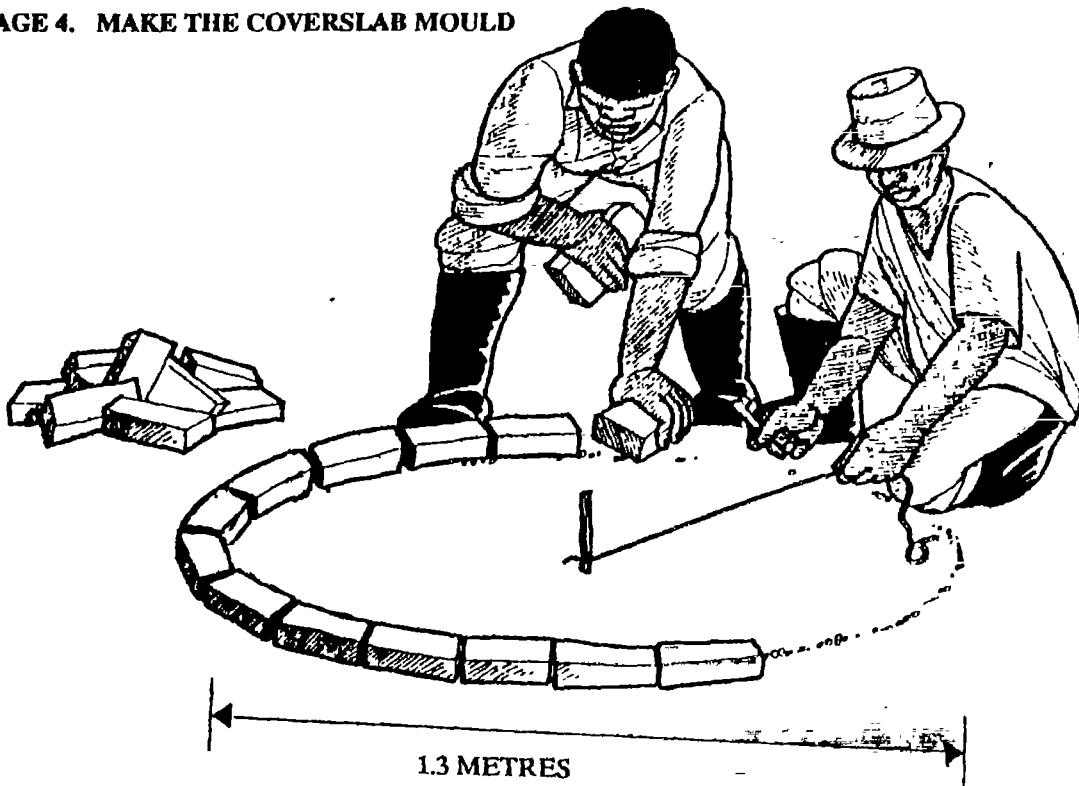

MAKE A CIRCLE OF BRICKS WITH INTERNAL DIAMETER OF 13 METRES  
LAY CEMENT BAG PAPER OR PLASTIC UNDER THE MOULD SITE

**STAGE 5. MAKE THE COVERSLAB**

ARRANGE BRICKS TO FORM VENT PIPE HOLE AND SQUAT HOLE AS SHOWN  
VENT PIPE HOLE IS 140mm X 140mm SQUAT HOLE IS 280mm X 140mm.  
CONCRETE MIXTURE IS 5 PARTS WASHED RIVER SAND 1 PART CEMENT  
ADD HALF THE MIXTURE FIRST ( FULL MIXTURE USES HALF BAG CEMENT)  
ADD 3mm REINFORCING WIRE WITH 150mm SPACES  
ADD REMAINING MIXTURE UNTIL SLAB IS 75mm THICK  
LEAVE FOR AT LEAST 5 DAYS TO CURE- KEEP WET.



15cm 14cm 40cm 30cm 31cm

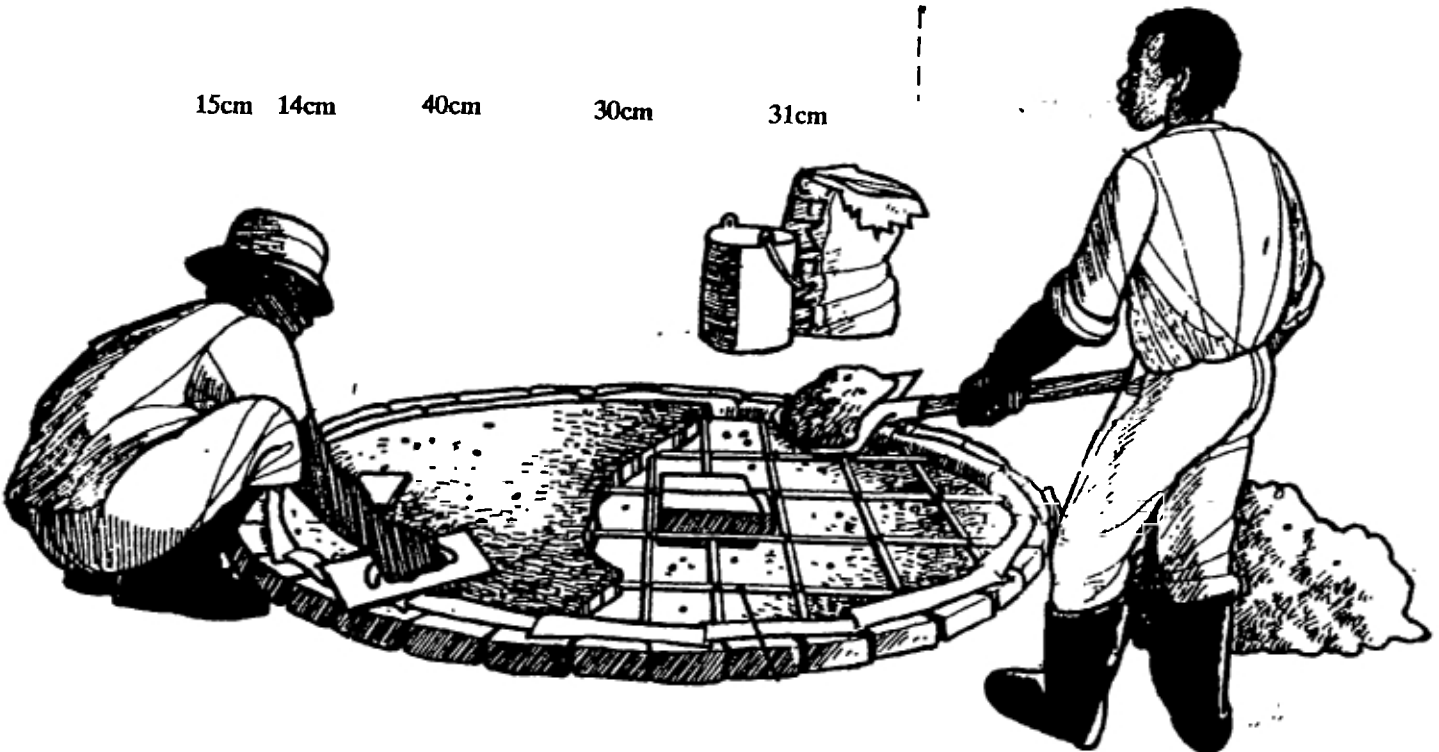

**STAGE 6. PLACE COVERSLAB ON PIT**

BED DOWN THE COVER SLAB ON CEMENT MORTAR LAID OVER THE BRICKS ENSURE THE ORIENTATION OF THE COVERSLAB IS CORRECT. THIS IS NORMALLY TOWARDS THE HOMESTEAD AND TOWARDS THE WIND. THE VENT PIPE WILL BE BUILT ON THE SAME SIDE AS THE DOORWAY.



MAKE SURE THE VENT PIPE HOLE IS OVER THE PIT.

A GOOD SEAL BETWEEN THE COVER SLAB AND THE COLLAR PREVENTS FLIES FROM ENTERING AND LEAVING THE PIT OTHER THAN THROUGH THE SQUAT AND VENT PIPE HOLES.

**STAGE 7. MAKE THE SUPERSTRUCTURE FOUNDATION**

THE FOUNDATION IS LAID OUT AS SHOWN IN THE PLAN PROVIDED LATER IN THIS MANUAL. THE FOUNDATION IS MADE UP OF BRICKS CEMENT MORTARED TOGETHER IN A COURSE 225mm WIDE. THE SURFACE SOIL IS DUG OUT FIRST AND THE FOUNDATION LAID ON FIRM GROUND. THE FOUNDATION IS BUILT UP TO SLAB LEVEL.

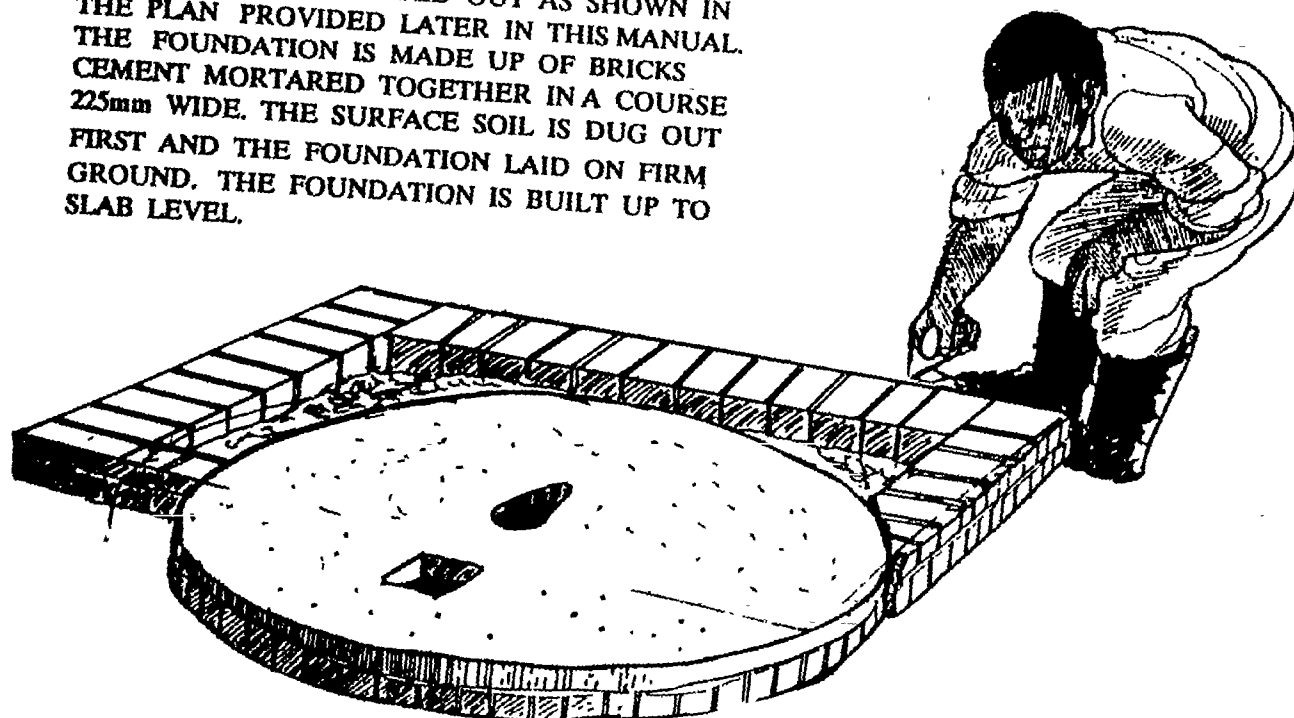

**STAGE 8. MAKE THE FIRST COURSE OF BRICKS FOR THE VENT PIPE & SUPERSTRUCTURE**

THE FIRST COURSE OF BRICKS IS BUILT UP ON THE FOUNDATION WITH CEMENT MORTAR (8 PARTS PIT SAND & 1 PART CEMENT). THE MEASUREMENTS SHOULD BE TAKEN FROM THE PLAN IN THIS MANUAL. THE VENTILATION PIPE IS MADE WITH FOUR BRICKS PER COURSE ARRANGED AS SHOWN IN THE DIAGRAM. IT IS VERY IMPORTANT THAT THE INTERNAL MEASUREMENT OF 140mm X 140mm IS MAINTAINED THROUGHOUT THE LENGTH OF THE PIPE.

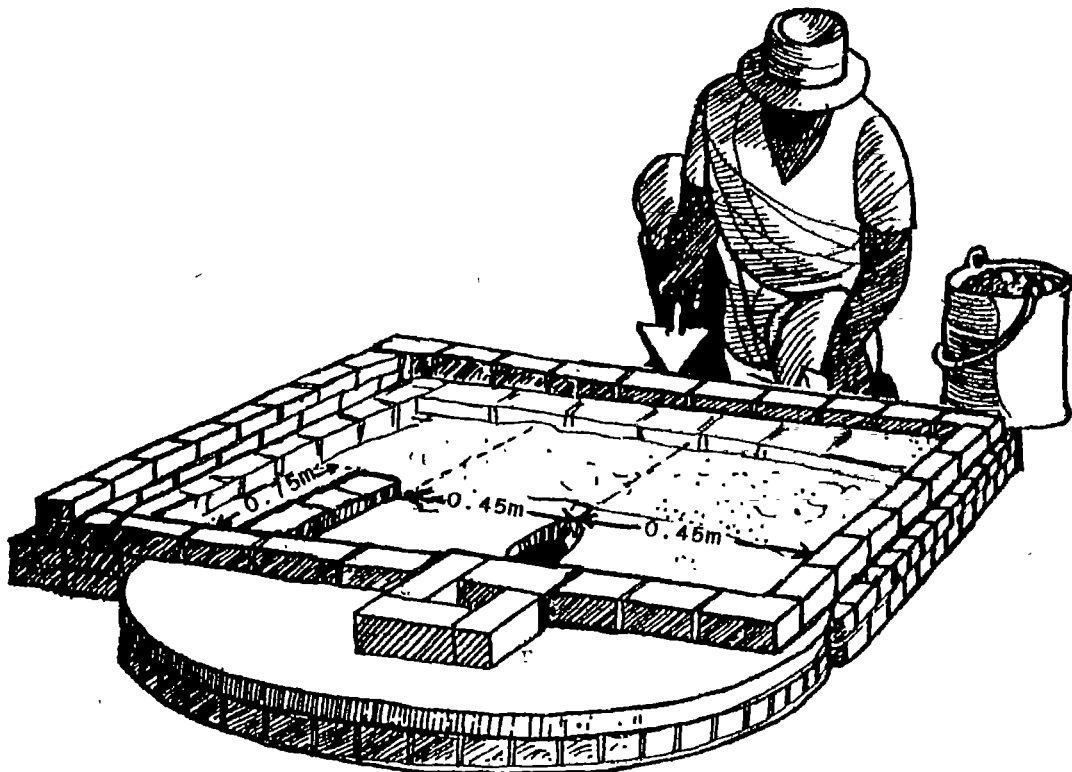

THE BRICK VENT PIPE BUILT ON LOWER COST MODELS OF THE BLAIR LATRINE IS MADE WITH 4 BRICKS PER COURSE. IT IS VERY IMPORTANT TO ENSURE THAT THE INTERNAL MEASUREMENT IS MAINTAINED AT 140MM X 140MM AND THE INTERNAL SURFACE IS SMOOTH.

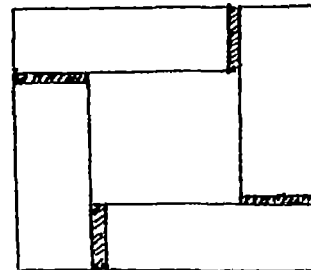

**STAGE 9. MAKE THE BRICK VENTILATION PIPE**

THE BRICK VENTILATION PIPE IS NOW BUILT UP TO 28 COURSES AS SHOWN IN THE DIAGRAM. CEMENT MORTAR IS USED TO BOND THE BRICKS. THE INTERNAL MEASUREMENT OF 140mm X 140mm MUST BE MAINTAINED AT EVERY COURSE AND THE INTERNAL WALLS KEPT SMOOTH. AT EVERY FOURTH COURSE THE BRICKWORK IS MODIFIED TO INCLUDE A "TOOTH" WHICH WILL LATER FORM THE CONNECTION BETWEEN THE VENT PIPE AND THE WALL OF THE SUPERSTRUCTURE. THESE ARE SHOWN IN THE DIAGRAM,

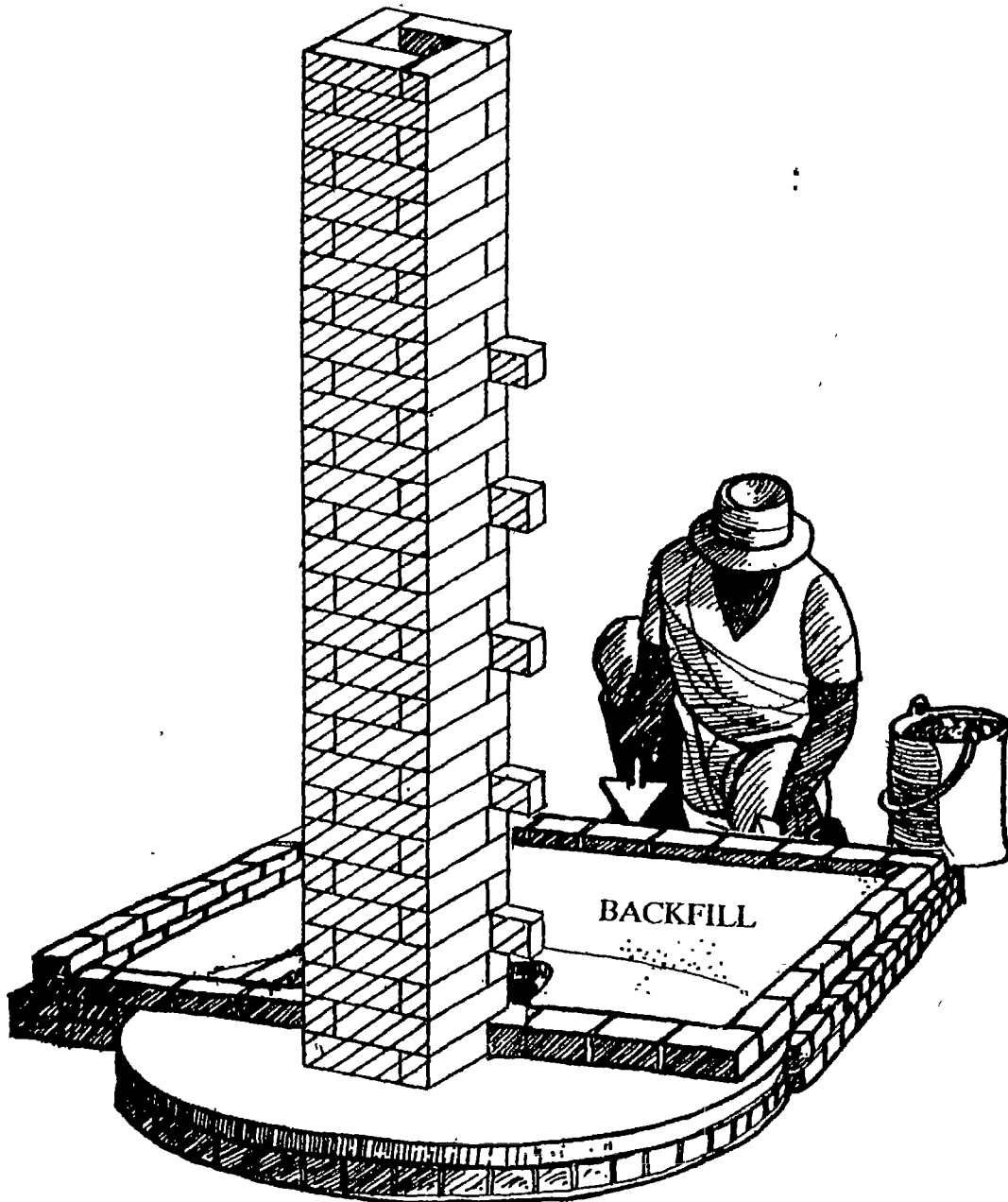

BACKFILL THE SPACE BETWEEN THE FOUNDATION AND THE COVERS LAB WITH HALF BRICKS, STONES OR WELL RAMMED SOIL. LEVEL OFF TO HEIGHT OF THE SLAB.

**STAGE 10. BUILDING THE SUPERSTRUCTURE**

**THIS IS MADE WITH FIRED BRICKS BONDED WITH ANTHILL MORTAR. THE ANTHILL MORTAR MAY BE MIXED WITH SAND OR COWDUG TO MAKE MORE SUITABLE FOR MORTAR WORK. THE SUPERSTRUCTURE WALL IS BONDED TO THE VENT PIPE THROUGH THE TEETH PREVIOUSLY MADE ON THE PIPE.**

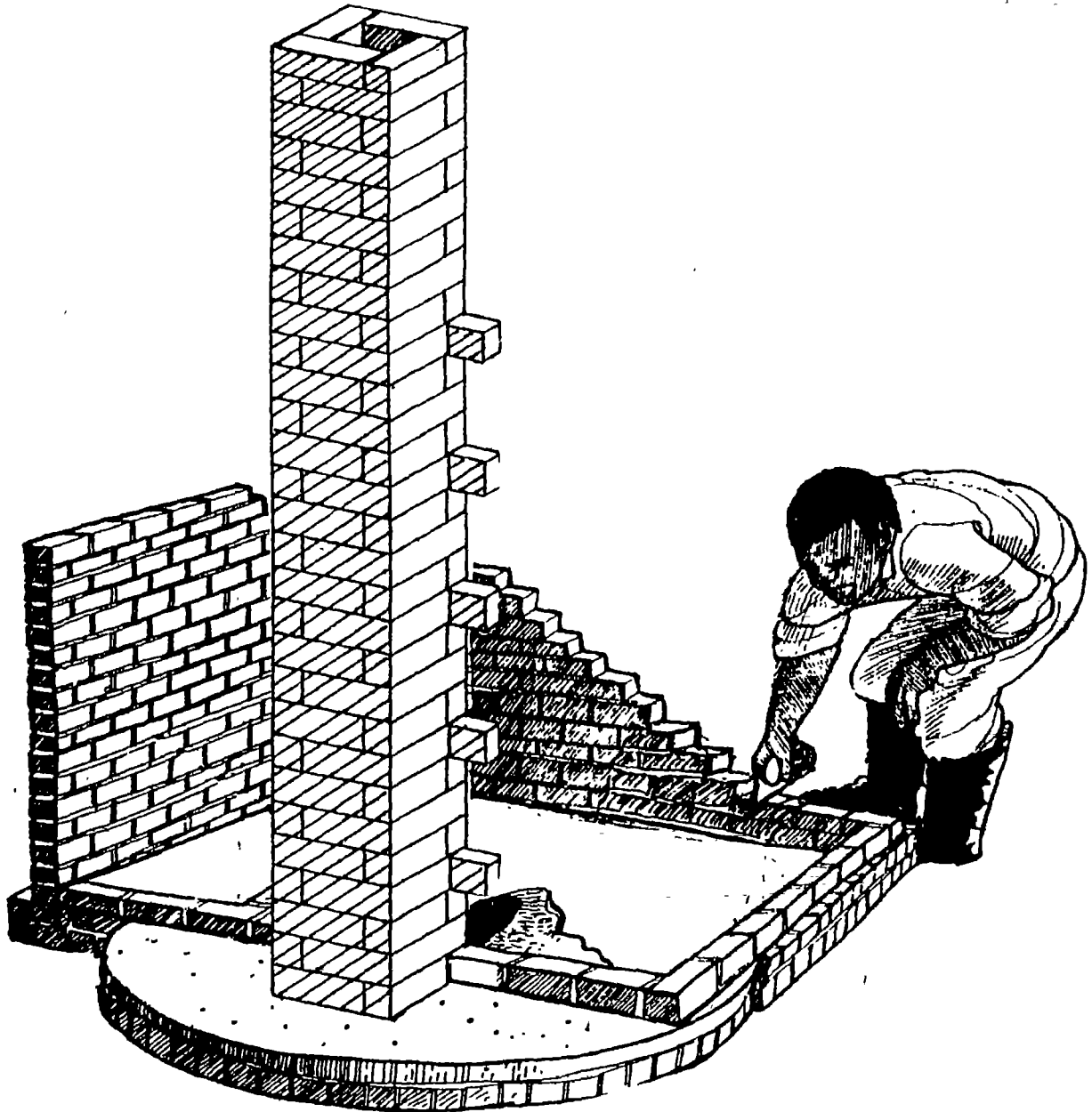

**THE WALL IS BUILT UP TO A HEIGHT OF 1.8m (WHICH IS ABOUT 21 COURSES OF BRICKS)**

**WHEN THE SUPERSTRUCTURE IS FINISHED THE INSIDE WALL IS PLASTERED WITH CEMENT MORTAR USING A MIXTURE OF 8 PARTS PIT SAND & 1 PART CEMENT. THIS PROTECTS THE WALL FROM THE WASHING WATER USED IN THE LATRINE.**

### STAGE 11. MAKING THE LATRINE FLOOR

ONCE THE BRICK WALLS HAVE BEEN BUILT AND PLASTERED THE LATRINE FLOOR CAN BE MADE. THE CONCRETE FOR THE FLOOR IS MADE WITH 4 PARTS RIVER SAND & 1 PART CEMENT. THE CONCRETE IS LAID SO THAT IT SLOPES DOWN FROM THE BRICK STEP AT THE ENTRANCE TO THE SQUAT HOLE. IT IS FINALLY SMOOTHED DOWN WITH A STEEL FLOAT

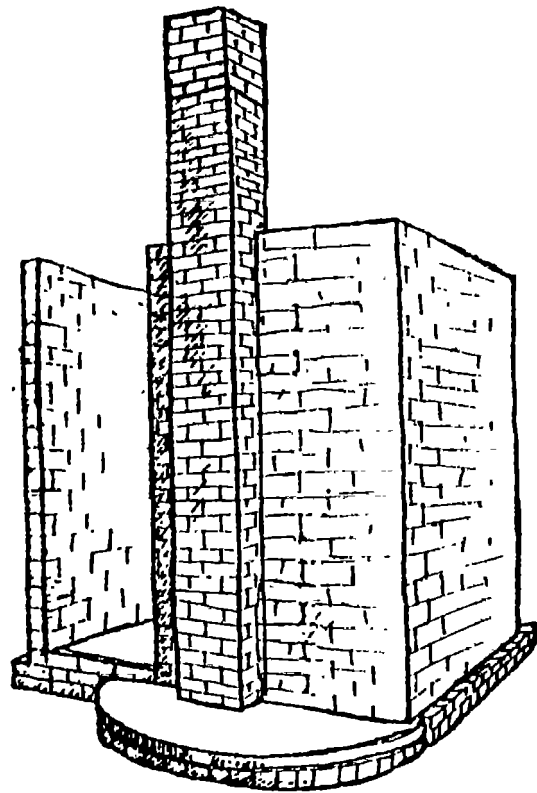

### STAGE 12 MAKING THE FERROCEMENT ROOF

A FERROCEMENT ROOF IS MADE TO THE MEASUREMENTS SHOWN BELOW WITH A MIXTURE OF 3 PARTS WASHED RIVER SAND & 1PART CEMENT. THE ROOF SHOULD BE MADE OVER A SHEET OF PLASTIC. THE MOULD CAN BE MADE OF BRICKS. CHICKEN WIRE IS USED AS REINFORCING. A RECESS IS MADE FOR THE VENT PIPE. THIS SHOULD BE MEASURED ON SITE. THE ROOF IS CURED FOR 7 DAYS & KEPT WET AT ALL TIMES.

**NOTE:** THE MEASUREMENTS SHOWN BELOW MUST BE USED AS GUIDES ONLY.

THE EXACT MEASUREMENTS FOR THE ROOF SHOULD BE TAKEN FROM THE ACTUAL STRUCTURE ALLOWING FOR A 50MM OVERLAP ALL AROUND.

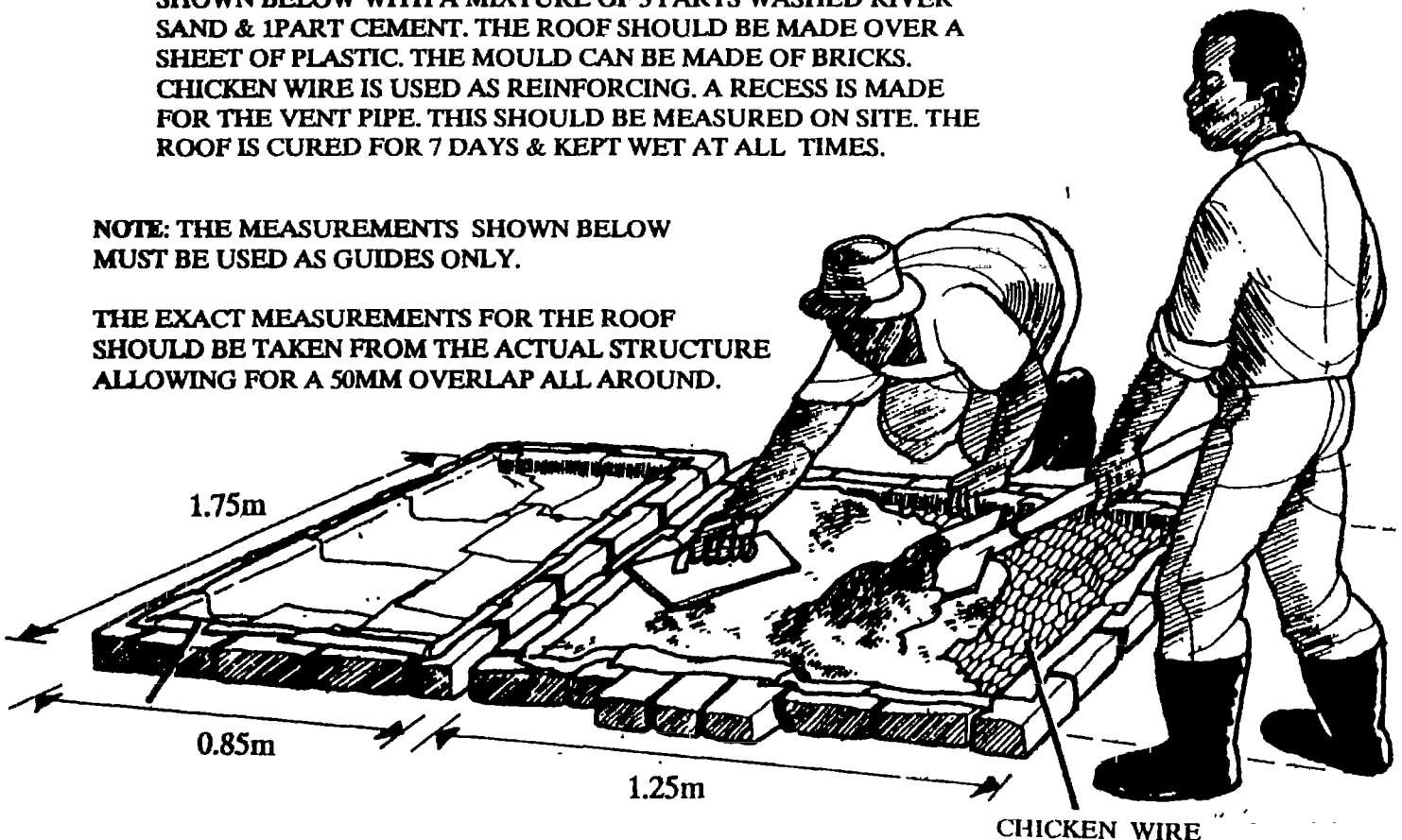

**STAGE 13 ADDING THE ROOF**

**THE TWO PARTS OF THE FERROCEMENT ROOF ARE CAREFULLY LIFTED, WASHED DOWN & FITTED TO THE STRUCTURE IN A BED OF CEMENT MORTAR**

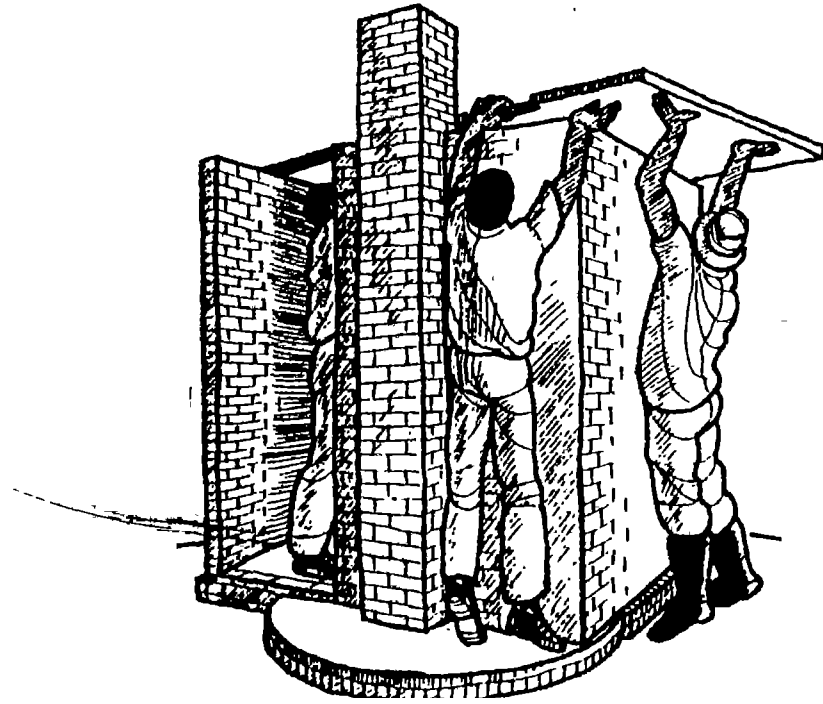

**STAGE 14. FITTING THE FLYSCREEN**

**THIS IS A VERY IMPORTANT PART OF THE LATRINE AND CONTROLS FLIES. THE SCREEN SHOULD BE MADE OF STAINLESS STEEL OR ALUMINIUM. THE SCREEN SIZE IS 225mm X 225mm. IT IS FITTED TO THE HEAD OF THE VENT PIPE IN STRONG CEMENT MORTAR.**

**CLEAN SCREEN CAREFULLY OF ANY MORTAR & DEBRIS TO ENSURE A GOOD AIR FLOW.**





# METHODS OF UPGRADING THE "4 BAG" MODEL

**1. POINT THE ANTHILL MORTARED  
BRICKWORK WITH CEMENT MORTAR  
TO A DEPTH OF ONE CM.**

**OR**

**2. PLASTER THE EXTERNAL  
WALLS OF THE LATRINE  
WITH CEMENT MORTAR**

**PLANT GRASS  
AROUND  
LATRINE TO  
REDUCE EROSION**

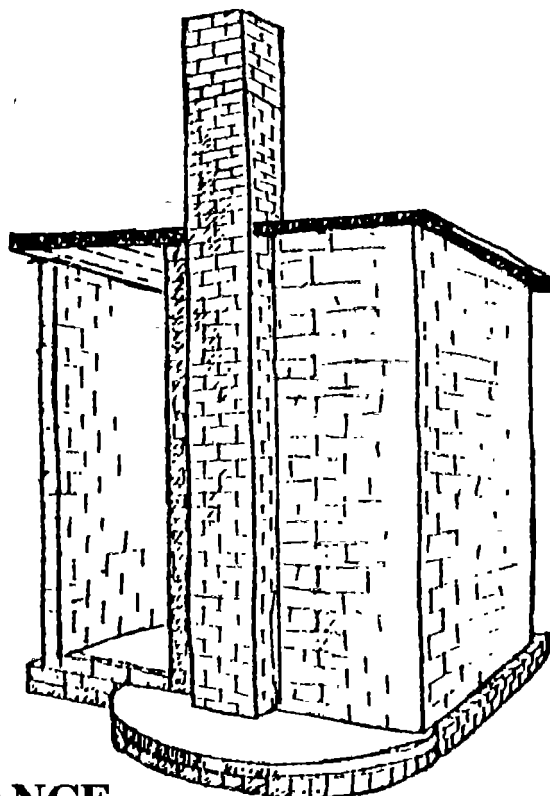

## MAINTENANCE

**THE MOST IMPORTANT MAINTENANCE OF THE BLAIR LATRINE IS TO KEEP THE INSIDE CLEAN BY WASHING WITH WATER. WASH DOWN THE LATRINE SLAB EVERY DAY IF POSSIBLE. INSPECT THE FLYSCREEN EVERY SIX MONTHS TO SEE IF IT IS UNDAMAGED.**

## DAILY USE

**USE THE LATRINE AS A BATHROOM. IF POSSIBLE BUILD A HANDWASHING TANK ON THE LATRINE. GOOD HEALTH COMES FROM GOOD HYGIENE.**

## DIMENSIONS OF SLAB AND STRUCTURE

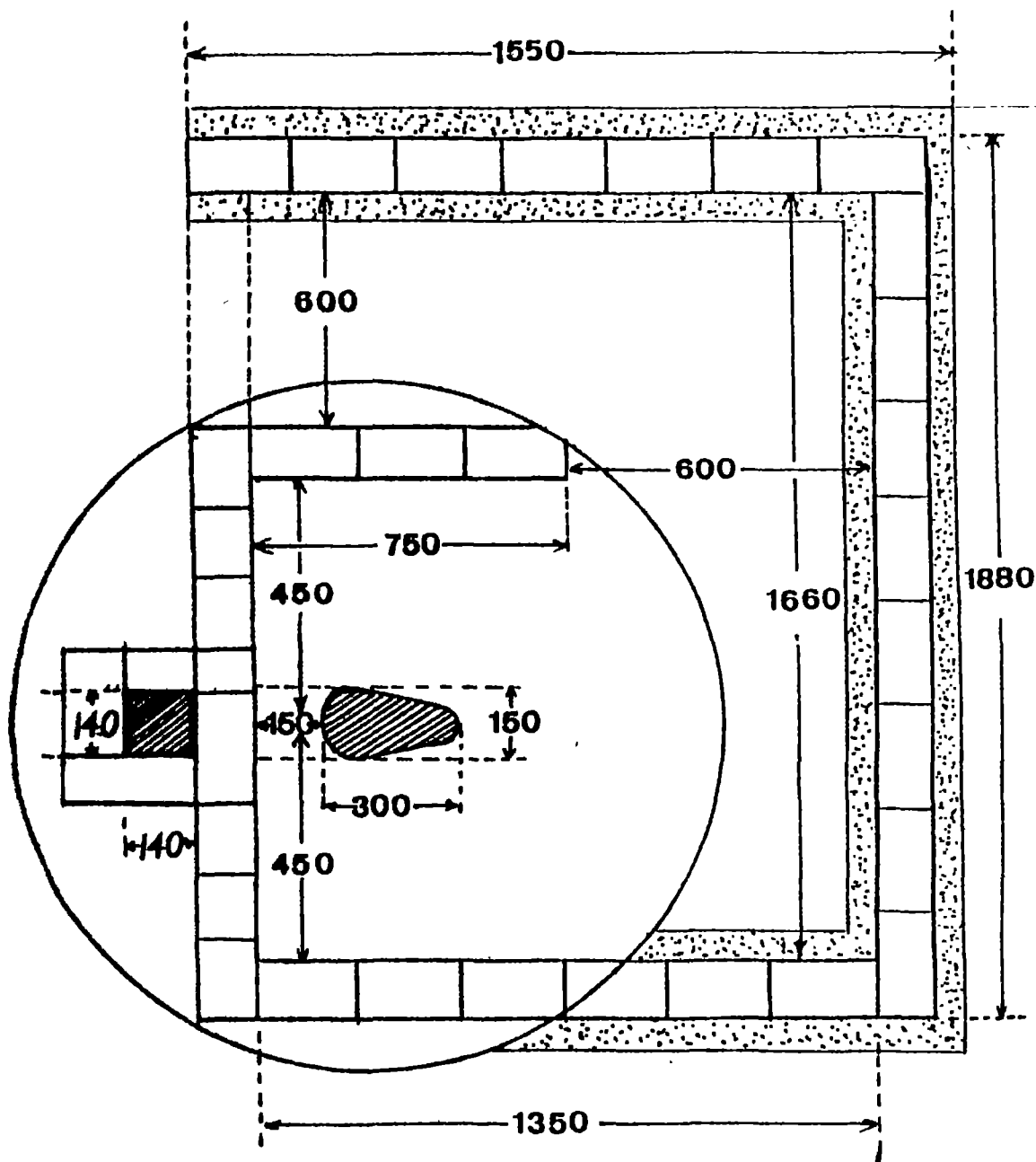

THE DIAMETER OF THE CONCRETE SLAB IS 1.3m AND IS PLACED OVER A BRICK LINED PIT WITH AN INTERNAL DIAMETER OF 1.1m. THE PIT IS 3m DEEP. THE FOUNDATION SHOWN ABOVE AS THE DOTTED AREA IS 225mm WIDE. THE BRICK WALLS ARE A SINGLE BRICK THICKNESS. THE SQUAT HOLE IS APPROXIMATELY 125mm WIDE AND 275 - 300 mm LONG. THE VENT PIPE HOLE MEASURES 140mm X 140mm. THE BRICK VENT HAS THE SAME INTERNAL SIZE.

## **INTRODUCTION TO THE HAND WASHING TANK**

The regular use of the Blair Latrine, together with improved access and use of safe water are essential components of an improved hygienic way of life. They form the cornerstones on which all public health is built. Yet the full benefits of safe water and improved sanitation cannot be attained unless each person is able to wash thoroughly each day.

One of the most important aspects of improved bodily hygiene is handwashing. The hands should be thoroughly washed several times during each day. Most important the hands should be washed before and after eating each meal, and also after each visit is made to the toilet.

Very large numbers of Blair Latrines have now been built in Zimbabwe. They are very popular because they are almost odour free and also control flies. Because they do not smell and offer a convenient place of privacy they are often used as wash rooms- and thus their usefulness is increased. However at the present time very few Blair Latrines are built with an easy access to a handwashing facility. Where handwashing is difficult the full benefits of improved sanitation can never be attained.

This part of the manual describes how a strong and permanent handwashing facility can be built onto a standard Blair Latrine at minimum cost. The facility consists of a small tank built from cement, sand and bricks which forms a reservoir on the side of the latrine. A small copper tube is introduced through the wall of the tank to control the flow of water. The flow is stopped by introducing a small plastic covered wire or rubber plug into the end of the tube.

One eighth of a bag of cement is required (one five litre tin) and a small piece of thin copper tubing. A few fired bricks, some pit and river sand a few strands of thin wire are also needed for reinforcing. A short length of 3mm wire is also required for the handle of the tank's cover.

Once the facility is built and a week is allowed for curing, the plug is introduced into the copper tube which acts like a spout allowing a controlled amount of water to drain from the tank. Once the hands are washed, the plug is introduced back into the copper tube. Thus the tube and plug act like a tap.

If carefully used, one filling of the handwashing tank with water can give several days of use before it requires topping up. A bar of soap can be conveniently left of the top of the facility.

The regular use of this simple facility greatly improves personal hygiene and is recommended for use on all Blair Latrines.

## STAGES IN THE CONSTRUCTION OF THE HANDWASHING FACILITY

### STAGE 1.

CUT A SLOT WITH A HAMMER AND CHISEL ONE METRE ABOVE THE LATRINE SLAB LEVEL IN THE PLACE INDICATED ON THE DIAGRAM. THE SLOT SHOULD BE ABOUT 20MM DEEP. THE REINFORCED CONCRETE BASE SLAB OF THE TANK WILL FIT INTO THIS RECESS.

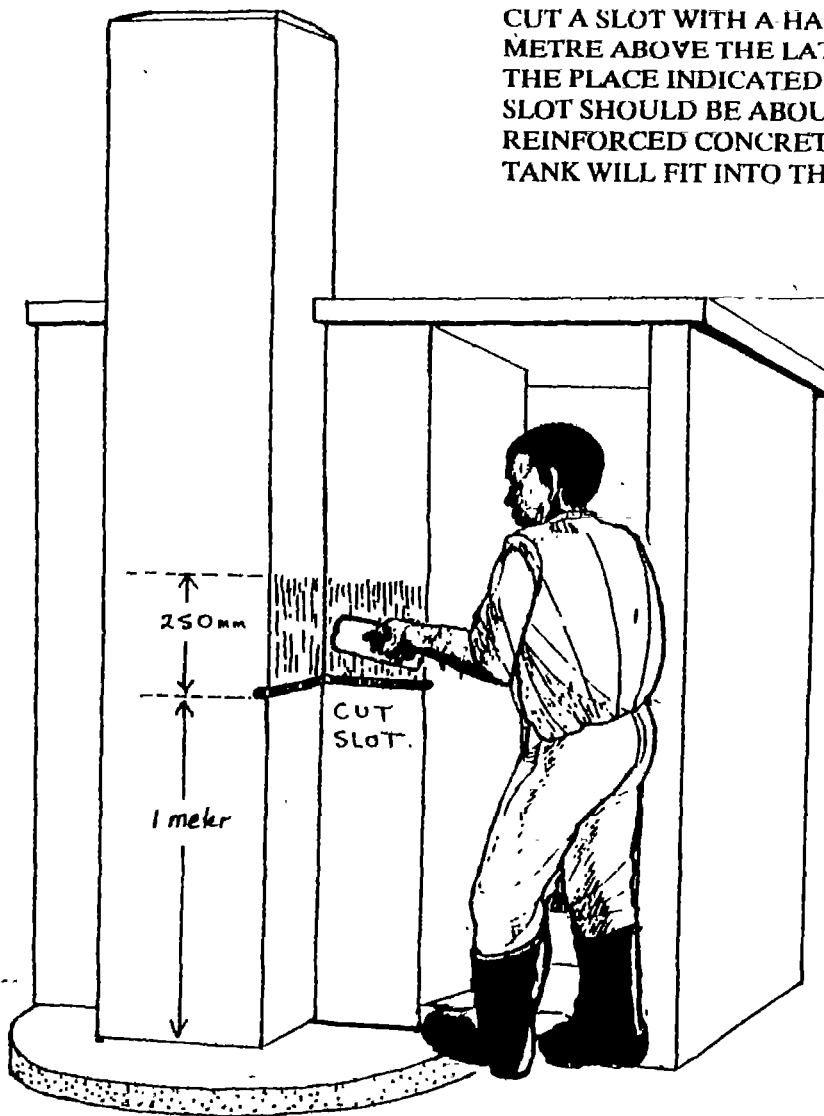

### STAGE 2.

MIX 0.5 LITRES OF CEMENT WITH 1.5 LITRES PIT SAND AND APPLY THE MORTAR ABOVE THE SLOT TO A HEIGHT OF ABOUT 250MM. THIS ACTS AS A WATER PROOF LAYER OF THE TANK AND IS EASIER TO APPLY AT THIS STAGE.

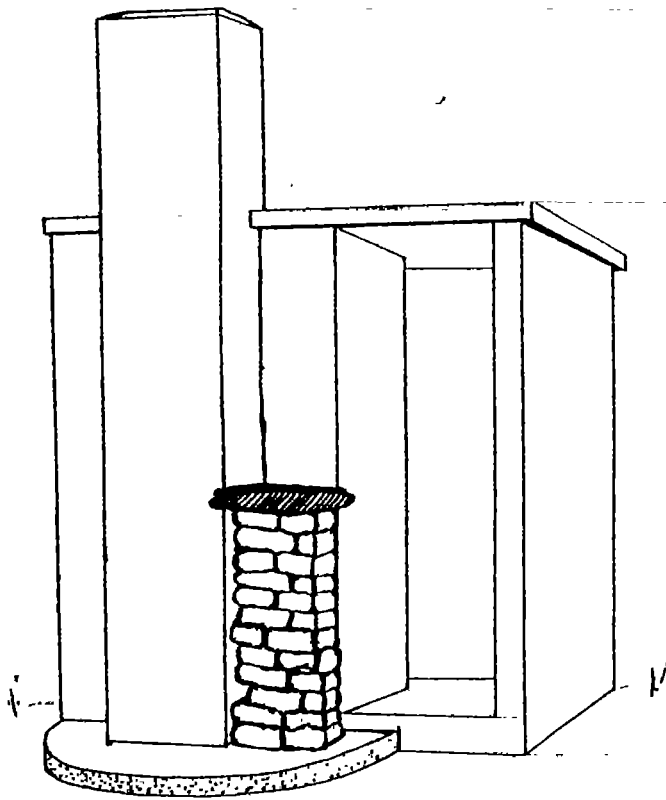

**STAGE 3.**

**BUILD UP A LOOSE PILE OF BRICKS TO SUPPORT A TIN SHEET JUST BELOW THE LEVEL OF THE SLOT. THIS WILL FORM THE BASE UPON WHICH THE CONCRETE BASE OF THE TANK WILL BE BUILT.**

**STAGE 4.**

**MIX 1.5 LITRES OF CEMENT WITH 4.5 LITRES RIVER SAND AND BUILD UP A LAYER OF CONCRETE ON THE TIN SHEET ABOUT 40MM THICK. THE CONCRETE SHOULD ENTER THE SLOT CUT INTO THE LATRINE WALL. ADD SEVERAL LENGTHS OF THIN REINFORCING WIRE INTO THE MIXTURE. SHAPE THE CONCRETE IN A CURVE ON THE OUTER FACE.**

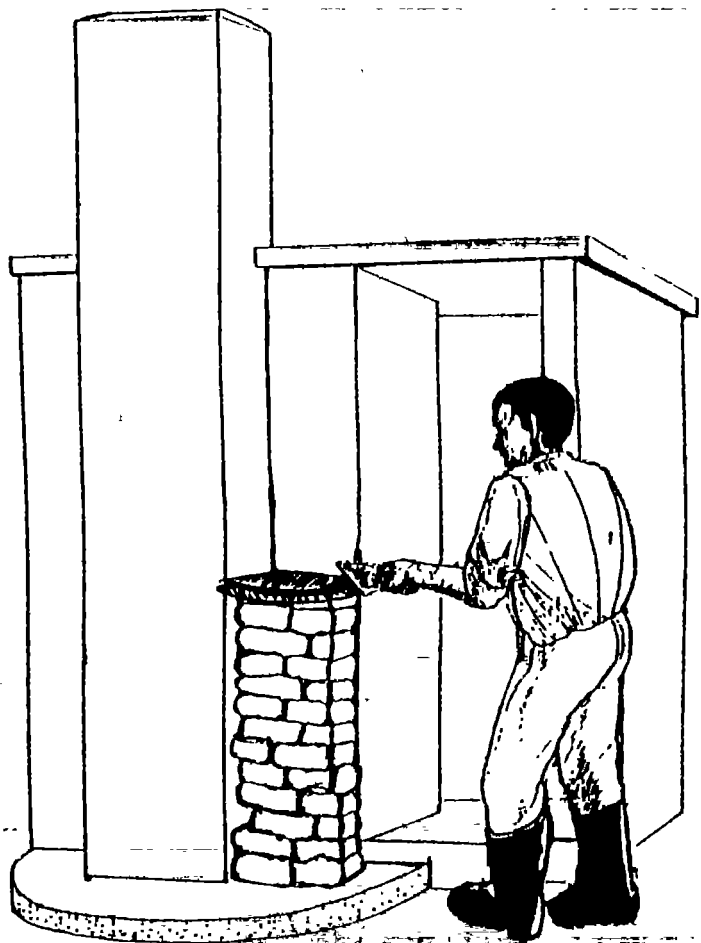

**STAGE 5.**

**CUT TWO BRICKS IN HALF ALONG THE LENGTH OF THE BRICK SO THAT 4 HALF BRICKS WILL BE MADE. THREE OF THESE WILL BE USED TO MAKE THE OUTER WALL OF THE TANK.**

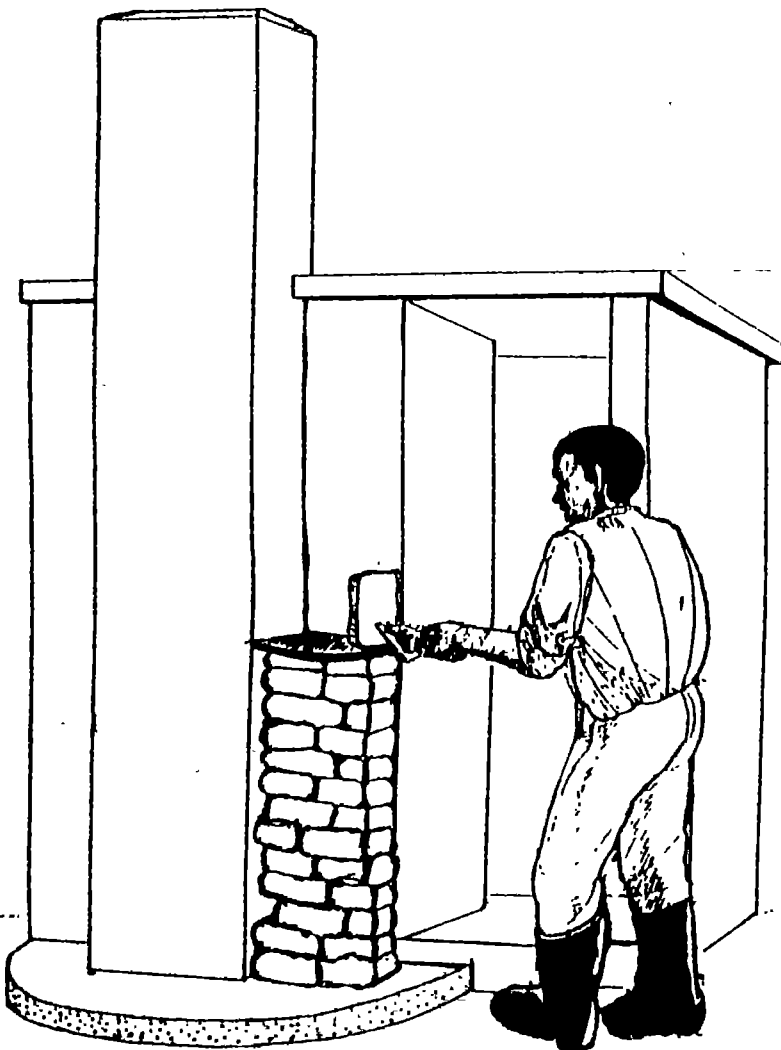

**STAGE 6.**

**MIX 0.5 LITRES CEMENT WITH 1.5 LITRES PIT SAND. USING THIS MORTAR AS BONDING ADD EACH BRICK UPRIGHT AS SHOWN IN THE DIAGRAM. THREE BRICKS ARE REQUIRED TO COMPLETE THE OUTER WALL.**

**STAGE 7.**

ONCE THE THREE BRICKS ARE CEMENT MORTARED IN PLACE CUT 2 MORE SLOTS IN THE WALL OF THE VENT PIPE AND 2 SLOTS IN THE LATRINE WALL AS SHOWN IN THE DIAGRAM. CUT SOME WIRE AND NAIL THE ENDS OF EACH PIECE OF WIRE WITHIN EACH SLOT. TWO WIRES ARE REQUIRED. PLACE IN THE POSITION SHOWN. THESE WIRES SUPPORT THE BRICKWORK OF THE TANK.

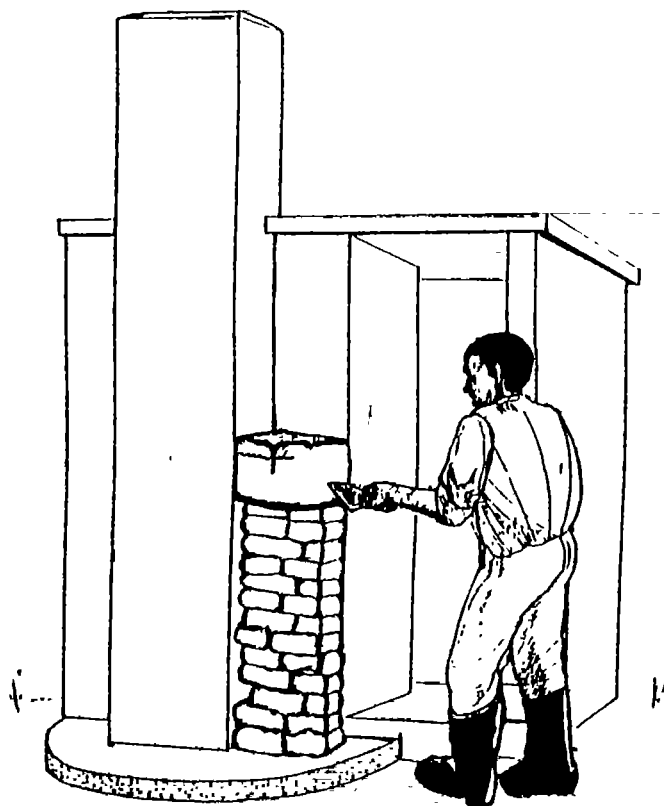
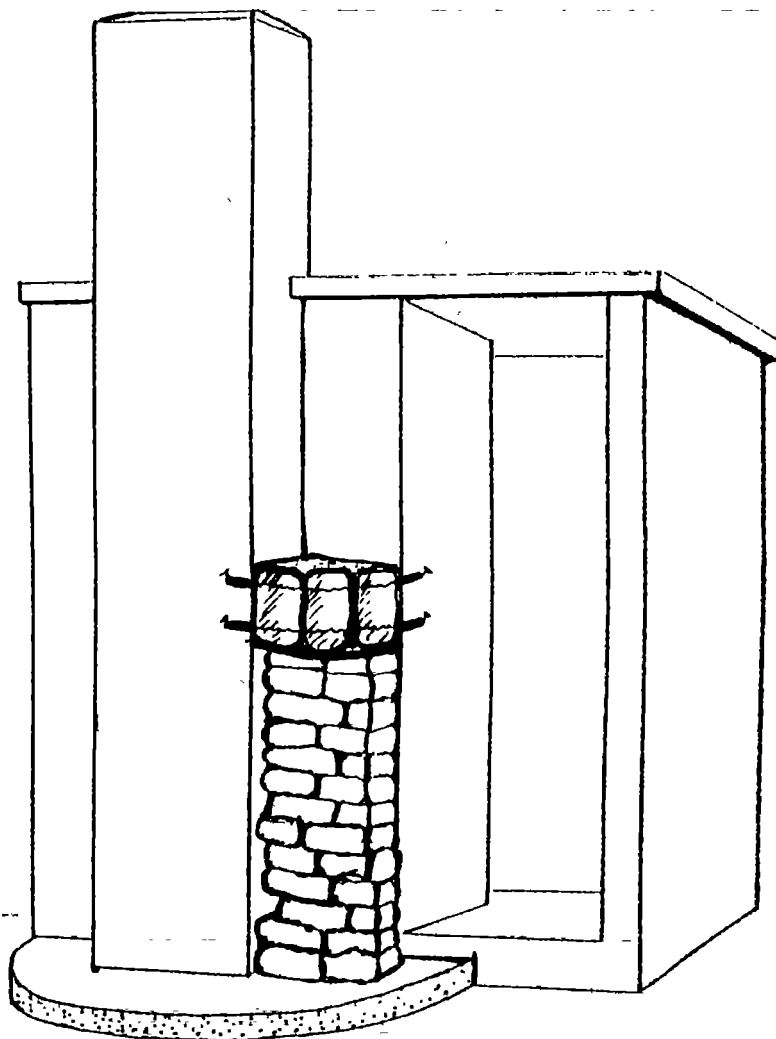

**STAGE 8.**

MIX A FURTHER 2 LITRES OF CEMENT WITH 8 LITRES OF PIT SAND. PLASTER THE OUTER WALL OF THE TANK. FOLLOW THIS BY APPLYING THE REST OF THE MORTAR TO THE INSIDE OF THE TANK SO THAT THE WALL IS THICK AND STRONG. MAKE THE INTERNAL PLASTER WORK AS SMOOTH AS POSSIBLE. PLASTER OVER THE WIRE INSERTS INTO THE WALL OF THE LATRINE.

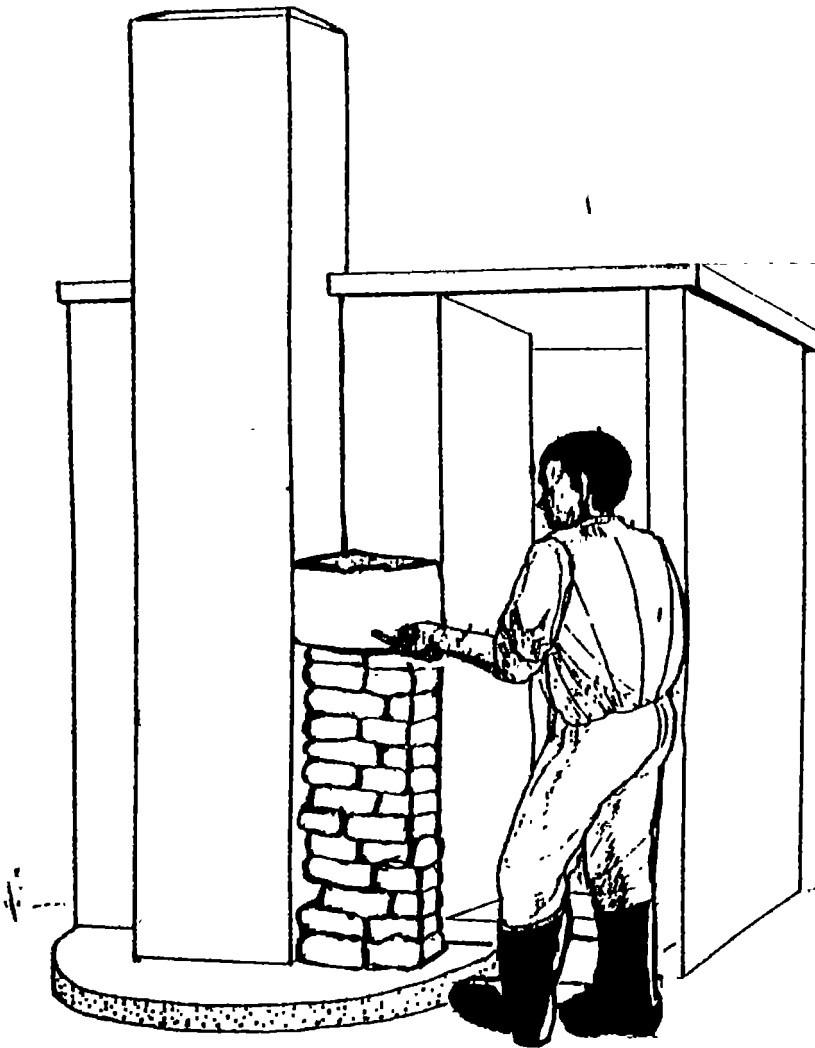

**STAGE 9.**

ADD THE COPPER TUBE. THE SMALL COPPER TUBE IS 125MM LONG AND PRESSED THROUGH THE WALL OF THE TANK AT A POINT BETWEEN THE BRICKS. THE TUBE IS PLACED LOW DOWN IN THE TANK, AND ABOUT 25MM ABOVE THE BOTTOM OF THE TANK. THE TUBE MUST BE SECURELY PLACED AND TIGHT WITHIN THE CEMENT MORTAR. THE TUBE SHOULD BE PLACED SO THAT IT SLOPES SLIGHTLY DOWNWARDS TO THE GROUND. THE TUBE IS BLOWN OUT BY MOUTH TO CLEAR ANY CEMENT INSIDE. THE CEMENT MORTAR AROUND THE TUBE IS TROWELLED FIRM. A WOODEN TWIG CAN BE FITTED TO THE TUBE FROM THE INSIDE TO REDUCE WATER FLOW AND CONSERVE WATER IN THE TANK.

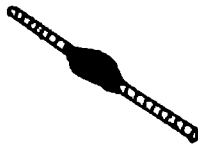

**Copper tube**

*note: in order to make the tube fit more securely in the tank wall a piece of trinepon putty is moulded and attached to the tube half way along its length.*

**STAGE 10.**

A PLASTIC BAG IS PLACED WITHIN THE TANK AND FILLED WITH SAND AND LEVELLED OFF AT THE UPPER END OF THE TANK. ADD A PIECE OF PLASTIC SHEET OVER THE TOP OF THE TANK. THE LID OF THE TANK WILL BE CASTE ON TOP OF THIS SHEET.

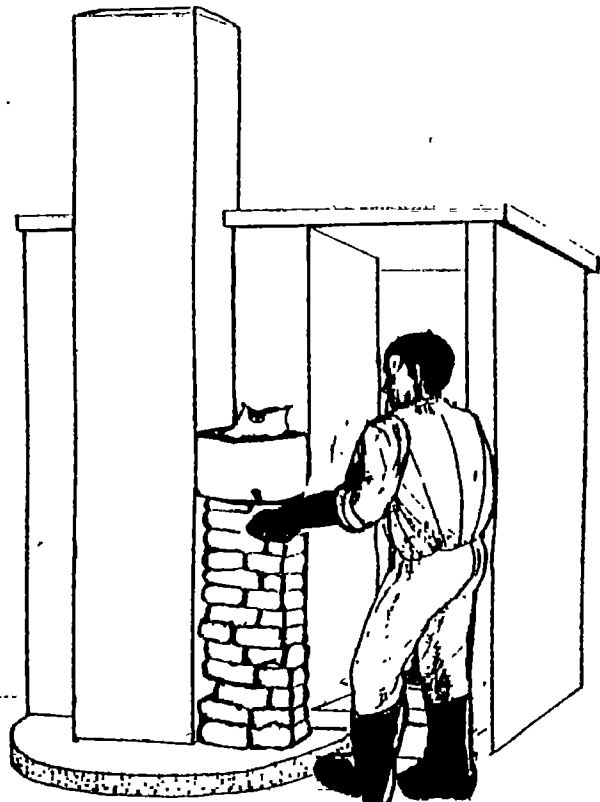



**STAGE 11.**

**MIX 1 LITRE CEMENT AND 3 LITRES RIVER SAND. USE THE MIXTURE TO BUILD THE LID OF THE TANK. FOLLOWING THE LINE OF THE TANK TO MAKE A NEATLY FITTING LID. ADD SEVERAL STRANDS OF THIN REINFORCING WIRE INTO THE MIXTURE. MAKE A HANDLE FROM 3MM WIRE.**

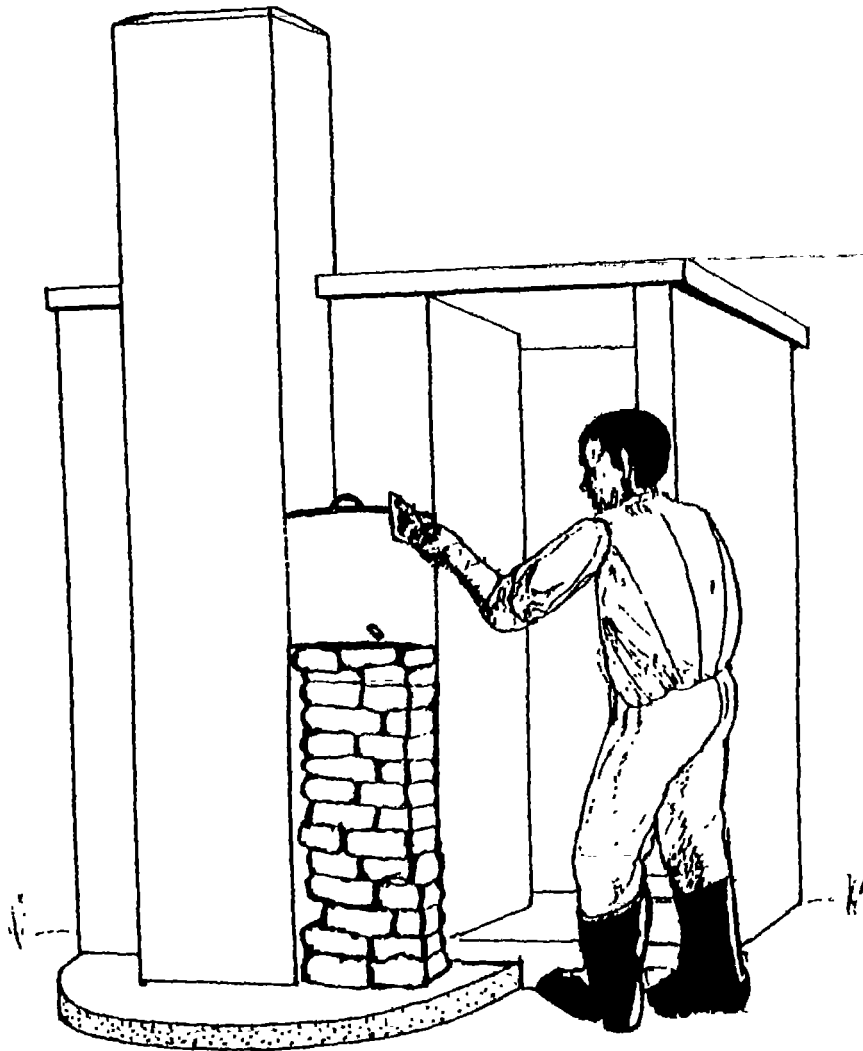

**STAGE 12.**

**ALLOW TO CURE FOR 5 DAYS. TAKE OUT THE SAND BAG. THOROUGHLY CLEAN OUT THE TANK SO THAT NO SAND OR GRIT REMAINS. BEFORE FILLING WITH WATER FIND A SUITABLE STOPPER FOR THE COPPER PIPE. THIS CAN BE MADE OF A WOODEN TWIG OR THICK GRASS STEM. IT CAN ALSO BE MADE OF RUBBER OR RUBBER COATED WIRE. THE TUBE SHOULD NOT DRIP ONCE THE TANK HAS BEEN FILLED WITH WATER AND THE STOPPER HAS BEEN FITTED. THE HANDWASHING FACILITY CAN THEN BE PUT TO USE.**

## **OPERATION AND MAINTENANCE OF THE HANDWASHING FACILITY.**

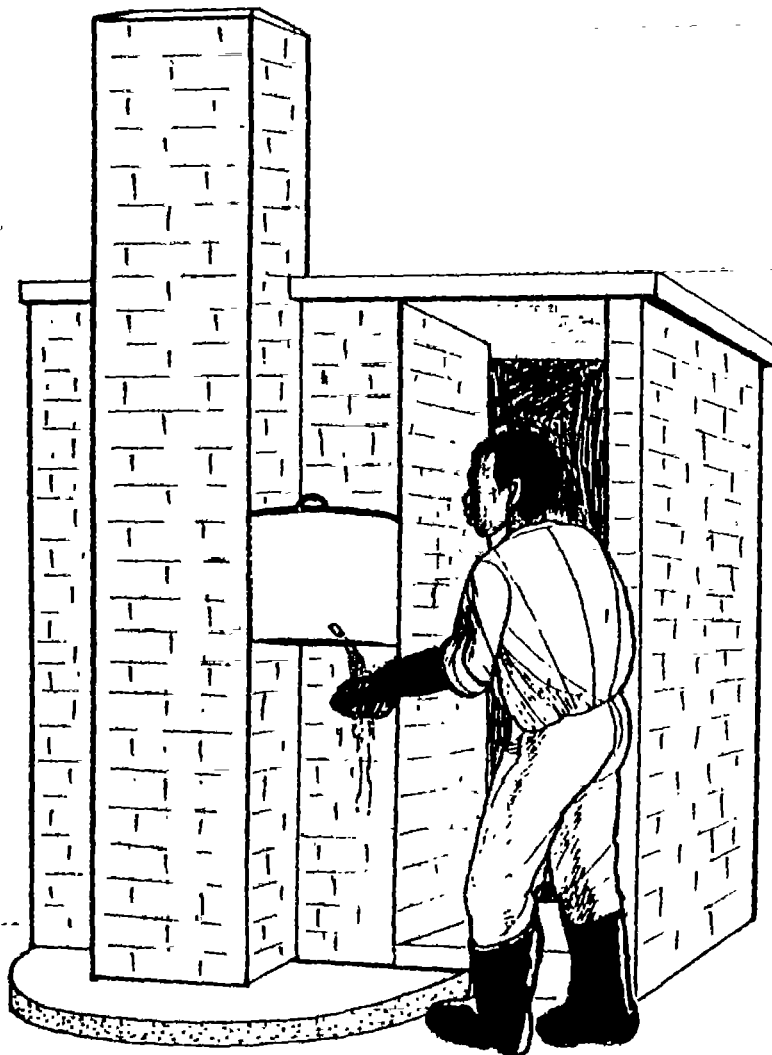

**ONCE THE HANDWASHING TANK IS CURED IT CAN BE PUT TO USE.**

- 1. THOROUGHLY WASH AND CLEAN OUT THE TANK AND WASH THE LID**
- 2. FIND A SMALL WOODEN STOPPER TO FIT IN THE END OF THE COPPER TUBE**
- 3. FILL UP THE TANK WITH WATER AND REPLACE THE LID**
- 4. USE THE TANK EVERY TIME YOU LEAVE THE TOILET**
- 5. PLACE A PIECE OF SOAP ON THE TANK COVER FOR REGULAR USE.**
- 6. PLACE SOME FLOWERS OR HERBS UNDER THE "TAP" TO USE WASTE WATER**
- 7. GET INTO THE HABIT OF REGULARLY FILLING THE TANK WITH WATER**
- 8. IF THE TUBE BECOMES BLOCKED CLEAR IT WITH A THIN WIRE**
- 9. REPLACE THE WOODEN STOPPER FROM TIME TO TIME**

**REMEMBER**

# **CLEAN YOUR HANDS OFTEN!**

# MAVOKO ANOBATA TSVINA YAKAWANDA

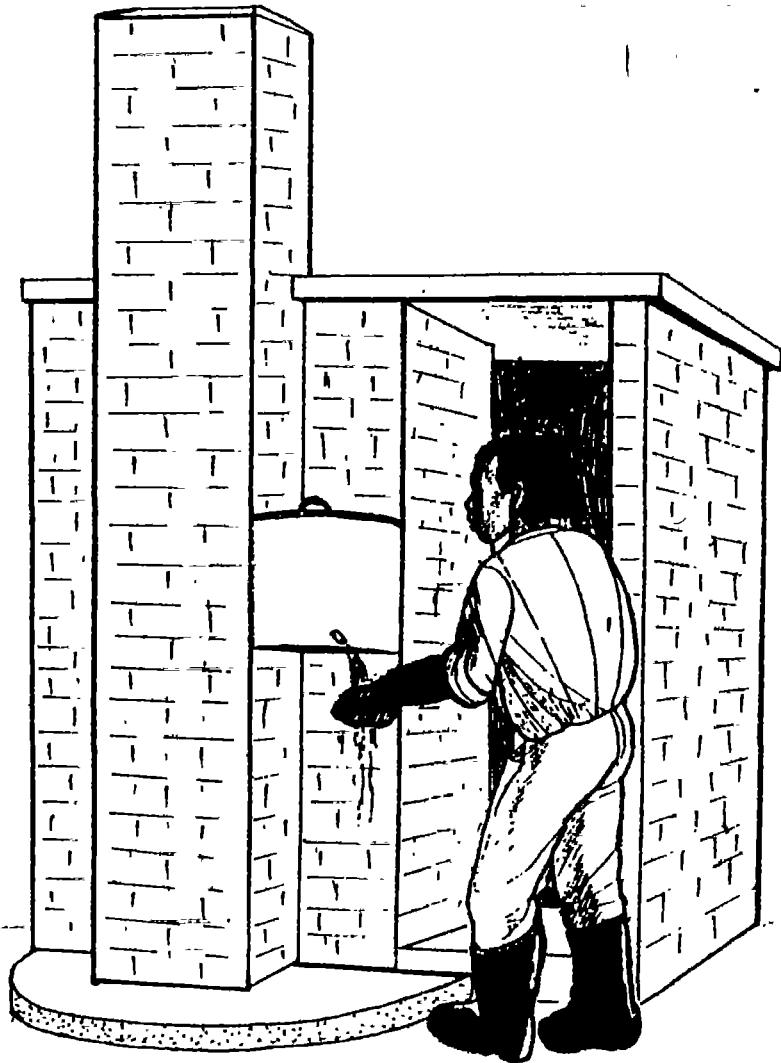

## NDEDZIPI - NGUVA DZATINOSUNGIRWA KUGEZA MAVOKO:

- NGUVA DZOSE TISATI TADYA
- NGUVA DZOSE TAPEDZA KUDYA
- TISATI TABATA CHOKUDYA CHOSE
- NGUVA DZOSE TABVA MUKUSHANDISA CHIMBUZI





