

262.0

82RE

s Horbartha



Water Supply Distribution Training Programme

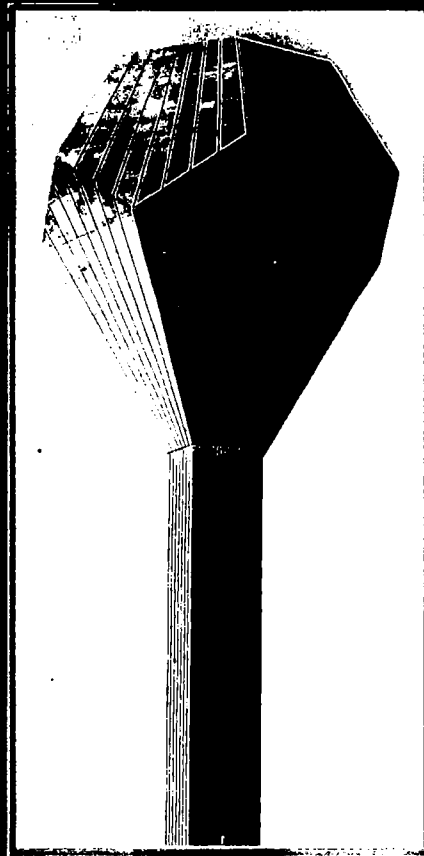
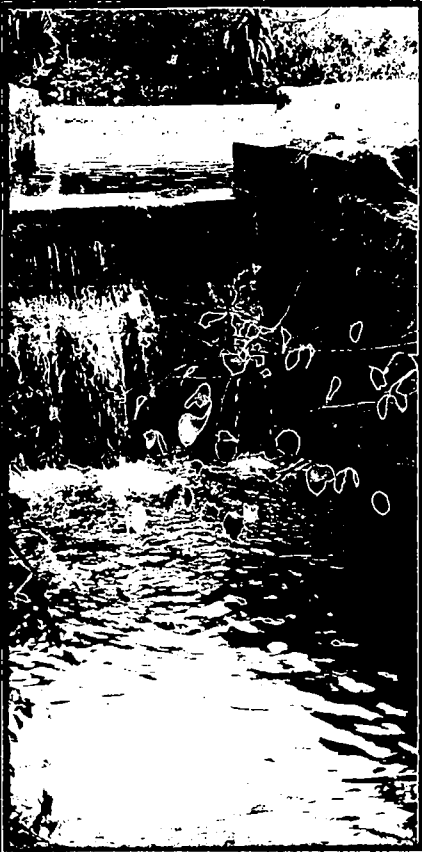

Manual

9

REGULATIONS FOR
INSTALLATION OF WATER SERVICES

262.0-82RE

An Foras Forbartha

KD 3505



262.0
82 RE

Water Supply Distribution Training Programme

LIBRARY
International Reference Centre
for Community Water Supply

Manual

9

REGULATIONS FOR INSTALLATION OF WATER SERVICES

E. Lacey

Information and Training Centre
An Foras Forbartha
St. Martin's House
Waterloo Road
Dublin 4
Ireland

June, 1982

ISBN 0 906120 65 9

Telephone (01) 764211
Telex 30846

CONTENTS

Page

Preface

Regulations for the Installation of Water Services

1

Appendix 1

5

Appendix 2

7

PREFACE

An Foras Forbartha provides an extensive programme of courses and continuing education for engineers. Some courses are presented as discrete events; others are grouped to provide more comprehensive training in the various aspects of a particular subject area.

This manual, one of a series for engineers involved in water distribution, is designed to provide course participants with a concise reference source. The manuals are intended also as aids to the practising engineer, who can use them to supplement his own knowledge in a particular area. Because of their brevity the manuals are not intended to be used as a replacement for text books.

There are nine manuals in this series covering the following topics:

- Strategic Planning of Water Supplies
- Design and Analysis of Water Distribution Systems
- Materials Selection and Specification
- Control of Water Waste
- Pumps
- Water Quality
- Project Management
- Operation and Maintenance of Water Distribution Systems
- Regulations for Installation of Water Services

Further information on the courses and manuals may be obtained by writing to the address below.

Information and Training Centre
An Foras Forbartha
St Martin's House
Waterloo Road
Dublin 4
Ireland

Telephone 01/764211

Telex 30846

REGULATIONS FOR THE INSTALLATION OF WATER SERVICES

A water supply agency must have as its primary function the supply of potable water in sufficient quantity for use by its domestic consumers. In order to perform this duty efficiently the agency must prevent:

- (1) Waste
- (2) Undue Consumption
- (3) Misuse
- (4) Contamination
- (5) Erroneous measurement of the water supplied

To achieve this it is necessary to have regulations which may cover such items as:

- (a) Persons who may install water supplies
- (b) Methods of installations
- (c) Size/Type/Strength of materials to be used
- (d) Provision for inspection of work
- (e) Use to which water supplied may be put
- (f) Penalties for non compliance with regulations.

Provision of a water supply to a domestic consumer can be considered under two phases.

Phase (1)

The phase from when a supply is requested up to the time when the water is actually turned on

Phase (2)

The phase subsequent to the provision of water

In considering phase (1), with regard to the prevention of waste, undue consumption, misuse, contamination and erroneous measurement, it is a well established fact that bad workmanship, improper practices, use of improper or inadequate fittings/fitments at this, the installation stage, may have serious consequences in the long term. It is also a fact that the agency is in a position during this phase to exert the most control. While it is reasonably easy to refuse supply for non compliance with regulations, it is a different matter to disconnect a consumer once he has been supplied. Control at this stage may be achieved by:

- (1) Licensing contractors who provide supplies
- (2) Inspecting the workmanship and materials before actually turning on supply
- (3) Alternatively providing the supply using the agency's own trained personnel
- (4) Combinations of (1), (2) and (3).

During this phase, since the potential consumer must fill out an application form and pay if necessary the required connection fee, the opportunity should be taken to acquaint him with the conditions of supply. This is best done by making it part of the application

form and supplying the potential consumer with a copy when he signs the form (Appendix 1).

In considering phase (2) if the consumer causes waste, undue consumption, misuse, contamination or erroneous measurement, there must be some mechanism for regulating this.

The usual method is to enforce some form of penalty thus causing the consumer to desist.

FRAMEWORK

Before considering the subject of penalties it is first necessary to look at the wider aspect of water supply. With regard to the provision of water there are a number of possibilities:

- It can be treated as a business and handled by private enterprise with the consumer paying the full economic charge for the service provided
- It can be regarded as a social service essential to public health provided by the government or its delegated agents and subsidised by the state
- It can be provided by a mixture of public and private enterprise acting within a legal framework provided by the state. The service in this case may or may not be subsidised

PENALTIES

When considering penalties the options available will depend on the framework above.

A number of possible penalties for breaking regulations are listed below:

- (a) Disconnection with all costs recovered when connection is re-made
- (b) Court actions, where regulations have legal standing, resulting in a fine
- (c) Entering offenders premises and repairing or altering offending part of system and charging consumer for same
- (d) Rationing supply either to individual offender, or to whole area thus bringing community pressure to bear
- (e) Reducing pressure to individual or to local area.
- (f) Metering individual offender allowing him a reasonable quantity at a reasonable rate and charging any quantity in excess at a higher rate. Also charge for cost of metering
- (g) Serving a notice stating a time limit within which the consumer must desist from causing waste etc., and stating which of the above penalties will be applied if he fails to comply

The actual penalties which can be applied are dependent on the framework above under which the supply is provided.

Whatever penalties are catered for they must:

- (a) be enforceable
- (b) be enforced

Otherwise the regulations will fall into disrepute and their preparation will be a waste of time and effort.

REGULATIONS

Regulations may take various forms either the detailed form shown in Appendix 2 which were prepared for the State of Bahrain or they may take a less detailed form which may only consist of a form similar to Appendix 1 backed up by tradition. The detailed regulations Appendix 2 have the advantage that they form a code of practice for contractors making installations. One danger with detailed regulations is that they may preclude the use of new technology and materials if they are not drafted carefully. In the regulations in Appendix 2 this is catered for in clauses such as 2.3, 3, 10.3. This can be a major problem if regulations are made into bye-laws in which case the procedure to change them, often is involved, lengthy and cumbersome.

The following are a number of clauses taken as typical examples from the regulations Appendix 2 illustrating how the regulations are framed to prevent waste, undue consumption, misuse, contamination and erroneous measurement.

WASTE

Clause 55

"Every cold water storage cistern shall comply with the following requirements:

- (a) It shall be fitted with an efficient warning pipe of a corrosion resisting material and with no other overflow pipe if its capacity is less than 4.5 cu.m."

Definition 1.20

" 'Warning Pipe' means an overflow pipe so fixed that its outlet, whether inside or outside a building, is in a conspicuous position where the discharge of any water therefrom can readily be seen."

The need for the above regulation is to make it obvious to the consumer that an overflow is occurring so that steps may be taken to eliminate a source of waste.

UNDUE CONSUMPTION

Clause 57

"Hot Water Apparatus

Distance between hot water apparatus and draw-off taps"

Clause 57.1

"The length of any pipe conveying hot water from any hot water apparatus, hot water storage cistern, cylinder or tank, or flow and return system to any draw-off tap shall be as short as possible and shall be lagged."

The objective of the above regulation is to prevent undue consumption by the consumer running the water which has cooled in pipelines to waste, until water of the required temperature arrives.

MISUSE

Clause 33.1

"Every premises supplied with water by the water supply directorate or from a private source shall be supplied by a separate service pipe, which shall not communicate with or supply water to any other premises . . ."

The objective of this clause is to prevent misuse by allowing the agency the ability to curtail the consumers supply in the event of misuse of water. Misuse may be defined in more detail on the application form which the consumer receives when applying for a supply. It is desirable although not essential that it should also be defined in the regulations. Misuse may cover such items as:

- (a) Extending the supply to another premises
- (b) Using water for a purpose for which it is not intended i.e. car washing, watering gardens etc.

CONTAMINATION

Clause 14.2

"The connection from a service pipe to any cistern shall discharge freely into the cistern at least 150mm above the highest possible water level in that cistern."

The objective of this clause is to prevent the danger of contamination due to back siphonage which could occur if discharge point was below top water level.

ERRONEOUS MEASUREMENT

Clause 80.1

"Where the laying on of a new supply has been agreed by the water supply directorate, the directorate will lay the service pipe from the water main to the consumer's stopcock for a standard fee. The consumer must provide and fit, at his own expense, an approved type meter box, which shall be mounted as shown in Appendix 2.2, Sketch 3 of these regulations."

The objective of this clause particularly the latter part is to ensure that the meter is so positioned that (a) it will operate correctly and (b) any tampering with it will be obvious immediately.

The above examples are only some of the many clauses which are designed to prevent waste, undue consumption, misuse, contamination or erroneous measurement.

Regulations should also deal with commercial and industrial users where they are permitted. They should include provision for internal boosting where mains pressures are not adequate such as in multistorey blocks. They should also include for private supplies in areas where private abstractions have to be controlled.

Detailed examination of Appendices 1 and 2 will show the diversity of items that need to be covered to produce a good set of regulations. These examples are obviously not suitable for universal application as regulations like all other facets of water distribution must be tailored to suit the particular areas under consideration. It is important particularly in drawing up Regulations or Conditions of Supply to ensure that they comply with the legal framework within which the water supplying agency operates.

Appendix 1

WATER SUPPLY AUTHORITY

Form 1A

APPLICATION FORM FOR A WATER SUPPLY

(Please use block capitals)

1. I (Name)
of (address for correspondence)
.
.
make application for a water connection and supply at (address of required connection)
.
.

2. I require the supply for: (Please tick correct box)
(a) A dwelling house []
(b) An outside tap/standpipe []
(c) A field (for use for watering stock) []
(d) Other (specify)
The point at which I require the water is approximately
distance from the Authority's main at
.

3. I agree to
(a) Pay the connection fee of
(b) Pay the relevant charges for water as are in force at the time of billing, currently
(c) Be bound by the Authority's Regulations and Conditions of Supply (i).

Signed
Date

For Office Use: (ii)
a What diameter of connection is required
b What diameter of pipe is required from point of connection to point of supply
c What is the estimated water requirement of this connection
d Will the supply require metering
If so, what size of meter is required

(i) Copies of the Conditions of Supply and Regulations may be viewed in the Authority's offices at any time during working hours. Copies are also available on payment of the sum of An outline of the Conditions of Supply is also attached with this form.
(ii) For office use and to enable applicant to procure correct size of fittings this section should be completed by a technically qualified person with good knowledge of the system where connection is required.

SYNOPSIS OF CONDITIONS OF SUPPLY

- (1) Water is provided only for the purpose for which the connection is requested (Appendix 1 Form 1A) and shall not be used for any other purpose without written permission of the Authority.
- (2) The Authority reserves the right in cases of non-compliance with its Conditions or Regulations to refuse to make a connection even though the relevant fee has been paid.
- (3) The Authority reserves the right in cases where a breach of its Conditions or Regulations has taken place to discontinue to supply the offending consumer.
- (4) The Authority reserves the right to meter any consumer and charge by volume. Current list of charges for supply by volume can be had at the Authority's offices.
- (5) The Authority reserves the right in cases where a breach of its Regulations or Condition of Contract is occurring to meter the offender and charge for the waste at a rate over and above the normal charge.
- (6) While endeavouring to provide a 24 hour supply, the Authority does not guarantee such a supply and cannot therefore be held responsible for any damage or loss resulting from failure to do so.
- (7) The Authority will be responsible for repairs and maintenance of the connection from the main up to and including the consumer's stopcock in cases where the stopcock is not located on private property. In cases where the stopcock is located on private property, the Authority will be responsible up to the boundary and in that case will not include the stopcock.

NOTE:

The above synopsis are a typical example of the type of conditions that might be used. The validity of these conditions depends to a large extent on the legal framework within which the Authority operates. Conditions that may be permissible under one legal system may not be so under another. This can be particularly true in regard to disconnecting an existing consumer for breach of Regulations. Therefore as stated before when drawing up Regulations or Conditions of Supply, particular care must be taken to see that they conform to the requirements of the existing legal framework.

Bye-Laws

Where bye-laws exist, clauses like the following may be more relevant:

- (1) The Authority reserves the right to take court action where breaches of its Regulations or Conditions which are enshrined in bye-laws are occurring. This may result in the offender being fined.
- (2) The Authority reserves the right, where a breach of its Conditions or Regulations is occurring to enter the offending consumer's premises and carry out any necessary remedial work at cost to the consumer.

For a further source of information on Bye-Laws, consult **Model Water Bye-Laws**, Ministry of Housing and Local Government (1966) London, H.M.S.O.

Appendix 2

Government of Bahrain
Ministry of Works, Power and Water
Water Supply Directorate
Regulations and Guide
for the
Installation of Water Services

ARRANGEMENT OF SECTIONS

Page

INTERPRETATION

11 -- 12

1. Definitions
2. Compliance with Standards
3. Approved Equivalent Standard

APPLICATION OF REGULATIONS

12 -- 13

4. Application of Regulations, Generally
5. Inspection of Installations and Connection with Supply
6. Approval of Water Fittings and Contractors
7. Fittings Lawfully Fitted
8. Closed Circuits
9. Fittings for Industrial and Research Purposes

GENERAL PROVISIONS

13 -- 14

10. Quality of Water Fittings
11. Method of Installation
12. Unserviceable Fittings and Fittings not mentioned in the Regulations
13. Deterioration through Electrolytic Action
14. Connections that would cause Contamination of Watermains
15. Taps for Drinking Water
16. Protection of Pipes, Fittings and Apparatus from Damage
17. Accessibility of Fittings
18. Disconnection of Disused Pipes

PIPES AND PUMP INSTALLATIONS

14 -- 17

19. Support of Pipes
20. Depth of Pipes Laid in the Ground
21. Protection of Pipes from Corrosion and Contact with Contaminating Substances
22. Water Fittings, or Pipes below ground, to be Resistant to or immune to Dezincification
23. Materials for Consumers Pipes
24. Pipes of other Materials
25. Materials of Pipes Conveying Hot Water
26. Pipes of Copper
27. Pipes of Cast Iron, Spun Iron or Asbestos Cement
28. Pipes and Fittings of Steel
29. Pipes of Polythene
30. Pipes of Unplasticised Polyvinyl Chloride
31. Temporary Supplies and Building Supplies
32. Bends or Curves in Pipes
33. Separate Service Pipes
34. Points of Entry of Service Pipes

TAPS AND VALVES

17 -- 18

35. Stopvalves on Pipes Supplying Buildings
36. Fire Hose Reels in Building
37. Drinking Water Fittings

38. Use of Water Softening Apparatus
39. Non Concussive Self Closing Cocks (Including Standpipes)
40. Mixing and Special Cocks
41. Stopvalves on Outlet Pipes from Storage Cisterns
42. Location of Draining Taps
43. Drinking Troughs
44. Draw-Off Taps
45. Stopvalves
46. Operation of Stopvalves
47. Ballvalves

STORAGE CISTERNS

18 – 19

48. Placing of Storage Cisterns
49. Support and Coverage of Storage Cisterns
50. Avoidance of Flooding: Buried or Sunken Cisterns Prohibited
51. Materials for Storage Cisterns
52. Standards for Storage Cisterns
53. Capacity of Storage Cisterns
54. Storage Cisterns to be Fitted with Ballvalves
55. Warning Pipes on Storage Cisterns
56. Gate, Diaphragm or Sluice Valve on Outlet Pipes

HOT WATER APPARATUS

20

57. Distance between Hot Water Apparatus and Draw-Off Taps
58. Position of Outlets in Relation to Level of Water in Cylinders and Tanks
59. Ballvalves on Hot Water Cisterns
60. Outlets from Feed Cisterns to Hot Water Apparatus
61. Hot Water Apparatus not to be Connected Directly to Service Pipe
62. Combination Cocks and Mixing Valves
63. Material for Hot Water Pipes
64. Materials for, and Support of Hot Water Cylinders and Tanks
65. Standards for Hot Water Cylinders and Tanks
66. Capacity of Hot Water Storage Cisterns, Cylinders and Tanks
67. Hot Water Apparatus – Provision for Expansion

BATHS, WASH BASINS AND SINKS

21

68. Inlets and Outlets of Baths etc.
69. Position of Taps on Baths etc.
70. Use of Hose or Moveable Pipe

FLUSHING CISTERNS

21 – 22

71. Provision of Flushing Cisterns
72. Ballvalves on Flushing Cisterns
73. Pipes Discharging to Water Closet Pans
74. Design and Arrangement of Flushing Cisterns for Water Closets
75. Design and Arrangement of Flushing Cisterns for Urinals
76. Water Closet Pans
77. Operation of Automatic Flushing Cisterns

- 78. Notices to Other Ministries
- 79. Application for Water Supply
- 80. Laying on of New Supplies
- 81. Repairs to Service Pipes
- 82. Supply of Water for Non-Domestic Use
- 83. Supply of Water by Measurement
- 84. Penalties

APPENDIX 2.1

24

List of British Standards referred to in the Regulations

APPENDIX 2.2

25

Sketches showing typical details of water supply installations

REGULATIONS

INTERPRETATION

1. DEFINITIONS

In these regulations, the following words and expressions shall have the meanings herein defined:

- 1.1 **"Approval"** or **"Approved"** means approval in writing by the Water Supply Directorate.
- 1.2 **"Ballvalve"** means any float operated valve for controlling the inflow of water to a cistern or vessel.
- 1.3 **"British Standard"** or **"B.S."**, **"British Standard Code of Practice"** means the current standard specification, or code of practice, with any amendments, a copy of which is available for inspection at the office of the Manager of Water Services of the Water Supply Directorate.
- 1.4 **"Building"** means any structure, whether of a permanent character or not, and whether movable or immovable.
- 1.5 **"Capacity"** in relation to any cistern means the capacity of the cistern measured up to the highest level the water can reach when the ball valve or other device for controlling the inflow of water is fitted and adjusted in the manner required by these regulations.
- 1.6 **"Cistern"** means a fixed container for water in which the water is at atmospheric pressure.
- 1.7 **"Closed circuit"** means any system of pipes and water fittings through which water circulates and from which water is not drawn for use, and includes any vent pipe fitted thereto, but not the feed cistern or the cold feed pipe.
- 1.8 **"Consumer"** means any corporate body, person, or persons supplied with, or applying to be supplied with water by the Water Supply Directorate. These Regulations also apply to consumers who are supplied from private sources. In such cases the regulations will be issued and enforced by the Municipality concerned.
- 1.9 **"Corrosion-resisting material"** means any material which is highly resistant to any corrosive action to which it is likely to be subjected in the circumstances in which it is used.
- 1.10 **"Cylinder"** means any cylindrical closed vessel capable of containing water under pressure greater than atmospheric pressure.
- 1.11 **"Distributing pipe"** means any pipe (other than an overflow pipe or a flushing pipe) conveying water from a storage cistern or from a hot water apparatus supplied from a feed cistern, or under pressure from that cistern.
- 1.12 **"Feed cistern"** means any storage cistern used for supplying cold water to a hot water apparatus, cylinder or tank.
- 1.13 **"Flushing cistern"** means a cistern having an efficient flushing apparatus of the valveless syphonic type for flushing a water closet pan, urinal or drain.
- 1.14 **"Overflowing level"** in relation to a warning or other overflow pipe of a cistern, means the lowest level at which water can flow into that pipe from that cistern.
- 1.15 **"Premises"** means any separately occupied house or building or part of a house or building and the curtilage thereof in respect of which water is supplied or applied for.
- 1.16 **"Service pipe"** means so much of any pipe for supplying water from a main to any premises as is subject to water pressure from that main.
- 1.17 **"Stopvalve"** means any device (including a stopcock and stop valve), other than a draw-off tap, for stopping the flow of water in a pipe.
- 1.18 **"Storage cistern"** means any cistern, other than a flushing cistern, having a free water surface under atmospheric pressure, but does not include a drinking trough or drinking bowl for animals, including poultry.
- 1.19 **"Tank"** means a non cylindrical closed vessel capable of containing water under pressure greater than atmospheric pressure.
- 1.20 **"Warning pipe"** means an overflow pipe so fixed that its outlet, whether inside or outside a building, is in a conspicuous position where the discharge of any water therefrom can readily be seen.
- 1.21 **"Water fittings"** includes pipes (other than mains), taps, cocks, valves, ferrules, meters, cisterns, baths, waterclosets and other similar apparatus used in connection with the supply and use of water.

2. COMPLIANCE WITH STANDARDS

- 2.1 Any requirements in these regulations that a water fitting shall comply with a British Standard shall be understood to mean that the fitting must comply with the standard only in relation to the size, nature, materials, strength and workmanship of that fitting.
- 2.2 Where any requirements of any such Standard relating to any of those matters conflicts with a specific requirement of these Regulations, the latter requirement shall prevail.
- 2.3 Should any consumer wish to use any water fitting, that complies with some other National or International Standard, full details of the fitting proposed for use shall be submitted in writing to the Water Supply Directorate together with authenticated English translations of any such proposed standard.

3. APPROVED EQUIVALENT STANDARD

- 3.1 The substitution of any such standard for a British Standard Specification (B.S.) or Code of Practice shall only be made with the approval of the Water Supply Directorate, and shall be recorded for the purposes of these Regulations as an "approved equivalent standard".

APPLICATION OF REGULATIONS

4. APPLICATION OF REGULATIONS, GENERALLY

- 4.1 No one shall:
 - (a) Use a water fitting for the purpose of conveying or receiving water supplied by the Water Supply Directorate or from any private source in contravention of a provision of these Regulations
or
 - (b) Connect a water fitting in contravention of or in a manner not in accordance with these Regulations
or
 - (c) Alter a water fitting so that it contravenes or is not in accordance with any of these Regulations
or
 - (d) Disconnect a water fitting, if as a result of the disconnection any of these Regulations are contravened.

5. INSPECTION OF INSTALLATIONS AND CONNECTION WITH SUPPLY

- 5.1 Before the laying on of a new water supply from any watermain of the Water Supply Directorate, or from a private supply, or before a connection for a supply of water can be made for domestic or non domestic use with an existing service pipe, the installation to be supplied shall be inspected and approved by an authorised officer of the Water Supply Directorate.
- 5.2 In this regard, applicants should seek the assistance of the Water Supply Directorate on the details before proceeding with an installation, to avoid non approval of the completed installation.
- 5.3 All such water fittings and the plumbing work connected therewith which are subsequently to be concealed or buried underground shall be left uncovered for inspection. Adequate notice shall be given at the offices of the Directorate when the installation is complete.

6. APPROVAL OF WATER FITTINGS AND CONTRACTORS

- 6.1 For the purpose of ensuring that water fittings comply with these regulations, representatives or agents of manufacturers shall apply in writing and if requested submit standard samples of pipes, fittings, apparatus etc., for examination to the Water Supply Directorate. The representative or agent shall be notified of the Directorate's decision in the matter.
- 6.2 All contractors engaged in the installation of water services must hold Government of Bahrain Contractors' licence, such licences being issued on payment of a fee to a suitably qualified applicant able to produce evidence of adequate stocks of materials for carrying out water supply installations within the capabilities of his staff, together with any testing apparatus specified by the Water Supply Directorate.
- 6.3 All licences issued will be valid for one year from date of issue after which time they will be considered lapsed unless a written application for renewal is received at least one month before the expiry date.

7. FITTINGS LAWFULLY FITTED

- 7.1 None of these Regulations, except those relating to unserviceable fittings and stop-valves, or services to buildings shall require any person to cease to use, disconnect, alter, dismantle or renew any water fittings lawfully used before these Regulations first applied provided that the continued use of these fittings does not cause waste, undue consumption, misuse, erroneous measurement or contamination of water.
- 7.2 Where any such fitting has the above effect, any remedial work necessary to make good the defects shall be carried out in accordance with the provisions of these Regulations. Compliance therewith may be postponed for such time as is reasonably required for carrying out the work.

8. CLOSED CIRCUITS

- 8.1 In relation to closed circuits those Regulations only shall apply which refer to the quality of water fittings, the method of installation, serviceability, protection of fittings, accessibility, draining taps on installations and penalties for non compliance with the Regulations.

9. FITTINGS FOR INDUSTRIAL AND RESEARCH PURPOSES

- 9.1 Where water is required for industrial or research purposes it shall be supplied through a meter to a cistern in accordance with the provisions of these Regulations. Where it is not practicable to apply these Regulations to water fittings supplied from the cistern, the Regulations shall apply only in respect of serviceability of the fittings and avoidance of any connections that could cause contamination to the water supply.

GENERAL PROVISIONS

10. QUALITY OF WATER FITTINGS

- 10.1 A person shall not, for conveying, delivering, receiving or using water supplied by the Water Supply Directorate or from any private source, fix, fit, or use any pipe, fitting or apparatus which shall not be of good quality and shall not be in accordance with the requirements of these Regulations.
- 10.2 A person shall not be required by this regulation to alter or renew any pipe, fitting or apparatus lawfully existing and lawfully in use at the date when this regulation first applied, unless such pipe, fitting or apparatus is so defective or restricted or in such condition as to cause or be likely to cause waste, undue consumption, misuse or contamination of the water supply.
- 10.3 A person shall not be prohibited from fixing, fitting, or using for such lawful purposes any approved pipe, fitting or apparatus constructed of material the strength, efficiency and durability of which does not fall below that of the material specified in these Regulations.

11. METHOD OF INSTALLATION

- 11.1 The method of installation of all pipes, fittings or apparatus shall be such that the creating of a negative pressure of air in the pipes shall be avoided, that the pipes, fittings and apparatus shall be free from backflowing and back-syphonage at all times, and that waste, undue consumption, misuse or contamination of the water supply shall be prevented.

12. UNSERVICEABLE FITTINGS AND FITTINGS NOT MENTIONED IN THE REGULATIONS

- 12.1 Any pipe, pipe fitting, draw-off, draining tap, stopvalve, ballvalve, float, cistern, cylinder, tank or flushing apparatus or any bath, washbasin, sink soil pan or similar appliance which is damaged, worn or unserviceable shall not be used.
- 12.2 Any other type of fitting, whether damaged, worn or unserviceable or not, shall not be used if it causes or is likely to cause waste, undue consumption, misuse or contamination of the water supply or reverberation in the pipes.

13. DETERIORATION THROUGH ELECTROLYTIC ACTION

13.1 Water fittings of dissimilar metals should not be used for the purpose of conveying or receiving the same water, unless:

- (a) the circumstances are such that deterioration of any of the fittings through electrolytic action is not likely to occur, or
- (b) effective measures are taken to prevent such deterioration.

14. CONNECTIONS THAT WOULD CAUSE CONTAMINATION OF WATER MAINS

14.1 No pipe or cistern used for carrying or receiving water supplied by the Water Supply Directorate shall convey or receive water not supplied by the Directorate.

14.2 The connection from a service pipe to any cistern shall discharge freely into the cistern at least 150mm above the highest possible water level in that cistern.

14.3 No pipe or cistern used for conveying or receiving potable water shall convey or receive non potable water.

15. TAPS FOR DRINKING WATER

15.1 In any premises in which water is supplied by the Water Supply Directorate, or from a private source, for domestic purposes, the consumer shall normally provide a draw-off tap on a service pipe in a position convenient for the drawing of drinking water.

15.2 The normal location for the draw-off tap for drinking water shall be over the kitchen sink, and a valve shall be located on the service pipe on the storage cistern side of the branch to the draw-off tap for drinking water.

15.3 In exceptional cases, where by reason of the height at which water is required to be delivered or because of some other circumstances, it is not reasonably practicable to provide in the premises a service pipe the tap may be provided on a pump delivery pipe or distributing pipe drawing water exclusively from a storage cistern which:

- (a) is a closed vessel, having a tightly fitting access cover bolted or screwed in position
- (b) is properly maintained and where necessary, suitably lined or coated to protect the potability of the water
- (c) has an air inlet and overflow pipe or pipes all suitably screened
- (d) is, where possible, insulated against heat

15.4 This Regulation shall not oblige anyone to install a tap for drinking water who had not such a tap installed before these Regulations applied.

16. PROTECTION OF PIPES, FITTINGS AND APPARATUS FROM DAMAGE

16.1 Each water fitting, whether inside or outside a building which is so placed as to be liable to damage shall be effectively protected from such damage.

17. ACCESSIBILITY OF FITTINGS

17.1 All pipes and fittings shall be arranged so as to be readily accessible and, where enclosed, the casing or duct shall be so constructed as to afford ready means of access to the pipes and fittings for examination, repair, replacement and operation. The point of discharge of any pipe or cock shall be in a position readily accessible for inspection.

18. DISCONNECTION OF DISUSED PIPES

18.1 If a person, supplied with water by the Water Supply Directorate wishes for any reason to have his supply disconnected, or if his supply has not been used and is not likely to be used in the future, he should apply for a disconnection to the Water Supply Directorate. This Regulation applies in particular to consumers who wish to demolish a building to which a supply was laid. Such consumers should, prior to the commencement of demolition work, apply to the Water Supply Directorate to have the supply disconnected to prevent damage, waste or contamination of the water supply.

PIPES AND PUMP INSTALLATIONS

19. SUPPORT OF PIPES

19.1 Every pipe shall be properly and adequately supported and shall be laid and fixed so as to avoid sagging, the development of air locks or reverberation.

20. DEPTH OF PIPES LAID IN THE GROUND

20.1 Every service pipe laid in the ground shall, unless it is under a building of a permanent character, at no time be less than 500mm nor more than 1350mm below the surface of the ground, measured from the top of the pipe to the ground surface, and when passing through the foundations of a building, the service pipe shall be fitted in a sleeve installed during the construction of the building.

21. PROTECTION OF PIPES FROM CORROSION AND CONTACT WITH CONTAMINATING SUBSTANCES

21.1 No pipe or pipe fitting shall be laid, installed in or on the ground unless it is either of a corrosion resisting material or effectively protected from external corrosion.

21.2 No service or distributing pipe shall be laid or fixed so as to pass into or through any sewer or drain, or any manhole connected therewith, or into or through any manure hole, cesspool, septic tank, or refuse pit.

21.3 No pipe shall be laid, installed in or on any foul soil or other substance which could cause contamination of the water in the pipe or deterioration of the pipe material.

21.4 No pipe made of any material susceptible to permeation by any gas or other substance which could cause contamination of the water in the pipe shall be laid, installed or allowed to remain in a position where such permeation could reasonably be expected to occur.

22. WATER FITTINGS, OR PIPES BELOW GROUND, TO BE RESISTANT TO OR IMMUNE TO DEZINCIFICATION

22.1 Every water fitting and every component of a water fittings or any pipe below ground which may be in contact with water shall be resistant or immune to dezincification.

23. MATERIALS FOR CONSUMERS PIPES

23.1 Every service pipe, distributing pipe, pump delivery pipe shall be of copper, stainless steel, galvanised mild steel, (G.B.) cast iron, spun iron, ductile iron, asbestos cement, polythene or unplasticised polyvinyl chloride and shall not be less than 13mm in nominal internal diameter throughout.

24. PIPES OF OTHER MATERIALS

24.1 Every service pipe, pump delivery pipe, distributing pipe and pipe fitting not being of a material specifically mentioned in Regulation 23 shall be of corrosion resisting material the nature, thickness and strength of which is suitable for the purposes for which it is to be used and shall be approved by the Water Supply Directorate.

25. MATERIALS OF PIPES CONVEYING HOT WATER

25.1 Every pipe used for conveying hot water shall be of copper, stainless steel, galvanised mild steel (G.B.) or some other corrosion

resisting material which is not less suitable and shall be approved by the Water Supply Directorate.

26. PIPES OF COPPER

26.1 Every service pipe, pump delivery pipe and distributing pipe of copper or copper alloy using screw joints or capillary or compression fittings, shall comply where relevant with B.S. 2871, 61, 66, 99, 864, and 1724 or equivalent approved standard.

27. PIPES OF CAST IRON, SPUN IRON OR ASBESTOS CEMENT

27.1 Every service pipe and every distributing pipe of cast iron, spun iron or asbestos cement shall comply in all respects with B.S. 78, 1211, 2035, 4622, 4722 or 486 or approved equivalent.

28. PIPES AND FITTINGS OF STEEL

28.1 Every service pipe or pump delivery pipe of steel and every distributing pipe of steel shall comply with the requirements for heavy tubes in B.S. 1387 or approved equivalent standard in respect of the conditions in which the pipe is to be used.

28.2 Every malleable cast iron pipe fitting connected to any steel service pipe, pump delivery pipe or distributing pipe shall comply with the relevant requirements of B.S. 143 and 1256 and every cast iron pipe fitting shall comply with the relevant requirements of British Standard 1641, 143 and 1256 or equivalent approved standard.

28.3 Every pipe fitting of wrought iron connected to any steel pipe being a service pipe, a pump delivery pipe or a distributing pipe shall comply with the relevant requirements of B.S. 1740 or equivalent approved standard.

29. PIPES OF POLYTHENE

29.1 Every pipe of polythene shall comply with B.S. 1972 or 3284 or approved equivalent standard and shall only be used for the supply or discharge of cold water where there is no possibility whatever of the pipe becoming charged with hot water and where the maximum pressure to which the pipe will be liable to be subjected under working conditions does not exceed that set down in the relevant standard on dimensions. Tables 1 apply.

29.2 Every service pipe, pump delivery pipe, distributing pipe, or warning pipe of polythene shall be jointed by means of approved

joints. Screwed, butt-welded, spigot joints or joints which require a manipulation of the pipe to accommodate any insert of a larger diameter than the internal diameter of the pipe are not approved.

30. PIPES OF UNPLASTICISED POLYVINYL CHLORIDE

30.1 Every pipe of unplasticised polyvinyl chloride, hereinafter referred to as UPVC shall comply with British Standard 3505 : 1968 "Unplasticised PVC pipe for cold water services" and shall only be used for the supply or discharge of cold water where there is no possibility whatever of the pipe becoming charged with hot water or discharging hot water. Pipes shall conform to Tables 1 and 1A of BS 3505 as applicable.

30.2 Every service pipe, pump delivery and distributing pipe of UPVC shall be jointed by means of joints approved by the Water Supply Directorate.

31. TEMPORARY SUPPLIES AND BUILDING SUPPLIES

31.1 Any service pipe or distributing pipe installed to provide a temporary supply of water to a building during its erection or for other approved purposes shall not be used for the permanent supply to a premises without the written approval of the Water Supply Directorate, who must be asked in writing for approval.

31.2 Where such a temporary supply is allowed for building purposes, a standpipe with cock shall be provided and all exposed pipe shall be securely fixed to a stout wooden post of minimum height of 1.5m and if the Water Supply Directorate considers it necessary, the cock shall be enclosed in a strong box of wood or other suitable material complete with a safe lock and key. Provision shall be made for the installation of a meter if required.

31.3 Where a temporary supply for building purposes is installed, it shall be laid in such a position that it may be used for the permanent supply on completion of the building.

32. BENDS OR CURVES IN PIPES

32.1 No bend or curve in any pipe shall be made so as materially to diminish or alter the internal diameter or strength of the pipe in any part.

33. SEPARATE SERVICE PIPES

33.1 Every premises supplied with water by the Water Supply Directorate or from a private source shall be supplied by a separate service pipe, which shall not communicate with or supply water to any other premises. The service pipe to each premises shall lie wholly within the curtilage of that premises.

33.2 In a building divided into self-contained flats or other separate units, any such flat or unit shall be supplied by a 13mm nominal internal diameter sub-service pipe controlled by a stopcock and branched within or without the building, from a common service pipe of an internal diameter to be determined by the Water Supply Directorate in each case, but not less than 19mm in normal internal diameter.

33.3 In a building that is divided into self-contained flats or other separately chargeable units, and which is of such elevation that individual service pipes cannot provide adequate pressure to each unit, the owner of the building shall be allowed a common service pipe to a break pressure tank located at ground level. Such a break pressure tank shall be a closed vessel with a tightly fitting access cover bolted or screwed in position, and shall have all overflow and air inlet opening suitably screened. The tank shall be suitably lined or coated to protect the potability of the water and shall be insulated against heat, and adequate access for cleaning and maintenance shall be provided. Pumping from such tank shall be to a pressure system, from which one draw off shall be permitted for each flat or chargeable unit. Each such draw off shall comply with the requirements for service pipes in regulation 34 of these regulations. Each flat or chargeable unit shall have a separate cold water cistern.

33.4 In exceptional circumstances the Water Supply Directorate may approve of the following alternative to a pressure system:

The pump shall deliver water from the break pressure tank through a communal rising main to a common high level storage tank. From this tank separate supply pipes shall be provided for each consumer. Each such supply pipe shall comply with the requirements for service pipes in regulation 34 of these Regulations.

33.5 All pumps shall be fitted with approved automatic controls which will effectively ensure that water is not pumped to waste, and shall start and stop pumps at designed pressure or capacity conditions.

- 33.6 The maintenance of all break pressure tanks, pumps and ancillaries, rising mains and common high level tanks shall be the responsibility of the consumer connected thereto.
- 33.7 Full details of all such installations must be submitted to the Water Supply Directorate for approval.

34. POINTS OF ENTRY OF SERVICE PIPES

- 34.1 Every service pipe shall, so far as is practicable be so laid as to follow the most suitable route between the Water Supply Directorate's main or private supply main and the consumer's premises. A meter and non-return stop valve shall be installed inside the curtilage of the consumers property either on the side of the external wall at the doorway or inside the house, flat or other separately chargeable unit, in the entrance hall near the front door or other suitable location. The particular location of the valve and meter to be approved by the Water Supply Directorate.

TAPS AND VALVES

35. STOPVALVES ON PIPES SUPPLYING BUILDINGS

- 35.1 Every pipe supplying water to a building shall be fitted with a non-return stop valve inside and as near as is reasonably practicable to the point where it enters that building.
- 35.2 Every pipe supplying water to a part of a building which is separately chargeable shall be fitted with a non-return stop valve, inside and as near as is reasonable practicable to the point where it enters that part of the building.
- 35.3 The layout of supply pipes and the location of stop valves and meters, where required, in a building or buildings to which multiple chargeabilities apply must be approved by the Water Supply Directorate.

36. FIRE HOSE REELS IN BUILDING

- 36.1 No fire hose reel intended to be supplied with water from the Water Supply Directorate mains or from a private source shall be installed until the design of the installation has been approved by the Water Supply Directorate and the Chief Fire Officer of the Ministry of the Interior. Where approval is given, the reels shall be supplied by pipes of not less than 38mm internal diameter.

Each reel shall be controlled by a suitable gate valve having a hand wheel, fitted as near as practicable to the reel.

- 36.2 No service pipe, pump delivery pipe or distributing pipe of thermoplastic materials shall be used above ground for fire hose reel installations.

37. DRINKING WATER FITTINGS

- 37.1 Where, in any premises, water is provided for drinking purposes, the consumer shall fix, over a household sink or in some other approved position, a draw-off cock or approved drinking fountain connected with the service pipe.
- 37.2 The location of all such cocks and fountains shall be subject to the approval of the Water Supply Directorate.

38. USE OF WATER SOFTENING APPARATUS

- 38.1 No person shall install any apparatus for softening water except in pursuance of an agreement in writing with the Water Supply Directorate. Where the use of such apparatus is permitted, consumers must ensure that the apparatus is correctly installed and the pipes, fittings and apparatus are suitable for the reception of the softened water.

39. NON-CONCUSSIVE SELF-CLOSING COCKS; (Including Standpipes)

- 39.1 The Water Supply Directorate reserves the right to insist on fixing of non-concussive self-closing cocks in all premises.
- 39.2 No person shall erect or set up, a standpipe which is accessible to the occupants of more than one dwelling for conveying water supplied by the Water Supply Directorate or from a private source unless the pipe is provided with a non-concussive self-closing tap.

40. MIXING AND SPECIAL COCKS

- 40.1 Single outlet combination cocks, mixing valves for hot and cold water and all other cocks which are not the ordinary screw-down type shall be so constructed and of such strength as to be adequate for preventing waste, undue consumption or contamination of water, and shall be approved. All such fittings shall be supplied only from storage or feed cisterns.
- 40.2 This Regulation shall not prohibit the fixing over a household sink of an approved double outlet combination cock for drawing drinking water if the streams of cold water and hot water are kept separate and do not mix

until they emerge from the nozzle of the cock.

41. STOPVALVES ON OUTLET PIPES FROM STORAGE CISTERNS

41.1 Every draw-off pipe from every cold water storage cistern of a capacity exceeding 18 litres shall be fitted with a stopvalve as near to the cistern as is reasonably practicable, and in a convenient and accessible position. Where such a draw-off pipe is connected directly to a hot water storage cistern, cylinder or tank in such a way that it is not reasonably practicable to fit a stopvalve on that pipe a stopvalve shall be fitted on every draw-off pipe from the hot water cistern, cylinder or tank, as near thereto as is reasonably practicable, and shall be accessible.

42. LOCATION OF DRAINING TAPS

42.1 No draining tap shall be buried in the ground. No draining tap shall be so placed that its outlet is in danger of being flooded.

43. DRINKING TROUGHS

43.1 Every pipe supplying water to a drinking-trough or drinking-bowl for animals, including poultry, shall be fitted with a ballvalve or some other not less effective device for controlling the inflow of water, so designed as to prevent overflow, or a draw-off and every such ballvalve, device, tap or stopvalve shall be effectively protected from damage, contamination and unauthorised interference.

43.2 No such trough or bowl shall be supplied directly from a service pipe, but should be supplied from a cistern which is controlled by a ballvalve.

44. DRAW-OFF TAPS

44.1 Every metal bodied or plastic bodied tap or draining tap shall comply with the relevant requirements of B.S. 5412, 5413, 1010, or 2879 or approved equivalent standard.

45. STOPVALVES

45.1 Every stopvalve whether used above or under the ground of any nominal size shall comply with the relevant requirements of B.S. 1010, 5433, or 5163 or approved equivalent standard.

46. OPERATION OF STOPVALVES

46.1 Every stopvalve shall be so placed that it can be readily operated.

47. BALLVALVES

47.1 Every pipe supplying water to any cistern shall be fitted with a ballvalve, or shall have some other approved not less effective device for controlling the inflow of water so designed to prevent outflow and constructed and positioned to effectively prevent back syphonage into the mains.

47.2 Every ballvalve of the piston or diaphragm type shall comply with B.S. 1212 or approved equivalent standard and shall not be less than 13mm nominal size.

47.3 Every ballvalve float of copper or plastic shall comply with B.S. 1968 and 2456 or approved equivalent standard.

47.4 Every ballvalve shall be securely and rigidly fixed to the cistern which it serves, and in such a position that it discharges freely at a level higher than the top of the overflow warning pipe, or, if there is more than one overflow pipe, — the highest overflow pipe, and so that the outlet or body of the ballvalve cannot become submerged.

47.5 In the case of every ballvalve fitted to a cistern, the size of the orifice, the size of the float and the length of the lever shall be such that, when the float is immersed to an extent not exceeding half its volume, the valve is water tight against the highest pressure at which it may be required to work.

STORAGE CISTERNS

48. PLACING OF STORAGE CISTERNS

48.1 Every storage cistern from which water is drawn for domestic purposes shall be so placed and equipped that its interior can be readily inspected and cleaned, and no cistern shall be placed and equipped so that the water in it is liable to contamination.

49. SUPPORT AND COVERAGE OF STORAGE CISTERNS

49.1 Every storage cistern shall be adequately supported, and if water for domestic purposes is drawn from it, shall be suitably covered but not so as to be air tight.

49.2 Every cover shall effectively exclude light and shall be rigid with overlapping edges so constructed that it cannot easily be dislodged and shall be of material which will not contaminate any condensate.

50. AVOIDANCE OF FLOODING: BURIED OR SUNKEN CISTERNS PROHIBITED

- 50.1 No storage cistern shall be buried or sunk in the ground otherwise than with the agreement in writing of the Water Supply Directorate.
- 50.2 No storage cistern shall be so placed that it is in danger of being flooded.

51. MATERIALS FOR STORAGE CISTERNS

- 51.1 Every storage cistern shall be watertight and of adequate strength and shall be constructed of galvanised iron or steel, copper, asbestos cement, concrete or some other not less suitable material which must be approved in writing by the Water Supply Directorate.
- 51.2 Where the cistern is not made of a corrosion-resisting material it shall be effectively protected from corrosion.

52. STANDARDS FOR STORAGE CISTERNS

- 52.1 Every storage cistern, whether constructed of mild steel, asbestos cement, cast iron or pressed steel plate, polythene or polypropylene shall comply with the relevant requirements of B.S. 417, 2777, 1563, 1564, and 4213 or other approved equivalent standards.

53. CAPACITY OF STORAGE CISTERNS

- 53.1 For the protection of the water supply and in the interest of the consumers, water which is used for the supply to any flushing apparatus or for the cold water supply to any bath, shower bath, wash basin or other fittings or apparatus or to any domestic system of hot water supply shall be drawn from cold water storage or feed cisterns.
- 53.2 Where two or more cisterns are coupled together to function as a single cistern, the outlet shall be located in the cistern furthest from the inlet.
- 53.3 Minimum water storage requirements are as follows:
- Individual houses or single flats – 100 litres/unit
 - Other premises, such as hotels, office blocks, institutions, industrial premises and blocks of flats – 1 day's requirements subject to approval of Water Supply Directorate.

54. STORAGE CISTERNS TO BE FITTED WITH BALLVALVES

- 54.1 Every pipe supplying water to a cold water

storage cistern shall be fitted with an approved ballvalve or shall have some other not less effective device for controlling the inflow of water so designed as to prevent overflow.

- 54.2 When two or more cold water storage cisterns at the same level or connected together, the pipes used to connect one cistern to another need not be fitted with ballvalves.

- 54.3 Every pipe supplying water to a cold water cistern, whether fitted with a ballvalve or not, other than a pipe used only to connect one cistern to another, shall be fitted in such a position that it discharges at a level higher than the overflowing level of the overflow pipe, or if there is more than one overflow pipe, the highest overflow pipe.

55. WARNING PIPES ON STORAGE CISTERNS

- 55.1 Every cold water storage cistern shall comply with the following requirements:

- it shall be fitted with an efficient warning pipe of a corrosion-resisting material and with no other overflow pipe if its capacity is less than 4.5 cu.m.
- if the capacity is in excess of 4.5 cu.m. warning pipe shall be located such that it indicates when the water reaches a level not less than 50mm. below the overflowing level of the overflow pipe or if there is more than one overflow pipe, the lowest one.
- no overflow pipe shall rise in level outside the cistern.
- in cisterns where both a warning pipe and some other overflow pipe or pipes are fitted, the internal diameter of the warning pipe shall not be less than 25mm.

56. GATE, DIAPHRAGM OR SLUICE VALVE ON OUTLET PIPES

- 56.1 On every outlet pipe, other than a warning pipe, from every storage or feed cistern of a capacity exceeding 18 litres, a suitable gate, diaphragm or sluice valve shall be provided in a convenient and accessible position, as near to the storage or feed cistern as practicable. An accessible gate or sluice valve shall also be provided on the inlet pipe from the storage or feed cistern to any group of fittings and as close as possible to those fittings which are supplied from that storage or feed cistern.

HOT WATER APPARATUS

57. DISTANCE BETWEEN HOT WATER APPARATUS AND DRAW-OFF TAPS

57.1 The length of any pipe conveying hot water from any hot water apparatus, hot water storage cistern, cylinder or tank, or flow and return system to any draw-off tap shall be as short as possible and shall be lagged.

58. POSITION OF OUTLETS IN RELATION TO LEVEL OF WATER IN CYLINDERS AND TANKS

58.1 No tap or other means of drawing water shall be connected to any part of a hot water system in such a position that its use can lower the level of water in the hot water storage cistern:

- (a) below the level of the top of any pipe connecting the cistern, cylinder or tank to the water heating apparatus or
- (b) below three-quarters of the depth of the cylinder or tank, or below half the depth of the cistern.

59. BALLVALVES ON HOT WATER CISTERNS

59.1 No hot water storage cistern shall be fitted with a ballvalve unless the ballvalve is of material for the purpose and complies in its construction and fitting with the requirements of these regulations on ballvalves for cold water storage cisterns.

60. OUTLETS FROM FEED CISTERNS TO HOT WATER APPARATUS

60.1 The outlet from a feed cistern to a hot water apparatus shall be at a distance of not less than 25mm above the bottom of the feed cistern and the feed pipe of suitable internal diameter shall deliver water to the hot water apparatus only.

61. HOT WATER APPARATUS NOT TO BE CONNECTED DIRECTLY TO SERVICE PIPE

61.1 Where any apparatus in which water is heated is supplied with cold water from a service pipe the pipe shall not be connected directly to the apparatus. It shall discharge freely into the air not less than 13mm above the top of the apparatus. This Regulation shall not apply if the water heater is of the instantaneous type or is not capable of holding more than 15 litres.

62. COMBINATION COCKS AND MIXING VALVES

62.1 Where combination cocks, mixing valves and

similar apparatus for mixing hot and cold water are installed in any premises, the hot water system and the cold water connection to the mixing apparatus shall be supplied from the same feed cistern or a separate cistern situated at the same level.

62.2 All such fittings shall be supplied by means of suitably sized pipes, whether direct from storage cisterns or branched from common distribution pipes which will ensure an adequate and constant discharge at all fittings.

63. MATERIAL FOR HOT WATER PIPES

63.1 Every pipe used for conveying hot water shall be of copper or some other corrosion-resisting material which is not less suitable.

64. MATERIALS FOR, AND SUPPORT OF HOT WATER CYLINDERS AND TANKS

64.1 Every hot water cylinder shall be constructed of copper, stainless steel, galvanised mild steel or of other materials approved by the Water Supply Directorate, and shall be adequately supported.

64.2 Where the hot water cylinder is not made of corrosion-resisting material, it shall be effectively protected from corrosion.

65. STANDARDS FOR HOT WATER CYLINDERS AND TANKS

65.1 Every hot water cylinder or tank shall comply with the relevant requirements of the following British Standards 1566, 843, 853 and 3198 or with an approved equivalent standard.

66. CAPACITY OF HOT WATER STORAGE CISTERNS, CYLINDERS AND TANKS

66.1 Every hot water storage cistern, cylinder or tank shall be capable of holding not less than 115 litres. Where the hot water system includes two or more hot water cylinders or tanks at different levels, this Regulation shall apply only to the lowest cylinder or tank.

67. HOT WATER APPARATUS – PROVISION FOR EXPANSION

67.1 In every hot water apparatus provision shall be made for the expansion of the water during heating to prevent the water running to waste. If the water is contained in a closed circuit under pressure the expansion of the water shall be by an expansion pipe of not less than 19mm in nominal internal diameter connected to the top of the cylinder. Every such pipe shall have a rise in every

part of its course. It shall be carried above the level of the water line of the feed cistern to a height of at least 0.5m and bent down over the cistern.

BATHS, WASH BASINS AND SINKS

68. INLETS AND OUTLETS OF BATHS ETC.

68.1 Every inlet to a bath, wash basin, sink or similar appliance shall be separate from and unconnected with any outlet from the appliance.

68.2 Every outlet for emptying a bath, wash basin, sink or similar appliance shall be provided with a well fitted and readily accessible watertight plug or with some other not less effective means of closing the outlet.

69. POSITION OF TAPS ON BATHS ETC.

69.1 Every draw-off tap or other fitting which discharges water into a bath, wash basin, sink or similar appliances shall be fitted in such a position that it cannot discharge at a level lower than 13mm above the lowest part of the top edge of the appliance.

70. USE OF HOSE OR MOVEABLE PIPE

70.1 A person shall not draw or use water through any hose or moveable pipe where water is not supplied through a meter which is used as a basis of charge, except by agreement with the Water Supply Directorate.

70.2 Every service pipe, pump delivery or distributing pipe supplying a hose or moveable pipe shall be fitted with an approved back-flow preventer.

70.3 Any use of water supplied by the Water Supply Directorate or from a private source for agricultural or garden watering purposes shall be by use of a method approved by the Water Supply Directorate, such as a drip watering system.

FLUSHING CISTERNS

71. PROVISION OF FLUSHING CISTERNS

71.1 Every water closet pan and urinal shall be provided with an approved flushing cistern separate and distinct from any cistern used to contain water for domestic or other purposes or with an approved flushing apparatus which is not less suitable in preventing waste, undue consumption or contamination of water.

71.2 Every flushing cistern provided in connection with a water closet pan or any urinal shall be so constructed, installed and maintained that the syphonic apparatus shall be capable of being easily and readily brought into action when the water is at the water line and that water cannot flow down the flush pipe except when a flush is being properly delivered.

72. BALLVALVES ON FLUSHING CISTERNS

72.1 The requirements of these Regulations in respect of ballvalves for cold water storage cisterns shall apply to ballvalves fitted to flushing cisterns.

73. PIPES DISCHARGING TO WATER CLOSET PANS

73.1 No pipe, other than a flushing pipe leading from a flushing cistern shall deliver water to any watercloset pan or urinal.

74. DESIGN AND ARRANGEMENT OF FLUSHING CISTERNS FOR WATER CLOSETS

74.1 Flushing cisterns shall comply with B.S. 1125 or approved equivalent standard and shall be of 9 litres discharge capacity, which means the quantity of water discharged when the cistern is filled to the water line with the ballvalve closed.

74.2 Every flushing cistern shall be clearly and indelibly marked with the name of the manufacturer, which should be seen without dismantling the article.

75. DESIGN AND ARRANGEMENT OF FLUSHING CISTERNS FOR URINALS

75.1 A flushing cistern or other flushing apparatus serving a urinal shall not give a flush of more than 4.5 litres and shall comply with B.S. 1876 or 1125 or approved equivalent standard.

75.2 Where a group of three urinals is flushed by one flushing cistern, the flush shall be of not more than 9 litres discharge capacity.

76. WATER CLOSET PANS

- 76.1 Every water closet pan of the washdown, syphonic, squat or any special type shall be constructed of vitreous china, fireclay, stainless steel or of other materials approved by the Water Supply Directorate.
- 76.2 Every water closet shall be so constructed that after normal use its contents will be effectively cleared by one flush from the flushing cistern or flushing apparatus to which it is connected.
- 76.3 Every water closet pan shall be clearly and indelibly marked with the name of the manufacturer, which should be readily seen.
- 76.4 When general approval is given for a particular manufacturer's flushing cistern or flushing apparatus and the water closet pan as a high level or as a low level suite, it shall be fixed in accordance with the manufacturers' instructions and any interference with or alteration of or substitution of other parts is prohibited.

77. OPERATION OF AUTOMATIC FLUSHING CISTERNS

- 77.1 No automatic flushing cistern serving a urinal shall flush the urinal automatically at intervals of less than twenty minutes.
- 77.2 Every automatic flushing cistern serving a urinal shall be fitted with a time switch or some other device for ensuring that the cistern will not operate during any periods when the premises are closed.

CONDITIONS OF SUPPLY

78. NOTICES TO OTHER MINISTRIES

- 78.1 All necessary approvals for any water supply installation work which involves work in public roads, should be obtained before the commencement of such work.
- 78.2 Any other Ministry requiring water services shall advise the Water Supply Directorate of its requirements as far in advance as is practicable.
- 78.3 Full details of such requirements and proposals shall be submitted to the Water Supply Directorate for approval.

79. APPLICATION FOR WATER SUPPLY

- 79.1 Any person requiring a new or additional water supply from the Water Supply Directorate should first contact the commercial unit of the Water and Electricity Directorates. Application should be made by completing the standard "Application for Supply of Water" form.

80. LAYING ON OF NEW SUPPLIES

- 80.1 Where the laying on of a new supply has been agreed by the Water Supply Directorate, the Directorate will lay the service pipe from the water main to the consumers stopcock for a standard connection fee. The consumer must provide and fit at his own expense, an approved type meter box, which shall be mounted as shown in Appendix 2.2, Sketch 3 of these regulations.

- 80.2 On Ministry of Housing and other sites where the builder, developer or Ministry makes a service connection to the estate distribution main, the standard connection fee will be payable by the householder.

- 80.3 In the case of premises located in areas not served by the existing distribution system, the Water Supply Directorate will not be obliged to provide connections. However, where feasible the WSD may provide a temporary connection and the applicant must pay the full cost of such a connection. When the network is extended to service such an area, a permanent connection will be provided at no extra charge to the applicant.

- 80.4 The Water Supply Directorate reserves the right to meter any supply at any time.

81. REPAIRS TO SERVICE PIPES

- 81.1 The Water Supply Directorate will maintain and repair the portion of any service pipe between the main and the point where the pipe enters private property.

82. SUPPLY OF WATER FOR NON-DOMESTIC USE

- 82.1 The Water Supply Directorate may by contract agree to supply water for non-domestic use subject to the following:
- the water shall be supplied through a service pipe to a storage cistern or cisterns, the capacity of which shall be approved by the Water Supply Directorate but shall not be less than the twenty four hour requirement.
 - To avoid the possibility of contamination

of the supply by back syphonage the water supplied by the Water Supply Directorate must discharge freely into the air not less than 150mm above the flood rim of the storage cistern.

- (c) The supply will be metered.
- (d) The consumer will construct a meter chamber to dimensions and of materials as shown on Appendix 2.2, sketch 2 of the Regulations or to other dimensions and materials which shall be not less suitable, and which will meet with the written approval of the Water Supply Directorate.

83. SUPPLY OF WATER BY MEASUREMENT

83.1 Any water supplied by the Water Supply Directorate may be charged for at rates approved from time to time.

84. PENALTIES

84.1 If any consumer is found in serious and continuous breach of these Regulations, the Water Supply Directorate reserves the right to disconnect the supply.

84.2 Any breach of these Regulations by a licensed contractor will entail the immediate cancellation of his Water Installation Licence. A cancelled licence may not be reinstated until the renewal application form has been completed and registration fees have been paid, and then only on written confirmation that the Regulation will be strictly observed.

APPENDIX 2.1

LIST OF BRITISH STANDARDS REFERRED TO IN THE REGULATIONS

- B.S. 61: "Threads for light gauge copper tubes and fittings"
B.S. 66: "Cast copper alloy pipe fittings for use with screwed copper tubes"
99:
B.S. 78: "Cast Iron Spigot and socket pipes (vertically cast) and spigot and socket fittings"
B.S. 143: "Malleable cast iron and cast copper alloy screwed pipe fittings for steam, air, water, gas and oil"
1256:
B.S. 417: "Galvanised mild steel cisterns and covers, tanks and cylinders"
B.S. 486: "Asbestos-cement pressure pipes"
B.S. 843: "Stationary non-instantaneous electric water heaters (constructional and water requirements)"
B.S. 853: "Calorifiers for central heating and hot water supply"
B.S. 864: "Capillary and compression tube fittings of copper and copper alloy"
B.S. 1010: "Draw-off taps and stopvalves for water services (screwdown pattern)"
B.S. 1125: "W.C. flushing cisterns"
B.S. 1211: "Centrifugally cast (spun) iron pressure pipes for water, gas and sewage"
B.S. 1212: "Ballvalves (excluding floats)"
B.S. 1387: "Steel tubes and tubulars suitable for screwing to B.S. 21 pipe threads"
B.S. 1563: "Cast Iron sectional rectangular tanks"
B.S. 1564: "Pressed steel sectional rectangular tanks"
B.S. 1566: "Copper indirect cylinders for domestic purposes"
B.S. 1641: "Cast iron pipe fittings (screwed BSP) for automatic sprinklers and other fire protection installations"
B.S. 1724: "Bronze welding by gas"
B.S. 1740: "Wrought steel pipe fittings (screwed BSP thread)"
B.S. 1876: "Automatic flushing cisterns for urinals"
B.S. 1968: "Floats for ballvalves (copper)"
B.S. 1972: "Polythene pipe (Type 32) for cold water services"
B.S. 2035: "Cast iron flanged pipes and flanged fittings"
B.S. 2456: "Floats (plastic) for ballvalves for hot and cold water"
B.S. 2777: "Asbestos-cement cisterns"
B.S. 2871: "Copper and copper alloys. Tubes"
B.S. 2879: "Draining taps (Screw down pattern)"
B.S. 3198: "Combination hot water storage units (copper) for domestic purposes"
B.S. 3284: "Polythene pipe (Type 50) for cold water services"
B.S. 3505: "Unplasticised PVC pipe for cold water services"
B.S. 4213: "Cold water storage cisterns (Polyolefin or olefin copolymer) and cistern covers"
B.S. 4622: "Grey iron pipes and fittings"
B.S. 4772: "Ductile iron pipes and fittings"
B.S. 5163: "Double flanged cast iron wedge gate valves for water works purposes"
B.S. 5412: "Specification for the performance of draw-off taps with metal bodies for water services"
B.S. 5413: "Specification for the performance of draw-off taps with plastic bodies for water services"
B.S. 5433: "Specification for underground stopvalves for water services"

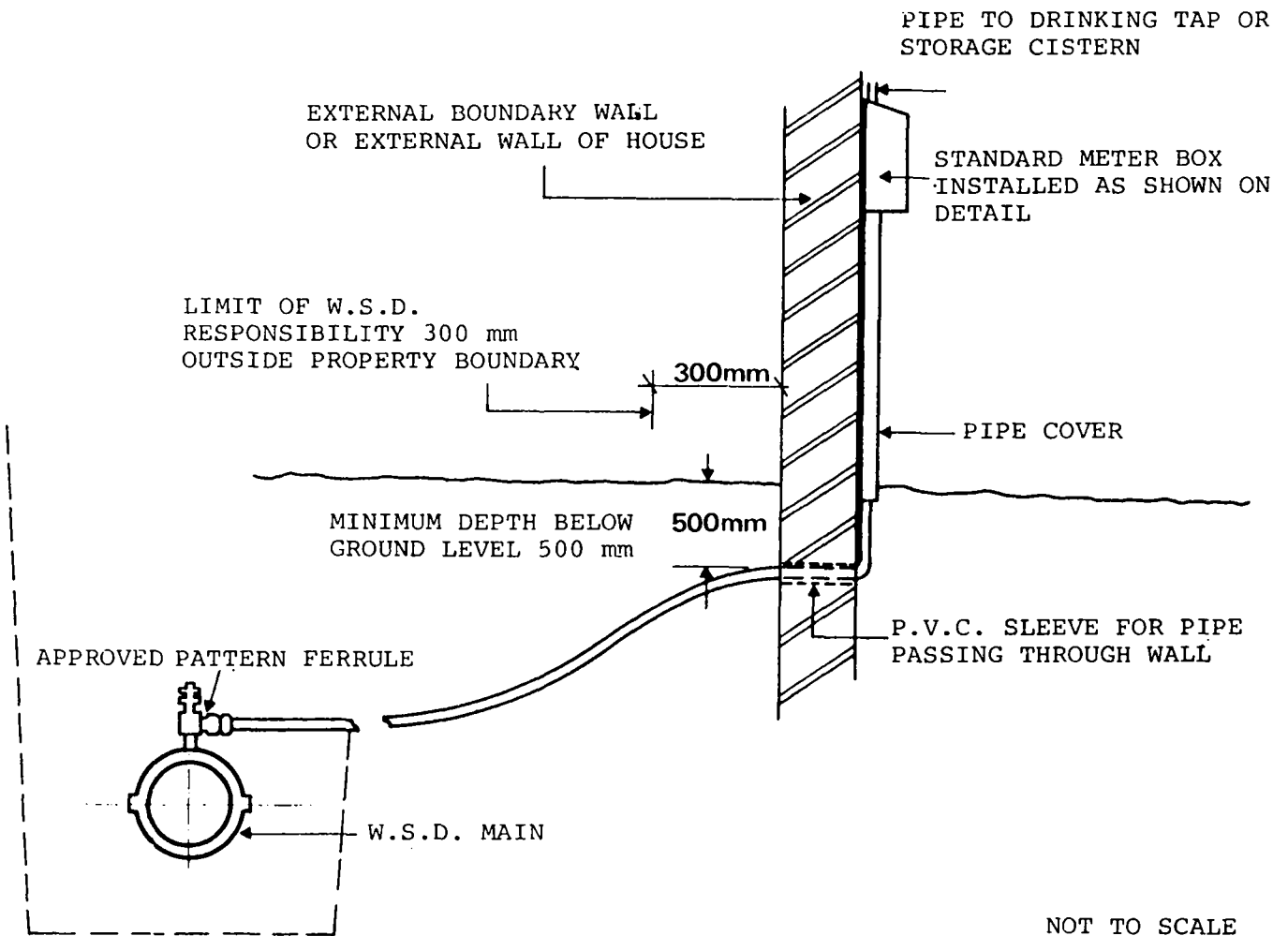

1. Single House Connection—Typical Detail

SKETCH 2

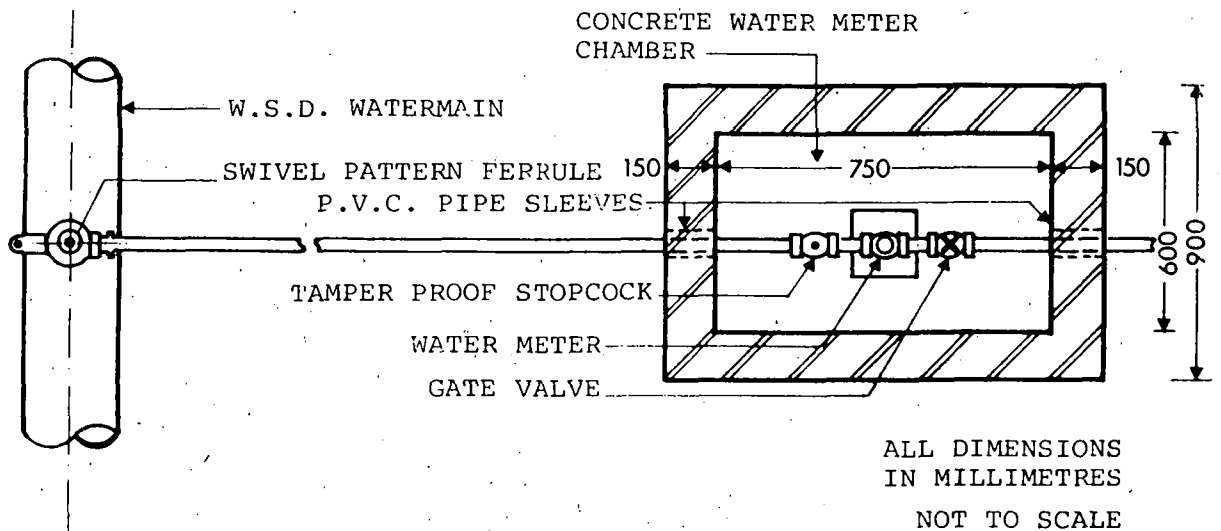
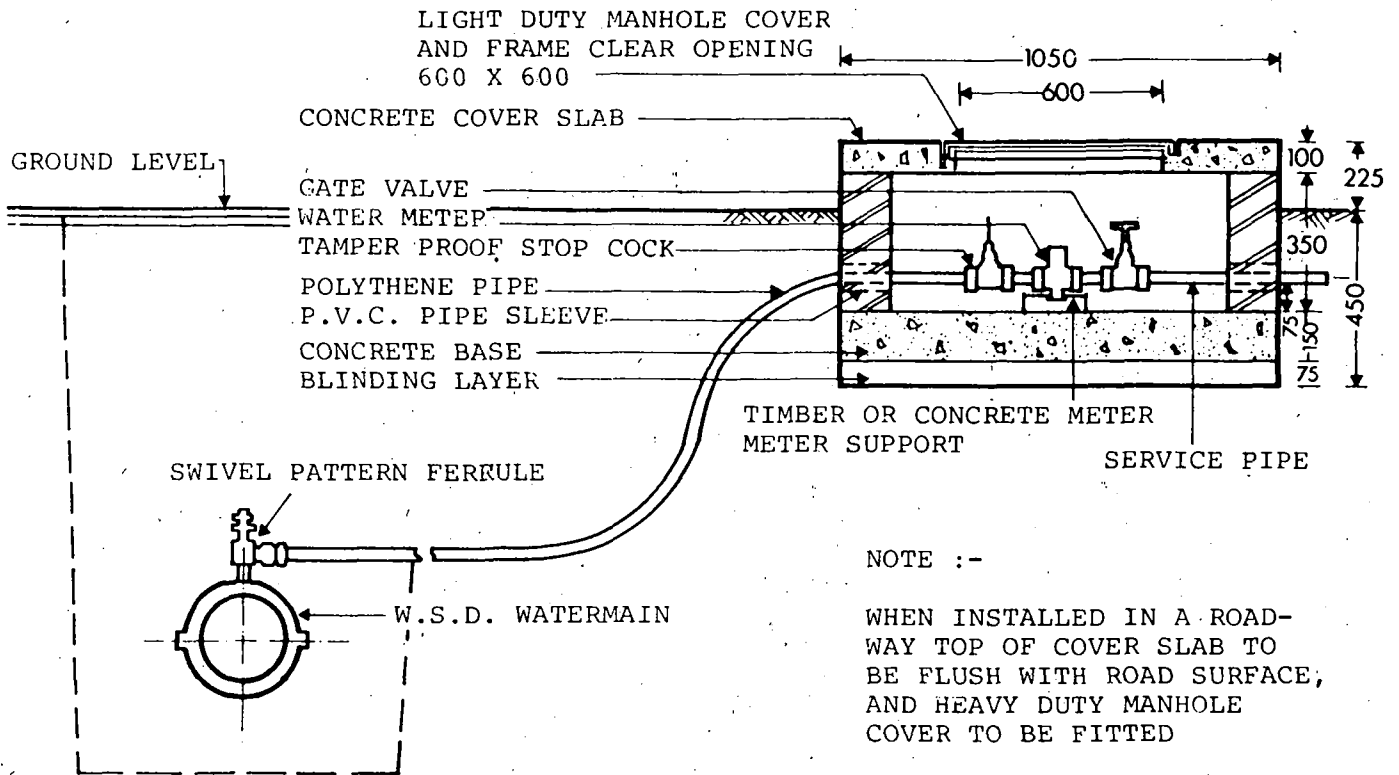

2. Bulk Meter Installation—Typical Detail

SKETCH 3

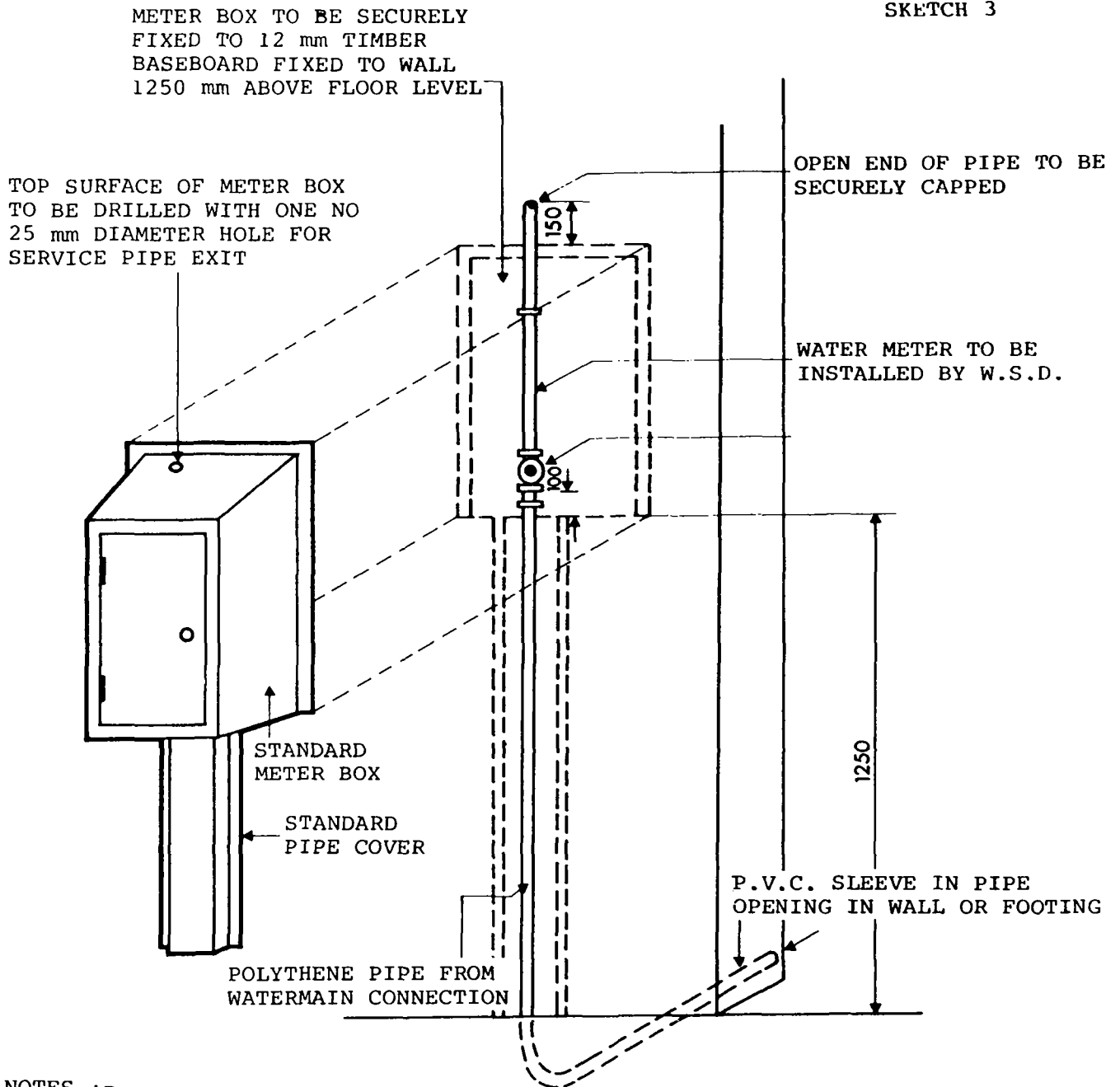

NOTES :-

METER BOX TO BE LOCATED
INSIDE THE CONSUMER'S
PROPERTY NEAR THE MAIN
ENTRANCE OR ON INSIDE OF
PERIMETER WALL,
PREFERABLY ADJACENT TO
ELECTRICITY METER

ALL PIPEWORK, PIPE FITTINGS
METER BOX, PIPE COVER AND
PIPE SLEEVE TO BE INSTALLED
BY THE CONTRACTOR

ALL DIMENSIONS
IN MILLIMETRES
NOT TO SCALE

3. Water Meter Box Installation Detail

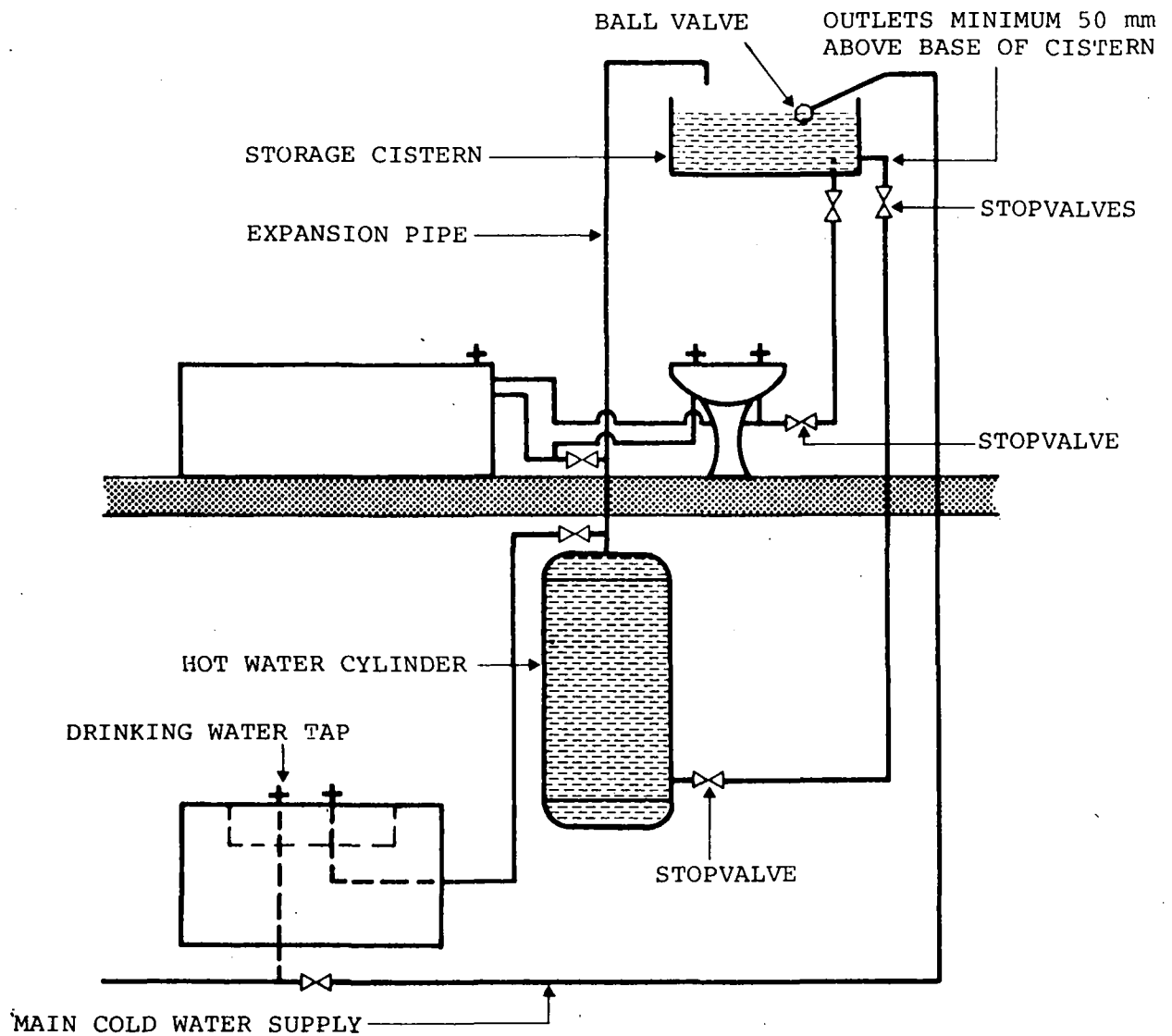

NOT TO SCALE

4. Domestic Hot Water Apparatus Single House – Typical Detail

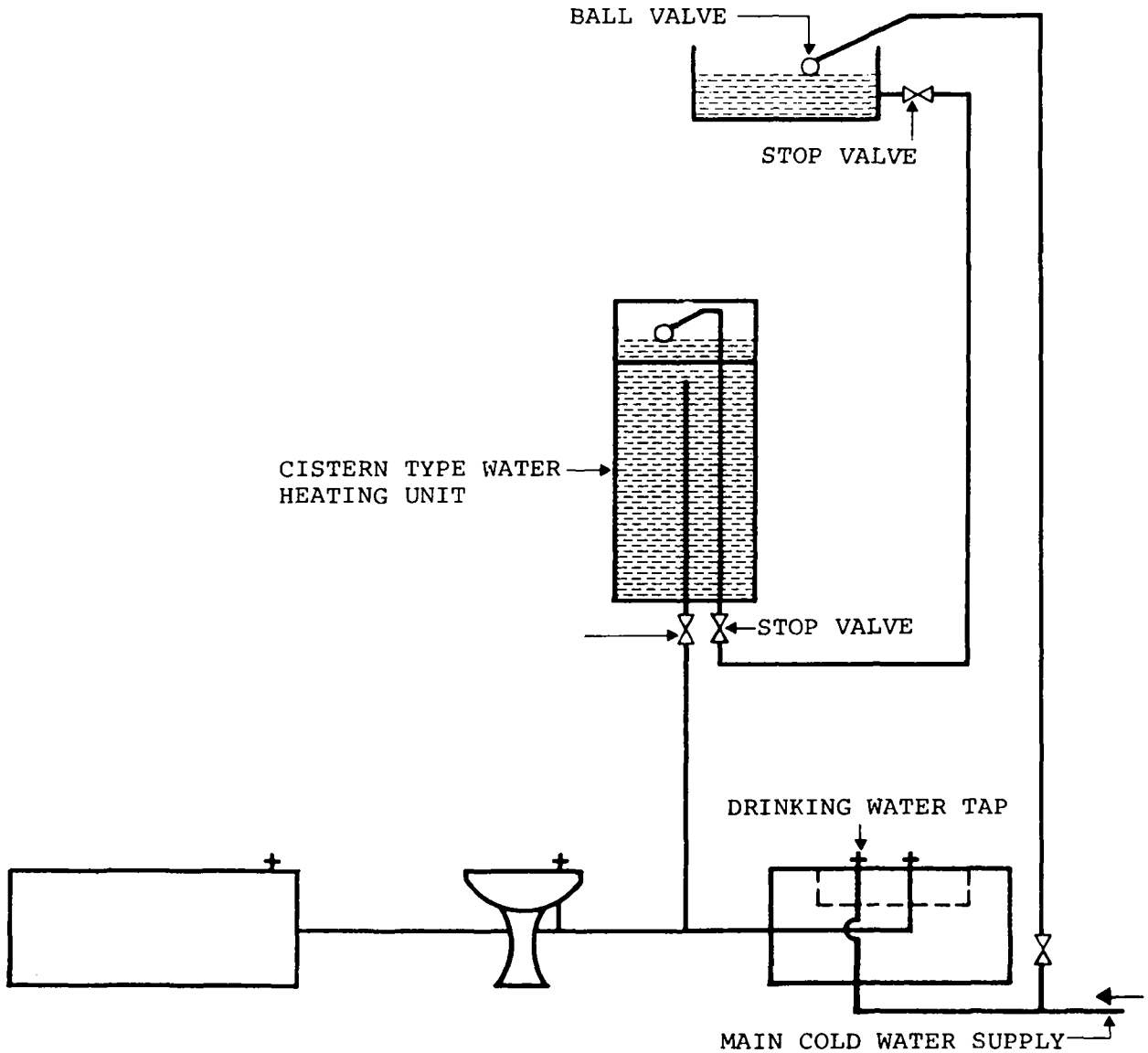

NOT TO SCALE

5. Domestic Hot Water Apparatus Apartment Block—Typical Detail