

# Primary Health Care Level Management of Trachoma

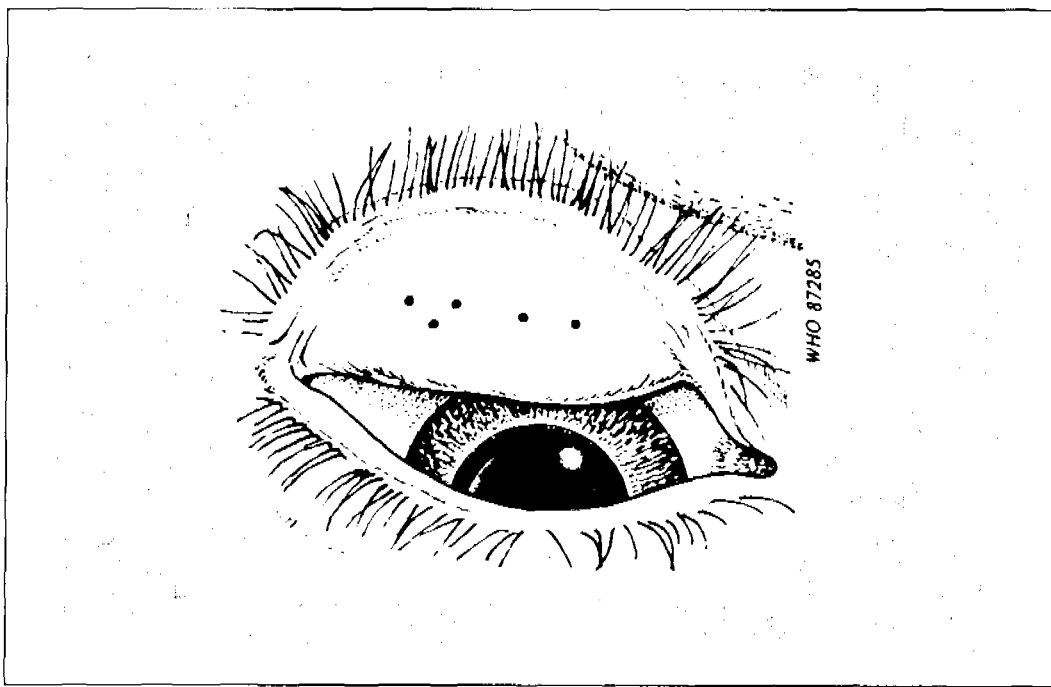

World Health Organization  
Programme for the  
Prevention of Blindness

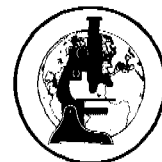

The Edna McConnell  
Clark Foundation  
New York

## ACKNOWLEDGEMENTS

The WHO Programme for the Prevention of Blindness  
wishes to acknowledge:

*the support provided by The Edna McConnell Clark Foundation  
for development of this training manual through Grant No. 10788;*

*the valuable assistance of Dr S. West in preparing part of this manual;*

*the helpful collaboration of*

*Dr C. R. Dawson, Dr H. Faal, Dr A. Foster, Dr K. Konyama,  
Dr M. B. Mmbaga, Dr R. Pararajasegaram,  
Dr M. Reacher and Professor H. R. Taylor*

*in field-testing and revising the manual material.*

This document is not issued to the general public,  
and all rights are reserved by the World Health Organization (WHO).  
The document may not be reviewed, abstracted, quoted, reproduced  
or translated, in part or in whole, without the prior written permission of WHO.  
No part of this document may be stored in a retrieval system  
or transmitted in any form or by any means - electronic, mechanical  
or other - without the prior written permission of WHO.  
The views expressed in documents by named authors  
are solely the responsibility of those authors.

LIBRARY IRC  
PO Box 93190, 2509 AD THE HAGUE

Tel.: +31 70 30 689 80

Fax: +31 70 35 899 64

BARCODE: 16923

LO:

245.2 93 PR

# Primary Health Care Level Management of Trachoma

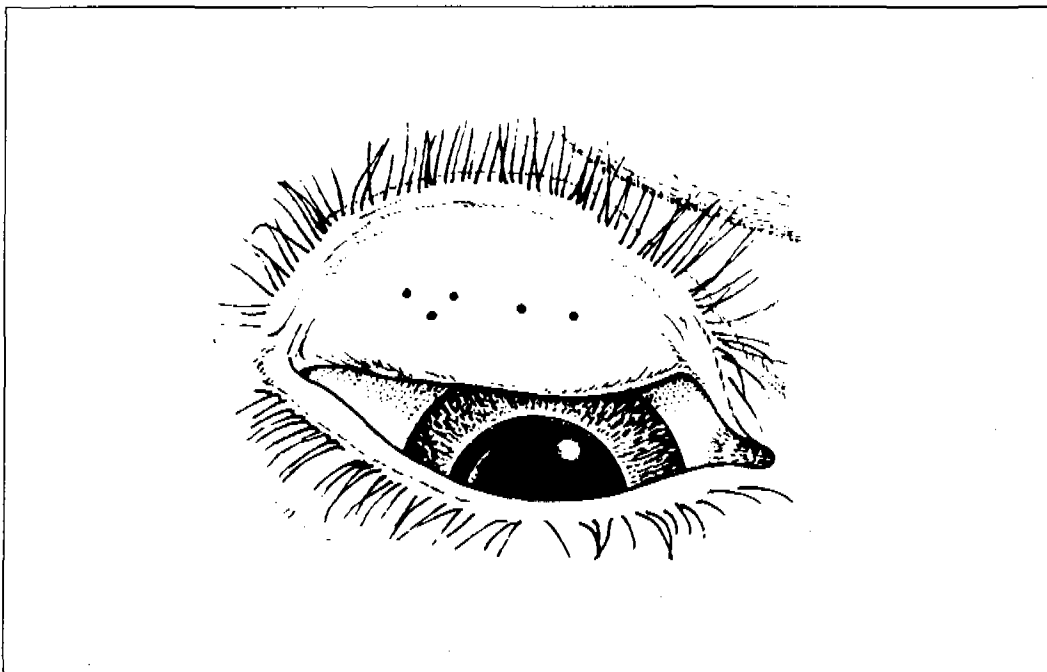

World Health Organization  
Programme for the  
Prevention of Blindness



The Edna McConnell  
Clark Foundation  
New York

## HOW LECTURERS SHOULD USE THE MANUAL, SLIDES AND RECOGNITION CARD

### 1. Planning the training session

It is important to choose a hyperendemic or mesoendemic area in which to conduct this training, so that patients showing the spectrum of trachoma are readily available.

The class should be limited to 10 to 12.

The classroom should: be large enough for everyone to sit; be dark enough to show slides all through the day; and have a blackboard or flip-chart.

Before starting, it is useful to develop a programme for the duration of the training and to make sure that all teaching material is available.

### 2. Introduction

Explain the purpose of the course and explain the programme. Encourage discussion on points that are not understood as they arise. Proceed through the book page by page. It is very useful to tell the students the number of people in that country who have trachoma and who are blind from trachoma.

### 3. What is trachoma?

Explain to the students the problem of trachoma. This may include information about trachoma in the country. The manual includes sections on: What is trachoma? (page 3), How does the disease develop? (page 4) and Trachoma in the community (page 5).

Students may ask: Why are only 6 million of the 150 million people blind, why aren't they all blind? Explain that trachoma may be mild in some areas and more severe in others. Only severe trachoma leads to blindness, and particularly in older people.

4. Explain in simple terms the **anatomy** of the eye, in particular cornea, conjunctiva and the eyelids. Make simple drawings, similar to those on page 6. Then explain and discuss the **main signs of trachoma** (page 11).

5. Discuss and demonstrate how to **examine** the eye for trachoma (page 7), including eversion of the upper eyelid.

6. **Slides** of the various signs can be used at this point to demonstrate the clinical features, or the **photographs** on the recognition card may be used:

Slide 5:	Follicles
Slide 6:	Papillae
Slide 12:	Conjunctival scars
Slide 15:	Trichiasis
Slide 19:	Corneal opacity

7. **Describe and define** the five grades in the simplified scheme (TF, TI, TS, TT, CO).

Demonstrate these grades using slides 1 to 20. It is good to emphasize the following points.

- (a) Fig. 5 is shown actual size. If looked at with loupes, the dots will be the right size for what is seen when examining a patient.
- (b) TI - the key feature here is inflammatory thickening of the conjunctiva to the extent that more than half of the tarsal plate is involved. TI is almost always associated with TF, as it reflects more severe inflammation. Often, older people with severe TS will have red conjunctiva and the deep tarsal vessels are not visible. This is **not** TI unless there is also inflammatory thickening of the conjunctiva.
- (c) TT - lower lid trichiasis occurring by itself should not be coded as TT.

- (d) Corneal opacity may be caused by many things. For grading this sign, we are concerned with whether there is a corneal opacity that meets the definition, rather than trying to establish a likely cause.
- (e) Patients will be seen who have some features of a "key" sign but not sufficient to reach the threshold to be graded present. This does not mean the eye is normal, but only that it does not meet the threshold. It is important to have a threshold or reference level, so that all examiners can use the same threshold.
- (f) It is useful to emphasize that signs will often occur together, and each should be graded and recorded.

Slides 21-30 show difficult examples of the signs for grading, which can also be used to improve the understanding of the students.

It is useful then to shuffle the slides or turn them backwards and review the slides again, asking the students to grade them.

Later, one can have the students practise completing the grading form using the slides.

It is often useful for the students to have time by themselves to review the slides and discuss them in small groups.

**8.** Explain the **significance** of the five signs as they relate to individual **patients** (page 14) and to **communities** in which surveys are to be or have been undertaken using the grading scheme (page 15).

**9.** Explain the **strategies** for community treatment and control of trachoma, using results of surveys for TF and TI in children (1-10 years) (page 16).

Emphasize the importance of health education at the family level in reducing the risk of infection, especially the importance of clean faces.

**10.** Having completed the classroom training about trachoma and the simplified grading scheme, it is then **essential to examine patients** with the students.

Most appropriate to examine are young schoolchildren (aged 6-10 years) in an area known to have endemic trachoma. Remind the students how to examine the eye and evert the upper eyelid for signs of trachoma.

Demonstrate normal, TF and TI in children. Also try to examine some adults with TS, TT and CO.

Groups of 12-16 people should be examined as a batch by three or four students and a teacher. It is important that the patients have a spectrum of the disease. They should be screened first by the teacher. Often it may be useful to select several families, examining the preschool children, the mother and the grandparents. To aid in patient identification and reidentification, it is helpful to give each patient a number. This can easily be done by writing the allocated number on the back of the patient's hand, using a water-soluble marking pen.

Each student should grade each patient individually. When all have finished, the students' gradings should be compared to the teacher's. Where they disagree, the students and teacher should re-examine that patient together and discuss the difficulties, until all are in agreement. At the completion of a batch, any patients requiring treatment should be given tetracycline ointment or referred for further treatment.

**11.** Once you are convinced that the students' results are accurate, you can **encourage them to start using the simplified grading scheme** in their daily clinics to diagnose individual patients, and also in their villages to conduct simple community surveys (section 14, "Prevalence survey", refers).

**12.** **Regular follow-up** of the health workers' performance is advised, to check that their training and skills are being used correctly. Any error in understanding or practice can then be corrected.

## **1. AIMS OF THE TRAINING MANUAL**

This manual and set of slides have been produced to assist trainers of health workers to teach a simplified assessment of trachoma.

The manual is for use by the trainer to explain how to examine children and adults for signs of trachoma and how to use the simplified grading scheme.

The slides demonstrate the clinical signs and grades of trachoma infection. They can be used in the classroom to help students to understand and correctly grade trachoma. However, it is essential to have clinical training as well, to demonstrate the signs of trachoma and its complications in individual patients.

## **2. AIMS OF THE SIMPLIFIED GRADING SCHEME**

The simplified trachoma grading scheme has been developed in order:

- (1) to facilitate for all health workers the recognition of the signs of trachoma and its complications;
- (2) to enable health workers to assist in undertaking simple surveys to identify communities in need of measures to control blindness from trachoma;
- (3) to allow for easy evaluation, by health workers, of results of trachoma control efforts in identified communities.

### 3. WHAT IS TRACHOMA?

Trachoma is an infectious eye disease which causes inflammation and scarring of the conjunctiva, the inner lining of the eyelid, thus leading to blindness. It is caused by a microorganism, *Chlamydia trachomatis*, which gives rise to the inflammation of the conjunctiva covering the inside of the eyelids. After several years of disease, this inflammation may cause scarring of the eyelid, later leading to inturned eyelashes that rub on the cornea. Subsequent loss of vision occurs because of scarring of the normally transparent cornea.

Trachoma is a very common disease, particularly in developing countries. There are at least 150 million people in the world suffering from active disease, 6 million of whom have gone blind due to the disease.

Trachoma is the second largest cause of blindness in the world, after cataract.



#### **4. HOW DOES THE DISEASE DEVELOP?**

Trachoma tends to be found in dry rural areas, where lack of water and bad living conditions may facilitate the spread of the disease.

In communities where trachoma is common, infection starts in early childhood. The first signs can be found in children of less than one year old. Trachomatous inflammation becomes increasingly intense in children up to the age of six to eight years. Scars on the inside of the eyelids, caused by trachoma, can be found in children from the age of four years. Scarring is increasingly common in older children, but the serious complications of intumed eyelashes and corneal scarring do not usually appear before adult age. Thus, blindness due to trachoma is most common in adults.

## 5. TRACHOMA IN THE COMMUNITY

The severity of trachoma can vary from one community to another because of differences in the ease of spread of infection. Repeated infections with *C. trachomatis*, or other causes of conjunctivitis, increase the intensity of inflammation, which leads to more scarring and blindness.

Children are the main reservoir of trachomatous infection, as they are commonly and heavily infected. Compared to men, women tend to have more severe trachoma, including intumed eyelashes and blindness, probably because they are repeatedly reinfected by the children for whom they care.

Some communities have a lot of blindness due to trachoma. In these communities, intumed eyelashes and corneal scarring are common in adults, particularly in older women, and intense trachomatous inflammation is common in children.

In other communities, trachoma may be less severe, although mild trachomatous inflammation may still be common. Trachoma may still be a problem in those communities because of discomfort due to repeated eye infections.

## 6. ANATOMY OF THE EYE

6.1 The diagram shows the eye from in front and from the side.

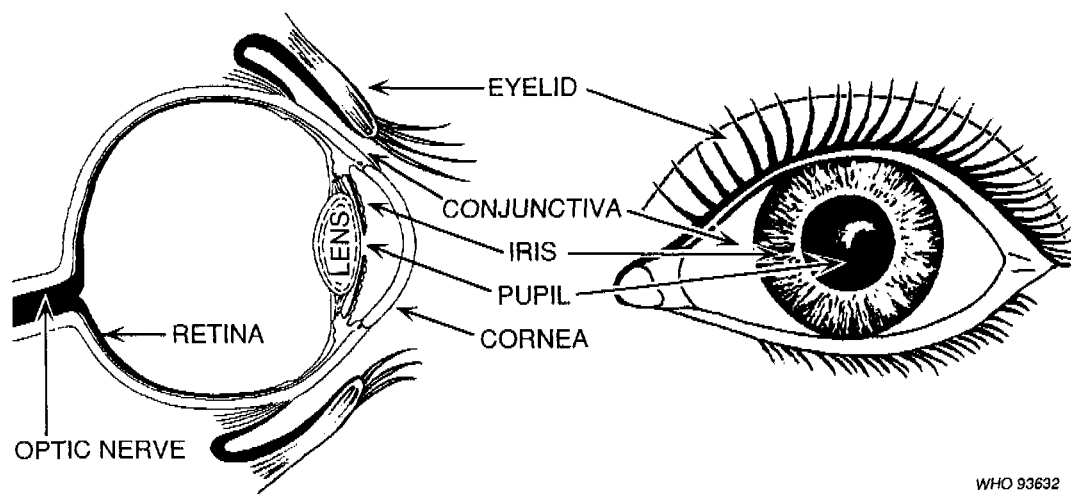

WHO 93632

Note the following structures:

1. Eyelids
2. Eyelashes
3. Tarsal conjunctiva
4. Bulbar conjunctiva
5. Cornea
6. Pupil
7. Iris
8. Lens
9. Retina
10. Optic nerve

6.2 Students may work in pairs to examine each other's eyes: the eyelashes, bulbar conjunctiva, cornea, pupil and iris.

## 7. HOW TO EXAMINE THE EYE FOR TRACHOMA

Examination of the eye for signs of trachoma and its complications should normally be performed with the aid of a binocular loupe with x2 or x2.5 magnification.

If the examination takes place indoors, a good torch is needed; if outdoors, daylight is sufficient, with the patient facing the sun.

The examination can be performed either standing or with both the patient and the examiner seated on chairs opposite each other. It is often difficult to examine children below school age without the help of their parents or other adults. In this case, the child should sit on the parent's knees. The child's head is fixed by one arm of the parent, who uses his/her other arm to hold the child's arms and body (*Fig. 1*). Alternatively, for very small children, the child's head can be fixed between the knees of the examiner, and the arms and legs immobilized by the parent. In this way, the eyes can be examined without hurting the child (*Fig. 2*). If a torch is needed, it should be held by an assistant.



Fig. 1



Fig. 2

Each eye is examined separately, normally starting with the right eye. First the eyes are examined for trichiasis, either inturned eyelashes actually rubbing on the eye or previously removed lashes. In order to check for inturned eyelashes, the upper lid is pushed upwards slightly, to expose the lid margins. The cornea is then carefully examined for opacities. Lastly, the inside of the upper eyelid, the **tarsal conjunctiva**, is examined for follicles, intense inflammation and scarring.

To examine the inside of the upper eyelid, you must first evert the eyelid. Ask the patient to look down. Gently hold the eyelashes between thumb and first finger of your left hand. Now, using a glass rod or similar instrument or your right thumb, evert the upper eyelid. Steady the everted lid with your left thumb and examine tarsal conjunctiva (*Fig. 3*). When you have finished, gently re-evert the eyelid.

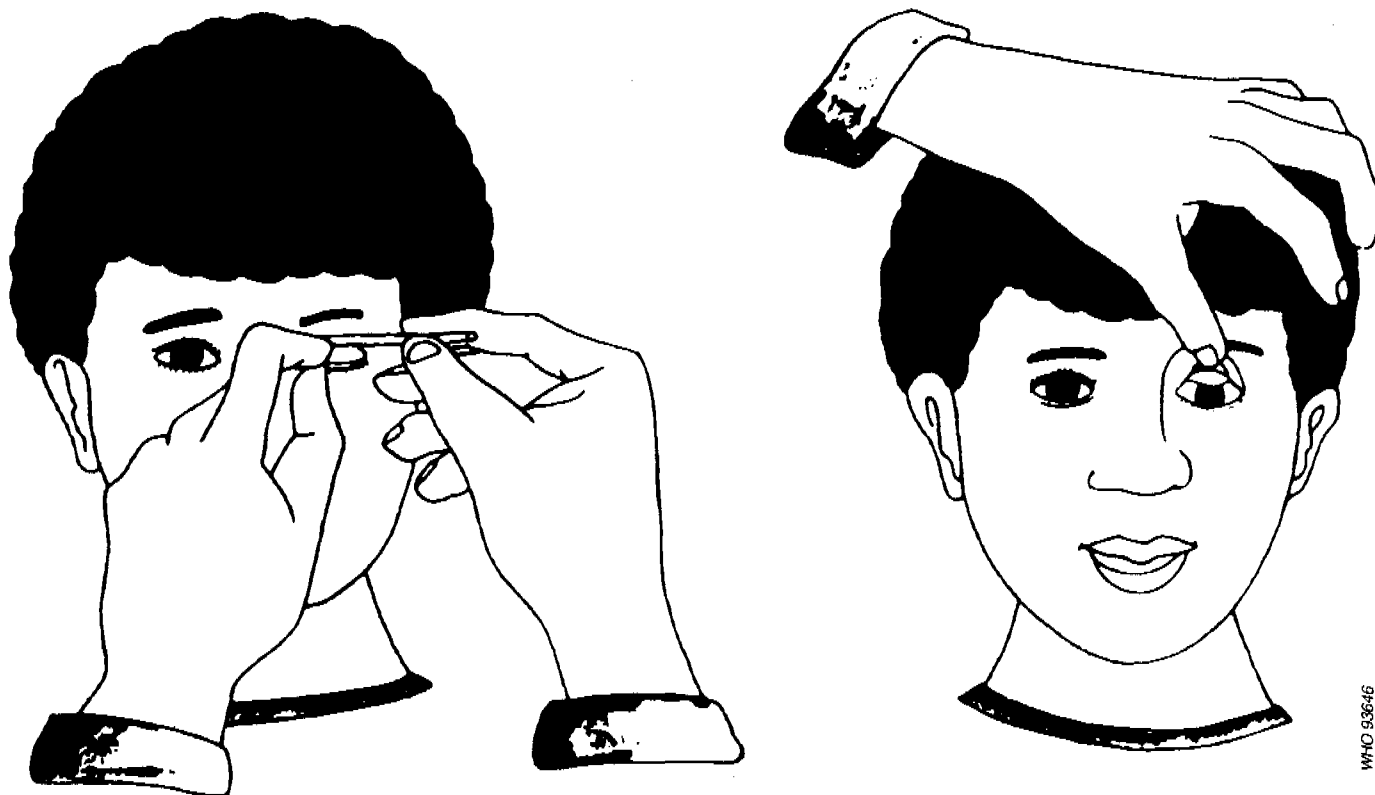
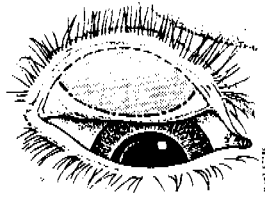

Fig. 3

The tarsal conjunctiva covers the firm part of the eyelid. The conjunctiva covering the rounded edge of the tarsal plate and the corners of the everted eyelid [palpebral conjunctiva] should **not** be examined for this purpose (*Fig. 4*).



**Fig. 4**  
Outline sketch of everted eyelid, showing the area of the tarsal conjunctiva to be examined (shaded area) for assessment of trachoma (the eye is shown at actual size)

**Slide 1**

The normal tarsal conjunctiva is pink and smooth, thin and transparent. Over the whole area of the tarsal conjunctiva there are normally large deep-lying blood vessels that mainly run vertically from the upper and lower edges of the tarsal plate.

## 8. WHAT ARE THE MAIN SIGNS OF TRACHOMA?

Trachomatous inflammation of the inside lining of the eyelids - the **conjunctiva** - starts with the appearance of small, whitish dots, 0.2-2 mm in size, called **follicles**. The conjunctiva is red and swollen, and there may be visible red dots [papillae]. In cases of **intense inflammation**, the normal large blood vessels in the conjunctiva are hidden by the diffusely thickened, swollen conjunctiva.

With time, the follicles and the inflammation are gradually replaced by **scars** in the conjunctiva. Initially, scars are small, white, glistening lines or stars, which may in time form broader bands. When there is severe scarring on the inside of the eyelid, the scars cause inturned eyelashes - **trichiasis** - which then rub on the cornea. This rapidly causes damage to the cornea, resulting in scarring, seen as a **corneal opacity**. Corneal opacification is responsible for blindness in trachoma.

Other signs may be present in trachoma, but are of less importance in the assessment of trachoma at the primary health care level. These signs include the presence of follicles at the upper edge of the cornea [limbal follicles]. They are later seen as small, round, clear windows [Herbert's pits]. This is a sign which is very specific for trachoma. Another sign is the gradual opacification of the upper part of the cornea [pannus], due to the ingrowth of blood vessels.



## 9. A SIMPLE GRADING SYSTEM

The following five "key" signs of trachoma can be used to assess trachoma and its complications.

- **TRACHOMATOUS INFLAMMATION - FOLLICULAR (TF): THE PRESENCE OF FIVE OR MORE FOLLICLES IN THE UPPER TARSAL CONJUNCTIVA**

**Slides 2-5**

Follicles are whitish round spots that are paler than the surrounding conjunctiva. In this grading system, follicles must be at least 0.5 mm in diameter.

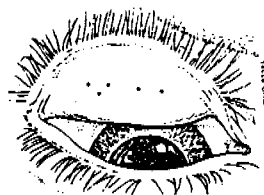

**Fig. 5**

Illustration of five follicles of 0.5 mm diameter  
on the tarsal conjunctiva  
(the eye and follicles are shown at actual size)

**Slides 6-9**

Care should be taken to distinguish follicles from small scars, or degenerative deposits in the conjunctiva. Small scars are not round, but have angular borders with sharp corners, whereas follicles have rounded edges. Degenerative deposits include conjunctival concretions that are yellowish masses with clear-cut edges, as well as cysts that appear as clear bubbles in the conjunctiva.

- **TRACHOMATOUS INFLAMMATION - INTENSE (TI): PRONOUNCED INFLAMMATORY THICKENING OF THE UPPER TARSAL CONJUNCTIVA THAT OBSCURES MORE THAN HALF OF THE NORMAL DEEP TARSAL VESSELS**

Slides 10-13

Pronounced inflammatory thickening is present when, in more than half the area of the tarsal conjunctiva, the large deep tarsal vessels are not visible because they are obscured by diffuse inflammatory infiltration or follicles. In intense trachomatous inflammation, the tarsal conjunctiva appears red, rough and thickened. This is due to diffuse inflammatory infiltration, oedema, or enlargement of vascular tufts - papillae; usually there are also numerous follicles, which may be partially or totally covered by the thickened conjunctiva. Inflammatory thickening of the conjunctiva should not be confused with that caused by scarring.

- **TRACHOMATOUS SCARRING (TS): THE PRESENCE OF SCARRING IN THE TARSAL CONJUNCTIVA**

Scars are easily visible as white lines, bands or sheets (**fibrosis**) in the tarsal conjunctiva. Characteristically, they are glistening and fibrous in appearance, with straight, angular or feathered edges. Scarring, especially diffuse fibrosis, may obscure the tarsal blood vessels, and so must not be confused with diffuse inflammatory thickening.

- **TRACHOMATOUS TRICHIASIS (TT): AT LEAST ONE EYELASH RUBS ON THE EYEBALL**

Slides 14-17

Evidence of recent removal of inturned eyelashes should also be graded as trichiasis.

- **CORNEAL OPACITY (CO): EASILY VISIBLE CORNEAL OPACITY OVER THE PUPIL**

Slides 18-20

This sign refers to central corneal scarring that is so dense that at least part of the pupil margin is blurred when viewed through the opacity. The definition is intended to detect corneal opacities that cause significant visual impairment (less than 6/18 or 0.3 vision), and in such cases the visual acuity should be measured if possible.

## 10. SIGNIFICANCE OF TRACHOMA GRADES

- TF** = Presence of trachomatous inflammation, indicating current infection. These people are normally treated with topical 1% tetracycline eye ointment (see Table I).
- TI** = Presence of intense trachomatous inflammation, indicating severe current infection with increased risk of scarring. These people should be treated with topical 1% tetracycline eye ointment. In addition, systemic antibiotic treatment may be given to individuals with very severe inflammation, not responding to the topical treatment (see Table I and page 17).
- TS** = Presence of scarring, showing that the patient has, or has had, trachoma.
- TT** = Presence of trichiasis (inturned eyelashes), indicating patients who will develop corneal opacity and visual loss; this is therefore a **potentially disabling lesion**, which may rapidly lead to blindness. These patients need corrective lid surgery.
- CO** = Presence of corneal opacity indicating people who have a visual impairment or blindness. This is a **disabling lesion**.

Other terms, commonly used in older classifications of trachoma, can be related to the present scheme:

- |  |  |
|--|--|
| "Active" trachoma                              | This implies the presence of ongoing trachomatous inflammation, corresponding to TF, with or without TI. |
| "Cicatricial", "healed" or "inactive" trachoma | Signs of trachomatous inflammation are not visible, but scarring (TS with or without TT) is present.     |

11. **KEY MEASURES FOR ASSESSING THE IMPORTANCE OF TRACHOMA IN A COMMUNITY**

- **THE PROPORTION OF TRACHOMATOUS INFLAMMATION (TF, WITH OR WITHOUT TI) AMONGST CHILDREN LESS THAN 10 YEARS OLD**

This demonstrates how **widespread** the infection is in the community.

- **THE PROPORTION OF INTENSE TRACHOMATOUS INFLAMMATION (TI) IN CHILDREN LESS THAN 10 YEARS OLD**

This demonstrates how **severe** the disease is in the community.

- **THE PROPORTION OF CONJUNCTIVAL SCARRING (TS)**

This demonstrates how common trachoma was in the **past**.

- **THE NUMBER OF PEOPLE WITH TRICHIASIS (TT)**

This indicates the immediate need to provide **surgical services** for lid correction.

- **THE PROPORTION OF PEOPLE WITH CORNEAL OPACITY (CO)**

This demonstrates the impact of trachoma in the community in terms of **visual loss**.

## 12. TREATMENT OF TRACHOMA

TABLE I. STRATEGIES FOR TREATMENT OF TRACHOMA

Proportion of children (1-10 years old) with trachoma	Basic treatment	Additional treatment
<b>TF:</b> 20% or more <b>or</b> <b>TI:</b> 5% or more	Mass topical antibiotic treatment	Selective systemic antibiotic treatment of severe cases
<b>TF:</b> 5% to 20%	Mass or individual/family topical antibiotic treatment	As above
<b>TF:</b> Less than 5%	Individual topical antibiotic treatment	Not indicated

### Mass treatment (all members of all families in the community)

Tetracycline 1% eye ointment, either twice per day for six weeks, or as intermittent treatment with ointment twice a day for five consecutive days per month, or a once-daily application for 10 consecutive days, each month for at least six consecutive months per year.

### Family treatment

Identify and treat families where there are one or more members with TF or TI; treat the whole family in accordance with one of the topical antibiotic regimens for mass treatment, as above.

## Selective systemic antibiotic treatment

Identify individuals with TI. Give one of the following:

- |               |   |   |                                      |
|---------------|---|---|--------------------------------------|
| <b>Either</b> | oral tetracycline: 250 mg x 4/day for 3 weeks   | ) | Only to children over 7 years of age |
| <b>or</b>     | doxycycline: 100 mg daily for 3 weeks           | ) |                                      |
| <b>or</b>     | erythromycin: 250 mg x 4/day for 3 weeks*       |   |                                      |
| <b>or</b>     | cotrimethazole: 2 tablets x 2/day for 3 weeks** |   |                                      |

**Azithromycin** represents a new group of long-acting macrolides (similar to erythromycin) which has shown very promising effects in the treatment of trachoma in clinical research studies. The results, so far, indicate that a single dose of azithromycin (20 mg/kg by mouth) may be as effective as six months of intermittent treatment with tetracycline eye ointment; however, further research is needed as to the optimal dose of azithromycin against trachoma - and it is still a very expensive drug.

**ENCOURAGE** GENERAL IMPROVEMENT IN FAMILY AND PERSONAL HYGIENE, ESPECIALLY KEEPING CHILDREN'S FACES CLEAN.  
GENERAL USEFUL MEASURES INCLUDE IMPROVED WATER SUPPLY, FLY CONTROL, AND DISTRIBUTION OF ANTIBIOTIC OINTMENT FOR CASES OF ACUTE CONJUNCTIVITIS WITH DISCHARGE FROM THE EYES.

(See further the manual entitled *Community treatment of trachoma*, WHO/PBL/93.36.)

---

\* For children of less than 25 kg, dosage is generally 30 mg/kg body-weight daily, in four divided doses. Observe children daily for nausea and vomiting; if severe, discontinue treatment.

\*\* For children of 6-12 years: half the dose. Children of <6 years: mixture as prescribed. Check daily for skin rash; if apparent, discontinue treatment.

Slide no.	Grading	Remarks
1	-	Normal tarsal conjunctiva
2	TF	
3	TF	
4	TF+TI	
5	TF+CO	
6	TF+TI	
7	TI	There are a few follicles, but it is not possible to identify five follicles of adequate size.
8	TF+TI	Strands of mucus can be seen, but no scars.
9	TF+TI	There are no easily visible scars.
10	TF+TS	
11	TS	The scars are just sufficiently visible for grading as TS.
12	TS	There are also typical Herbert's pits along the upper corneal limit.
13	TS	
14	TT	There is a cataract giving a whitish pupil, but the pupil can be clearly seen.
15	TT	
16	TT+CO	The broken and missing eyelashes are evidence of recent removal of lashes. There is also a pterygium.
17	TT+CO	
18	CO	
19	CO	
20	TT+CO	

The following slides demonstrate some difficult examples of signs of trachoma, or other manifestations; these slides may therefore be used for practice, once the basic definitions and signs have been learned.

Slide no.	Grading	Remarks
21	TF	This is obviously TF, but there are large follicles outside the tarsal conjunctiva; this is <b>not quite</b> TI.
22	TF+TS	
23	TI+TS	There are some large follicles present, but not five of those clearly seen. This slide shows a typical pattern of interlocking "basket-weave" scarring. The deep tarsal vessels are not visible, partly due to scarring, but mainly due to inflammation.
24	TS	This is also a good example of concretions.
25	TI+TS	It is not possible to make out five follicles of sufficient size. Scarring is obvious. The majority of deep vessels are obscured, partly by scarring, but mainly by diffuse inflammatory thickening.
26	TF+TS	There are linear scars with a membrane over the tarsal conjunctiva. Note there is also a pannus.
27	TF+TI+TS	
28	-	Not trachoma. It is <b>not</b> TF; insufficient follicle size.
29	TF+TI+TS	
30	TT+CO	



### **13. DO ALL THE EXAMINERS UNDERSTAND THE SYSTEM?**

#### **A. Setting up a reliability study**

It is important to know, before undertaking any trachoma surveys, that all the trachoma examiners are using the system in a similar fashion.

Evaluation of reliability is an essential step which must be taken before any epidemiological survey on trachoma. It is particularly important in long-term surveillance of trachoma control programmes. Periodic surveys can be conducted after a year or more, to judge the impact of a control programme. The reliability study ensures that the examiners are always grading trachoma in the proper way. Some of them can go astray after a few months out of practice unless they receive on-the-job training; they should therefore be reassessed periodically. It can thus be ensured that the examiners work in the same way and that their observations tally.

The easiest way to check the reliability of all examiners is to make everyone grade trachoma on the same individuals. At the end of a series of examinations, a tally can be made of these grades and the extent to which the results agree. No individual's trachoma grade alters between examinations on the same day, so any discrepancies must be due to differences in the way the examiners are grading. The process is described in more detail below.

1. The senior examiner should select a total sample of about 50 people, including both children and adults. Some of these would have the various signs of trachoma, while others would have no sign of the disease. It is usually easy to find cases of TF and/or TS to organize this type of evaluation, although other signs (TI, TT and CO) may not be sufficiently numerous in a group for inclusion in a reliability study. By and large, the sample should include at least 15 to 20 people presenting the sign in question, so that analysis of agreement can have some value. Everyone in this group of people should be given an identification number, beginning with 01. The number can be written on a card and given to the person to show each trachoma examiner.

- Each examiner should have a pile of grading forms, like the one shown below. The examiner's name or code number should be entered at the top of each form. One form should be used for each person examined by each examiner.

**SAMPLE DATA FORM**

**Reliability test**

<b>Trachoma examiner:</b> (Your name or code) ..... <b>Patient ID:</b> <u>01</u>																						
<p><b>WRITE ONE OF THE FOLLOWING CODES FOR EACH SIGN</b></p> <p>0 = Absent 1 = Present</p> <table style="margin: auto; border-collapse: collapse;"> <thead> <tr> <th style="padding: 5px;"></th> <th style="padding: 5px;">TT</th> <th style="padding: 5px;">CO</th> <th style="padding: 5px;">TF</th> <th style="padding: 5px;">TI</th> <th style="padding: 5px;">TS</th> </tr> </thead> <tbody> <tr> <td style="padding: 5px;"><b>Right eye</b></td> <td style="width: 50px; height: 40px;"></td> <td style="width: 50px; height: 40px;"></td> <td style="width: 50px; height: 40px;"></td> <td style="width: 50px; height: 40px;"></td> <td style="width: 50px; height: 40px;"></td> </tr> <tr> <td style="padding: 5px;"><b>Left eye</b></td> <td style="width: 50px; height: 40px;"></td> <td style="width: 50px; height: 40px;"></td> <td style="width: 50px; height: 40px;"></td> <td style="width: 50px; height: 40px;"></td> <td style="width: 50px; height: 40px;"></td> </tr> </tbody> </table>						TT	CO	TF	TI	TS	<b>Right eye</b>						<b>Left eye</b>					
	TT	CO	TF	TI	TS																	
<b>Right eye</b>																						
<b>Left eye</b>																						

- The first person is seen by the senior examiner (examiner No. 1), who first enters the individual's number, 01, and then proceeds to grade for signs of trachoma. After this, the person moves on to examiner No. 2, who is not aware of the earlier grading. Examiner No. 2 enters the individual's code number and independently records his grading. Individual 01 then moves on to the next examiner and the process is repeated until all the selected individuals are seen in turn by all the trachoma examiners (see diagram below).

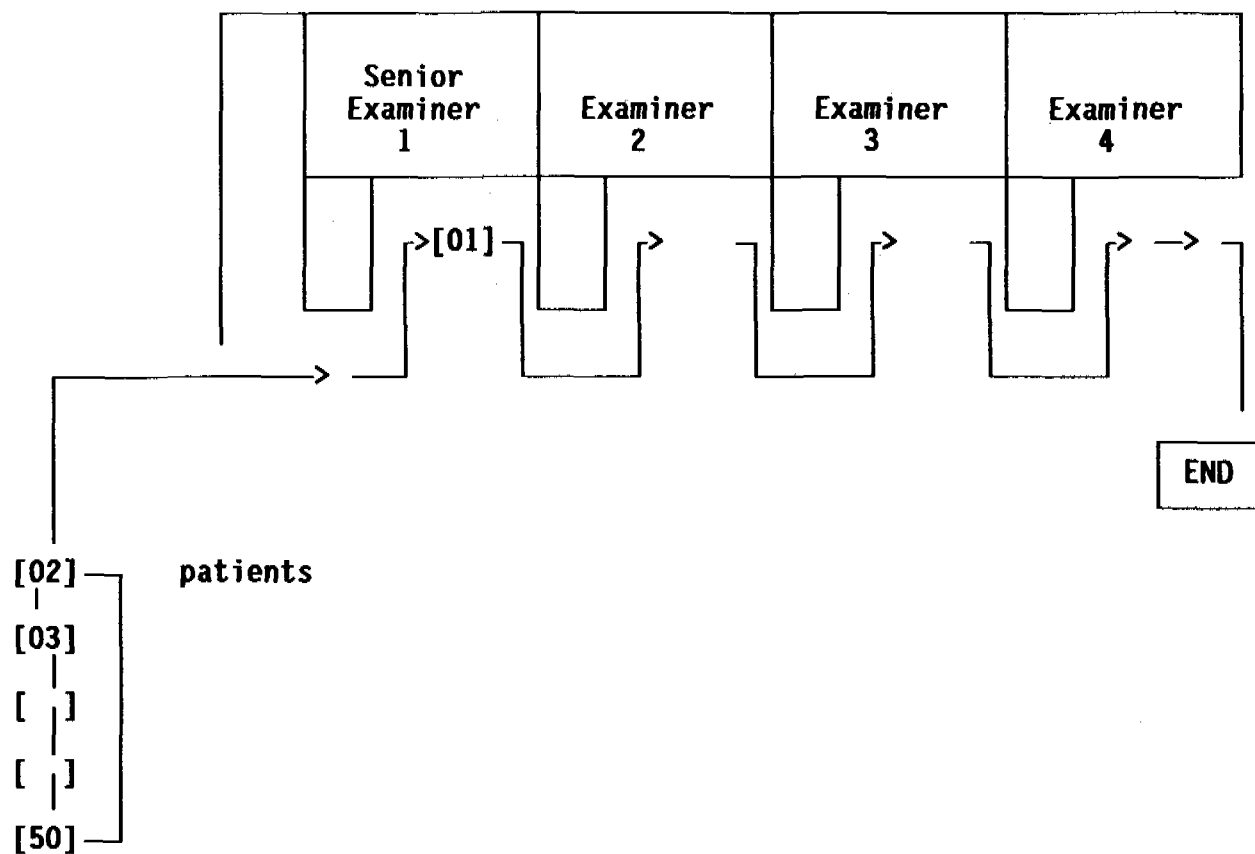

4. At the end of this exercise, each trachoma examiner will have a pile of forms equal to the number of persons individually and independently graded. Ideally, **each** examiner should be in agreement with the **senior examiner** and, therefore, with the others in the grading.

The following section describes how to determine whether this is true.

## B. Comparing results among examiners

Forms completed by the senior examiner and one trainee examiner are paired according to the patient's identification number. These paired forms are then sorted into four piles based on the agreement between the two examiners: the first pile will contain all the pairs of forms on which the two examiners noted the same sign, for example "TF"; the second pile will contain all the matches where both the examiners agreed that the sign (TF) was not present. The remaining two piles would denote disagreements - one pile in which the senior examiner recorded that the sign (TF) was present, while the other examiner said it was absent ("underscoring"), and the other pile where the senior examiner said that the sign (TF) was absent, but the other examiner recorded that it was present ("overscoring").

A form like the one below should then be completed, indicating for each category the number of pairs of forms filled in [A, B, C and D;  $n$  representing the total number of people examined:  $(A+B+C+D)$ ].

		Senior examiner (E)
Other examiner (O)	Sign	
	+	
	—	
	+	
	—	
	(A) and (D)	
	(B)	
	(C)	

A (+,+)	B (-,+)	
C (+,-)	D (-,-)	
		$n$

+	:	sign present
—	:	sign absent
(A) and (D)	:	agreement
(B)	:	overscoring
(C)	:	underscoring

	disagreement
--	--------------

In order to obtain an idea of the agreement, add together the number of matches where both examiners agreed and divide the result by the total number examined. The percentage agreement should be at least 80%. A similar table is used for each of the five signs of trachoma.

The same process can now be repeated for all the other examiners in turn, testing or verifying their agreement or disagreement *versus* the senior examiner.

### **C. What do the results mean?**

If the agreements for each sign are all around 80% or higher, the grading system can be fully relied upon. If, however, the percentage is lower, it will be necessary to see where the problem lies by looking at the **disagreements**, in the paired forms for disagreement. Where there is "agreement", the senior examiner (E), whose diagnosis becomes the reference, and the other examiner (O) both declare that the sign is present (+) or absent (-).

In cases of "disagreement", their opinions on a given case differ. There are two possible explanations:

#### **(1) Failure to recognize**

O does not see the sign (-), while E does (+).

This means that O tends to underestimate the sign.

#### **(2) Mistaken recognition**

O declares the sign present (+), while E does not (-).

This is an example of overscoring on the part of examiner O.

These possibilities can be presented in the form of a 2x2 contingency table (four possibilities: A, B, C and D). An example is shown below.

**SPECIMEN TABLE OF AGREEMENT/DISAGREEMENT  
AND  
ANALYSIS OF RESULTS**

Fifty subjects were examined for TF by the senior examiner (E) and his future assistant (O) (in this sample, E listed 29 cases of TF).

When the examination forms completed by E (reference) and O are matched, the following table can be prepared:

TF		E		
		+	-	
O	+	24	3	
	-	5	18	
TOTAL		29	21	$n = 50$

Agreement and disagreement are calculated as follows:

**Agreement**

$$[(+, +) + (-, -)]/n$$

$$\frac{24 + 18}{50} \times 100 = 84\%$$

**The minimum acceptable level of agreement is 80%.**

**Disagreement**

(1) underevaluation:  $(+,-)/n$

$$\frac{5}{50} \times 100 = 10\%$$

(2) overestimation:  $(-,+)/n$

$$\frac{3}{50} \times 100 = 6\%$$

(3) disagreement:  $[(+,-) + (-,+)]/n$

$$\frac{5+3}{50} \times 100 = 16\%$$

The above is only a brief and simple way of testing observer variation. If there is a need for a more detailed analysis, a statistician should be consulted.

## 14. THE PREVALENCE SURVEY

### Introduction

This second section tells how to gather sufficient data for preparation and evaluation of a trachoma control component within a national programme for prevention of blindness. It is not a detailed description of a rigorous scientific survey on trachoma; a statistician/ epidemiologist should be consulted for that purpose.

Before a trachoma control programme is initiated, all the necessary data must be available. Such data can be obtained either from hospital records or from the records of mobile units, or by interviewing health personnel working at the peripheral level. Yet data on clinical consultations (number of cases of acute follicular trachoma, number of surgical operations on the eyelid) lead to underestimation of the scope of the problem; many sufferers do not have recourse to health services and are therefore never counted. This is why a small-scale **survey** in the general population is often necessary.

### A. Principles of a prevalence survey

The most accurate way of finding out the trachoma situation in a community is to undertake a prevalence survey. This means that the proportion of cases of disease and complications is assessed at a given moment (cross-sectional) in terms of **prevalence**, in relation to the total examined population under study.

1. It is important that there be a clear **objective/purpose** of the survey. In most instances it will be to find out the prevalence of active inflammatory disease (TF and/or TI) or ensuing complications (TT). These are the variables that will determine the need for medication or surgical treatment.
2. There should be a well-defined **target population** for the survey. As a general rule for simplified trachoma surveys, it is recommended to consider only **rural** populations, and only communities with less than 5000 inhabitants. Those are the settings where trachoma is most likely to be a significant cause of visual loss.



3. Most surveys require a **sampling** of the population concerned, i.e., only a portion, determined according to a defined procedure, will be examined, in order to save on work and cost. The common principle in all samples is **randomization**, implying that villages, households or individuals are selected at random, to be representative of the whole population concerned.

The ideal is to have a simple random sample, drawn from a list of all the people in the study area. This is not practical, however, and groups of households or individuals are therefore often examined, which makes the survey work easier and more effective. Each group is called a **cluster**.

When cluster sampling is used, the sample is determined in two or more steps (multistage). For the present study, the first step will be to sample **villages**. The second step is to select **households** in the chosen villages. All the individuals belonging to the identified households should then be included in the sample.

4. For trachoma assessment, it is usually enough to estimate the prevalence of disease and complications in the total population of administrative or health care units; in the present manual, the assessment refers to the **district** level.

## **B. Selecting the sample**

The choice of the sample is governed by certain conditions:

### **1. REPRESENTATIVENESS**

The villages or communities selected must faithfully reflect (represent) all the villages or communities in the survey zone. This means that, if communities are chosen because they are near a dispensary and easily accessible, the survey will not show the real epidemiological situation of trachoma in the study area.

The people to be examined in each village or neighbourhood should be representative of the local population. If the village is very small, all inhabitants should be examined. Otherwise, people should be chosen from all social classes and from all parts of the village.

The results of the survey can be extrapolated to the whole population of the area **only if the sample is deemed representative of the population from which it is drawn.**

## 2. THE SAMPLING FRAME

This refers to the setting and information needed to be able to select correctly a sample in a given area.

A **census** for the district is needed, listing all **villages** with their populations. If the census is old (more than five years), it needs to be updated, making use of more recent information as far as possible (recent health surveys, school records, population increases, etc.). A recent map of the entire district, with the location of each village, is very useful.

Sometimes the census enumeration areas combine several villages and, therefore, information on the population of each village is not available. In this case, census enumeration areas should be used in place of villages.

A complete **listing of all households** in selected villages may be found from a recent census or other registration system. These data may also be available from other sources: for example, immunization coverage or agricultural development programmes. Detailed maps of the area are also useful. Care should be taken to be sure that the listing of households is complete and includes all sections of the village. If a complete listing is not available, it will be necessary to create one by walking through the village and writing down each household.

## 3. SAMPLE SIZE

Trachoma is an infectious disease, and it will thus be more common in certain families, neighbourhoods and villages; therefore, individuals within selected clusters tend to resemble each other and present a certain homogeneity. This homogeneity should be taken into consideration when determining the sample size.<sup>1</sup>

---

<sup>1</sup> Thus, if it is intended to examine more people per village, the sample size should be further increased to compensate for the "cluster effect". The rate of homogeneity ( $\rho_{oh}$ ) is the statistic used to measure homogeneity.

The size of the total sample to be selected will depend on the "expected" prevalence of the sign in question, on the degree of accuracy required of the estimate, and on the number of individuals to be examined in each cluster.

The larger the acceptable confidence interval, the smaller the sample size. Thus, it may be helpful to confine the examinations to groups at high risk for trachoma. For example, it may be decided to confine the sample for the estimate of TF and/or TI to children under the age of 10. This group could be expected to have more active, inflammatory cases. For assessing signs of trichiasis or corneal opacity, on the other hand, the sample could be confined to women over the age of 15. The "key" prevalences for operational decisions are: TF >20% and TI >5% in the 0-9 years age group; TT >1% in women over 15 years of age (see further pages 39-40).

**Example**

*It should be noted that the following section is based on certain assumptions and simplified approaches. This model gives reasonably accurate estimates, as a basis for operational decisions; but if a more sophisticated or large-scale assessment is planned, a statistician/epidemiologist should be consulted for a detailed sampling.*

**Stage 1**

**Choice of villages from which the clusters are selected.** First of all, a list must be made of all the villages or census enumeration areas in the survey area, giving the precise or estimated number of inhabitants of each (the sampling frame). Communities are selected with "probability proportional to size", so that communities of equal population will have the same chance of being chosen to provide a cluster, while communities with larger populations will have a proportionally greater chance.<sup>1</sup> An example of this sampling procedure is given below; it also takes into account the grouping of villages into categories of known or suspected trachoma-endemic communities (implicit stratification).

---

<sup>1</sup> Only villages with a population of less than 5000 inhabitants may be considered.

***District "X" contains 60 villages with a total population of 100 000. A sample of 4000 persons composed of 20 clusters should be drawn from the total population. This is based on the following considerations:***

- (i) To identify the least common sign, TT, with reasonable accuracy (see section D), at least 50 women aged 15 years or more should be examined in each village (cluster).
- (ii) At least 20 clusters should be included in the sample (see section D).
- (iii) A field team may easily examine 200 persons/day.

**Step 1**

Prepare a complete list of villages in the district, with the known or estimated population in each village. This is the sampling frame.

<b>SAMPLING FRAME</b>	
<b>Village</b>	<b>Population</b>
**1	4000
*2	1000
3	1200
*4	450
58	13 000
**59	700
60	7000

**Thus: 60 villages, 100 000 population**

**Eliminate** villages of more than 5000 population, for simplicity of field work.

**Step 2**

Now **group** the villages into **three** categories of known or estimated endemicity. Mark this in the above table as follows:

- (i) Villages with **STRONG** evidence of severe disease, i.e., previous surveys, visiting health teams' reports, etc.: *mark these villages with two asterisks, or similar, next to their number.*
- (ii) **SOME** evidence of trachoma, but probably little or mild disease, as judged by anecdotal or few patients' evidence: *mark these villages with one asterisk, next to their number.*
- (iii) **NO** evidence of trachoma in the village: *no mark needed.*

**Step 3**

To identify the 20 clusters needed, a table is set up (see below):

- First the category of village endemicity (strong, some, none, as from the previous table)
- Column 1 with the identification of each village
- Column 2 with the total population of that village
- Column 3 with cumulative population, adding each village population to the previous ones
- Column 4 will contain the identified clusters, as per instructions.

Category	1 Locality	2 Population	3 Cumulative population	4 Identified clusters
<b>STRONG</b> evidence of prevalent and severe trachoma	1	4 000	4 000	3 392 = Cluster 1
	5	1 000	5 000	
	11	1 500	6 500	
	13	4 500	11 000	7 392 = Cluster 2
	17	600	11 600	11 392 = Cluster 3
	26	2 100	13 700	
	30	500	14 200	
	31	1 000	15 200	
	39	1 600	16 800	15 392 = Cluster 4
	43	350	17 150	
	48	650	17 800	
	54	3 000	20 800	19 392 = Cluster 5
59	4 900	25 700	23 392 = Cluster 6	
<b>SOME</b> evidence of trachoma but little or mild disease	2	1 000		Clusters 7-19
	4	450	etc.	
	etc.	etc.		
	24 villages			(75 392 = Cluster 19)
<b>NO</b> evidence of trachoma	3	1 200	76 200	79 392 = Cluster 20
	7	1 100	77 400	
	14	700	78 500	
	etc.	800	79 200	
	21 villages		80 000	
Random number = 3392 Sampling interval = 4000				

NOTE: Two villages of 13 000 and 7000 inhabitants were excluded (Nos 58 and 60).

**Step 4**

**Calculating the sampling interval**

Divide the total cumulative population (80 000) by the requisite number of clusters (20) to calculate the sampling interval (SI):

$$SI = \frac{80\,000}{20} = 4000$$

**Step 5**

**Drawing a random number and identification of the first cluster**

Use a random numbers table or a pocket calculator with a random numbers function (or the serial numbers of bank notes) to choose a random number between 1 and the sampling interval (4000). For this example, the number is 3392. It can be seen from the "Cumulative population" column that 3392 is less than 4000, the population of the first village. The first cluster is therefore taken from the first village. Report it in column 4 of the table.

**Step 6**

**Identification of remaining clusters**

To find out from which village the second cluster should be taken, add the sampling interval (4000) to the number chosen at random (3392); this makes 7392, which falls between 6500 and 11 000 in the "Cumulated population" column; the second cluster therefore comes from village 13. Repeat this operation to identify the other villages. Two or more clusters could come from a single community if its population were greater than the sampling interval (SI).

This **first** stage of sampling identifies the **villages** in which a cluster of households should be examined.

**Stage 2**

**Selection within those villages of the households to be included in the sample.**

The cluster consists of **all** the members of these households. This stage consists of defining the clusters and identifying the people in them. From the **full** list of households in a community, certain households are selected to provide the requisite number of subjects. The examiner does not begin his work until **all** the households are identified and numbered, and all their members are registered. Use a **local census** listing and **detailed map** for numbering and choosing the households for examination.

**Step 7**

Determine the number of households constituting each cluster.

**Step 8**

At least 50 women aged 15 years or more must be examined in each village to be able to tell if the prevalence of trichiasis is more than 1% (see further section D).

Assuming that women constitute 50% of the total population, and that 50% of women are above 15 years of age, there is a need to examine 200 persons (both sexes and all ages) in each village cluster. This will give the required precision of the prevalence of trichiasis.

**Step 9**

If we estimate the average size of a household to be eight people, with an average of two women aged 15 years or more, we need to examine, on average:

$$\frac{200}{8} = 25 \text{ households per village}$$

**Step 10**

**Check** the total number of households in the selected village cluster.

Then **divide** by the number of estimated needed households (in this case 25). For example:

300 households in the village

Divide by 25 = 12

Thus, **every twelfth household** throughout the village should be examined, with all its members.



**Step 11**

**Decide** on the most practical way to select and examine each twelfth household, making use of lists and maps. Steps 4-6 can be applied in principle, i.e., the sampling interval is 12 in this case (300/25) and a random number between 1 and 12 can be drawn to identify the first household on a numbered list of households or a map. The subsequent households are then identified as in Step 6.

**Step 12**

**Define and follow strictly rules for:**

- abandoned households (another household should be selected at random);
- revisits, if people are absent;
- additional households, to be selected if needed (there must be a minimum of 50 women examined in each cluster of households).

**C. Conducting the survey: resources and costs**

This kind of fast, simple survey is not usually very expensive. The main expenditure is on transport, equipment and supplies. Additional funds should be allocated to wages and data analysis.

**1. TRANSPORT**

Transport is needed to ensure access to each of the clusters selected. In many regions, transport is a big problem. If the households in the cluster are scattered, some form of transport must be provided for travel in the cluster (one or more visits to each household). The examinations can be conducted either when the households have been brought together or in the course of home visits. Whereas it is easier to find people in their homes, such an approach takes longer. Either way, when the population is very scattered, it is better to make home visits even in large villages, where only a few (selected) households have to be examined.

**2. EQUIPMENT AND SUPPLIES**

The trachoma examiner and the team will need simple equipment (loupes and torches) and drugs (tetracycline eye ointment). During the survey, the examiner may have to treat routine medical problems; he should therefore bring antibiotics, antimalarials, aspirin, etc. For systematic gathering of standardized data, the examiner should have a sufficient number of **record forms**. A simple and practical specimen is shown below.

**SPECIMEN FORM FOR REGISTRATION OF DATA  
FOR THE EPIDEMIOLOGICAL SURVEY OF TRACHOMA**

<b>EPIDEMIOLOGICAL SURVEY OF TRACHOMA</b>					
<b>Examiner:</b> <u>Mazengo</u>					
<b>Subject examined:</b> <u>Judith Oh</u>	<b>Village:</b> <u>Makawa</u>				
	<b>Household no.:</b> <u>31</u>				
	<b>Sex:</b> <u>F</u>				
<b>ENTER ONE OF THE TWO FOLLOWING SYMBOLS FOR EACH SIGN</b>					
<b>0 = Absent</b> <b>1 = Present</b>					
	<b>TT</b>	<b>CO</b>	<b>TF</b>	<b>TI</b>	<b>TS</b>
<b>Right eye</b>	0	0	0	0	1
<b>Left eye</b>	0	0	0	0	1

**3. THE TEAM**

The personnel required for field work may simply be the trachoma examiner and an assistant. On occasion, there might be an advance team that would undertake the mapping and census work. The examiner could be accompanied by a driver and one or two assistants who would help with the examinations and registration of results. The assistants could be recruited in the area and could help locate the households. There should also be clerical support for tabulating (or coding) the initial forms and processing the data.

#### 4. THE TIMETABLE

Another factor that must be considered is the time involved. This depends on the number of health workers operating in the field, the size of the sample, and local geography.

#### 5. ANALYSIS

Tabulation and "manual" analysis of data need not cost much, setting aside staff costs. If data are processed by computer, then the cost of data-processing must be taken into account.

#### D. Data analysis

1. After the survey, the form must be put together, checked for completeness, and analysed. First, consider the **attendance**, e.g. how many people were actually examined out of all those listed?

##### Example:

It was envisaged to examine a sample of 900 people in 30 clusters. In fact, only 800 of the total census population of 900 were actually examined.

Thus, attendance was (%):  $\frac{800}{900} \times 100 = 88.9\%$

As a rule, an attendance rate of **more than 85%** is considered satisfactory. For a more detailed analysis, the attendance for each age group and by sex may be calculated.

2. To be able to consider the **representativity** of the examined sample, a comparison by age group and sex must be made to the known population structure ("age pyramid") in the area.

3. **Prevalence** is the easiest indicator to calculate.

**Example:**

If 200 people are examined and 10 have evidence of TT in one or both eyes, the prevalence of trichiasis is (%):

$$\frac{10}{200} \times 100 = 5\%$$

It is always useful to estimate specific prevalence by age, village and district of active trachoma and of trichiasis, as this implies the need for treatment to be provided. For the prevalence of "active trachoma", both TF and TI should be considered, in particular as to the possible need for mass ("blanket") treatment of a community.

As a routine data analysis procedure, proceed as follows:

1. Calculate the prevalence of TF and/or TI by age group, as shown in Table II (page 42). This is referred to as "**active trachoma**"; check the rate for children  $\leq 10$  years of age and compare to the recommended strategies for treatment (page 16).
2. Now look at the prevalence of TI by the same age groups. Again verify the rate for children  $\leq 10$  years of age, and compare to the recommendations for treatment (page 17). This is referred to as "**intense trachoma**".
3. Finally, calculate the prevalence of TT in the age group  $\geq 15$  years; by far, most cases of trichiasis will be in that age group. It may therefore be useful to refer to "**trichiasis**" by age group, for example "2% of the population above 15 years". This facilitates the estimation of surgery needed in other areas, where the composition of population age may be different.

NOTE: *If the above model for sampling is applied, the 95% confidence interval implies the following:<sup>1</sup>*

- *To be 95% sure that the district prevalence rate of TT in women is more than 1%, the "survey prevalence" found in women more than 15 years old should actually be 2.5%.*
- *To be 95% sure that the district prevalence rate of TI in children 0-9 years is more than 5%, the "survey prevalence" should be at least 8%.*
- *To be 95% sure that the district prevalence rate of TF in children 0-9 years is more than 20%, the "survey prevalence" should be at least 25%.*

In addition to the above three points, it is often useful to calculate the TS rate by age group. This may be referred to as "**conjunctival scarring**", which in children  $\leq 10$  years of age gives an idea as to the severity of trachoma in the population and the future need for trichiasis surgery. However, this "scarring" is more useful in estimating trends over time, to measure a **change** in the disease, as not all children with TS will develop trichiasis.

The prevalence of CO, finally, gives an indication of how much visual loss may be caused by trachoma, and it is again useful to calculate this by age group. This may be referred to as "**corneal opacity**"; it can be used to measure change over time of the disease. However, it is a long-term indicator, as the overall CO rate will change very slowly, but there should gradually be less of it, after a few years, if the prevention and treatment of trachoma have been successful in an area.

There is often a difference between **males** and **females** with regard to trachomatous inflammation and complications; usually, females tend to be more affected. The data analysis can, of course, be done also by sex in addition to age, but it is less imperative unless there are very marked differences leading to a change in treatment strategy.

---

<sup>1</sup> This is based on the assumption that at least 50 women aged 15 and over are examined in each of 20 villages. The assumed rate of homogeneity ( $\rho_{oh}$ ) was 0.8 for TF and TI and 0.4 for TT. In addition, to calculate the finite correction factor it was assumed that there were 60 villages in the district.

NOTE: *The overall prevalence of trachoma is often referred to. It is generally not a useful measure of the disease, as it does not tell anything about present or past intensity or complications of trachoma.*

Of course, computer processing of the data makes statistical analysis easier. If no computer is available, then simple tables filled in by hand give information which is just as good on the scale and severity of trachoma. Table II is useful for a detailed analysis of all signs of trachoma by age group and sex. For more detailed analysis, an epidemiologist/statistician should be called in, or reference books on calculation of other variables should be consulted.

TABLE II. SUGGESTED TABLE FOR OVERVIEW OF DISTRIBUTION OF THE KEY SIGNS OF TRACHOMA, BY AGE AND SEX

Age Signs of trachoma	0-9			10-14			15+			Total		
	Male	Female	Total	Male	Female	Total	Male	Female	Total	Male	Female	Total
	N(%)	N(%)	N(%)	N(%)	N(%)	N(%)	N(%)	N(%)	N(%)	N(%)	N(%)	N(%)
Active trachoma (TF+TI)	62(31.6)	67(32.8)	129(32.3)	14(18.2)	17(23.3)	31(20.7)	11(10.0)	18(12.8)	29(11.6)	187(22.7)	102(21.5)	189(23.6)
Intense trachoma inflammation (TI)	19(9.7)	21(10.3)	40(10.0)	2(2.6)	4(5.5)	6(4.0)	0(0.0)	5(3.6)	5(2.0)	21(5.5)	30(7.2)	51(6.4)
Trachomatous trichiasis (TT)	0(0.0)	0(0.0)	0(0.0)	0(0.0)	0(0.0)	0(0.0)	4(3.6)	16(11.4)	20(8.0)	4(1.0)	16(3.8)	20(2.5)
Trachomatous scarring (TS)	14(7.1)	6(2.9)	20(5.0)	13(16.9)	17(23.3)	30(20.0)	44(40.0)	47(33.6)	91(36.4)	71(18.5)	70(16.8)	141(17.6)
Corneal opacity (CO)	0(0.0)	0(0.0)	0(0.0)	0(0.0)	0(0.0)	0(0.0)	2(1.8)	10(7.1)	12(4.8)	2(0.5)	10(2.4)	12(1.5)
Trachoma, total	78(39.8)	80(39.2)	158(39.5)	23(29.9)	32(43.8)	55(36.7)	59(53.6)	65(46.4)	124(49.6)	160(41.8)	177(42.4)	337(42.1)
Examined (denominators)	196	204	400	77	73	150	110	140	250	383	417	800