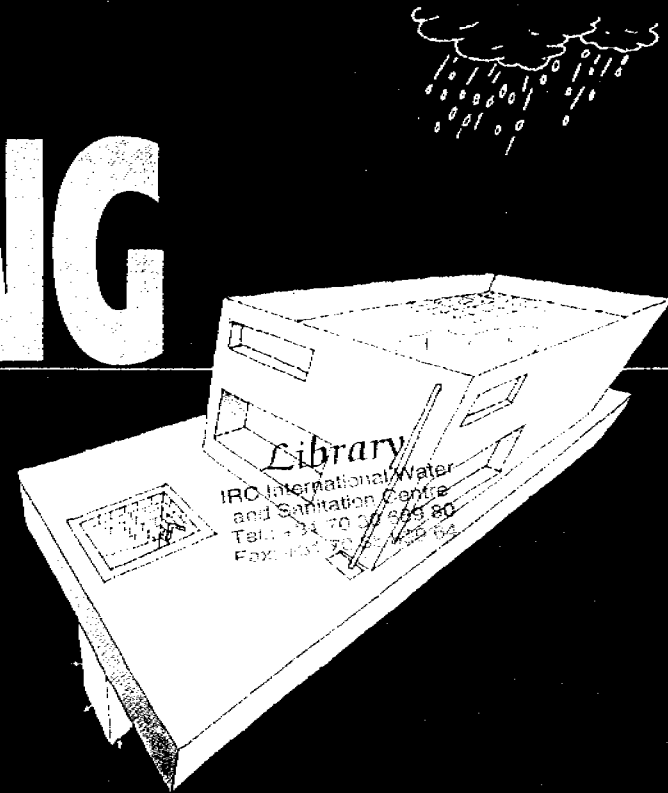
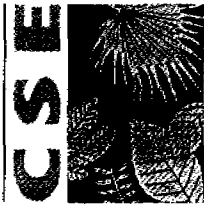


# A WATER HARVESTING MANUAL

for urban areas  
Case Studies From Delhi





The Centre for Science and Environment is a public interest research and advocacy organisation, which promotes environmentally-sound and equitable development strategies. The Centre's work over the past 17 years has led it to believe and argue, both nationally and internationally, that participation, equity and community-based natural resource management systems alone will lead the nations of the world towards a durable peace and development.

As a public interest organisation, the Centre supports and organises information flow in a way that the better organised sections of the world get to hear the problems and perspectives of the less organised. Environmental issues are seen in an anthropocentric perspective that seeks to bring about changes in the behaviour of human societies through appropriate governance systems, human-nature interactions,

and the use of science and technology.

Though the public awareness programmes of the Centre have been its key strength and focus of work, it has endeavoured to move into associated areas of work like policy research and advocacy in the past years. Learning from the people and from the innovations of the committed has helped the Centre to spread the message regarding environment without its normal association with doom and gloom. Rather, the effort of the Centre is to constantly search for people-based solutions and create a climate of hope.

The Centre has always been, and will continue to be, editorially independent of interest groups, governments, political parties, international agencies and funding sources. CSE never accepts funding to push a donor's viewpoint. All its outputs are available for public dissemination.

# A WATER HARVESTING MANUAL

for urban areas  
Case Studies From Delhi

CENTRE FOR SCIENCE AND ENVIRONMENT

LIBRARY IRC  
Box 93190, 2509 AD THE HAGUE  
Tel: +31 70 30 689 80  
Fax: +31 70 35 899 64  
BARCODE: 16942  
LO: 213.1 00WA

© 2000 Centre for Science and Environment

© 2001 Reprint

Material from this publication can be used, but only with proper acknowledgement.

**Project guidance & support:** Anil Agarwal, Sunita Narain

**Project coordinator:** Indira Khurana

**Text and research:** Rahul Ranade

**Technical advice:** R N Athavale, Indukant Ragade, Ashok Khurana

**Design:** Suparna Das

**Illustrations:** Pankaj Khanna, Rahul Ranade

**Production:** Arokia Raj, Kirpal Singh

We are grateful to UNICEF and the Ford Foundation for their support to the Centre's programme on water management.

We are also grateful to the Evangelische Zentralstelle für Entwicklungshilfe E V (EZE) and the Swedish International Development Agency (SIDA) for programme and institutional support.

**Published by:**

**Centre for Science and Environment**

41, Tughlakabad Institutional Area, New Delhi 110062

Tel: 6081110, 6081124, 6083394, 6086399 Fax: 91-11-6085879

Email: [cse@cseindia.org](mailto:cse@cseindia.org) Website: [www.cseindia.org](http://www.cseindia.org)

**Printed at:** multicolourservices, New Delhi

# CONTENTS

Introduction.....	iv
<b>CHAPTER 1</b>	
<b>The urban water crisis</b> .....	1
The water crisis in Delhi.....	1
Unsustainable groundwater use.....	1
<b>CHAPTER 2</b>	
<b>The concept of water harvesting</b> .....	3
Definition of water harvesting.....	3
Need for water harvesting.....	3
How much water can be harvested?.....	4
The case of Delhi.....	
<b>CHAPTER 3</b>	
<b>How to harvest rainwater</b> .....	5
Elements of a typical water harvesting system.....	5
Methods of harvesting water.....	7
PART 1: Storing rainwater for direct use.....	7
PART 2: Recharging groundwater aquifers.....	10
Special precautions.....	17
Cost of water harvesting.....	17
Scale of water harvesting.....	17
<b>CHAPTER 4</b>	
<b>Case Studies</b> .....	19
1. Centre for Science and Environment, New Delhi.....	19
2. Rashtrapati Bhavan, New Delhi.....	21
3. Residence at Vasant Vihar, New Delhi.....	23
4. Institute of Economic Growth, New Delhi.....	24
5. Gapps Industries, Gurgaon.....	27
6. The Sri Ram School, New Delhi.....	29
<b>Frequently Asked Questions</b> .....	32
<b>Glossary of terms</b> .....	34
<b>References</b> .....	35

## INTRODUCTION

The Centre for Science and Environment (CSE) has been involved in raising awareness about the need of community-based water management for a number of years. Unless people are involved from individual households, farmers and industrialists to urban and rural communities – we feel that it will be very difficult to meet the looming water crisis. A water crisis that has come about because rain, as a source of water has been ignored. The potential of rain to meet water demands is tremendous. Theoretically, the average rainfall of 100 mm of rain falling on one hectare of land in arid regions like Jaisalmer can yield up to one million litres of water.

As a technological solution CSE is therefore promoting the concept of community and household-based water harvesting as this decentralised technology can be adopted by all concerned and also promote a participatory paradigm of water management.

Our efforts include the publication of the widely acclaimed book on traditional water harvesting systems, *Dying Wisdom: Rise, Fall and Potential of India's Traditional Water Harvesting Systems*, released in 1997. In October 1998, we had an international conference on Potential of water harvesting: traditions, policies and social mobilisation. One of the outcomes of this has been the establishment of a National Water Harvesters' Network to bring the like-minded together.

An indicator of the success of our campaign has been the requests that we have been deluged with regarding implementation of water harvesting in urban areas. What is more encouraging to us is the fact that people are now concerned about water management and availability and are willing to play an active role in managing water and meeting their demands. To reach a wider audience, we decided to publish a series a manuals on water harvesting as well as conduct training workshops.

This manual has been compiled with the objective of presenting the basics required for undertaking water harvesting. The manual is made in a simple form so that it can be used even by ordinary householders, apart from architects, engineers and other professionals interested in implementing water harvesting.

Apart from various methods and techniques for water harvesting, a few case studies of water harvesting systems designed by CSE in Delhi have been cited so that establishments with similar conditions can take up water harvesting on the same lines. This manual presents methods suitable mainly for singular building/establishment level – residences, institutions and industries. The scope of water harvesting can be extended to a locality/community level by incorporating various such singular units into a group.

As one will gather through the manual, broadly there are two approaches to harvesting water – storing of water for direct use or recharging of groundwater. Since recharging of groundwater is more feasible for the climatic condition of Delhi, more attention has been paid to the groundwater recharging aspects of water harvesting.

This manual is by no means comprehensive, since there are no limits to innovation in techniques that can be applied. The manual is seen as just a beginning; we plan to update it over time corresponding to the development and fine-tuning of the existing methods of water harvesting.

We welcome comments, additions and corrections to be included in future editions.

Anil Agarwal

# CHAPTER 1

## THE URBAN WATER CRISIS

India has more than 250 million city-dwellers even though the rate of urbanization is among the lowest in the world. The percentage of urban dwellers in India keeps increasing - from 10.8 per cent in 1901 to 17.3 per cent in 1951 and 25.7 per cent in 1991. Rural-urban migration and high demographic natural increase in cities will further increase the proportion to more than 50 per cent of the total population by 2020<sup>1</sup>.

Mumbai, Calcutta and Delhi already have more than 10 million inhabitants while more than 23 Indian cities have a population above a million. In most of these cities, the water supply sector is faced with a number of problems and constraints. Freshwater sources are being heavily exploited to meet the demands of the urban populace.

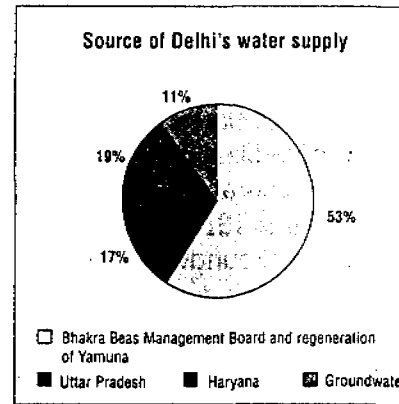
As surface water sources fail to meet rising demands, groundwater reserves are tapped, often to unsustainable levels. Almost all cities depending on groundwater are faced with the rapid depletion of their water tables. In Ahmedabad, the water table has gone down by more than 90 m since 1965<sup>2</sup>.

In addition to quantity, the country also faces problems of water quality. Overextraction of groundwater in Chennai has led to salinity intrusion in the coastal aquifers. Chennai had to bring water from the surrounding rural areas, leading to rural-urban conflicts.

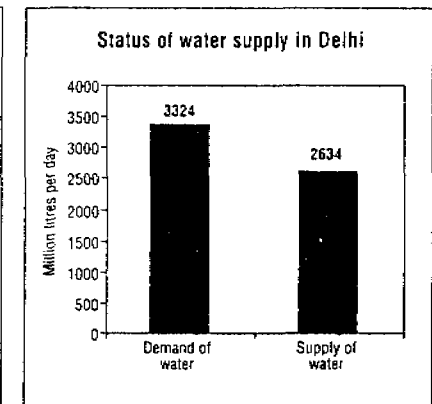
### The water crisis in Delhi

The city of Delhi is almost perpetually in the grip of a water crisis, more so during the dry season when serious water shortages afflict the city. A large number of residents depend on groundwater to augment the municipal supply. Delhi has no right over the Yamuna and is supplied by surface water from the Yamuna and the dam on river Beas from its neighbouring states (see graph 1.1).

The population of Delhi, according to the 1991 census, was 9.42 million, which is expected to cross 14 million by 2001. Against the present requirement of about 3324 million litres/day (MLD), the installed capacity is only 2634 MLD (see graph 1.2)<sup>3</sup>.



**Graph 1.1** Sources of Delhi's water supply **Graph 1.2** Gap in demand and supply of water in Delhi



Although the average water consumption in Delhi is estimated at 240 litres per capita per day (lpcd), the highest in India, the figure is not indicative of an adequate supply to every resident since the water supply in Delhi is far from being uniformly distributed. The New Delhi Municipal Corporation (NDMC) and Delhi Cantonment areas get an average supply of above 450 lpcd, while areas in Narela and Mehrauli zones get less than 35 lpcd<sup>4</sup>.

The gap between the supply and demand of water has resulted in large-scale development (read, over-extraction) of groundwater. This has led to serious problems with both quantity and quality of groundwater.

### Unsustainable groundwater use

Delhi-ites are a major groundwater-dependent community. Of the water supplied by the municipality, approximately 11 per cent comes from groundwater reserves. However, it is difficult to establish the total quantity of groundwater extracted, because a large number of private tubewells dug by households and the

industrial sector for their own supply are unaccounted for in the official figures. Many water tanker and bottled water companies are drawing and selling groundwater.

Unplanned and uncontrolled extraction of groundwater has disturbed the hydrological balance, leading to decline in productivity of wells, rise in energy requirement and deterioration in quality of water.

There has been a widespread drop in the groundwater table in Delhi, especially in the south and southwestern localities of Delhi.

The water table has depleted by 2 to 8 m in the past decade<sup>5</sup>. The lack of regulation related to private or individual extraction of groundwater aggravates this situation. In addition to overexploitation of groundwater, the uncontrolled disposal of effluents and sewage in the city has contaminated the groundwater to alarming levels. Studies conducted by Central Ground Water Board in Delhi revealed that groundwater in most parts of Delhi is contaminated with fluoride and nitrate and is unfit for drinking without treatment.

## UNDERSTANDING GROUNDWATER

Contrary to popular belief, groundwater reserves are not in the form of lakes or streams of water inside the ground. Water in the ground is stored in the interstices (inter-particulate spaces) of the soil or rock that forms the earth. It is similar to water being stored in a sponge – it is not visible, but can be 'squeezed' out (or drawn out). A simple experiment to understand the nature of the groundwater is illustrated below.

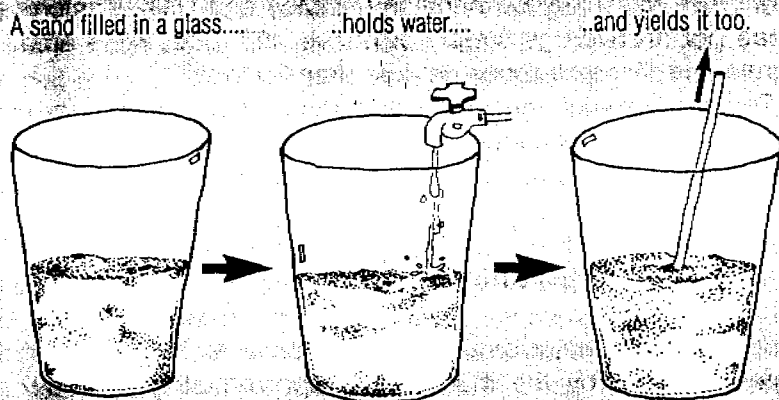


Figure 1.1 Understanding groundwater

The soil or rock formations in the earth that contain water are called groundwater aquifers. Below a certain depth in the ground, the earth is saturated (saturation is a state in which all the free spaces or interstices are filled with water). This level is referred to as the groundwater level. This level may be just below the ground level or many hundred metres below ground level. In the Delhi area, groundwater levels vary between 3 to 60 metres below ground level.

## How is groundwater formed?

When rain falls on the surface of the earth, some amount of water percolates through the soil and moves downwards under the effect of gravity. When water moves through the soil, it is said to be infiltrating, because it gets filtered in the process of passing through the pores of the soil. Groundwater aquifers are formed over many years, as infiltration from successive rains joins the existing groundwater.

## What is groundwater depletion?

Heavy extraction of groundwater leads to an imbalance in the groundwater reserves as the withdrawal of water is more than the recharge. This leads to depletion of the groundwater resources. Depth to water table from the surface increases and wells become dry.



# CHAPTER 2

## THE CONCEPT OF WATER HARVESTING

### Definition of water harvesting

In scientific terms, water harvesting refers to collection and storage of rainwater and also other activities aimed at harvesting surface and groundwater, prevention of losses through evaporation and seepage and all other hydrological studies and engineering interventions, aimed at conservation and efficient utilization of the limited water endowment of physiographic unit such as a watershed.

In general, water harvesting is the activity of direct collection of rainwater. The rainwater collected can be stored for direct use or can be recharged into the groundwater.

Rain is the first form of water that we know in the hydrological cycle, hence is a primary source of water for us (see figure 2.1).

Rivers, lakes and groundwater are all secondary sources of water. In present times, we depend entirely on such secondary

sources of water. In the process, it is forgotten that rain is the ultimate source that feeds all these secondary sources and remain ignorant of its value. Water harvesting means to understand the value of rain, and to make optimum use of rainwater at the place where it falls.

### Need for water harvesting

We get a lot of rain, yet we do not have water. Why? Because we have not reflected enough on the value of the raindrop. The annual rainfall over India is computed to be 1,170 mm (46 inches). This is higher compared to the global average of 800 mm (32 inches)<sup>6</sup>. However, this rainfall occurs during short spells of high intensity. Because of such intensities and short duration of heavy rain, most of the rain falling on the surface tends to flow away rapidly, leaving very little for the recharge of groundwater. This makes most parts of India experience lack of water even for domestic uses.

Ironically, even Cherrapunji which receives about 11,000 mm of rainfall annually suffers from acute shortage of drinking water. This is because the rainwater is not conserved and allowed to drain away. Thus it does not matter how much rain we get, if we don't capture or harvest it.

This highlights the need to implement measures to ensure that the rain falling over a region is tapped as fully as possible through water harvesting, either by recharging it into the groundwater aquifers or storing it for direct use.

### How much water can be harvested?

The total amount of water that is received in the form of rainfall over an area is called the *rainwater endowment* of that area. Out of this, the amount that can be effectively harvested is called the *water harvesting potential*.

Water harvesting potential = Rainfall (mm) x Collection efficiency

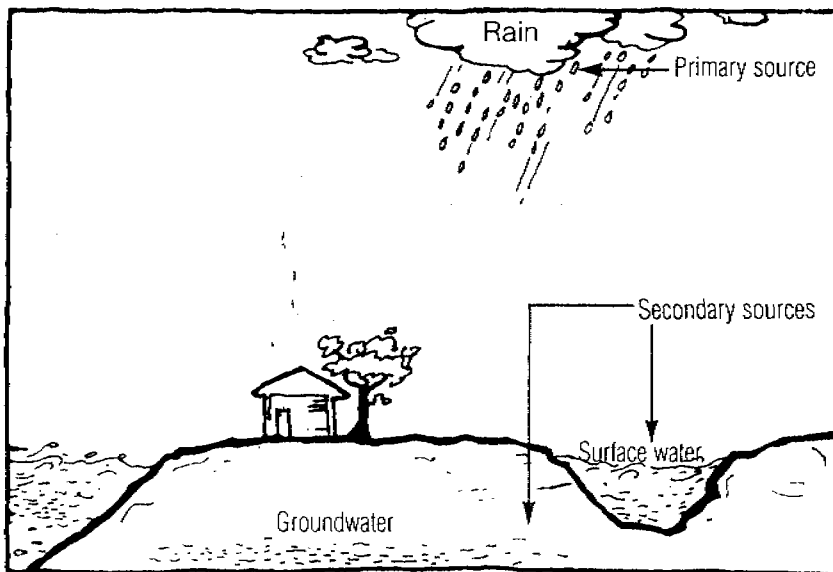


Figure 2.1 Where does all our water come from?

The *collection efficiency* accounts for the fact that all the rainwater falling over an area cannot be effectively harvested, because of evaporation, spillage etc. Factors like runoff coefficient (see box: Runoff coefficient on p10) and the first-flush wastage (see box: First-flush device on p9) are taken into account when estimating the collection efficiency.

The following is an illustrative theoretical calculation that highlights the enormous potential for rainwater harvesting. The same procedure can be applied to get the potential for any plot of land or rooftop area, using rainfall data for that area.

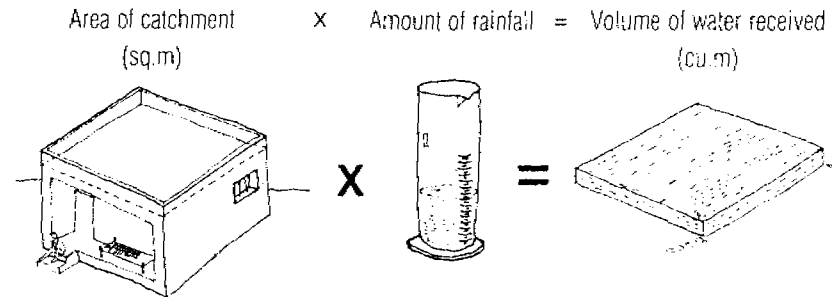
Consider a building with a flat terrace area of 100 sq. m. The average annual rainfall in Delhi is approximately 600 mm (24 inches). In simple terms, this means that if the terrace floor is assumed to be impermeable, and all the rain that falls on it is retained without evaporation, then, in one year, there will be rainwater on the terrace floor to a height of 600 mm.

Area of plot	= 100 sq. m. (120 sq. yd.)
Height of rainfall	= 0.6 m (600 mm or 24 inches)
Volume of rainfall over the plot	= Area of plot x Height of rainfall
	= 100 sq. m. x 0.6 m
	= 60 cu. m. (60,000 litres)

Assuming that only 60% of the total rainfall is effectively harvested,

Volume of water harvested	= 36,000 litres (60,000 litres x 0.6)
---------------------------	---------------------------------------

This volume is about twice the annual drinking water requirement of a 5-member family. The average daily drinking water requirement per person is 10 litres<sup>7</sup>.



**Figure 2.2** How much water do we get in the form of rain?

### The case of Delhi

Delhi has an annual average rainfall of 611.8 mm. However, recharge to groundwater is limited because of decreasing availability of permeable soil surfaces due to the existence of roads and buildings.

As a result of poor recharge and heavy extraction of groundwater, groundwater levels in Delhi have declined by as much as 8 metres in the past decade. Groundwater can be a sustainable source of water only if it is ensured that the amount of water withdrawn from the groundwater aquifers is compensated by recharging an equal amount of rainwater into the ground. Water harvesting provides the means to recharge the groundwater, thereby maintain the balanced situation of the resource.

Rainwater harvesting has a huge potential in Delhi. The illustrative calculation for water harvesting potential for a single building, can also be applied to the city as a whole. With an area of 1,486 sq. km., the rainwater harvesting potential of Delhi comes to be about 907 billion litres annually. This is equal to about 270 days of water requirement for the entire city.

The entire annual rainfall is received over a period of 27 days, 80 per cent of which falls in the period between July to September. The rainwater therefore has to be harvested during this short period.

# CHAPTER 3

## HOW TO HARVEST RAINWATER

Broadly, rainwater can be harvested for two purposes:

- RAINWATER → Stored for ready use in containers above ground or below ground
- RAINWATER → Charged into soil for withdrawal later (groundwater recharging)

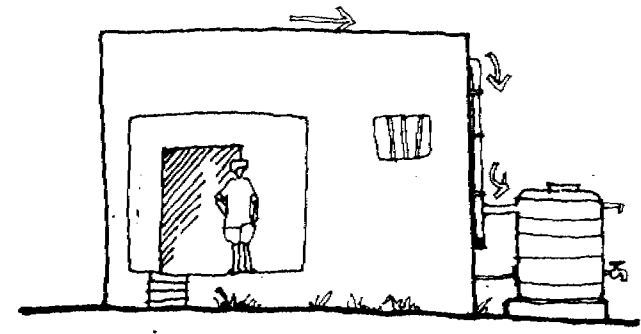


Figure 3.1 Rainwater can be stored in tanks

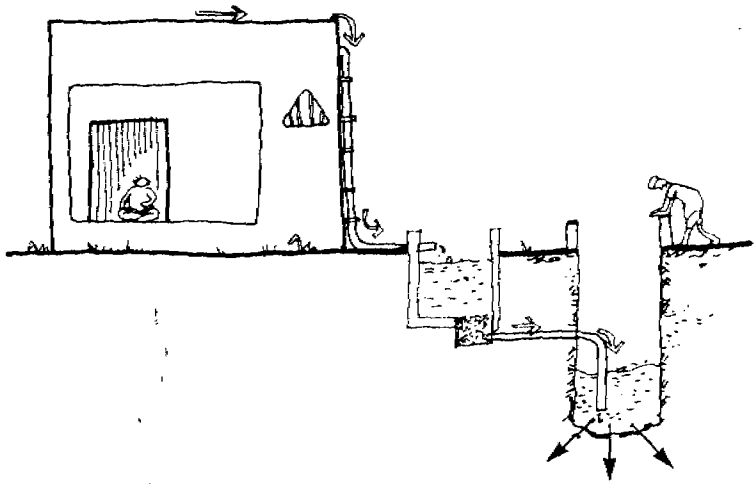


Figure 3.2 Rainwater can be recharged into the ground

## Elements of a typical water harvesting system

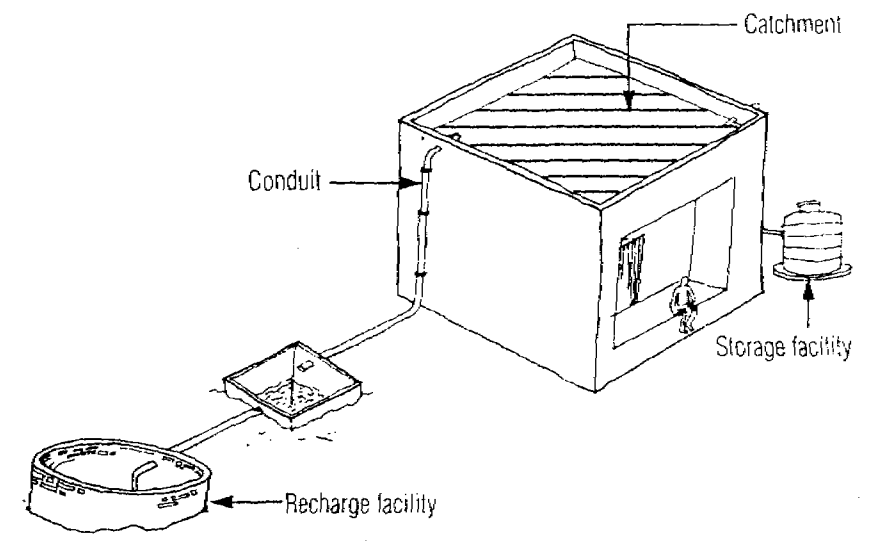


Figure 3.3 Elements of typical water harvesting system

### 1. Catchments

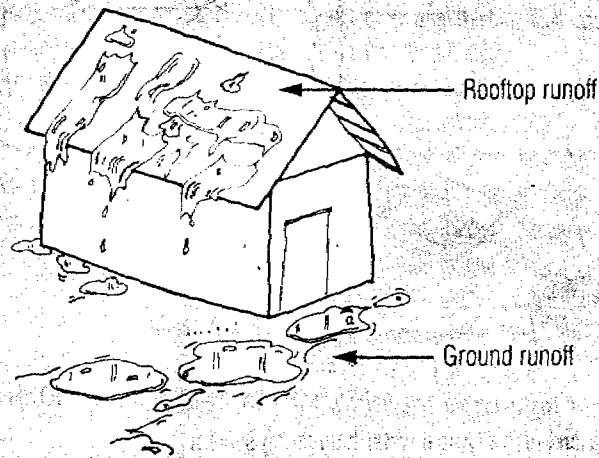
The catchment of a water harvesting system is the surface which receives rainfall directly and contributes the water to the system. It can be a paved area like a terrace or courtyard of a building, or an unpaved area like a lawn or open ground. Temporary structures like sloping sheds can also act as catchments.

### 2. Conduits

Conduits are the pipelines or drains that carry rainwater from the catchment or rooftop to the harvesting system. Conduits may be of any material like polyvinylchloride (PVC), asbestos or galvanized iron (GI), materials that are commonly available.

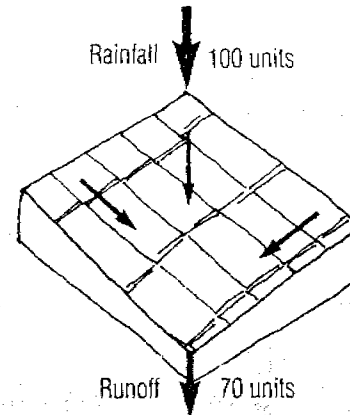
## RUNOFF

Runoff is the term applied to the water that flows away from a catchment after falling on its surface in the form of rain. Runoff can be generated from both paved and unpaved catchment areas of buildings.

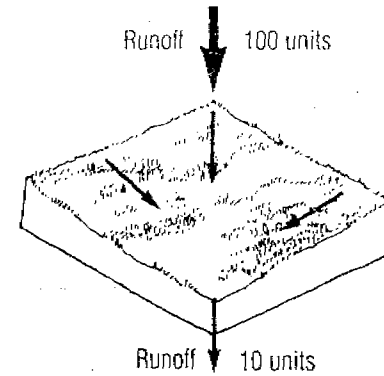


**Figure 3.4** Runoff from a surface

The nature of the catchment determines the quantity of runoff that occurs from the area. For example, about 70 per cent of the rainfall that occurs over



**Figure 3.5** Runoff from a smooth tiled surface



**Figure 3.6** Runoff from a surface covered with grass

the tiled surface of a terrace would flow as runoff while only 10 per cent of the rainfall on a wooded or grassy area would flow, the rest being retained on the surface and getting percolated into the ground.

From the point of view of quality, runoff can be divided into two types: runoff from paved surfaces (e.g., roofs and courtyards) and runoff from unpaved surfaces (e.g., lawns and playgrounds). Quality of runoff from paved surfaces is better since runoff from unpaved surfaces may have bacterial or other contamination. If water is to be stored for drinking purposes, it is advisable that only runoff from paved surfaces is used for the purpose.

### 3a. Storage facility

Rainwater can be stored in any commonly used storage containers like RCC, masonry or plastic water tanks. Some maintenance measures like cleaning and disinfection are required to ensure the quality of water stored in the container.

### 3b. Recharge facility

Alternative to storing, rainwater may be charged into the groundwater aquifers. This can be done through any suitable structures like dugwells, borewells, recharge trenches and recharge pits.

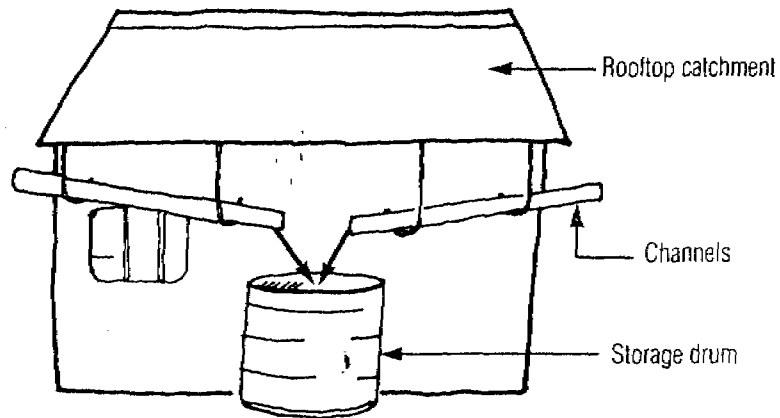
## Methods of harvesting water

As illustrated on p5, there are two broad approaches to harvesting water:

1. Storing rainwater for direct use
2. Recharging groundwater aquifers

### PART 1: Storing rainwater for direct use

Rooftop harvesting has been practiced since ages, and even today it is practiced in many places throughout the world. In some cases, the rooftop harvesting system is little more a split pipe or bamboo directing runoff from the roof into an old oil drum placed near the roof (see figure 3.7).

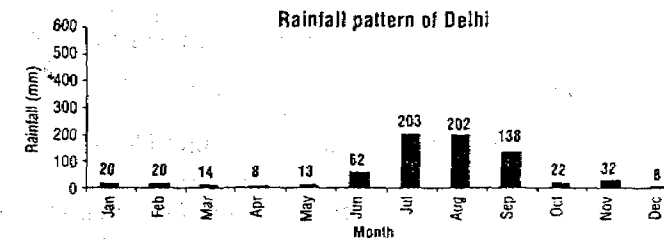
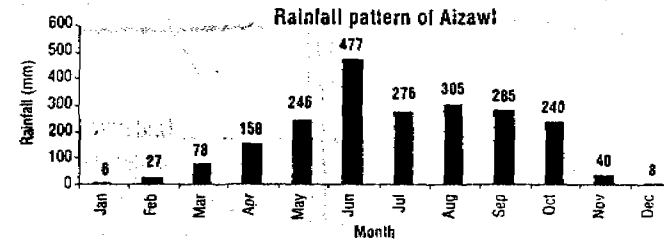


**Figure 3.7** A simple water harvesting system

In Ahmedabad, which has a climate similar to that of Delhi, traditional rainwater harvesting tanks which store drinking water can be seen even today in some old houses (see figure 3.8 on p8).

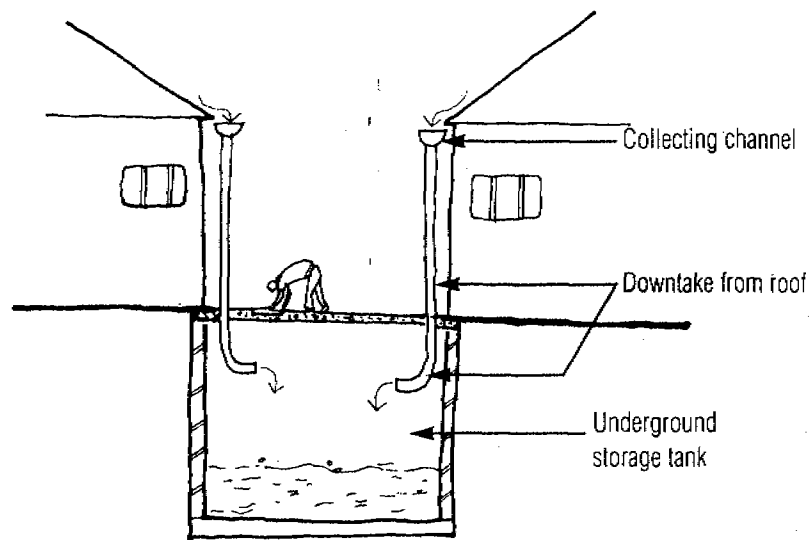
## SHOULD WATER BE STORED OR SHOULD IT BE RECHARGED?

The decision whether to store or recharge water depends on the rainfall pattern of a particular region. For example, in places like Kerala and Mizoram, rain falls throughout the year, barring a few dry periods. In such places, one can depend on a small domestic-sized water tank for storing rainwater, since the period between two spells of rain is short.



**Graph 3.1** Comparison between rainfall pattern of Aizawl and Delhi

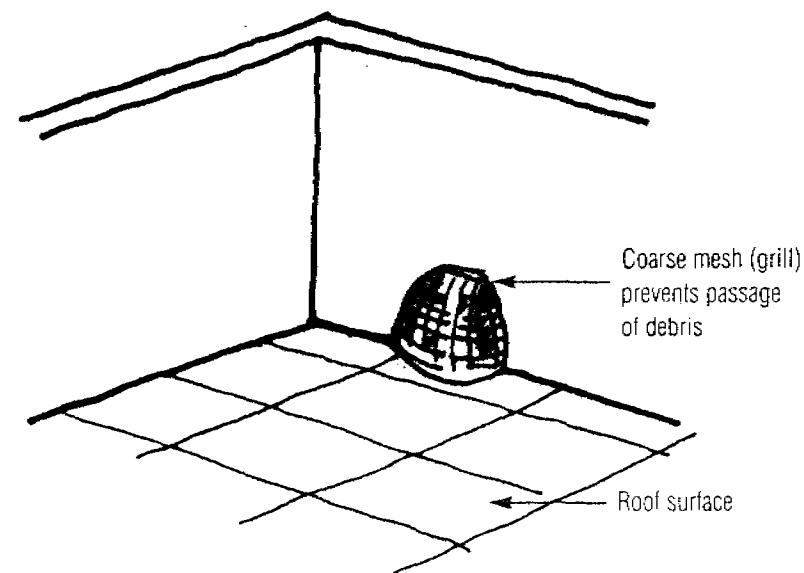
On the other hand, in dry areas like Delhi, Rajasthan and Gujarat, the total annual rainfall occurs only during 3 or 4 months of monsoon. The water collected during the monsoon has to be stored throughout the year; which means that huge volumes of storage containers would have to be provided. In Delhi, it is more feasible to use rainwater to recharge groundwater aquifers rather than for storage.



**Figure 3.8** Rainwater can be stored in underground tanks as in this traditional rainwater harvesting system in Ahmedabad

Generally, runoff from only paved surfaces is used for storing, since it is relatively free of bacteriological contamination. Drainpipes that collect water from the catchment (rooftop) are diverted to the storage container. Figure 3.1 on shows a typical water harvesting system.

To prevent leaves and debris from entering the system, mesh filters should be provided at the mouth of the drain pipe (see figure 3.9). Further, a first-flush device (see box: First flush devices on p9) should be provided in the conduit before it connects to the storage container. If the stored water is to be used for drinking purposes, a sand filter should also be provided (see box: Disinfecting water at domestic level on p11)



**Figure 3.9** A grill prevents debris from entering the drainpipe

An underground RCC/masonry tank can be used for storage of the rainwater. The tank can be installed inside the basement of a building (see figure 3.8) or outside the building. Pre-fabricated tanks such as PVC can be installed above the ground.

Each tank must have an overflow system for situations when excess water enters the tank. The overflow can be connected to the drainage system.

### Design of storage tank

The quantity of water stored in a water harvesting system depends on the size of the catchment area and the size of the storage tank. The storage tank has to be designed according to the water requirements, rainfall and catchment availability.

## RUNOFF COEFFICIENT

Runoff coefficient is the factor which accounts for the fact that all the rainfall falling on a catchment cannot be collected. Some rainfall will be lost from the catchment by evaporation and retention on the surface itself.

**Table 3.1 Runoff coefficients for various surfaces**

Type of Catchment	Coefficients
Roof Catchments	
- Tiles	0.8 - 0.9
- Corrugated metal sheets	0.7 - 0.9
Ground surface coverings	
- Concrete	0.6 - 0.8
- Brick pavement	0.5 - 0.6
Untreated ground catchments	
- Soil on slopes less than 10 per cent	0.0 - 0.3
- Rocky natural catchments	0.2 - 0.5

Source: Pacey, Arnold and Cullis, Adrian 1989, *Rainwater Harvesting: The collection of rainfall and runoff in rural areas*, Intermediate Technology Publications, London, pg. 55

## Quality of stored water

Rainwater collected from rooftops is free of mineral pollutants like fluoride and calcium salts which are generally found in groundwater. But, it is likely to be contaminated with these types of pollutants:

1. Air pollutants
2. Surface contamination (e.g., silt, dust)

## Measures to ensure water quality

All these types of contaminations can be prevented to a large extent by ensuring that the runoff from the first 10-20 minutes of rainfall is flushed off.

Most of the debris carried by the water from the rooftop like leaves, plastic bags and paper pieces is arrested by the grill at the terrace outlet for rainwater. Remaining contaminants like silt and blow dirt can be removed by sedimentation (settlement) and filtration (see box: Disinfecting water at a household level on p12).

Contrary to popular belief, water quality improves over time during storage in the tank because impurities settle in the tank if the water is not disturbed. Even pathogenic (harmful) organisms gradually die out due to storage.

Additionally, biological contamination can be removed by disinfecting the water. Many simple methods of disinfection are available which can be done at a domestic level (see box: Disinfecting water at a household level on p11).

Specifications for drinking water are given by IS: 10500 and World Health Organisation (WHO).

## PART 2: Recharging groundwater aquifers

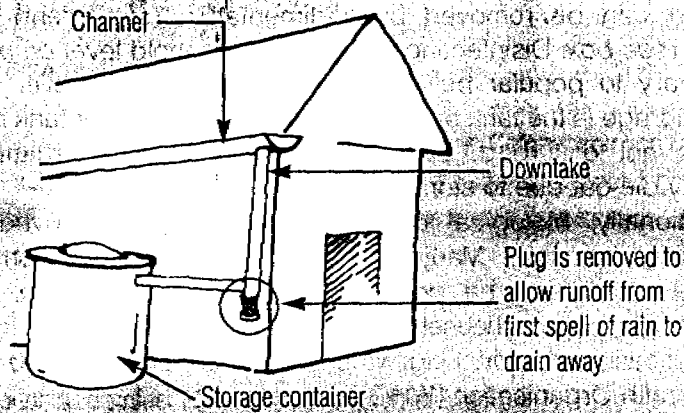
Various kinds of recharge structures are possible which can ensure that rainwater percolates in the ground instead of draining away from the surface. While some structures promote the percolation of water through soil strata at shallower depth (e.g., recharge trenches, permeable pavements), others conduct water to greater depths from where it joins the groundwater (e.g., recharge wells).

At many locations, existing features like wells, pits and tanks can be modified to be used as recharge structures, eliminating the need to construct any structures afresh.

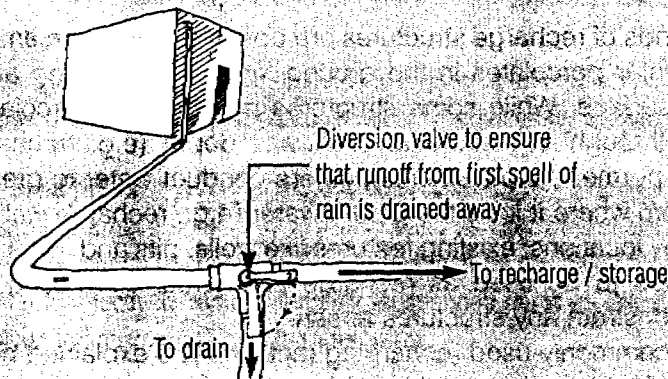
A few commonly-used recharging methods are explained here. Innumerable innovations and combinations of these methods are possible.

## FIRST-FLUSH DEVICE

A first-flush device is a valve or a simple device which is used to ensure that runoff from the first spell of rain is flushed out and does not enter the system. This needs to be done since the first spell of rain carries with it a relatively larger amount of pollutants from the air and catchment surface.



**Figure 3.10** A simple first-flush device, used traditionally



**Figure 3.11** A diversion valve that can be used in water harvesting systems

Design parameters for storage tanks:

1. Average annual rainfall
2. Size of the catchment
3. Drinking water requirement

Suppose the system has to be designed for meeting drinking water requirement of a 5-member family living in a building with a rooftop area of 100 sq. m. Average annual rainfall in the region is 600 mm (average annual rainfall in Delhi is 611 mm). Daily drinking water requirement per person (drinking and cooking) is 10 litres.

We shall first calculate the maximum amount of rainfall that can be harvested from the rooftop:

Following details are available:

Area of the catchment (A) = 100 sq. m.

Average annual rainfall (R) = 611 mm (0.61 m)

Runoff coefficient (C) = 0.85

$$\begin{aligned} \text{Annual water harvesting potential from 100 sq. m. roof} \\ &= A \times R \times C \\ &= 100 \times 0.6 \times 0.85 \\ &= 51 \text{ cu. m. (51,000 litres)} \end{aligned}$$

The tank capacity has to be designed for the dry period, i.e., the period between the two consecutive rainy seasons. With a monsoon extending over four months, the dry season is of 245 days.

$$\begin{aligned} \text{Drinking water requirement for the family (dry season)} \\ &= 245 \times 5 \times 10 \\ &= 12,250 \text{ litres} \end{aligned}$$

As a safety factor, the tank should be built 20 per cent larger than required, i.e., 14,700 litres. This tank can meet the basic drinking water requirement of a 5-member family for the dry period.



## DISINFECTING WATER AT A HOUSEHOLD LEVEL

### Boiling

Boiling is a very effective method of purification and very simple to carry out. Boiling water for 10 to 20 minutes is enough to remove all biological contaminants.

### Chemical Disinfection

#### a. Chlorination

Chlorination is done with stabilised bleaching powder (calcium hypochlorite -  $\text{CaOCl}_2$ ) which is a mixture of chlorine and lime. Chlorination can kill all types of bacteria and make water safe for drinking purposes. About 1 gm (approximately 1/4 tea spoon) of bleaching powder is sufficient to treat 200 litres of water.

#### b. Chlorine tablets

Chlorine tablets are easily available commercially. One tablet of 0.5 g is enough to disinfect 20 litres (a bucketful) of water.

### Filtration

#### a. Charcoal water filter

A simple charcoal filter can be made in a drum or an earthen pot. The filter is made of gravel, sand and charcoal, all of which is easily available.

#### b. Sand filters

Sand filters have commonly available sand as filter media. Sand filters are easy and cheap to construct. These filters can be employed for treatment of water to effectively remove turbidity (suspended particles like silt and clay), colour and microorganisms from the water.

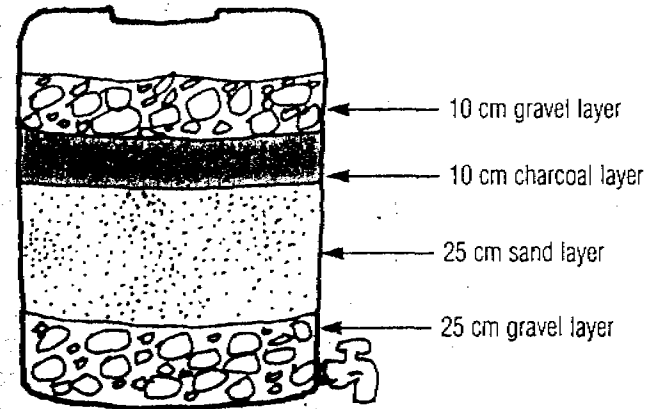


Figure 3.12 Composition of a charcoal filter

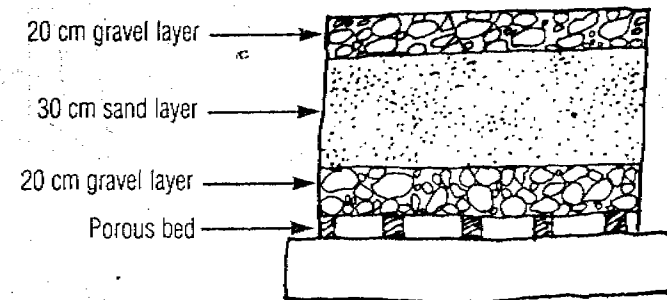


Figure 3.13 A simple sand filter which can be constructed at a domestic level

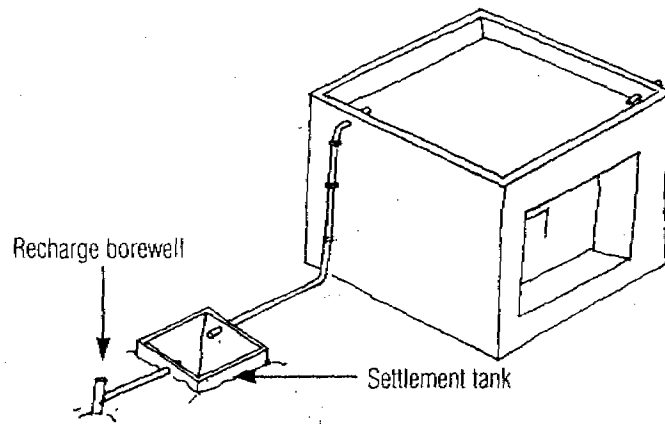
#### c. Ceramic filters

These filters are manufactured commercially on a wide scale. Most of the water purifiers available in the market are of this type.

## 1. Borewells / dugwells

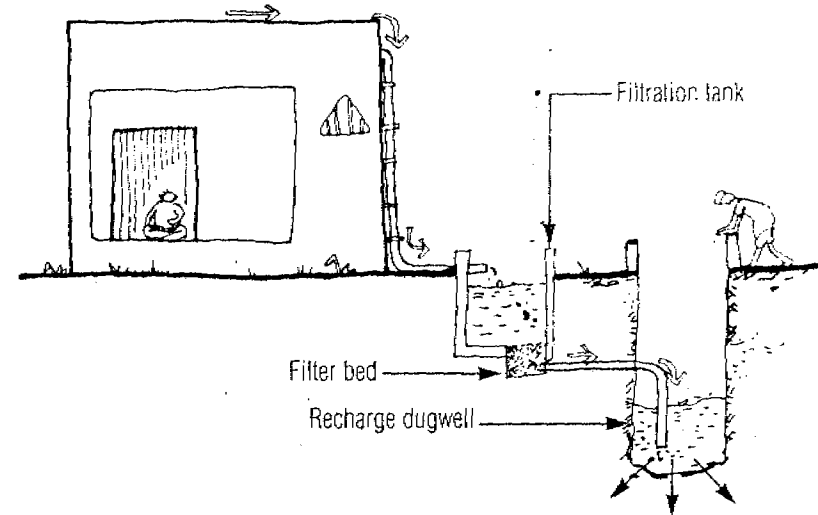
Figures 3.14 and 3.15 show typical systems of recharging wells directly with rooftop runoff. Rainwater that is collected on the rooftop of the building is diverted by drainpipes to a settlement or filtration tank, from which it flows into the recharge well (borewell or dugwell).

If a borewell is used for recharging, then the casing (outer pipe) of the borewell should preferably be a slotted or perforated pipe so that more surface area is available for the water to percolate. Developing a borewell would increase its recharging capacity (*developing* is the process where water or air is forced into the well under pressure to loosen the soil strata surrounding the bore to make it more permeable).



**Figure 3.14** Recharge assembly for borewell.

If a dugwell is used for recharge, the well lining should have openings (weep-holes) at regular intervals to allow seepage of water through the sides. Dugwells should be covered to prevent mosquito breeding and entry of leaves and debris. The bottom of recharge dugwells should be desilted annually to maintain the intake capacity.



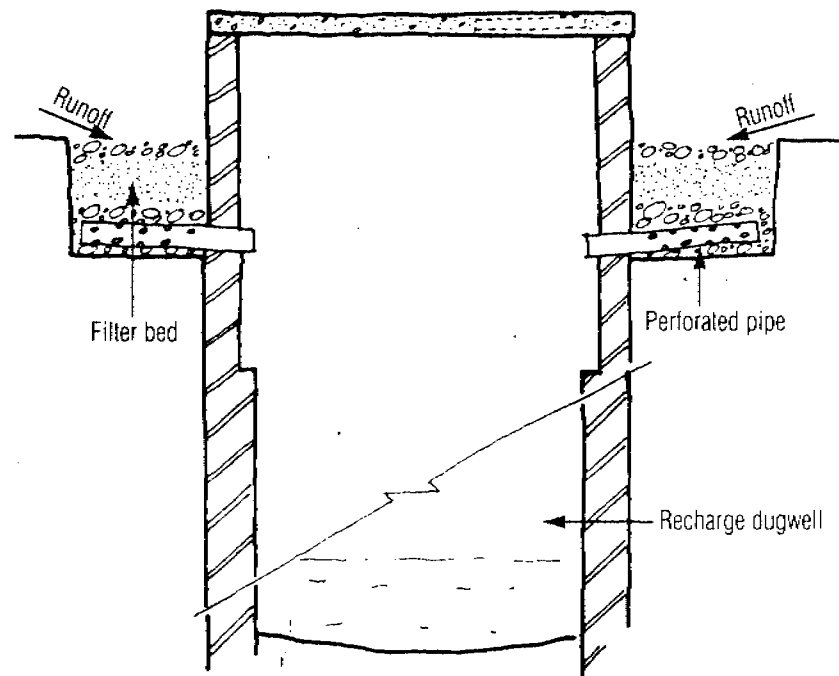
**Figure 3.15** Recharge assembly for dugwell with rooftop runoff

Precautions should be taken to ensure that physical matter in the runoff like silt and floating debris do not enter the well since it may cause clogging of the recharge structure. It is preferred that the dugwell or borewell used for recharging be shallower than the water table (see figure 3.17 on p13). This ensures that the water recharged through the well has a sufficient thickness of soil medium through which it has to pass before it joins the groundwater (see box: Understanding groundwater on p2). Any old well which has become defunct can be used for recharging, since the depth of such wells is above the water level.

### Quality of water recharged

The quality of water entering the recharging wells can be ensured by providing the following elements in the system:

1. Filter mesh at entrance point of rooftop drains
2. Settlement chamber
3. Filter bed



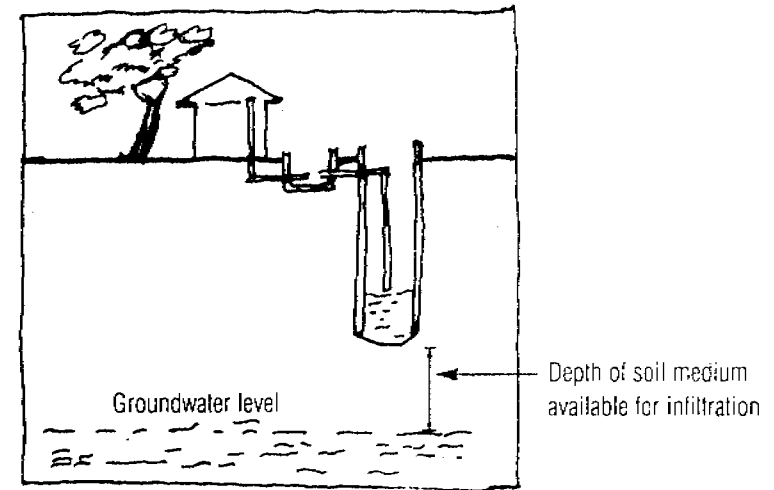
**Figure 3.16** Recharge assembly for dugwell with runoff from ground areas (non-rooftop)

#### Design parameters for settlement tank

For designing the optimum capacity of the tank, following aspects have to be considered:

1. Size of the catchment
2. Intensity of rainfall
3. Rate of recharge

Since the desilting tank also acts as buffer tank, it is designed such that it can retain a certain amount of rainfall, since the rate of recharge may not be comparable with the rate of runoff. The capacity of the tank should be enough to retain the runoff occurring



**Figure 3.17** Recharge wells should preferably be shallower than the water table

from conditions of peak rainfall intensity. In Delhi, peak hourly rainfall is 90 mm (based on 25 year frequency)<sup>8</sup>. The rate of recharge in comparison to runoff is a critical factor. However, since accurate recharge rates are not available without detailed geohydrological studies, the rates have to be assumed. The capacity of recharge tank is designed to retain runoff from at least 15 minutes rainfall of peak intensity (For Delhi, 22.5 mm/hr. say, 25 mm)\*.

Suppose the following data is available:

Area of rooftop catchment (A) = 100 sq. m.  
 Peak rainfall in 15 min (r) = 25 mm (0.025 m)  
 Runoff coefficient (C) = 0.85

Then, capacity of desilting tank =  $A \times r \times C$   
 =  $100 \times 0.025 \times 0.85$   
 = 2.125 cu. m. (2,125 litres)

\*According to CGWB norms

## SETTLEMENT TANK

Settlement tanks are used to remove silt and other floating impurities from rainwater. A settlement tank is like an ordinary storage container having provisions for inflow (bringing water from the catchment), outflow (carrying water to the recharge well) and overflow. A settlement tank can have an unpaved bottom surface to allow standing water to percolate into the soil.

Apart from removing silt from the water, the desilting chamber acts like a buffer in the system. In case of excess rainfall, the rate of recharge, especially of borewells, may not match the rate of rainfall. In such situations, the desilting chamber holds the excess amount of water till it is soaked up by the recharge structure.

### Options for settlement tank

Any container with adequate capacity of storage can be used as a settlement tank. Generally, masonry or concrete underground tanks are preferred since they do not occupy any surface area (see figure 3.18). Old disused tanks can be modified to be used as settlement tanks (see Case Study 3 on p23).

For overground tanks, pre-fabricated PVC or ferrocement tanks can be used. Pre-fabricated tanks are easier to install, compared to masonry and concrete tanks (see figure 3.19).

## 2. Recharge pits

A recharge pit is a pit 1.5 m to 3 m wide and 2 m to 3 m deep. The excavated pit is lined with a brick/stone wall with openings (weep-holes) at regular intervals. The top area of the pit can be covered with a perforated cover (see figure 3.20 on p15).

The method for designing a recharge pit is similar to that for a settlement tank.

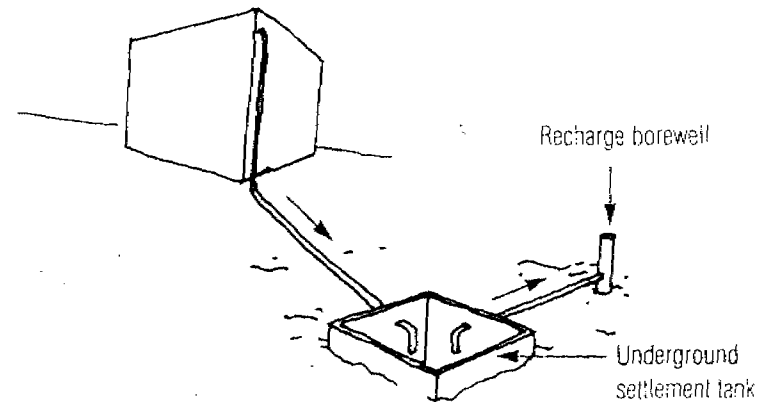


FIGURE 3.18 Underground masonry settlement tank

## 3. Soakaways

A soakaway is a bored hole of up to 30 cm diameter drilled in the ground to a depth of 3 to 10 m. The soakaway can be drilled with a manual auger unless hard rock is found at a shallow depth. The borehole can be left unlined if a stable soil formation like clay is present. In such a case, the soakaway may be filled up with a filter media like brickbats. In unstable formations like sand, the soakaway should be lined with a PVC or MS pipe to prevent collapse of the

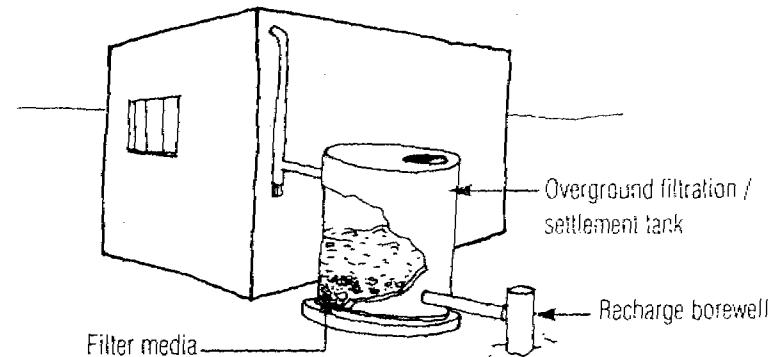
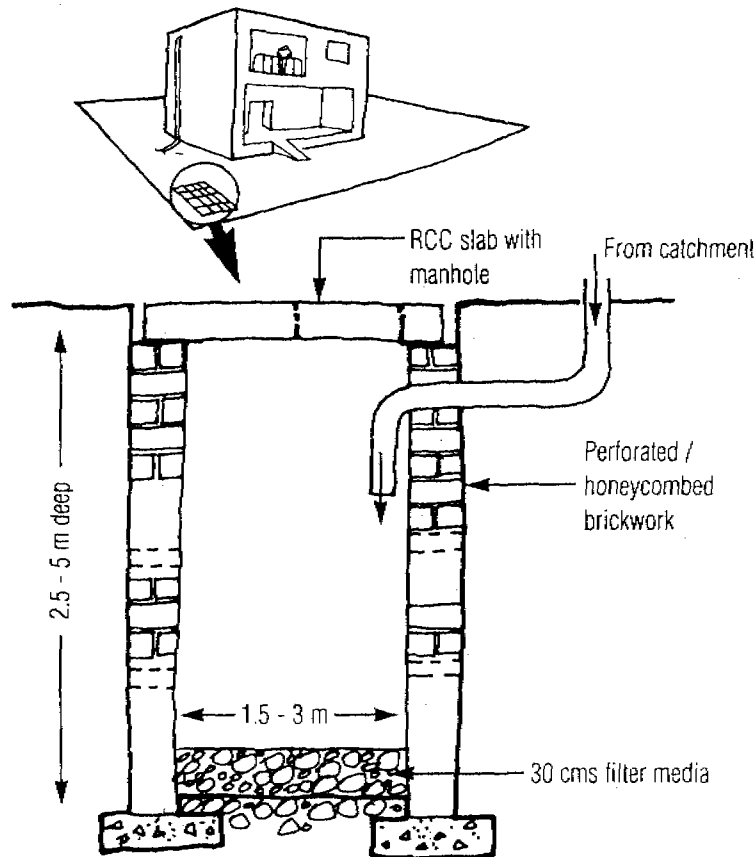


Figure 3.19 Overground PVC settlement tank

vertical sides (see Case Study 1 on p19). The pipe may be slotted/perforated to promote percolation through the sides.

A small sump is built at the top end of the soakaway where some amount of runoff can be retained before it infiltrates through the soakaway. Since the sump also acts like a buffer in the system, it has to be designed on the basis of expected runoff as described for settlement tanks.

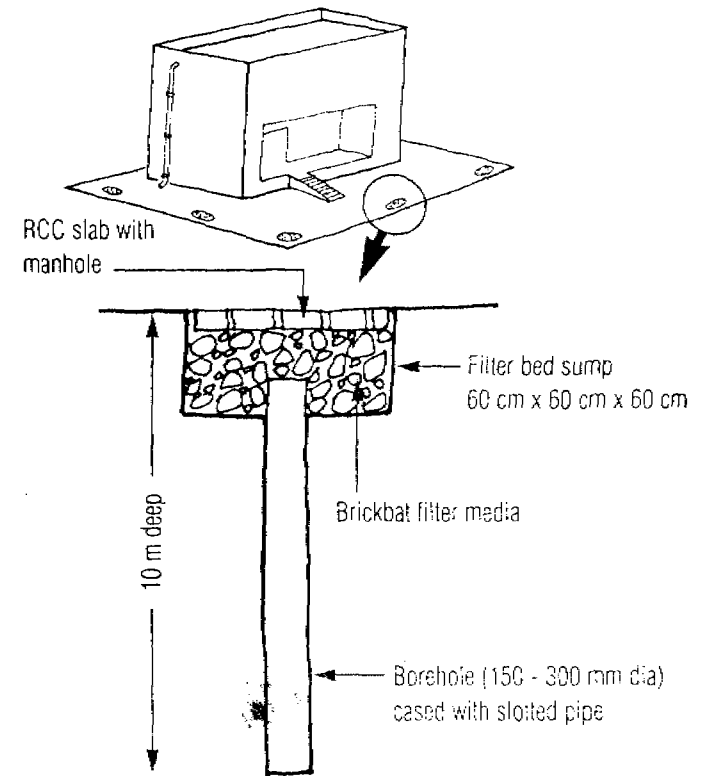


**Figure 3.20** Location of recharge pit in a building area and detailed section of pit

#### 4. Recharge trenches

Recharging through recharge trenches, recharge pits and soakaways is simpler compared to recharge through wells. Fewer precautions have to be taken to maintain the quality of the rainfall runoff. For these type of structures, there is no restriction on the type of catchment from which water is to be harvested, i.e., both paved and unpaved catchments can be tapped.

A recharge trench is simply a continuous trench excavated in the ground and refilled with porous media like pebbles, boulders



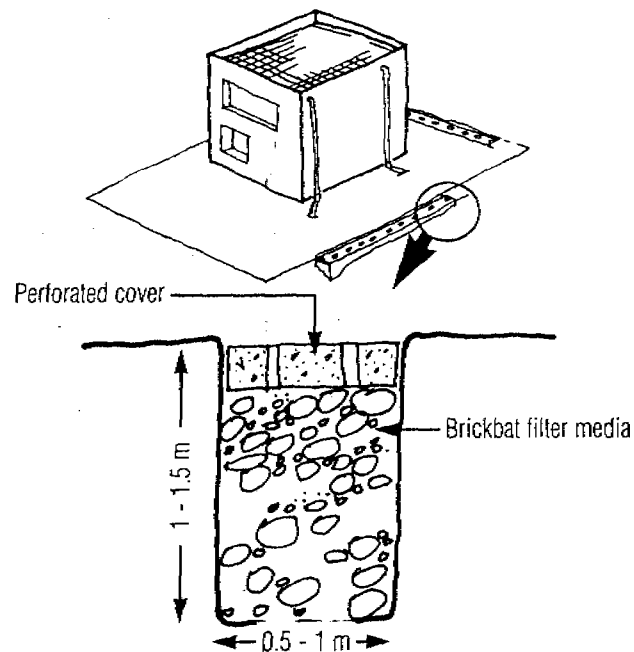
**Figure 3.21** Location of soakaways in a building area with detailed section of soakaway

or brickbats (see figure 3.22). A recharge trench can be 0.5 m to 1 m wide and 1 m to 1.5 m deep. The length of the recharge trench is decided as per the amount of runoff expected. The recharge trench should be periodically cleaned of accumulated debris to maintain the intake capacity.

In terms of recharge rates, recharge trenches are relatively less effective since the soil strata at depth of about 1.5 metres is less permeable.

### Design of a recharge trench

The methodology of design of a recharge trench is similar to that for designing a settlement tank. The difference is that the water



**Figure 3.22** Recharge pit constructed along periphery of building and detailed section of recharge pit

holding capacity of a recharge trench is less than its gross volume because it is filled with porous material. A factor of loose density (voids ratio) of the media has to be applied to the equation.

Using the same method as used for design of settlement tank:

Area of rooftop catchment (A) = 100 sq. m.

Peak rainfall in 15 min (r) = 25 mm (0.025 m)

Runoff coefficient (C) = 0.85

Voids ratio (D) = 0.5 (assumed)

Required capacity of recharge tank

$$= (A \times r \times C) / D$$

$$= (100 \times 0.025 \times 0.85) / 0.5$$

$$= 4.25 \text{ cu. m. (4,250 litres)}$$

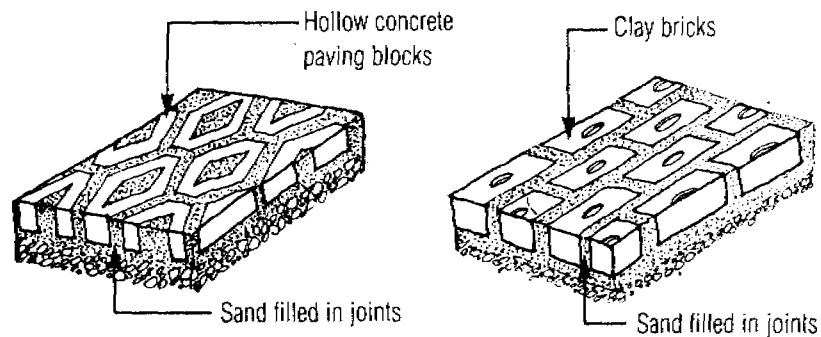
The voids ratio of the filler material varies with the kind of material used, but for the commonly-used materials like brickbats, pebbles and gravel, a voids ratio of 0.5 may be assumed.

In designing a recharge trench, the length of the trench is an important factor. Once the required capacity is calculated as illustrated above, length can be calculated by considering a fixed depth and width.

## 5. Permeable Surfaces

Unpaved surfaces have a greater capacity of retaining rainwater on the surface. A patch of grass would retain a large proportion of the rainwater falling on it, yielding only 10-15 per cent as runoff (see figure 3.6 on p6). A considerable amount of water retained on such a surface will naturally percolate in the ground. Such surfaces contribute to the natural recharge of groundwater.

If paving of ground surfaces is unavoidable, one may use pavements which retain rainwater and allow it to percolate into the ground (see figure 3.23 on p17).



**Figure 3.23** Permeable Pavements

### Special precautions

Whether the harvested water is used for direct usage or for recharging the groundwater, it is of utmost importance to ensure that the rainwater collected is free of any pollutants that might be added to rainwater from the atmosphere or the catchment. While polluted water directly used for consumption would have an immediate impact on health, polluted water recharged into the groundwater would cause long-term problems of aquifer pollution. Damage done to aquifers by recharging polluted water is irreversible.

Most of the precautions to ensure rainwater quality have been described earlier in the manual. Here, all the measures have been summarised:

1. At the catchment level
  - Keeping the catchment clean
  - Using gratings to trap debris at the catchment itself
  - Paving the catchment with ceramic tiles, stone tiles or other such non-erosive materials
2. At the conduit level

- Provision of first-flush to drain runoff from initial spell of rain
3. Before recharging
    - Allowing for sedimentation of the water
    - Filtering the water

In establishments like industries, it is very necessary to ensure that the catchment surfaces are free of chemical wastes, fuels, lubricants etc. While physical and biological impurities in water can be easily removed by desedimentation and filtration, it is difficult to remove chemical impurities.

### Cost of water harvesting

Typically, installing a water harvesting system in an building would cost between Rs 2,000 to 30,000 for buildings of about 300 sq. m. It is difficult to make an exact estimate of cost because it varies widely depending on the availability of existing structures like wells and tanks which can be modified to be used for water harvesting.

The cost estimate mentioned above is for an existing building. The costs would be comparatively less if the system were incorporated during the construction of the building itself.

Some basic rates of construction activities and materials have been given here, which may be helpful in calculating the total cost of a structure. The list is not comprehensive and contains only important activities meant to provide a rough estimate of the cost (see table 3.2 on p18).

### Scale of water harvesting

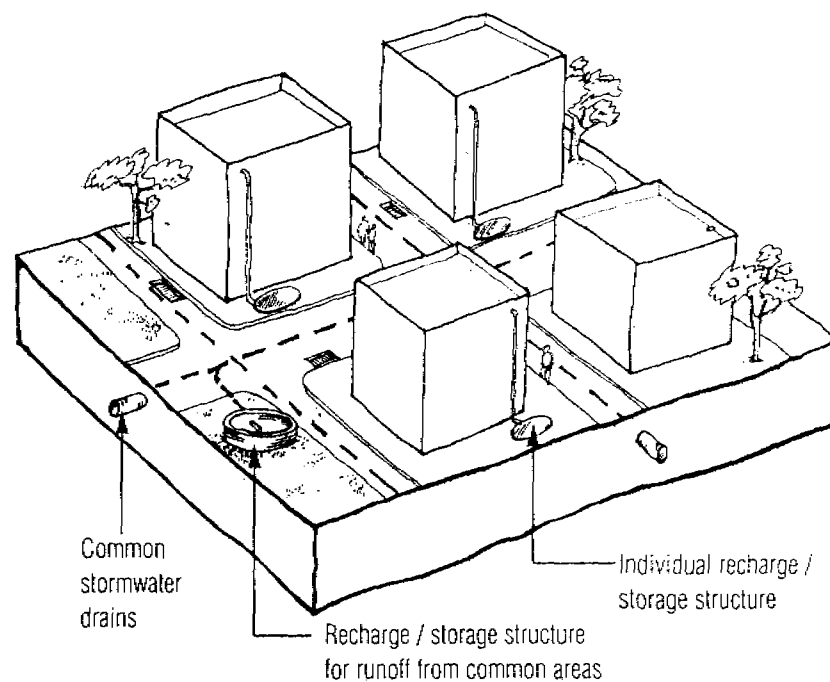
Most methods described in this manual are applicable at a singular building or establishment level. However, the same principles can be applied for implementing water harvesting at a larger scale, say, a residential colony or an institutional cluster. To an extent, the nature of structures and design parameters remain the same; the physical scale and number of structures may

**Table 3.2 Approximate costs of common items or work in water harvesting**

Activity	Unit	Rate (Rs.)
Excavation in soils	cu. m.	65.00
Excavation in rock	cu. m.	110.00
Brickwork with cement mortar (1:6)	cu. m.	1190.00
Plain cement concrete (1:3:6)	cu. m.	1300.00
Reinforced cement concrete (1:2:4)	cu. m.	1740.00
Centering and shuttering	sq. m.	90.00
GI piping		
100 mm diameter	metre	375.00
150 mm diameter	metre	590.00
PVC piping for rainwater pipes		
110 mm diameter	metre	165.00
200 mm diameter	metre	275.00
Making shallow soakaway in soft soil (with 150 mm diameter PVC casing)	metre	300.00
Making deep recharge borewell using mechanical rotary drilling	metre	1300.00

increase corresponding to the size of catchment.

To control the total amount of runoff received by a large-scale system, the catchment can be subdivided into smaller parts. A locality-level water harvesting system illustrated in figure 3.24 shows how the runoff from individual houses can be dealt with at the building-level itself, while remaining runoff from the stormwater drain (which drains water from roads and open areas) can be harvested by constructing recharge structures in common areas.



**Figure 3.24** Tapping stormwater drains in a community-level system



# CHAPTER 4

## CASE STUDIES

### 1. Centre for Science and Environment, New Delhi

#### Case Background

The total area of the Centre for Science and Environment (CSE) building is 1,000 sq. m. The office gets most of its water supply from groundwater through its borewell. The water harvesting system was installed in the building in June 1999.

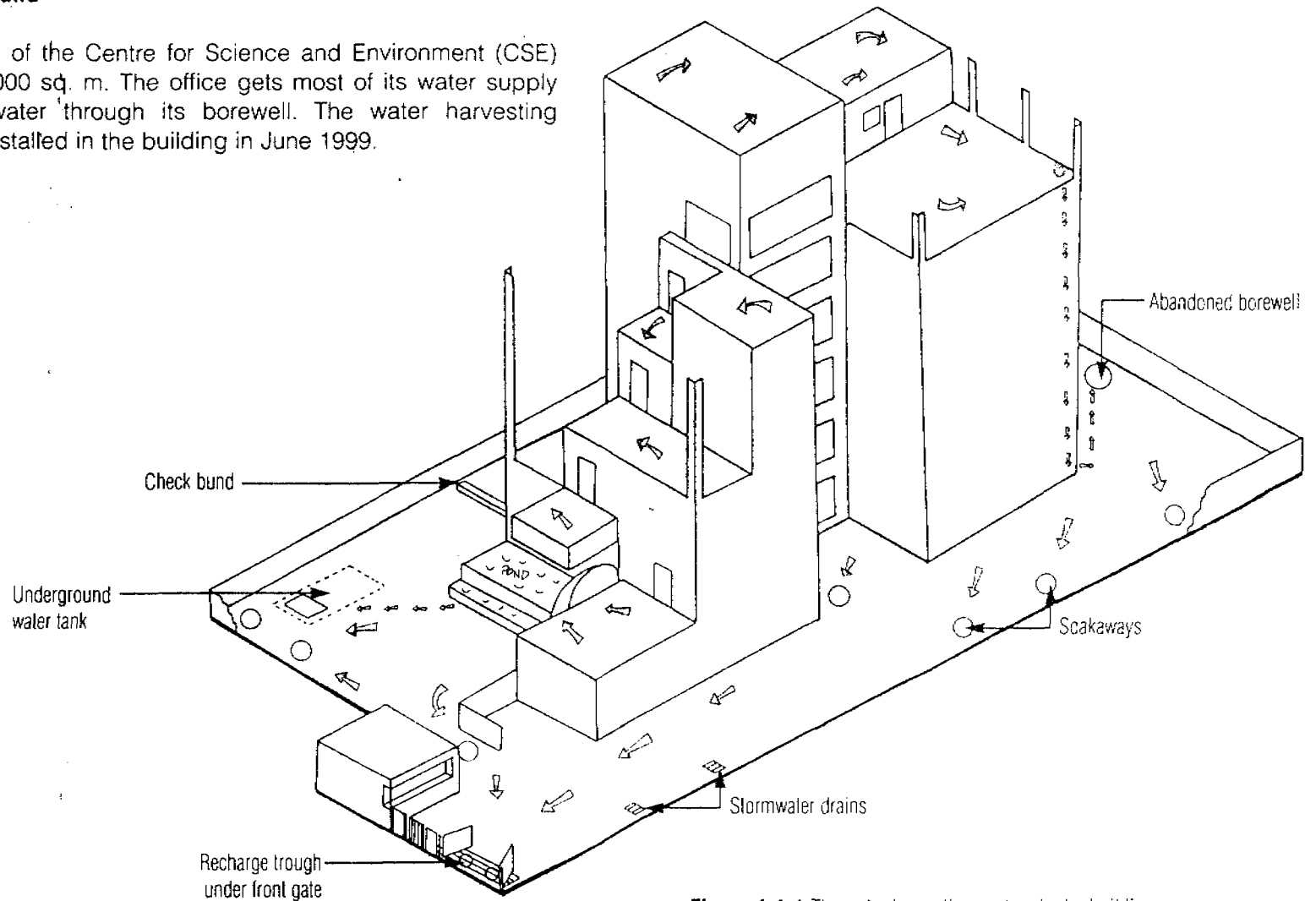


Figure 4.1.1 The water harvesting system in the building

## Measures taken for water harvesting

A major portion of the rainwater is recharged into the groundwater aquifers. A small amount is stored in an underground tank for low-quality uses. Annual water harvesting potential at CSE is 366,600 litres. A combination of methods used for harvesting the rainwater ensure that most of the rainwater falling over the building area is recharged or stored (see figure 4.1.1 on p19).

The cost of installing the system was Rs. 36,000.

### a. Recharging of abandoned borewell

Rainwater from the rear portion of the terrace is led through a vertical drainpipe to the 45 m deep abandoned borewell. An aluminum grating prevents debris from entering the borewell. The borewell and the sump on top are filled with filter media of brick-bats to trap debris (see figure 4.1.2).

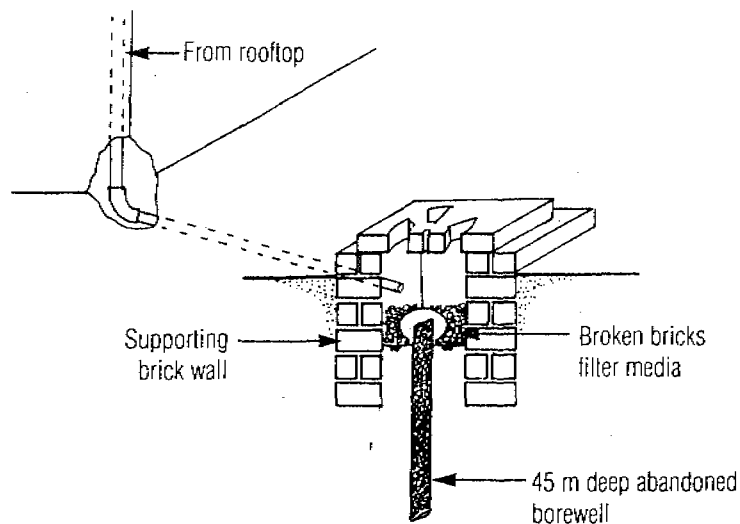


Figure 4.1.2 Detail of abandoned borewell recharging

### b. Soakaway

Thirteen soakaways have been constructed around the building. A soakaway is a vertical shaft of 150 mm (6") diameter bored in the ground to a depth of 30 feet and cased with a PVC pipe. The mouth of the shaft is covered with an inverted earthen pot with a small hole to prevent the entry of debris into the shaft. A small sump is constructed around the top of the shaft, which is filled with a filter media of brickbats to prevent entry of debris. A perforated RCC cover is placed on top of sump to allow the entry of rainfall runoff (see figure 4.1.3).

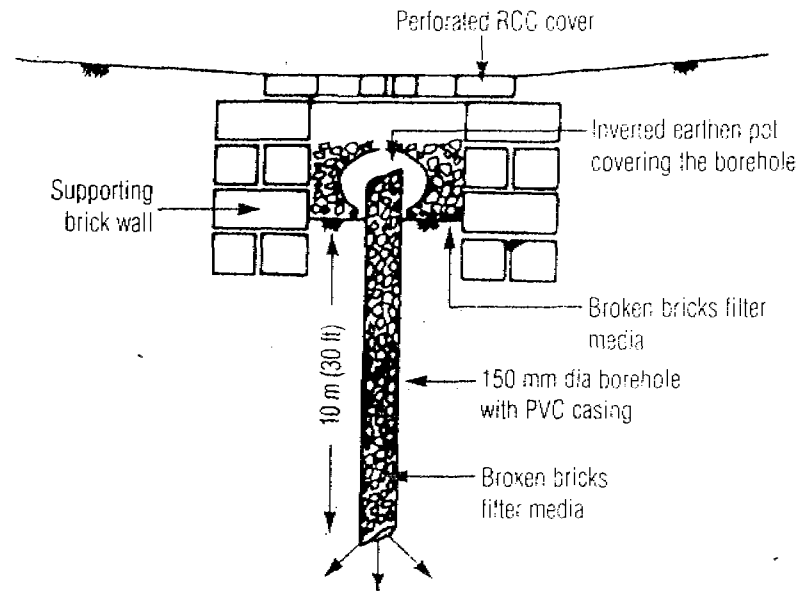


Figure 4.1.3 Detail of soakaway

### c. Rainwater storage tank

The front facade of the building has terraces projecting out at various floors. The rainwater drainpipes from all terraces are

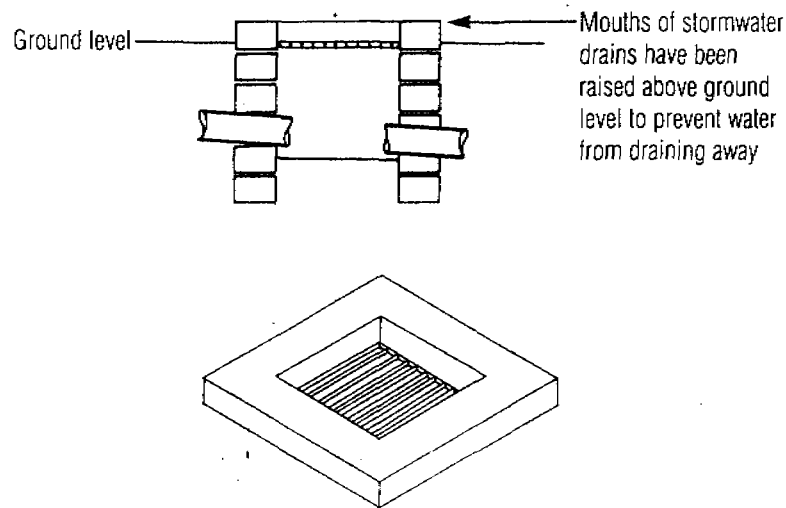
connected in series so that the runoff from these terraces falls into the pond in the front of the building. When this pond overflows, water flows to the underground tank of 8,500 litre capacity. Water from this rainwater storage tank is used for low-quality uses like gardening.

#### d. Recharge trough

Three soakaways have been constructed in the trough under the entrance gate, which is covered with an iron grill. The runoff flowing out through the entrance is collected in this trough and gets recharged through the soakaways.

#### e. Raising of stormwater drains

Openings of the municipal stormwater drains within the campus area have been raised slightly above the ground level, so that rainwater does not drain away (see figure 4.1.4).



**Figure 4.1.4** Details of stormwater drains

## 2. Rashtrapati Bhavan, New Delhi

### Case Background

In November 1998, President K R Narayanan invited CSE to suggest measures to harvest water at the Rashtrapati Bhavan. An advisory committee was set up by CSE, which developed a plan for water harvesting at the Rashtrapati Bhavan. The implementation of the scheme is being undertaken by the Central Public Works Department (CPWD) and Central Ground Water Board (CGWB).

The Presidential Estate covers an area of 133 hectares (1.33 sq. km.). The water requirements of the presidential estate are huge since there are about 7,000 people residing in the estate. Approximately 3,000 people visit the presidential premises everyday. The Mughal Gardens in the estate require a lot of water. The total demand is about 2 million litres of water per day (730 million litres per year). This demand is met through the New Delhi Municipal Corporation supply and the estate's own borewells.

Since about 35 per cent of the water requirements are being met through groundwater sources, there had been an alarming decline of groundwater levels in the estate. Levels have gone down by 2 to 7 m in the past decade, with one well running dry.

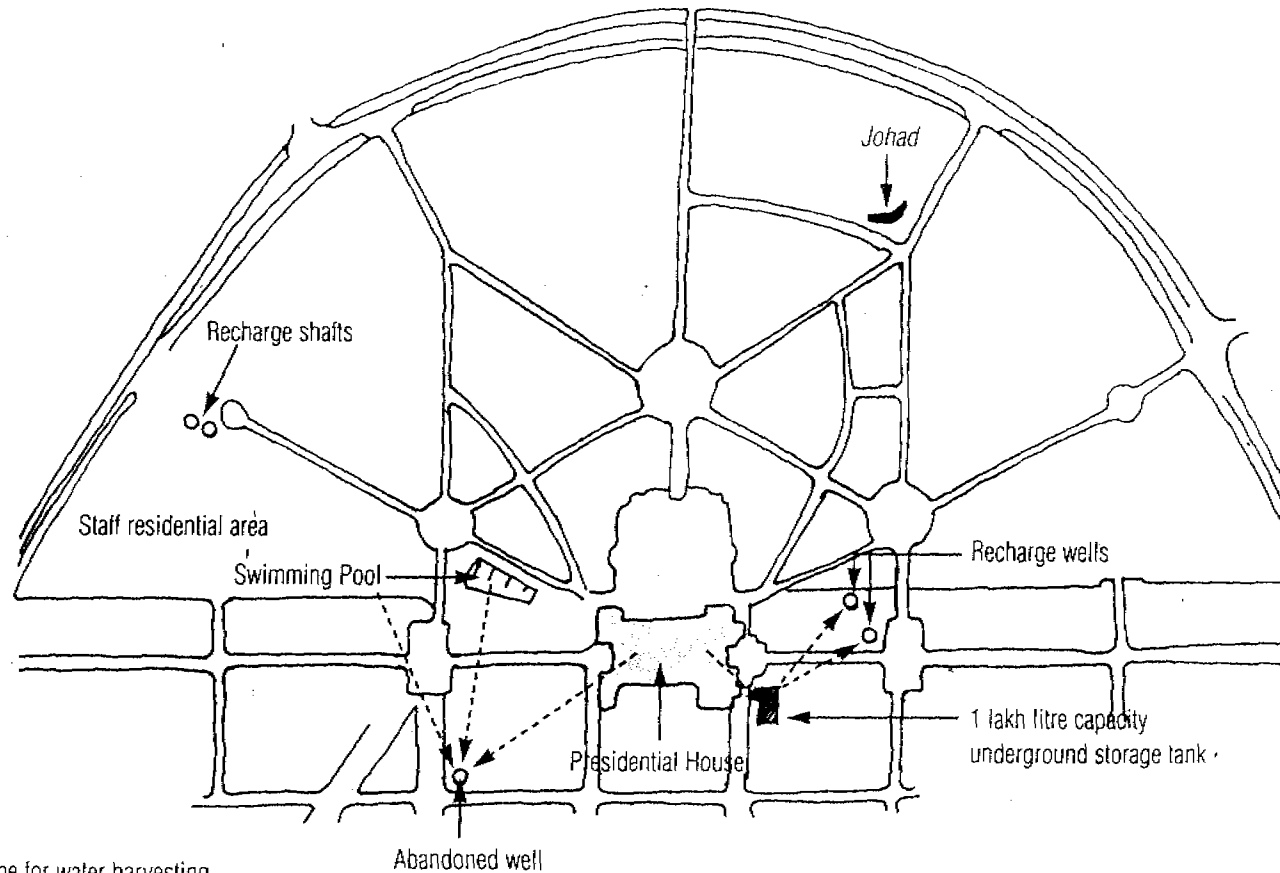
### Measures taken for water harvesting

The rainwater endowment of the area is 811 millions litres annually. Estimated cost of installing the system is Rs. 20 lakh (work on some components of the system was still underway in May 2000).

Following measure have been planned for the estate (see figure 4.2.1 on p22):

#### a. Rainwater storage tank

Rainwater from the northern side of roof and paved areas surrounding Rashtrapati Bhavan is diverted to an underground storage tank of 1 lakh litre capacity for low quality use.



SITE PLAN

**Figure 4.2.1** Scheme for water harvesting

**b. Well recharging**

Overflow from the 1 lakh litre capacity rainwater storage tank mentioned above is diverted to two dugwells for recharging. Rainwater from the southern side of the roof is diverted for recharging a dry open well. Rainfall runoff from the staff residential area is also diverted to the dry well. Water passing into the recharge well is passed through a desilting tank to remove pollutants. The 9 lakh litre capacity swimming pool in the estate is planned to be

connected to the dry dugwell, so that during periodic emptying of the pool, water can be used for recharging instead of being drained away.

**c. Recharge shaft.**

15 m deep recharge shafts will be constructed in the staff residential area. Rainwater available from rooftops, roads and parks will be used for recharging.

#### d. Johad

A *johad* is a crescent-shaped bund which is built across a sloping catchment to capture the surface runoff. Water accumulating in the *johad* percolates in the soil to augment the groundwater. *Johads* have traditionally been used in Rajasthan for harvesting water. A *johad* is planned to be constructed near the Mughal Gardens.

### 3. Residence at Vasant Vihar, New Delhi

#### Case Background

The area of the property is about 500 sq. m., with a rooftop area of 300 sq. m. (600 sq. yd.). A private borewell in the building is the only source of water to the house.

The building also has an 45 m deep abandoned borewell in its area, which had run dry in November 1999. A new 100 m deep borewell was established adjacent to the new one.

#### Measures taken for water harvesting

The dry borewell present in the building provides an excellent opportunity for recharging the groundwater (see figure 4.3.1). Annual water harvesting potential from the rooftop is 109,000 litres.

The cost of installing this system was Rs 33,000.

#### a. Recharging of abandoned borewell

Runoff from the rooftop is discharged into the dry borewell. To ensure that suspended impurities in the water do not enter the borewell, the water is passed through a settlement tank of about 7500 litres capacity (see figure 4.3.2 on p24).

An unused underground tank located near the borewell has been modified to be used as a settlement tank. All the rainwater drainpipes leading from the terrace are connected to the

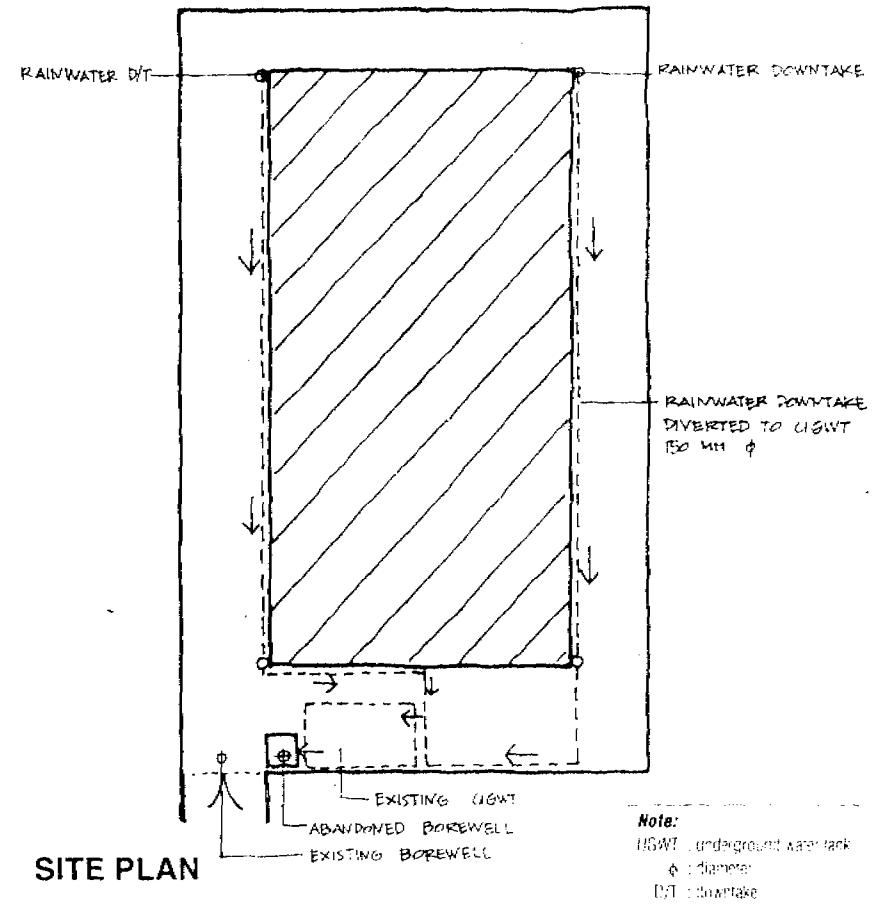


Figure 4.3.1 Scheme for water harvesting

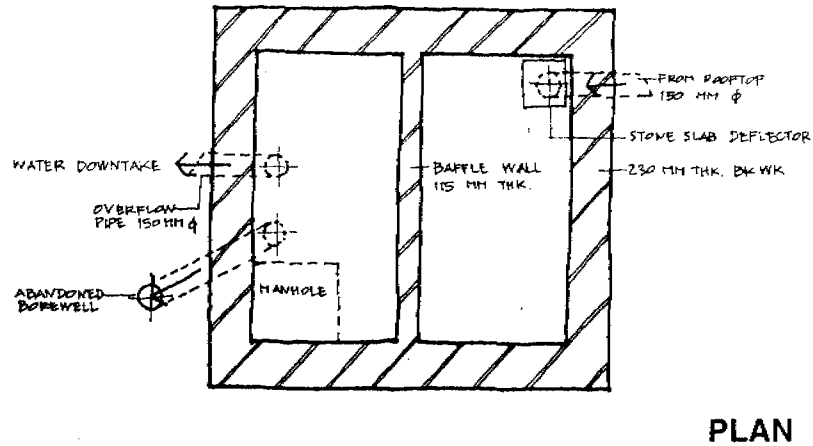
underground settlement tank. The bottom of the tank has been left unpaved and lined with a bed of brick-bats to allow the percolation of standing water in the tank.

## 4. Institute of Economic Growth, New Delhi

### Case Background

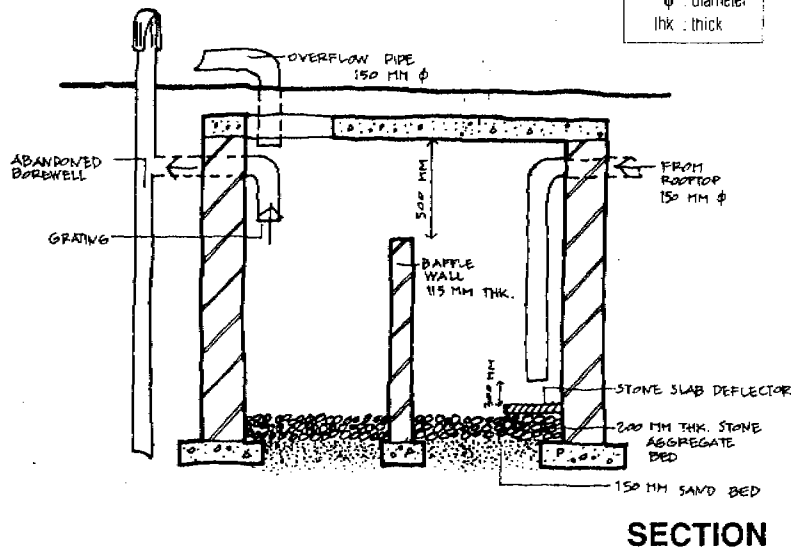
The Institute of Economic Growth located in the Delhi University area, has a campus area of about 3 ha. The campus houses both the official buildings and residential quarters.

The campus had been facing water problems since the the water supply received from the municipal corporation is found to be inadequate. The groundwater in the area cannot be used for consumptive purposes since it shows high levels of sulphates, fluorides and hardness. Water from three borewells (see figure 4.4.1) in the campus is used for low quality uses like gardening and flushing. Daily water requirement is approximately 55,000 litres (annual requirement of 20 million litres).



PLAN

**Note:**  
 BKWK : brickwork  
 φ : diameter  
 thk : thick



SECTION

Figure 4.3.2 Details of recharge borewell and settlement tank

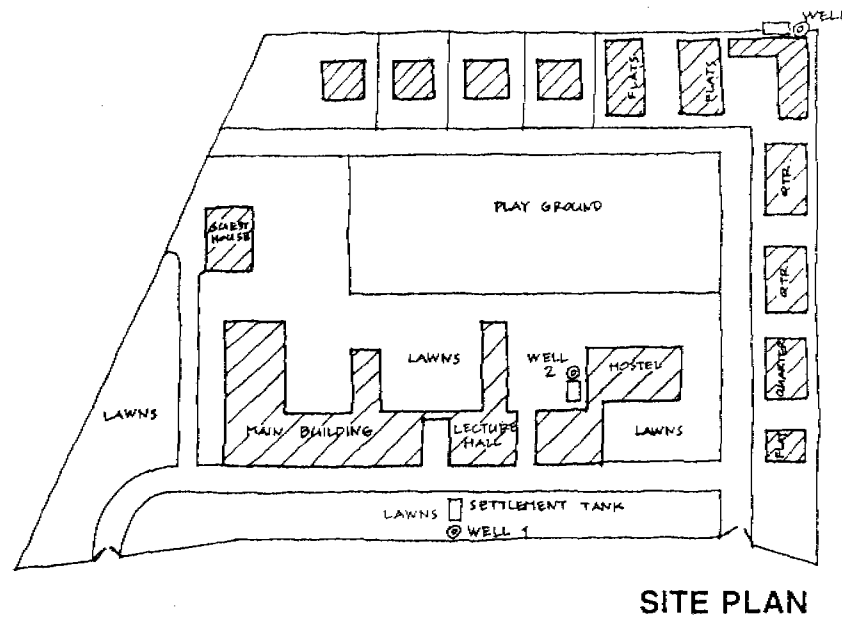


Figure 4.4.1 Scheme of water harvesting

Proposed scheme for w  
 Although the water from  
 purposes, the quality v  
 limits. The quality of s  
 recharging the groundw  
 the concentration of har  
 Total water harvesting p

Estimated cost of in all  
 tation was yet to be star

**a. Recharge borewells**  
 Runoff from rooftops of  
 about 2,200 sq. m. will  
 passing through settlem  
 The 150 mm diam  
 extracting water for no  
 (see figure 4.4.4 on p26

**b. Recharge trenches and**  
 Runoff from ground wat  
 be recharged through r

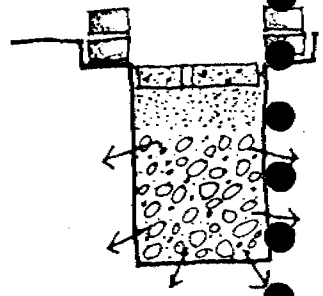


Figure 4.4.2 Details of recharge borewell

### Proposed scheme for water harvesting

Although the water from the borewell was found unfit for drinking purposes, the quality was only slightly worse than permissible limits. The quality of such groundwater can be improved by recharging the groundwater as recharged rainwater tends to dilute the concentration of harmful salts and minerals in the groundwater. Total water harvesting potential of the site is 10.46 million litres.

Estimated cost of installing the system is Rs. 1.7 lakh. (implementation was yet to be started in May 2000).

#### a. Recharge borewells

Runoff from rooftops of three buildings encompassing an area of about 2,200 sq. m. will be diverted to the existing borewells after passing through settlement tanks of about 15,000 litres capacity. The 150 mm diameter borewells, which are already in use for extracting water for non-drinking purposes, are 10-12 m deep (see figure 4.4.4 on p26).

#### b. Recharge trenches and recharge pits

Runoff from ground catchments like the playground and lawns will be recharged through recharge trenches and recharge pits.

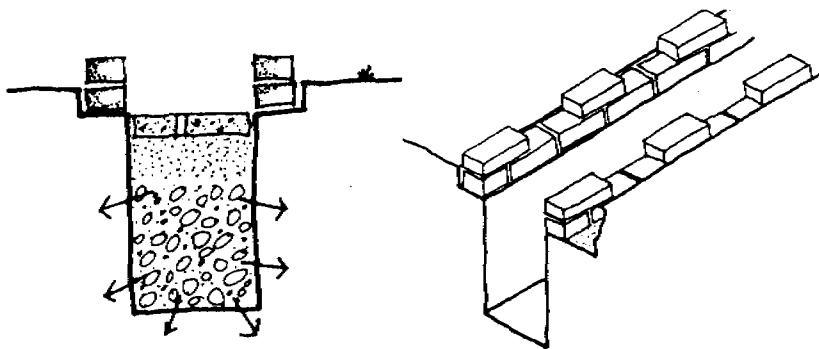
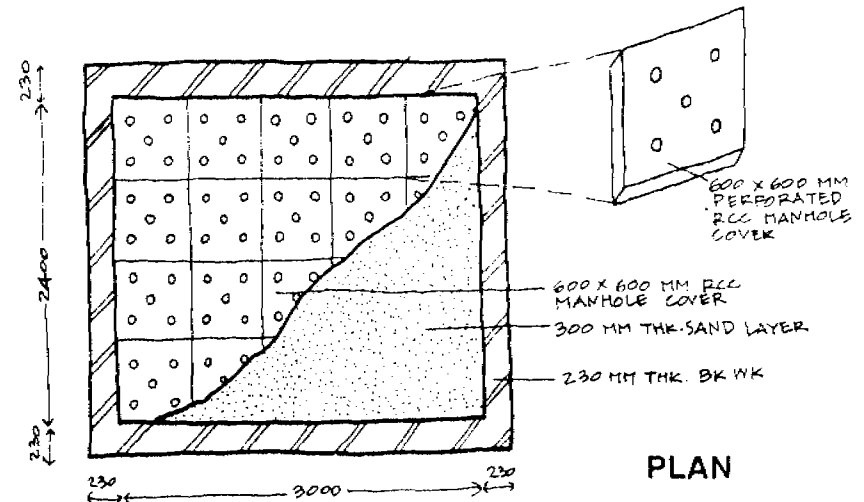
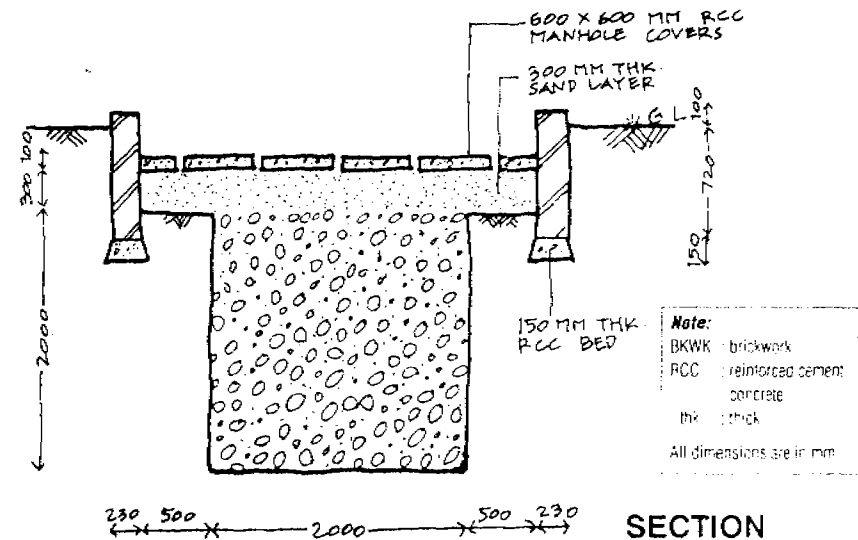


Figure 4.4.2 Details of recharge trench

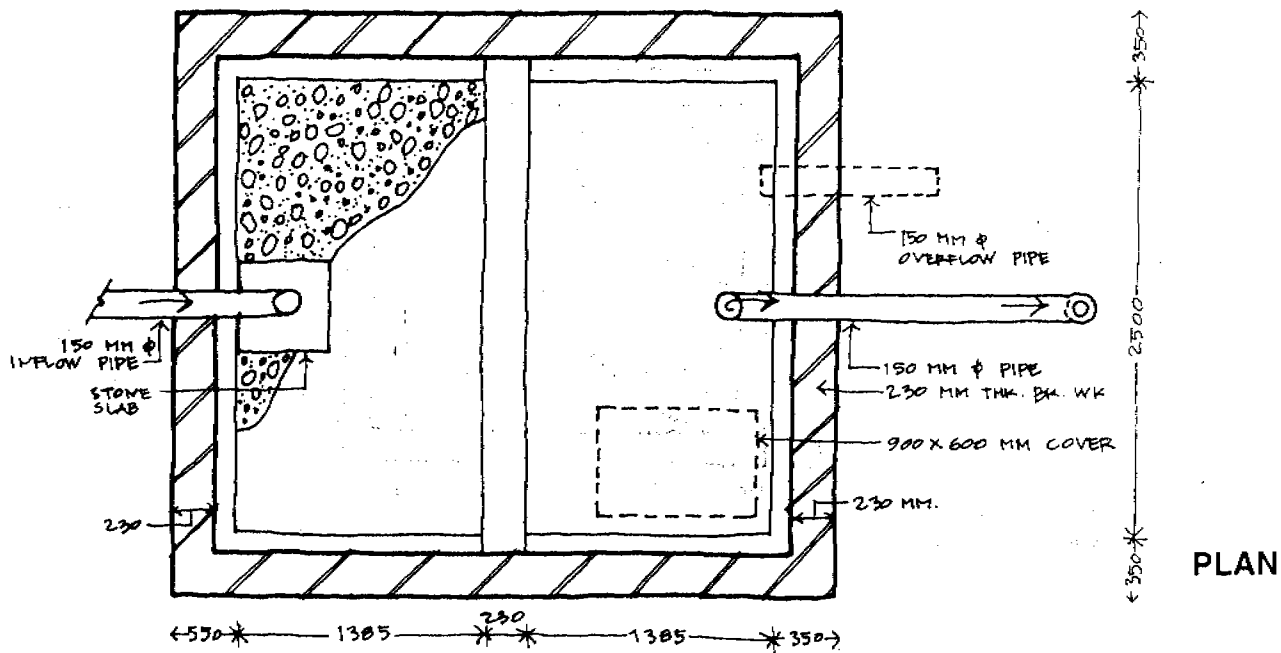


PLAN



SECTION

Figure 4.4.3 Details of recharge pit



**Note:**  
 BKWK : brickwork  
 RCC : reinforced cement concrete  
 $\phi$  : diameter  
 thk : thick  
 All dimensions are in mm

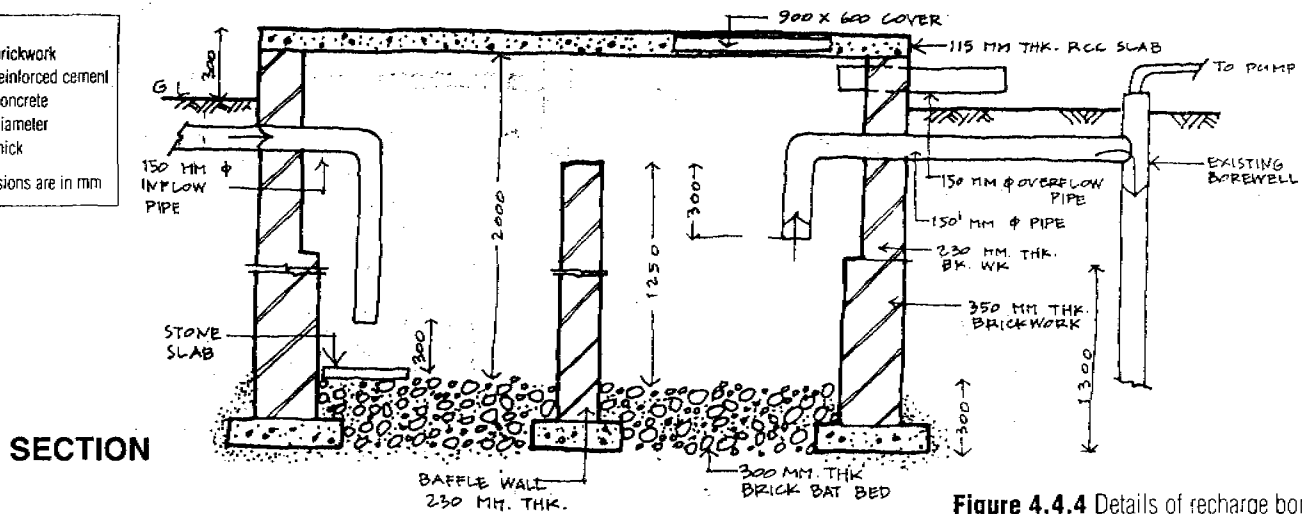


Figure 4.4.4 Details of recharge borewell and settlement tank



## 5. Gapps Industries, Gurgaon

### Case Background

The factory complex having an area of approximately 3 hectares consists of 4 industrial buildings and a common effluent treatment plant.

The daily requirement for water for both industrial and consumptive use in the factory is approximately 110,000 litres (annual requirement of 40.15 million litres). Borewells installed in the main area of the factory yield water with high content of dissolved solids (salts), making it unsuitable for use in the industrial processes. The factory has to get its water supply from a borewell installed at a distant location.

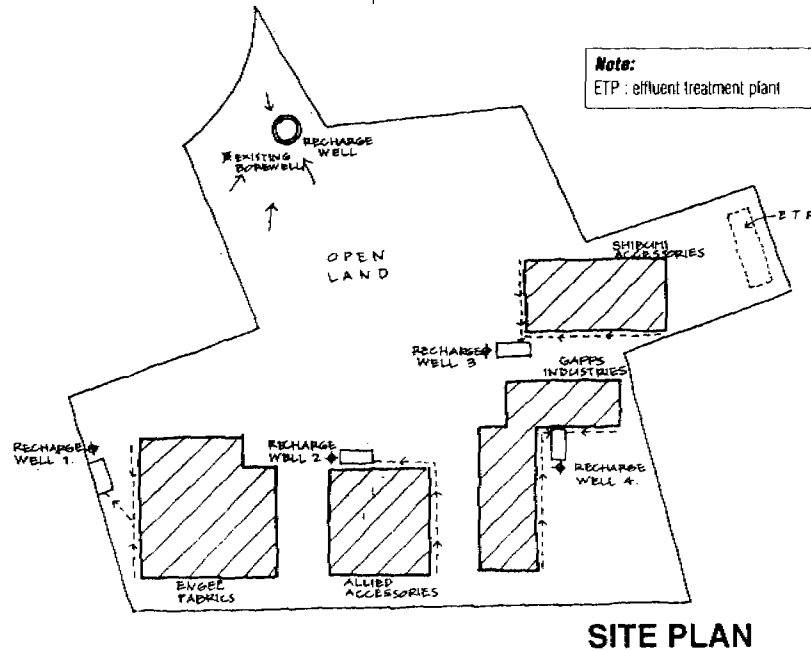


Figure 4.5.1 Scheme for water harvesting

### Proposed scheme of water harvesting

Water harvesting can provide a long-term solution both to the problem of groundwater quantity and quality. Various measures have been taken to harvest water (see figure 4.4.1). Groundwater recharging can be instrumental in reducing the concentration of salts in the groundwater by dilution. The total water harvesting potential of the site is 9.78 million litres annually. Estimated cost of

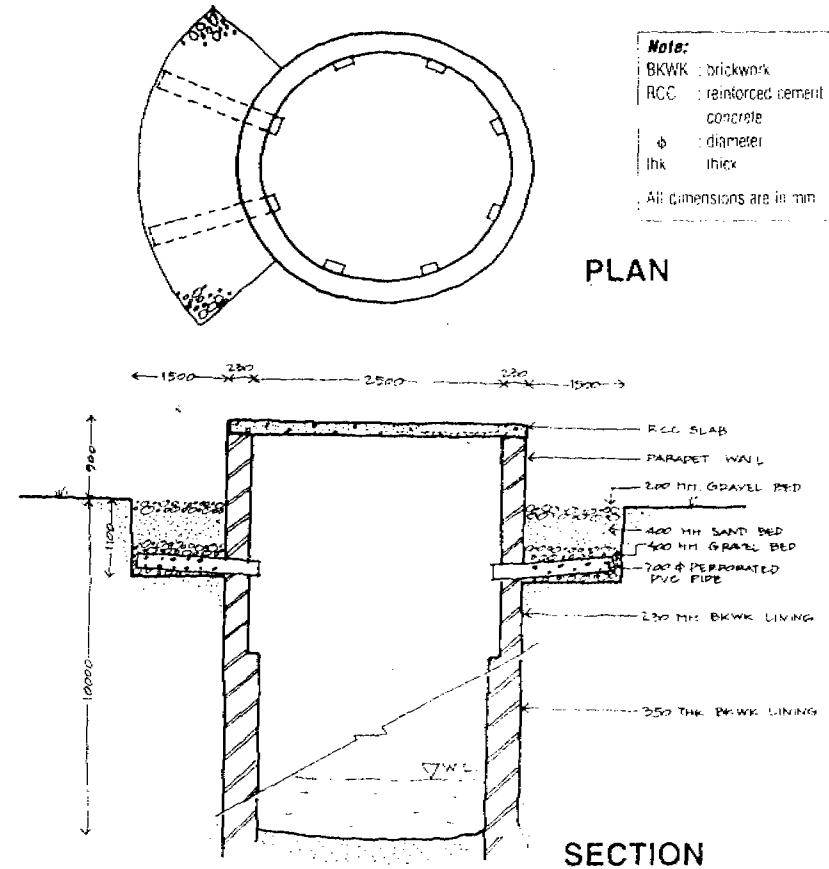


Figure 4.5.2 Details of recharge dugwell

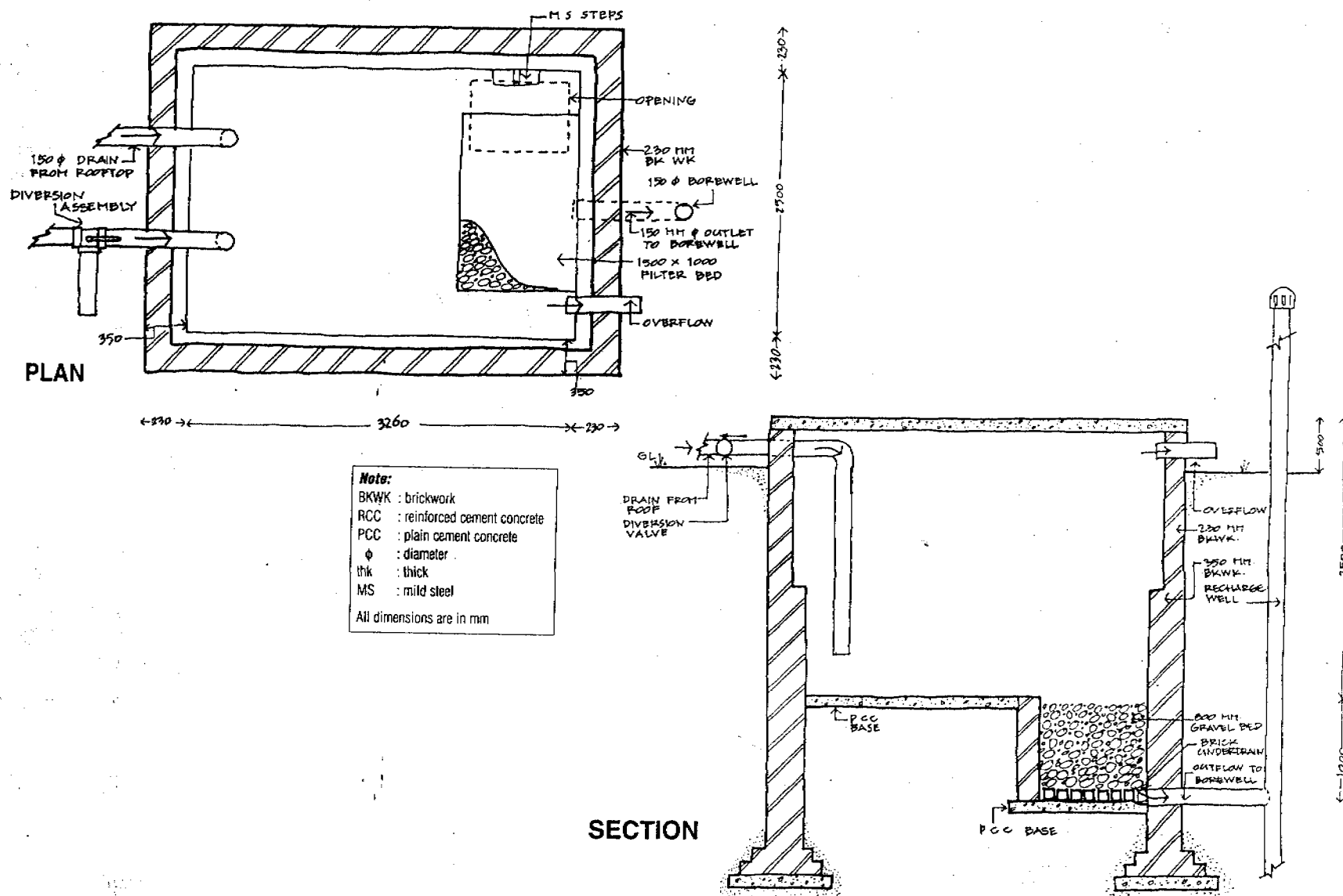


Figure 4.5.3 Details of recharge borewell and filtration tank

installing the... started in May 20...

**a. Recharge dugw...**

An open area of... for dugwell re... diameter is prop... catchment. A... well. Water accu... and enter the we... of the filter bed (...)

**b. Recharge borew...**

The rooftop r... area of about 50... groundwater... borewells of 9 m... borewell will be u...

The rainwater... diverted to the bo... tanks are of 35 00...

A diversion va... desilting char... runoff from the fi... dust and debris... recharging system

**c. Recharge trench**

Most of the o... ings can be used... structures like re... locations (see fig... decided by identi...

installing the system is Rs. 2.13 lakh (implementation was yet to be started in May 2000).

#### a. Recharge dugwell

An open area of about 0.6 ha has been identified as a catchment for dugwell recharging. A 10 m deep recharge dugwell of 2.5 m diameter is proposed to be constructed at the lowest point of the catchment. A filter bed will be made on the outer perimeter of the well. Water accumulated near the well will seep into the filter bed and enter the well through perforated PVC pipes laid at the bottom of the filter bed (see figure 4.5.2 on p27).

#### b. Recharge borewells

The rooftop runoff from all the four buildings, encompassing an area of about 5000 sq. m., can be used to directly recharge the groundwater through borewells. Four separate 150 mm diameter borewells of 9 m depth will be used for recharging. One existing borewell will be used for recharging.

The rainwater drain-pipes from the roofs of the buildings will be diverted to the borewells after passing through filtration tanks. The tanks are of 35,000 to 50,000 litres capacity.

A diversion valve will be provided before the pipe enters the desilting chamber. This valve will be operated to allow the initial runoff from the first showers of the season to flow away, so that dust and debris accumulating on the terrace does not enter the recharging system (see figure 4.5.3 on p28).

#### c. Recharge trenches and recharge pits

Most of the other open areas in the campus apart from the buildings can be used as catchments by constructing simple recharge structures like recharge trenches and recharge pits at suitable locations (see figure 4.4.2 and 4.4.3 on p25) These locations are decided by identifying low-lying areas where water accumulates.

## 6. The Sri Ram School, New Delhi

### Case Background

The area of the school campus is about 6,000 sq. m. The school depends entirely on its private borewell for water supply drawing groundwater from a depth of 45 m.

### Proposed scheme for water harvesting

The total water harvesting potential of the school is 1.89 million litres annually. Rainfall runoff is divided in two categories – rooftop runoff and ground runoff. While the entire rooftop runoff is recharged through recharge borewells, the ground runoff is recharged through surface structures like recharge trenches and pits (see figure 4.6.1).

Estimated cost of installing the system is Rs. 70,000. (implementation was underway in May 2000)

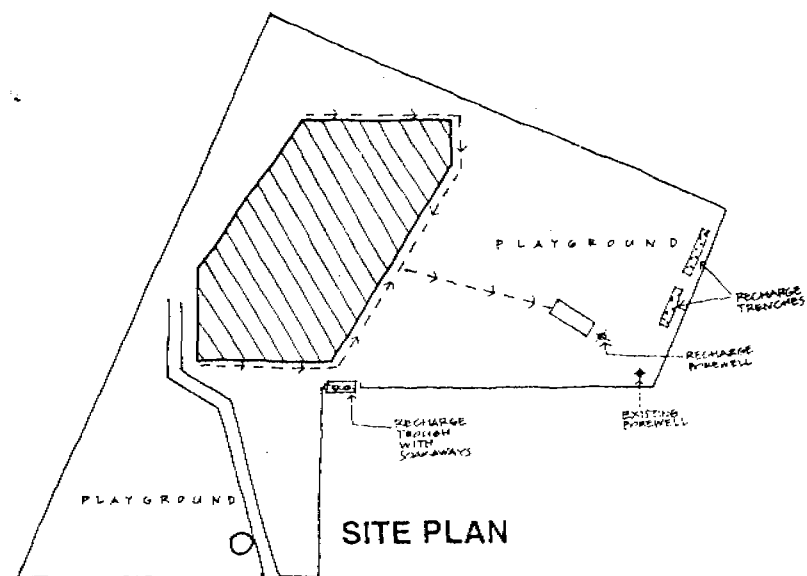
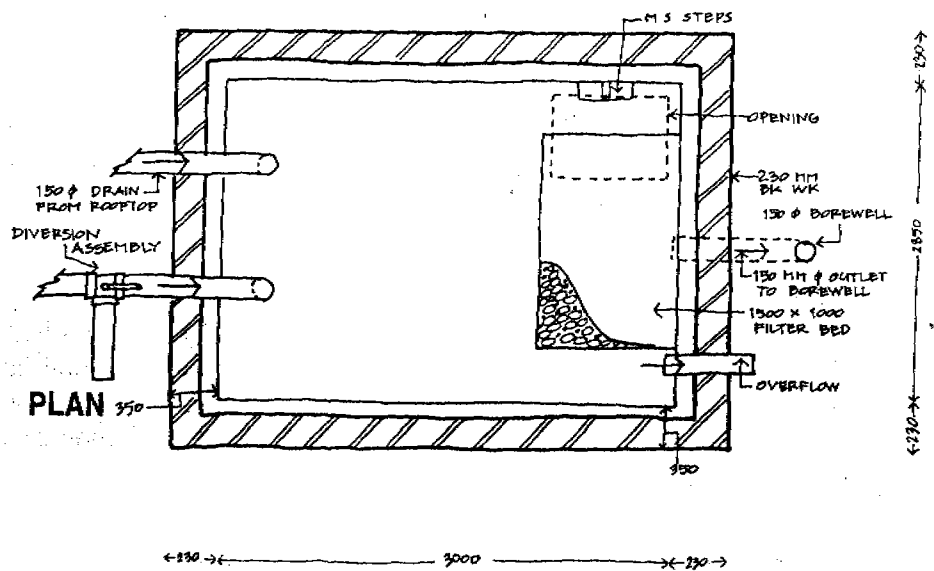
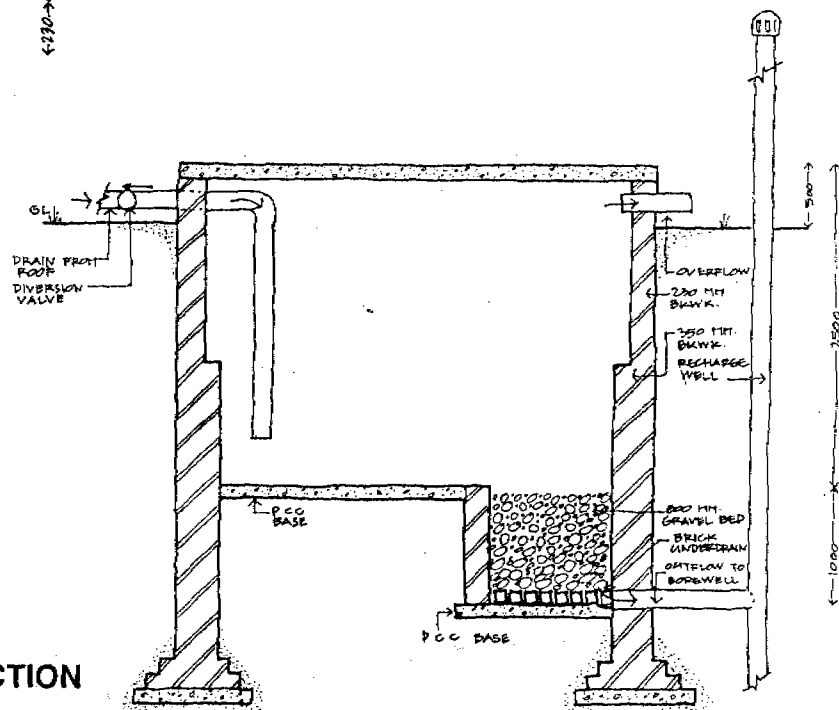


Figure 4.6.1 Scheme for water harvesting



**Note:**  
 BKWK : brickwork  
 RCC : reinforced cement concrete  
 PCC : plain cement concrete  
 φ : diameter  
 thk : thick  
 MS : mild steel  
 All dimensions are in mm



**SECTION**

**Figure 4.6.2** Details of recharge borewell and filtration tank

- a. **Recharge borewell**  
 Runoff from the roof is collected in a recharge borewell of about 21,250 l diameter and depth. The recharge borewell allows horizontal seepage.
- b. **Recharge trench**  
 Runoff from ground is recharged through a trench to be constructed at the bottom of the tank.
- c. **Recharge trough**  
 A huge amount of runoff is collected through a service trough and is recharged through a service trough at the bottom of the tank.

### a. Recharge borewells

Runoff from the rooftop of about 1,000 sq. m. will be diverted to a recharge borewell after passing through a filtration-cum-buffer tank of about 21,250 litre capacity. A recharge borewell of 200 mm diameter and depth of 30 m will be drilled for the purpose. The recharge borewell will be cased with a slotted pipe (MS or PVC) to allow horizontal seepage also (see figure 4.6.2).

### b. Recharge trenches and recharge pits

Runoff from ground catchments like the playground will be recharged through recharge trenches and recharge pits which will be constructed at suitable locations.

### c. Recharge trough and soakaways

A huge amount of surface runoff flows out through the building through a service gate on the side of the building. A recharge trough is proposed to be built under the gate, with soakaways at the bottom of the trough (see figure 4.6.3).

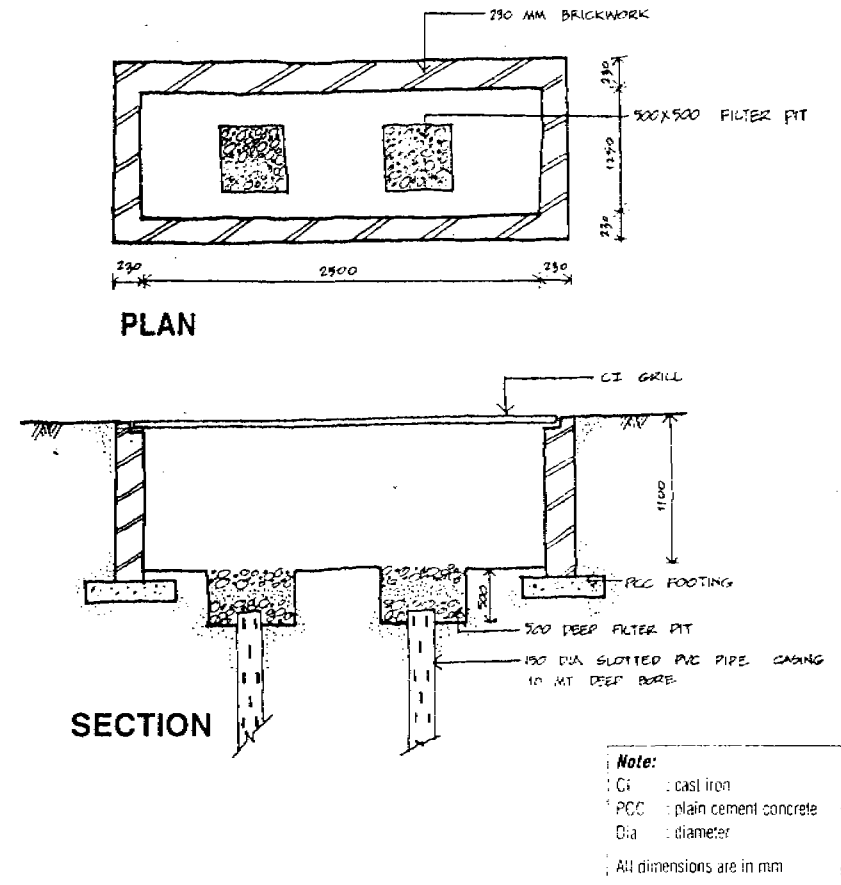


Figure 4.6.3 Details of recharge trough and soakaways

## FREQUENTLY ASKED QUESTIONS

### 1. If I use rainwater from my rooftop to recharge the groundwater, will the benefits not disperse to other water users in the neighbourhood?

Groundwater is not static and cannot be localised to the area where it is recharged. In natural conditions, rate of groundwater flow varies widely, sometimes being as low as a few mm/day. Nature of groundwater flow also varies. In Delhi, for example, the vertical hydraulic conductivity of the soil formations is more than the horizontal hydraulic conductivity, which means that the rate of vertical (downward) passage of water through soil pores or rock fissures is more than the rate of horizontal flow.

In the presence of wells in an area, the flow of groundwater may be influenced by the wells in the close proximity. Generally, buildings which have recharge structures and also extraction wells in the same area can influence, and benefit from, the recharged groundwater to a greater extent.

Recharge water will invariably benefit groundwater users in the neighbourhood to some extents. The benefits could be more equitably distributed if water harvesting is taken up at a community-level with each user playing an active role in recharging the groundwater.

### 2. What is the cost of constructing water harvesting facilities?

Typically, installing a water harvesting system in an building would cost between Rs 3,000 to 30,000 for buildings of total plot area of about 300 sq. m. Some basic rates of construction activities have been given on p18 which may be helpful in calculating the total cost of a structure.

### 3. How can I test the water if it is fit for use?

Various water testing kits are sold at affordable prices by governmental and non-governmental agencies. In Delhi, these kits are available at:

#### a. Development Alternatives

B-32, Tara Crescent, Qutab Institutional Area,  
New Delhi – 110 016  
Tel: 696 7938, 656 5370, 685 1158  
Price: Rs. 4000/-

#### b. Central Pollution Control Board

Parivesh Bhavan  
CBD-cum-office complex,  
East Arjun Nagar,  
Shahadra, New Delhi – 110 032  
Tel: 244 7014, 2222 073, 2222 071  
Price: Rs. 1000/-

Water samples are also analysed by numerous private testing agencies. Testing a sample for some essential tests recommended IS 10500 costs approximately Rs. 1200 .

### 4. How can I treat water to render it safe for drinking?

Various measures can be taken at a household level to treat water:

#### Boiling

Boiling is a very effective method of purification and very simple to carry out. Boiling water for 10 to 20 minutes is enough to remove all biological contaminants.

#### Chemical Disinfection

##### a. Chlorination

Chlorination is done with stabilised bleaching powder (calcium hypochlorite -  $\text{CaOCl}_2$ ) which is a mixture of chlorine and lime. Chlorination can kill all types of bacteria and make water safe for drinking purposes. About 1 gm (approximately 1/4 tea spoon) of

bleaching powder

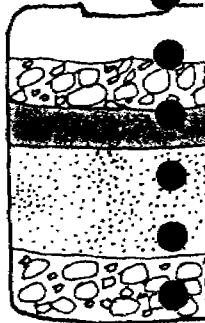
##### b. Chlorine tablets

Chlorine tablets are easy to use and a small amount is enough to disinfect water.

#### Filtration

##### a. Charcoal water filter

A simple charcoal filter can be made at home. The filter is made of activated charcoal which is easily available.



Composition of a water filter

##### b. Sand filters

Sand filters have been used for many years. They are easy to use and are employed for treating water. They remove suspended particles and some bacteria from the water.

bleaching powder is sufficient to treat 200 litres of water.

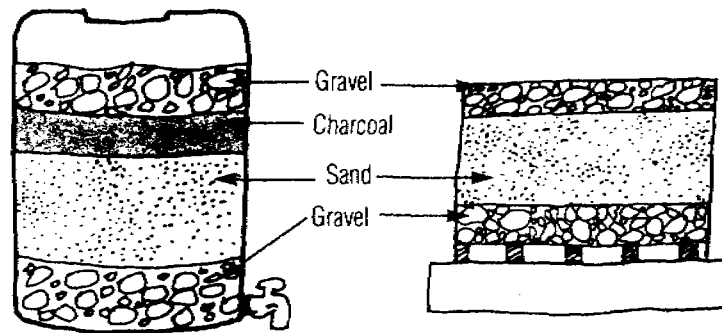
### b. Chlorine tablets

Chlorine tablets are easily available in the market. One tablet of 0.5 g is enough to disinfect 20 litres (a bucketful) of water.

## Filtration

### a. Charcoal water filter

A simple charcoal filter can be made in a drum or an earthen pot. The filter is made of gravel, sand and charcoal, all of which is easily available.



Composition of a charcoal filter

Composition of a sand filter

### b. Sand filters

Sand filters have commonly available sand as filter media. Sand filters are easy and cheap to construct. These filters can be employed for treatment of water to effectively remove turbidity (suspended particles like silt and clay), colour and microorganisms from the water.

### c. Ceramic filters

These filters are manufactured commercially on a wide scale. Most of the water purifiers available in the market are of this type.

### 5. Should I store the rainwater in containers, or should I recharge it into the groundwater aquifers?

The decision whether to store or recharge water depends on the rainfall pattern of a particular region. For example, in places like Kerala and Mizoram, it rains throughout the year, barring a few dry periods. In such places, one can depend on a small domestic-sized water tank for storing rainwater, since the period between two spells of rain is short.

In dry areas like Delhi, Rajasthan and Gujarat, the total annual rainfall occurs only during 3 or 4 months of monsoon. The water collected during the monsoon has to be stored throughout the year; which means that huge volumes of storage containers would have to be provided. Since it is not possible to create such huge containers in urban areas which tend to be short of extra space, recharging is preferred in such situations. However, at individual levels, these tanks can be constructed.

## GLOSSARY OF TERMS

**Aquifer** (also called **groundwater aquifer**): any underground formation of soil or rock which can yield water

**Artificial recharge**: any man-made scheme or facility that adds water to an aquifer is artificial recharge system

**Borewell**: small-diameter wells which are generally deeper than open wells

**Dug well**: traditionally used large-diameter wells. Defined precisely as pits excavated in the ground until the water table is reached, supported on the sides by RCC / bricks / stone walls. Diameters could vary from 0.6 metres onwards.

**Groundwater**: the water retained in the intergranular pores of soil or fissures of rock below the water table is called groundwater

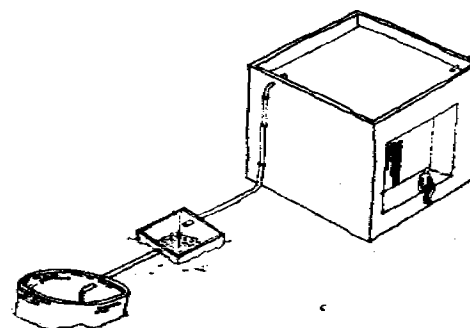
**Masonry**: a wall or other structure made using building blocks like bricks or stone with a binding material like cement or lime

**Open well**: same as dug well. These wells were kept open in earlier days for manual withdrawal of water. Today, with electrical or diesel / petrol pumps, these can be fully covered.

**Runoff**: runoff is the term applied to the water that flows away from a surface after falling on the surface in the form of rain

**Recharge**: the process of surface water (from rain or reservoirs) going to the groundwater aquifer

**Water table**: the level of water within intergranular pores of soil or fissures of rock, below which the pores of the host are saturated



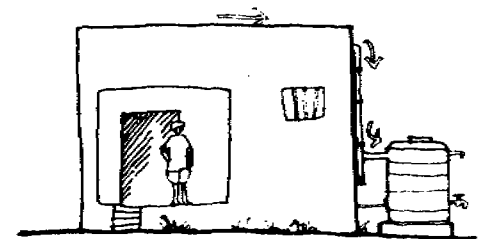
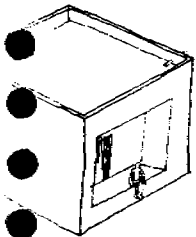
## REFERENCES

1. Serah, Marie-Helene 2001, Manohar Publishers and
2. *ibid*, p34.
3. *ibid*, p64.
4. Anon 1999, Delhi 1999 – Planning Board, New Del
5. Sharma, S K et al 1998, NCT, Delhi, Proceeding Ground Water, December Board, Delhi, pV-35.
6. Pisharoty, P R 1986, Mete Space Research Org
7. IS 1172: Indian Standard Supply, Drainage and Sa
8. Tideman, E M 1996, We Indian Conditions, One p84.



## REFERENCES

1. Serah, Marie-Helene 2000, *Water – Unreliable supply in Delhi*, Manohar Publishers and Distributors, New Delhi, p33.
2. *ibid*, p34.
3. *ibid*, p64.
4. Anon 1999, *Delhi 1999 – A Fact Sheet*, National Capital Region Planning Board, New Delhi, p36.
5. Sharma, S K *et al* 1998, *Artificial recharge to ground water in NCT, Delhi*, Proceeding of Seminar on Artificial Recharge of Ground Water, December 15-16, 1998, Central Ground Water Board, Delhi, pV-35.
6. Pisharoty, P R 1986, *Meteorology for the Indian Farmers*, Indian Space Research Organisation, Bangalore, p19.
7. *IS 1172: Indian Standard Code of Basic Requirements for Water Supply, Drainage and Sanitation*
8. Tideman, E M 1996, *Watershed Management: Guidelines for Indian Conditions*. Omega Scientific Publishers, New Delhi, p84.



# CSE Publications

## STATE OF INDIA'S ENVIRONMENT

**First Citizens' Report-1982 (SOE-1)**  
Hardbound Rs. 290 US \$12  
Paperback Rs. 190 US \$10

**Second Citizens' Report-1984-85 (SOE-2)**  
Hardbound Rs. 490 US \$18  
Paperback Rs. 290 US \$12

**Third Citizens' Report-1991 (SOE-3)**  
**Floods, Floodplains & Environmental Myths**  
Hardbound Rs. 290 US \$12  
Paperback Rs. 190 US \$10

**Fourth Citizens' Report-1997 (SOE-4)**  
**Dying Wisdom: Rise, Fall and Potential of India's  
Traditional Water Harvesting Systems**  
Paperback Rs. 290 US \$12  
Hindi Rs. 100

**Citizens Fifth Report-1999 (SOE-5)**  
(Under reprint)  
Part I: National Overview  
Part II: Statistical Database

**Towards Green Villages**  
**A Strategy for Environmentally Sound and  
Participatory Rural Development**  
Paperback Hindi Rs. 30 US \$5

**Global Environmental Negotiations-I (GEN-1)**  
**Green Politics**  
(Under reprint)

**Towards a Green World**  
Should Global Environmental Management be  
built on Legal Conventions or Human Rights?  
Paperback Rs. 200 US \$10

**The Price of Forests**  
Proceedings of a Seminar on the Economics  
of the Sustainable use of Forest Resources  
Hardbound Rs. 180 US \$22

**The Challenge of the Balance**  
Environmental Economics in India, Proceedings of the National  
Environment and Economics Meeting Hardbound Rs. 590 US \$22

**GLOBAL WARMING**  
**In an unequal World**  
A case of environmental colonialism Rs. 30 US \$6

**Children's Story Books**  
Chipko Rs. 20 US \$5  
The Chilika Lake adventure Rs. 65 US \$9

## STATE OF THE ENVIRONMENT SERIES

**The Curse of the White Gold (SOE Series-1)**  
Paperback Rs. 75 US \$7

**Protection of Nature Parks  
Whose Business? (SOE Series-2)**  
Paperback Rs. 75 US \$7

**Slow Murder: The Deadly Story of Vehicular Pollution in India**  
(SOE Series-3) Hardbound Rs. 390 US \$19  
Paperback Rs. 75 US \$7

**Homicide by Pesticides**  
What Pollution does to our Bodies (SOE Series-4)  
Paperback Rs. 75 US \$7

## WEALTH OF THE NATION VIDEO SERIES

**The Living Word**  
32 mins Pal VHS Rs. 750 US \$25

**Harvest of Rain**  
48 mins Pal VHS Rs. 750 US \$25

**Thar: Secrets of the Desert**  
52 mins Pal VHS Rs. 750 US \$25

**The Village Republic**  
50 mins Pal VHS Rs. 750 US \$25

Set of 4 cassettes Rs. 2,500 US \$90 Add Rs. 50 US \$20  
as postage and handling charge

**Our Ecological Footprint**  
(An Environment Education Manual for School Teachers)  
Rs. 90 US \$8

## DIRECTORIES

- **Natural Resource Links:** A Directory of Government departments and institutions dealing with India's natural resource  
Paperback Rs. 490 US \$18
- **Indo Gangetic Links:** A Directory of environmental experts in the Indo Gangetic Plains  
Paperback Rs. 65 US \$6
- **Health Links:** A Directory of experts on environmental health  
Paperback Rs. 65 US \$6
- **Water Links-2:** A Directory of individuals and organisations involved in water harvesting in India and overseas  
Paperback Rs. 140 US \$10

Payment for all foreign orders to be made ONLY by credit card or bank transfer to Account No.: 320143055 of Centre for Science and Environment at American Express Bank Ltd., Hamilton House, Block A, Connaught Place, New Delhi-110001 INDIA



## CENTRE FOR SCIENCE AND ENVIRONMENT

is a public interest research organisation dedicated to disseminate information about science and environment

41, Tughlakabad Institutional Area, New Delhi - 110 062 Tel: 91-11-608 6399, 608 3394, 608 1110

Fax: 91-11-608 5879 Email: sales@cseindia.org Website: www.cseindia.org

When the environment  
is polluted by  
trying to understand  
CSE came across so

Several...  
where government  
water.

These villages...  
monsoon and store it  
understood that...  
planners.

Further research  
for millennia. Ex...  
Thinking on water...  
paperwork. No projec

CSE came...  
report in the State...  
civil society's understand  
wasn't.

The immense s...  
water harvesting...  
mobilisation. The...  
President of India...  
harvesting that...  
km President's Estate  
installed the system

When the environment is degraded, the most vulnerable are the poor. Be it pollution by industry or drying up of water sources. It was while trying to understand the plight of the rural poor during the 1987 drought that CSE came across something that still escapes Indian policy-makers.

Several drought-affected villages of the mostly arid state of Rajasthan, where government relief was nowhere to be seen, were doing quite well for water.

These villages had traditional systems to harvest the little that rains during the monsoon and store it for times of scarcity. Time-tested systems. Traditions that understood that all water comes from rain, a simple fact that still eludes most water planners.

Further research revealed that India has had a plethora of such systems for millennia. Each one varied from the other, in accordance with local needs. Thinking on water was as decentralised as rainfall. All details worked out. No paperwork. No project proposals.

CSE came out with these findings in *Dying Wisdom*, the citizens' fourth report in the State of the Environment series. This marked a watershed in the Indian civil society's understanding of the water crisis. Or the creation of a water crisis that wasn't.

The immense success of *Dying Wisdom* led to a national conference on water harvesting with emphasis on technologies, policy and social mobilisation. The conference was inaugurated by K R Narayanan, the President of India. He was so impressed by the potential of rainwater harvesting that he instructed his officials to harvest rainwater for the 1.33-sq km President's Estate. CSE, along with a team of experts, has successfully installed the system in the Estate which captures 103 million litres of water

per year, as well as recharges the groundwater. Recommendations of the conference led to the formation of the National Water Harvesters' Network with CSE as the central secretariat. The network provides a common platform to those interested in finding a lasting solution to water scarcity.

The primary aim is to make the management of water everybody's business. To ensure that this management is not a centralised issue that the State has to deal with.

The network aims to promote water harvesting in both rural and urban areas. *Catch Water*, the network's bimonthly newsletter encourages people in cities and villages to catch rain where it falls. To decentralise water thinking. The network has also established Technical Services for designing rainwater harvesting systems in the urban sector.

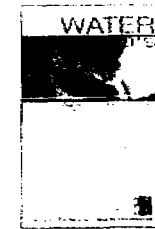
The rallying point of CSE's campaign on water management has always been decentralisation. That's why we created the slogan 'Make Water Everybody's Business'. We are happy to note that the World Water Commission found it meaningful and made it their slogan: *Make Water Everybody's Responsibility*.

Water is crucial. If we can manage it, the rest will follow. CSE has been very consistent in promoting good political efforts to manage water and pushing those who are yet to catch up. It is clear that good electoral future lies in sensible land and water management. At the same time, we highlight meaningful microexperiences sponsored by the communities and NGOs spreading the good word all the time.

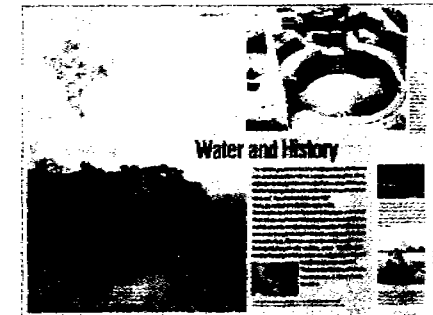
CSE urges everyone to join its endeavour to make water everybody's business. All over the planet.



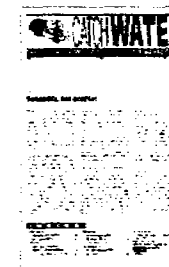
**Dying Wisdom:** Rise, fall and potential of India's traditional water harvesting systems.



**Water Links:** Comprehensive directory of water harvesters in India.



Posters series on traditional water harvesting systems of India.



**Catch Water:** Bimonthly newsletter of the National Water Harvesters' Network.



**Arvari:** Video on the science and economics of reviving a river in Rajasthan.