

2 1 2 . 0

8 3 G.R.

IRC
International Reference Centre
for Community Water Supply
and Sanitation

WHO Collaborating Centre

April 1988

Rijswijk (The Hague), The Netherlands

A Groundwater Primer

21

Technical Paper Series

2 12. 0-836R-1008

A Groundwater Primer / G.J. Heij, C.R. Meinardi –
Rijswijk, The Netherlands: International Reference Centre for Community Water Supply and
Sanitation (Technical Paper; 21).
With bibliogr., index.
ISBN 90-6687-003-6
UDC 556.3

ABSTRACT

An introduction is given to the basic principles of geohydrology, i.e. knowledge of the occurrence and the movement of groundwater. The subject is divided in six chapters. The first one deals with the place of groundwater in the hydrological cycle. In the second chapter the properties of ground and water are discussed and the geohydrological terminology is introduced. In the third chapter the theory of groundwater flow and simple examples of calculations and modelling are presented. The quality of groundwater, including fresh/brackish relations, is treated in the fourth chapter. The fifth one contains a review of various field and laboratory investigations and how to combine them. The last chapter deals with the possibilities and the constraints of groundwater development at regional and at local scale.

Keywords: hydrogeology / hydrological cycle / groundwater / water quality / flow / groundwater survey / water resources development.

INTERNATIONAL REFERENCE CENTRE FOR COMMUNITY WATER SUPPLY AND SANITATION

IRC is an internationally operating organization dealing with information and technology support for water and sanitation improvement.

With its partners in developing countries and with the United Nations agencies, donor organizations and Non-Governmental Organizations, IRC assists in the generation, transfer and application of relevant knowledge. The focus of this cooperation is on rural and urban-fringe areas where the need for technical assistance is greatest.

IRC's information-oriented programmes include: 1. Information Support and Services; 2. Technology Development and Transfer; 3. Manpower Development and Training; 4. Community Education and Participation; 5. Programme Planning and Evaluation.

Support is provided by means of publications and training material, seminars and courses, research and demonstration projects, as well as by advisory support to the development of national facilities.

Requests for information on IRC should be addressed to IRC, P.O.Box 5500, 2280 HM Rijswijk, The Netherlands.

INTERNATIONAL REFERENCE CENTRE
FOR
COMMUNITY WATER SUPPLY
AND SANITATION

22 3656

212.0

83GR

wh 1008

A GROUNDWATER PRIMER

G.J. Heij
C.R. Meinardi

1979
International Reference Centre
for Community Water Supply

Technical Paper no. 21

National Institute for Water Supply
P.O.Box 150
2260 AD Leidschendam, The Netherlands

I.R.C.
P.O.Box 5500
2280 HM Rijswijk, The Netherlands

Copyright © by the International Reference Centre for Community Water Supply and Sanitation.

IRC enjoys copyright under Protocol 2 of the Universal Copyright Convention. Nevertheless, permission is hereby granted for reproduction of this material, in whole or part, for educational, scientific, or development related purposes except those involving commercial sale **provided that** (a) full citation of the source is given and (b) notification in writing is given to IRC, P.O. Box 5500, 2280 HM Rijswijk, The Netherlands.

contents

Introduction	1
1. <u>The hydrological cycle and the water balance</u> : precipitation; evapo-transpiration; surface water runoff; groundwater flow; water balances.	2
2. <u>Properties of ground and water</u> : water, rocks; geology, hydrogeology, geohydrology, heads; Darcy's law; permeability; groundwater flow; transmissivity; hydraulic resistance; storativity.	13
3. <u>Determination of groundwater flow patterns</u> : methodology; Darcy's law in general form; continuity; boundary conditions; analytical solutions for steady flow; approximate methods; analogue methods; numerical methods; superposition; unsteady flow.	32
4. <u>Groundwater quality</u> : quality and use; components of water quality; main processes; sources of brackish or saline groundwater; physical phenomena; behaviour of brackish groundwater.	55
5. <u>Groundwater surveys</u> : use of available data; field and laboratory investigations; head observations; geophysical soundings; pumping tests and single well tests; analysis of pumping tests.	76
6. <u>Groundwater development</u> : resources and demand; regional development, maximum withdrawal and constraints; local scale development; design of pumping wells, yield of wells.	97
Appendix A. Conversion factors for some much used units in (geo)hydrology as to ISO standards	116
Appendix B. Further reading	118



introduction

In 1982 this primer, which was published in IRC's Occasional Paper Series, was in high demand from developing countries as well as the western world. To make this valuable information available to a wider audience IRC decided to reprint the Groundwater Primer (with a few corrections) in its Technical Paper Series.

With the present notes the authors intend to give you an introduction to the basic principles of geohydrology. Geohydrology deals with the occurrence and the movement of groundwater. Their purpose is to discuss every major topic briefly, giving the principles, but without going into detail. They do not aim at making a geohydrological expert of you; merely you should be able to understand such a specialist. If you ever work in a team with a geohydrologist, you will need some knowledge of what he is doing and why, or else the team will not function optimally. We would be happy if this primer could be of help to you in this respect.

Nevertheless, you might find yourself some day in a position where you alone have to solve some simple geohydrologic problem. We hope that in such cases this primer, if not leading you to the perfect solution, may anyhow help you to avoid the most obvious pitfalls.

In the addendum we noted some titles for further reading.

I.R.C.,
Rijswijk,
March 1983.

1.

the hydrological cycle and the waterbalance

1.1. general remarks

Almost all the water on earth participates in a continuous movement, the so-called hydrological cycle.

River flow to the sea shows the existence of this cycle. No resulting rising of sea level occurs and the rivers do receive water again and again. Evidently, a return flow of water exists from the sea to the sources of the rivers. Ocean water is transformed into vapour (this is called evaporation) and because evaporation exceeds the amount of rainfall, vapour-transport takes place through the atmosphere to the continents. Evaporation occurs above the sea as well as at the land-surface. Mostly, however, at land the rainfall will exceed evaporation. The sun yields the energy to sustain the cycle.

Hydrology deals with the occurrence and flow of water. Geohydrology concerns especially the groundwater part of the hydrological cycle.

Figure 1 shows the hydrological cycle in a schematical way. The main components are rainfall or precipitation (P), evapotranspiration (E), surface runoff (R) and groundwater flow (Q); in the next pages they will get some further attention.

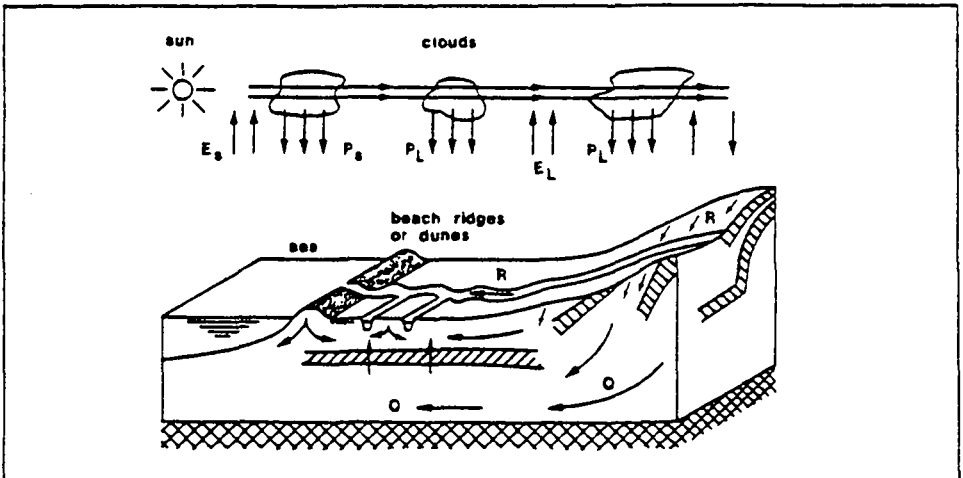

Fig. 1.1.

The hydrological cycle

The long-term cycle of the world's water shows the following quantities:

Land surface of the earth ($136 \times 10^6 \text{ km}^2$):

$P_L = 101\,000 \text{ km}^3/\text{year} = 750 \text{ mm/year}$ (average precipitation);

$E_L = 74\,000 \text{ km}^3/\text{year} = 545 \text{ mm/year}$ (average evaporation);

$R = 27\,000 \text{ km}^3/\text{year} = 205 \text{ mm/year}$ (average surface runoff to the sea);

$Q =$ very small, compared with R (groundwater flow to the sea).

Sea surface of the earth ($374 \times 10^6 \text{ km}^2$):

$P_S = 324\,000 \text{ km}^3/\text{year} = 870 \text{ mm/year}$ (average precipitation);

$E_S = 351\,000 \text{ km}^3/\text{year} = 940 \text{ mm/year}$ (average evaporation);

$R = 27\,000 \text{ km}^3/\text{year} = 70 \text{ mm/year}$ (inflow of surface water from land).

The vapour flow in the atmosphere from sea to the continents approximately equals R .

1.2. precipitation

1.2.1. general remarks

The vapour of the atmosphere precipitates mainly on the earth as rain, snow or hail. Clouds (suspended water drops) are an intermediate stage.

Rainfall is extremely variable in time and space. Even within a relatively small area (some km^2) rainfall can differ markedly from place to place.

- Mountains have a great influence on the amount of rainfall; rainfall increases strongly with height (orographic effect).

- In small areas along coasts generally less rainfall precipitates than further land-inward.

The amount of rainfall falling on the ground surface during a certain period is expressed as a depth (P , volume per surface area, in mm's), to which it would cover a horizontal plane on the ground.

1.2.2. measuring rainfall

Rainfall is measured with rain gauges, which are provided with a receiver, having a horizontal opening of known area (see fig. 1.2). The caught volume of water, V , is determined and P is calculated by dividing this volume by the receiving surface, A . In principle, any open receptacle (bucket) may serve as a rain gauge. Non-recording gauges or pluviometers are observed by periodical reading of the

accumulated rainfall. Self-recording gauges or pluviographs give continuous recordings of the rain being caught.

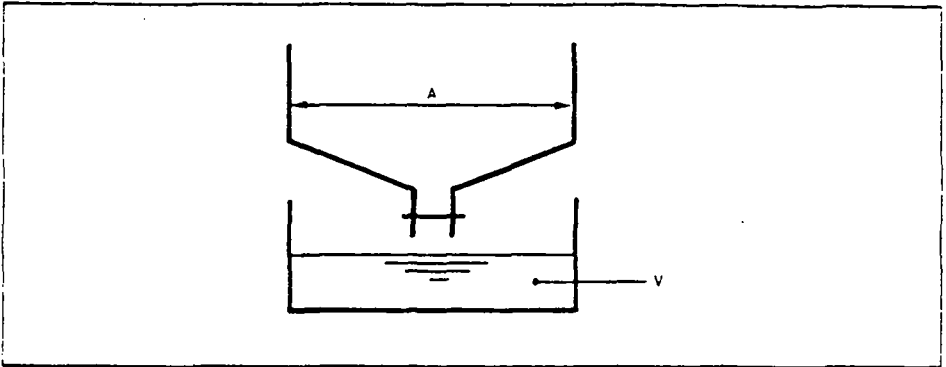

Fig. 1.2.

A rain gauge

Although the principle of measuring rainfall is relatively simple, it is sometimes difficult to obtain accurate measurements. Several disturbing factors may cause unreliable observations.

* The wind shelter effect.

The shelter effect occurs if the rain gauge is located too near a house, a tree, etc. The World Meteorological Organization gives as a rule of thumb that the gauge should not be closer to surrounding objects than about 4 times the height of these objects.

* The wind deformation effect.

The wind deformation effect is due to the fact that high wind velocities reduce the amount of rain caught in the receiver (turbulence effects etc., due to the construction of the rain-gauge itself). It has been observed that wind can reduce the catch by more than 10%. The height of the mouth of the receiver above the ground should be as low as possible because the wind velocity increases with height, but should be high enough to prevent splashing in. The deformation effect can further be reduced by choosing the site carefully (wind velocity has to be as low as possible and airflow across the mouth horizontal).

* Evaporation losses.

Evaporation losses are likely to occur in hot and dry climates. They can be reduced by putting some oil in the receiver and by measuring the amount of rainfall directly after precipitation.

* Vandalism.

Attention should be paid to prevention of vandalism.

* Storage capacity of the gauge.

Evidently the storage capacity of the gauge has to be sufficient in relation to the frequency of observation.

1.2.3. methods to determine from point measurements the average rainfall on an area

The required network density of rain gauges depends on the areal variability of rainfall and the desired accuracy. As rainfall in mountainous areas is more variable (orographical effects) than in flat areas, the network density has to be higher in the first case.

A rainfall measurement is a point observation and may not a priori be used as a representative value for the area under consideration.

How can we get the average rainfall of a total area from measurements at a given number of rain-gauges? The following methods are available (with possibilities and constraints mentioned):

1. Arithmetic average of rainfall depths at all rain gauges:

$$\bar{P}_A = \frac{P_1 + P_2 + P_3 + \dots + P_n}{n}$$

\bar{P}_A = average rainfall for the total area (mm);

n = number of rain gauges.

This is the most simple method, only to be used in a relatively flat area, where the gauges are evenly distributed (thus being equally representative).

2. The Thiessen method. This method assumes that the recorded rainfall in a gauge is representative for the area half-way to the adjacent gauges. Each observation point is connected with its adjacent points by straight lines; the half-way perpendiculars of these lines form a pattern of polygons (see fig. 1.3). The area for which a gauge is considered to be representative, is the area of its polygon and this area is used as a weight-factor for its rainfall. The sum of the products of areas and amounts of rainfall is divided by the total area covered by all gauges, to get the weighted average rainfall:

$$\bar{P}_A = \frac{P_1 A_1 + P_2 A_2 + \dots + P_n A_n}{A}$$

A_1 = area (polygon) around rain gauge 1;

A = total area.

Example (see also fig.1.3)

Observed rainfall (mm)	Area* (km ²)	Weighted rainfall
0.6	7	0.01
1.4	120	0.27
2.0	109	0.35
2.8	120	0.54
1.5	20	0.05
3.0	92	0.44
5.2	82	0.68
4.5	<u>76</u>	<u>0.55</u>
	$A = 626$	$\bar{P}_A = 2.89 \text{ mm}$

* Area of corresponding polygon within boundary

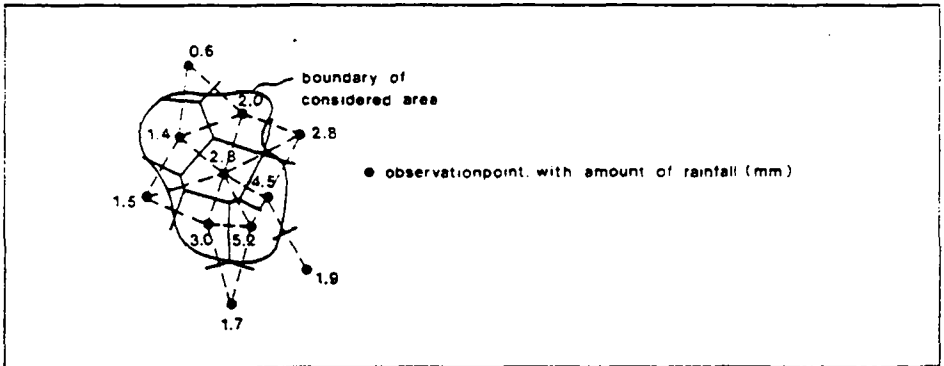

Fig. 1.3.

The Thiessen method

The Thiessen method can be used with good results when the rain gauges are not evenly distributed over the area. The method is rather rigid; if one gauge observation is missing or an extra observation point becomes available, you have to construct a new polygon network and to determine again the surfaces of the areas.

3. The isohyetal method. When the rainfall is unevenly distributed over the area, for instance due to orographic effects, the isohyetal method may be applied to

compute the area rainfall. This method consists of drawing lines of equal rainfall depth (isohyets), by interpolation between observed rainfall depths at the observation points (see fig. 1.4). Any additional information about the area may be used to draw the isohyets (e.g. contours of land surface).

$$\bar{P}_A = \frac{P_{1,2} A_{1,2} + P_{2,3} A_{2,3} + \dots}{A}$$

$P_{1,2}$ = rainfall between isohyets 1 and 2;
 $A_{1,2}$ = area enclosed by successive isohyets.

Example (see also fig.1.4)

Isohyet	Rainfall between isohyets	Area*	Weighted rainfall
5	5.1	13	0.11
4	4.5	77	0.55
3	3.5	116	0.65
2	2.5	196	0.78
1	1.5	193	0.46
< 1	0.9	<u>31</u>	<u>0.04</u>
		A = 626	$\bar{P}_A = 2.59$ mm

* Area enclosed by successive isohyets within boundary

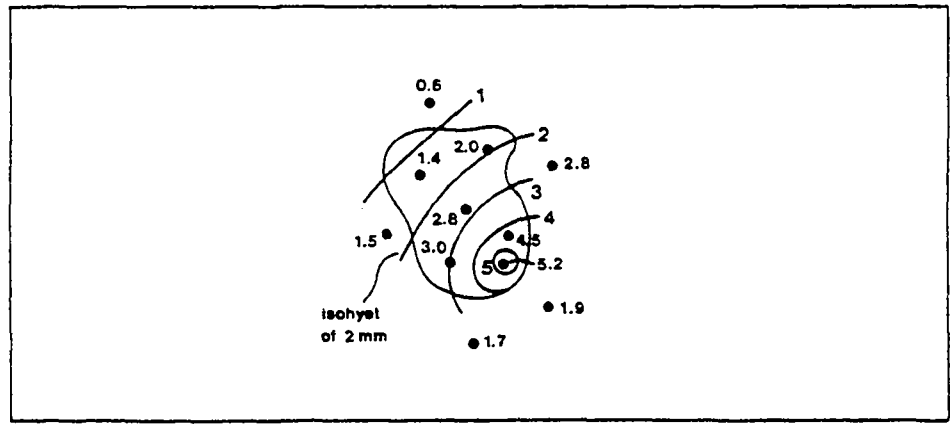

Fig. 1.4.
 The isohyetal method

The area rainfall \bar{P}_A is computed from the weighted average of average rainfalls between two isohyets (the weight being the enclosed area between the isohyets). The reliability of this method depends on the accuracy with which the isohyets can be drawn.

1.3. evapotranspiration

1.3.1. general remarks

Generally, a considerable portion of the rainfall does not flow to the surface-water, but evaporates again. This evaporation mainly takes place during daytime because the process needs sunlight (energy).

The following terms are relevant and need to be defined:

- * evaporation; this is the vapour transport from a wet surface (open water, wet vegetation, bare soil surface) to the atmosphere;
- * transpiration; this is the vapour transport from transpiring vegetations to the atmosphere;
- * evapotranspiration = evaporation plus transpiration;
- * open water evaporation = the evaporation rate from a free water surface (E_0);
- * potential evapotranspiration (E_{pot}); this is the maximum amount of vapour which might be transferred to the atmosphere under the existing meteorological conditions (water is not a limiting factor);
- * actual evapotranspiration (E_{act}); the actual amount of vapour transferred to the atmosphere depends also on the availability of water to meet the atmospheric demand.

1.3.2. estimation of evapotranspiration

Direct measurement of evapotranspiration is difficult, because we have to deal with vapour transport instead of water flow. In an indirect way a rough estimate is possible by means of a water balance of an area (see also 1.6). If all other terms of the water balance are known, E_{act} can be found by subtracting total inflow and outflow. In general the so-found E_{act} has a low degree of accuracy. Much more intricate is the use of models to calculate evapotranspiration. This includes mathematical simulation of the process of moisture transport and storage in the subsoil and the crop (Penman-equation etc.). For these methods you need many data.

There are several empirical methods which give you more or less insight into the magnitude of evapotranspiration in some area. Turc derived from the data of many river basins the following empirical formula:

$$E_{act} = \frac{P}{\sqrt{0.9 + \frac{P^2}{E_{pot}^2}}} \text{ (mm/year)}$$

This formula gives a rough estimate of the evapotranspiration over a year. To determine E_{pot} you can take as a good approximation:

$$E_{pot} = 325 + 21t + 0.9t^2 \text{ (mm/year)} \quad (\text{Langbein})$$

t = average temperature over the year ($^{\circ}\text{C}$)

The following remarks can be made about Turc's formula:

- * if $P \ll E_{pot}$, then holds: $E_{act} = P$ and there is no discharge;
- * if $P \gg E_{pot}$, then it follows, that $E_{act} = E_{pot}$.

1.4. surface runoff

Rainfall on the soil surface schematically is discharged in two ways (see fig. 1.5).

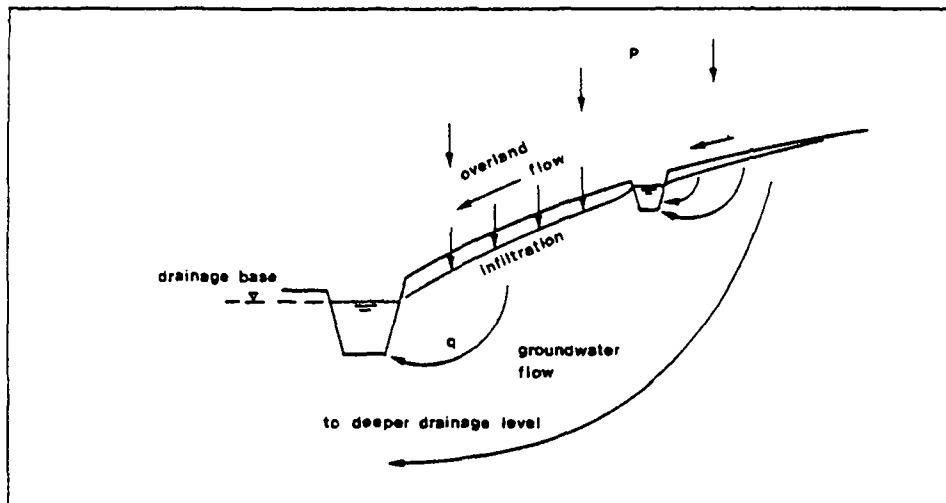

Fig. 1.5.

Discharge of rainfall

- a. Flow at or just below land surface (overland flow and interflow). This water flows directly to the surface water and thus limits replenishment of the groundwater.
- b. Infiltration into the subsoil. A part of this amount serves as a supply to the moisture content and the other part flows to several drainage systems, on several levels. This is the groundwater flow.

The foregoing is the reason that you can distinguish two main components in river flow: a (more or less) constant base flow and a fast component (direct runoff). At long dry periods the base flow will decrease. See figure 1.6..

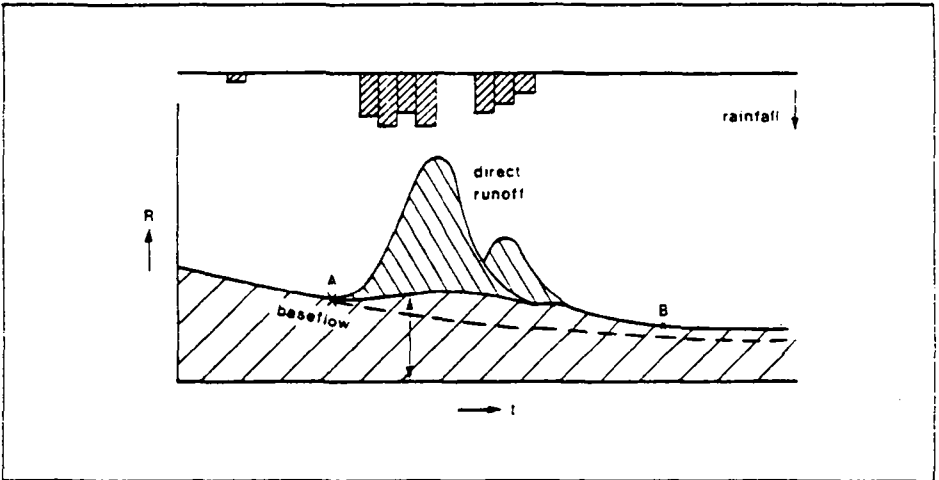

Fig. 1.6.

Groundwater and surface runoff components in river discharge

When the time-discharge graph (hydrograph) of fig. 1.6 is known, you may distinguish between base flow and direct runoff. You have to determine points A and B and to connect those points by a smooth line. A is the discharge at the end of a dry period and B after a period of rainfall. B may be found by backward extrapolation from the subsequent dry period (extrapolation along an exponential function). All discharge above the line AB represents direct runoff and the below discharge is baseflow.

Surface runoff can occur in a natural way, through rivers, brooks etc. (free discharge). The second possibility is artificial discharge; in this case energy has to be added to bring the water where you want to have it. Mostly a closed system of drains and collecting ditches is constructed, the whole system constitutes a polder.

1.5. groundwaterflow

The geological composition of the subsoil has an important influence on the part of the hydrological cycle that is located in the ground: groundwater flow. All kinds of rocks consist of solid material (rock or sand grains) and pores. In the saturated zone - the groundwater zone - there is no air in the pores. Mostly the pores are interconnected and so groundwater flow can occur. The phreatic level is the level where waterpressure equals airpressure. Above this level the water has a negative pressure (suction) and there the pores are only partially filled with water; capillary forces cause the soil to contain water above the phreatic level. Flow of this water is mainly vertical.

The lower boundary of the saturated groundwater zone is badly defined in most cases. Even at very large depths you may find some water in open spaces. For practical purposes, however, mostly you have to assume a practically impervious base of the groundwater zone, under which the flow of groundwater may be omitted. In other words, this water does not take part in the hydrological cycle. The flow of groundwater implies that it is recharged in certain areas and discharged in others.

Groundwater recharge may take the form of percolating rainfall or infiltrating rivers or other surface water. Artificial or induced recharge from man-made ponds, canals or even wells is sometimes practised. Groundwater discharge is in the form of drainage by brooks, rivers, ditches and drains etc., or in the form of upward seepage to swamps or low-lying polders. At natural springs the discharge of groundwater of larger areas is concentrated at one location.

1.6 the waterbalance

Generally, the study of the hydrological cycle applies to an areally restricted area. Often, you are interested in the order of magnitude of the several components of the cycle in such an area. In that case a so-called water balance can be drawn up. This is an evaluation of in- and outflowing amounts of water within the studied area; for groundwater a volume of underground is taken. In the stationary situation (equilibrium) inflow equals outflow. In the non-stationary situation the water balance has to be in equilibrium too, but in that case we have to take into account extra storage of water.

All components of the hydrological cycle are interrelated: the changing of one component has its influence on the others. Study of the hydrological cycle and

the mechanism of flow within the cycle can give us insight into the consequences of an interference (e.g. withdrawal of groundwater) that we initiate in the cycle of the water in an area

Generally, all water balances have the following form:

$$\text{INFLOW} = \text{OUTFLOW} + \text{EXTRA STORAGE.}$$

Elaboration for groundwater volumes yields:

$$(P-R)+I+AR+Q_{in} = E + D + Q_{out} + W + S$$

where

- P-R = precipitation - direct runoff;
- I = infiltration from surface water;
- AR = artificial recharge;
- Q_{in} = groundwater inflow;
- E = evapotranspiration;
- D = drainage (including upward seepage);
- Q_{out} = groundwater outflow;
- W = withdrawals;
- S = extra storage.

Depending on each particular situation you may omit one or more terms of the balance equation. Anyhow you have to define the balance period. For longer periods the amount of extra storage will become relatively small and may be omitted.

2.

properties of ground and water

2.1. general

Groundwater is water in the underground. Hence, if you have to deal with groundwater, then both the properties of ground and of water are important. We will treat some properties of ground and water, insofar as they are relevant to the occurrence and the flow of groundwater. A systematic description of the structure of the underground is given in geology. Hydrogeology is a branch of geology dealing specially with the occurrence of water in the underground.

The terminology used in hydrogeology is also of prime importance to the geohydrologist. Geohydrology is dealing also with the occurrence and especially the flow of groundwater, but now approaching it as the underground part of the hydrological cycle. Clearly hydrogeology and geohydrology will overlap a great deal.

The flow of groundwater, being a physical phenomenon, can be represented by mathematical formulation. The basic law governing practically all flow of underground water is Darcy's law. In trying to quantify hydrological processes in the underground the geohydrologist has developed his own terminology. Partly these terms belong to the energy conditions of the groundwater, mostly expressed as groundwater heads. Partly the geohydrologic behaviour of various rocks types is concerned.

In this chapter we will introduce to you mainly the physics of groundwater. We will treat the chemistry of underground water in a separate chapter.

2.2. properties of water

2.2.1. *dissolution capacity*

Water is a very good solvent. The chemical compound H_2O may contain a great lot of other chemical constituents. The pure form of the H_2O does not occur in nature, it will always have other compounds in solution. This is the subject of the quality of groundwater, later to be treated in more detail.

2.2.2. density

The density of water is related to temperature. Water will have its greatest density, 1000 kg/m^3 , at 4°C (see table 2.1.). At other temperatures water will be lighter, even after freezing. For this reason ice floats on water. Furthermore density is affected by the quantity of dissolved components. Saline water is heavier than fresh water. In many situations a layer of fresh groundwater may float upon more saline groundwater. The relations between fresh and saline water in the underground again will be treated separately.

2.2.3. viscosity

The fluid water has a certain viscosity. Viscosity is the parameter indicating the ease of flow of a fluid or a gas. The greater the viscosity the less fluid a fluid is. Air has a smaller viscosity than water. Viscosity is related to temperature for one type of fluid. See tabel 2.1. The ease of flow of groundwater through the pores of the underground (permeability) depends on viscosity.

Table 2.1.

Relation between temperature and density and viscosity for fresh water

Temp. in $^\circ \text{C}$	0	4	5	10	15	20
Density in kg/m^3	999.868	1,000.000	999.992	999.727	999.126	998.230
Dyn.visc. in $\text{kg.m}^{-1} \cdot \text{s}^{-1}$	1.79×10^{-3}		1.52×10^{-3}	1.31×10^{-3}	1.14×10^{-3}	1.01×10^{-3}
Kin.visc. in $\text{m}^2 \cdot \text{s}^{-1}$	1.79×10^{-6}		1.52×10^{-6}	1.31×10^{-6}	1.14×10^{-6}	1.01×10^{-6}

2.2.4. heat retention capacity

Water has a great capacity to store heat. The reason is that specific heat retention is high (the amount of heat needed to warm up 1 gram of water with 1°K), but also the amount of heat needed for melting and for evaporation is high. The consequence for groundwater is that it will have a fairly constant temperature, which more or less will equal the annual average of air temperature.

More generally, the high heat retention capacity of water has a dampening effect on climatic changes at the earth.

2.3. properties of rocks

The major difference in rocks is between solid rocks, also called hard rocks, and unconsolidated or soft rocks, composed of granular elements. Examples of solid rocks are granites, sandstone and limestone. Soft rocks are sand, clay, peat etc.

Almost every rock will contain void space, which can be filled with water but also with gasses, with oil etc. In hard rock the largest voids may have the form of crevices along cracks, or solution channels. In soft rocks the major voids are the pores which occur between the grain structure. Some hardrocks may contain both cracks and pores in significant amounts, such as e.g. some kinds of limestone. Generally the hard rocks will contain little open space, they will not contain much water and mostly have a limited transmitting capacity for water flow. Nevertheless under favorable conditions some water may be derived even from the hardest rocks like granites, diorites etc. For our purpose, however, the unconsolidated rocks and notably sand and clay, are the most important.

Sandlayers in the underground are very important in hydrogeology as they mostly have a good waterbearing capacity, implying that water can be withdrawn from it in significant quantities. Clay mostly does not have good waterbearing capacities; it contains sufficient water, which, however, cannot easily be withdrawn. Clay is still important because in many situations it will act as a twin brother to sand. Where sand layers occur, clay layers may confine them and thereby will influence the hydrologic properties of the sand layers.

Intrinsic properties of sand and clay in the field are:

- grain size distribution;
- packing - the way the grains are packed in the grain structure;
- sorting of the grains - indicating the uniformity of the diameters of the grains;
- porosity - the percentage of open space between the grains.

For average grain size the following subdivision is often followed:

- silt - diameter smaller than 0.050 mm;
- fine sand - diameter in between 0.050 and 0.2 mm;

- coarse sand - diameter between 0.2 and 2 mm;
- gravel - diameter between 2 and 64 mm;
- cobbles - diameter larger than 64 mm.

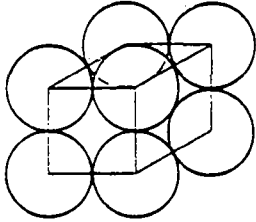

a) Large spherical grains in cubic packing (theoretical situation)
porosity = 0.48 large permeability

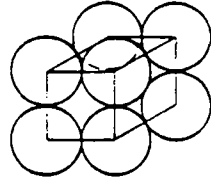

b) Small spherical grains in cubic packing (theoretical situation);
porosity = 0.48 smaller permeability than at case a.

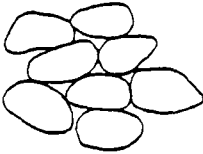

c) Well - sorted, natural, clean sand
porosity = 0.35
loosely packed
good permeability

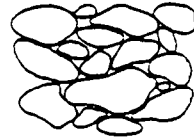

d) Badly sorted sand with about the same average grain size, smaller porosity, more consolidated and less permeable than case c.

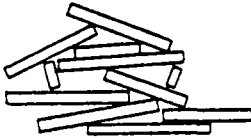

e) Clay particles in plate-form
loosely packed
high porosity
low permeability



f) Clay particles in plate-form
strongly compacted
low porosity
very low permeability

Fig. 2.1.

Grain size, packing, sorting and permeability of sand and clay

Packing, sorting, and porosity are illustrated in figure 2.1. In this figure indications are also given as to permeability. Permeability is the parameter of a soil or ground body which indicates the ease of flow of a fluid through it. Permeability is related to the above characteristics of rocks, but cannot directly be derived from it. Nevertheless it is a parameter which is of paramount importance in geohydrology. The significance of permeability and the way to determine it in the field will receive much attention in the following chapters.

2.4. geology

2.4.1. the use of geology

Geology is of great value to the geohydrologist, because it will indicate to him the extent of water bearing layers and less pervious layers, both in horizontal and in vertical direction. The geologist uses two major divisions: chronostratigraphy is based on the age of rocks; lithostratigraphy on common lithological features (lithology describes the composition of rocks).

Mostly the first division to be made by a geologist is to determine the chronostratigraphical sequence of layers. This will already give some indication as to lithological differences. The geologist will know about the geological processes prevailing during certain periods of geological history and thereby can make a guess about the type of rock formed. A more refined subdivision can thereafter be made in geological formations, leading to a lithostratigraphical sequence.

2.4.2. lithology

With regard to genesis three major types of rocks can be distinguished:

- 1. Igneous and volcanic rocks, formed at the solidification of molten material risen from the interior of the earth. Volcanic rocks may be intrusive, that is solidified below land surface or extrusive if solidified at land surface. Intrusive rocks mostly have poor water-bearing properties. Their porosity is low and they are mostly practically impermeable. Examples are granite and diorite. Extrusive rocks may sometimes have better qualities. Examples are basalt, which may form water-bearing layers due to crevices formed along cracks and some types of granularly deposited lava.
- 2. Sediments originating from weathering (crushing) of previously formed rocks, subsequent erosion (transport) and deposition at another location. Examples

are sand, clay and limestone. Many sediments form excellent water-bearing layers. Sediments can again be distinguished:

- terrestrial sediments - deposited at land;
- marine sediments - deposited at sea;
- fluvial sediments - transported by rivers;
- eolian sediments - transported by air;
- organogenic sediments - formed by organic life.

Not all sediments are unconsolidated rocks. Sandstones and conglomerate are cemented forms of sand and gravel. As such their porosity and hence their permeability will be reduced. Also limestone is a consolidated sediment, having sometimes a high permeability due to solution channels.

- 3. Metamorphic rocks, originating from one of the previous types of rocks put to high pressure and high temperature. Practically all metamorphic rocks have very poor water-bearing qualities. Only where metamorphic rocks have been exposed to weathering, some fractures may have widened to crevices containing groundwater in appreciable quantities.

2.4.3. *some important geologic processes*

A number of geologic processes will influence the occurrence and flow of groundwater, such as:

- Faulting

In hard rocks faulting may cause crushed zones, which have a higher porosity and permeability than the surrounding rocks. Such zones may be used for the withdrawal of groundwater. In soft rocks, sometimes the opposite occurs. Due to smearing action of faulted clay layers a fault may act as a barrier to groundwater flow in adjacent layers.

- Marine transgressions

Coastal zones mostly will have a complex history of transgressing and receding seacoasts. During a transgression the underground covered by seawater may become salinated and the groundwater brackish. It will take a long time after regression to flush the salt water away.

- Forming of river valleys

The erosive action of surface water is enormous. The products of erosion will accumulate alongside rivers. Dependent on flow velocity coarser or finer

material will come to rest. Thereby alluvial plains will show sometimes a complex alternation of sand and clay layers, both vertically and horizontally.

2.4.4. hydrogeology

Water is one of the components of the underground and the hydrogeologist has specialized in the description of the occurrence of groundwater.

A first classification concerns the environment in which groundwater is present. Three major types of groundlayers can be distinguished:

- 1. An aquifer, or a water bearing layer is a layer, able to allow transport of appreciable quantities of water under field conditions. Sand layers mostly are good aquifers.
- 2. An aquiclude is a non-permeable layer which may contain water but is incapable of transmitting significant quantities of water.
- 3. An aquitard is a less permeable layer, again not capable of transmitting water in a horizontal direction, but allowing considerable vertical flow. Clay layers are examples of aquitards.
- 4. An aquifuge is an impermeable ground body neither containing nor transmitting water. Granite layers may act as aquifuges.

A further description can be made as to the pressure conditions of the groundwater concerned (see fig. 2.2.). A first division is:

- a. Soil moisture, present in layers above the phreatic level. At the phreatic level the groundwater pressure just equals barometric pressure. Groundwater above the phreatic level will have a lower pressure than air pressure. Equilibrium between gravitational and capillary forces holds that water at its place. It may be subdivided in capillary water, present in a zone where water in the ground pores is interconnected and in pendular water present in separated smaller pores.

- b. Saturated groundwater below the phreatic level or water table.

With saturated groundwater all pores are fully filled with water. Saturated groundwater may be subdivided in a number of categories (see figure 2.3.).

- b.1. If the phreatic level is situated within an aquifer then the saturated groundwater is called phreatic. The aquifer is called unconfined.
- b.2. Groundwater may be under pressure conditions in a confined aquifer. The aquifer is covered by a confining layer situated below the water table. The piezometric level of the groundwater in a confined aquifer is the

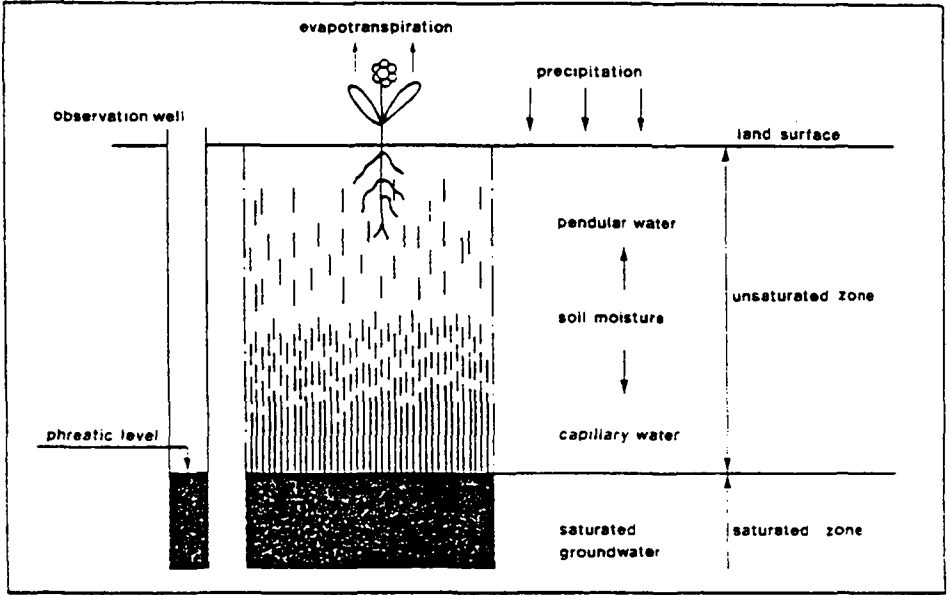

Fig. 2.2.

Terminology of shallow groundwater

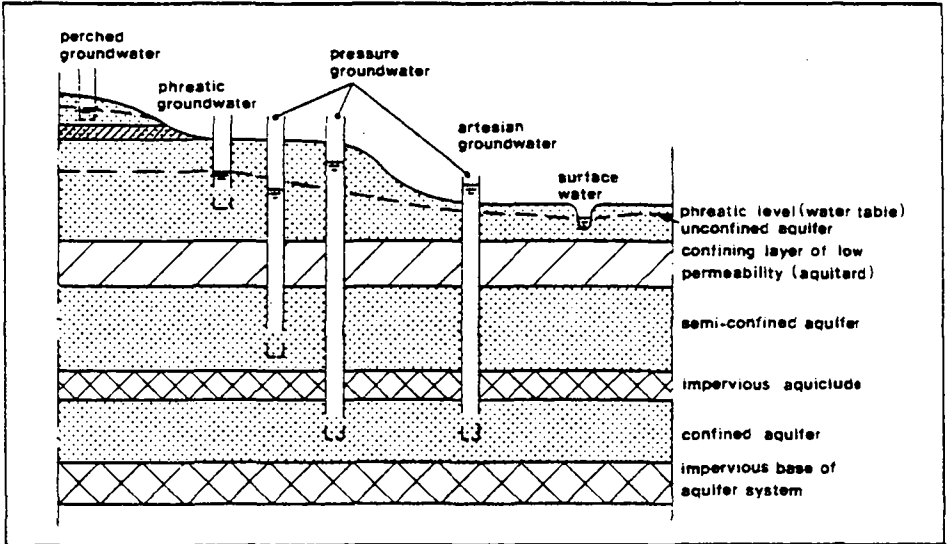

Fig. 2.3.

Terminology of deep groundwater

level to which the groundwater will rise in an open standpipe with a screen in the aquifer. This piezometric level may be above or below the phreatic level in an unconfined aquifer above the aquifer concerned.

Confined aquifers may be divided in semi-confined and fully confined aquifers dependent on the permeability of the confining layers above and below. If both layers are practically impermeable, the aquifer is fully confined.

The pressure in a confined aquifer may be such that the piezometric level rises above the land surface. Wells in the aquifer will be free flowing. The groundwater is called artesian in such a situation.

- b.3. Sometimes above a deep water table, a clay layer may be present above which again a groundwater body has developed. These two water tables will be situated above each other. The upper aquifer is called a perched aquifer.

2.5. geohydrology

2.5.1. flow of groundwater

Geohydrology is the branch of hydrology dealing with the underground part of the hydrological cycle. A good description of groundwater as given in hydrogeology is crucial, but in addition the flow of groundwater is especially studied by the geohydrologist.

The flow of groundwater mainly depends on three factors:

- Differences in energy conditions within the groundwater.
- Permeability of the underground.
- Density of the groundwater.

In most cases the problems concerning groundwater flow are restricted to fresh groundwater and in that case density differences are negligible. Therefore we will not discuss the effect of density on flow, but we will focus on energy conditions, as expressed by heads and on permeability.

2.5.2. groundwater heads

Groundwater flow requires energy due to frictional losses. Hence, a source of energy is needed. The moving forces behind groundwater flow result from differences in potential energy. In fresh groundwater, variations in density are very small and in such cases the potential energy of the groundwater is linearly

related to the head, being an expression of place and pressure. The potential energy of fresh groundwater at a certain location can conveniently be represented by the head of the groundwater at that place.

The head of groundwater should always be related to a reference level and then the following definition holds (see also fig. 2.4.).

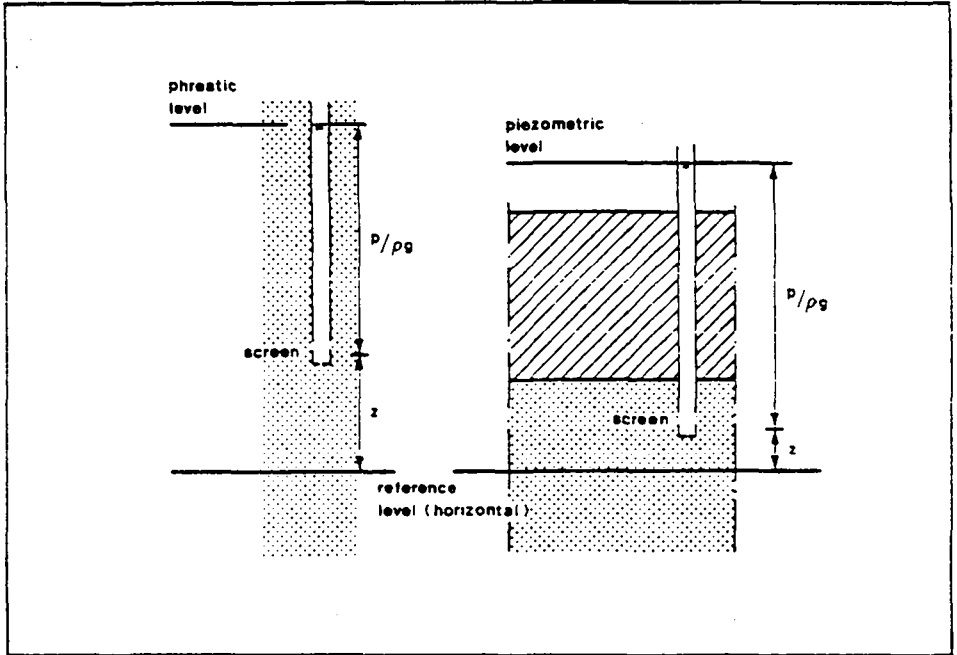

Fig. 2.4.

Determination of groundwater head for unconfined and confined groundwater

The head of groundwater in a certain point equals the sum of the height of that point above reference level plus the height of a column of water being in equilibrium with water pressure at that point.

In formula: $h = z + P/\rho g$

h = the head in a certain point, in m;

z = height of the considered point, in m;

p = water pressure, in Pa = $\text{Nm}^{-2} = \text{kg} \cdot \text{m}^{-1} \cdot \text{s}^{-2}$;
 g = acceleration of gravity, in $\text{m} \cdot \text{s}^{-2}$;
 ρ = density, in $\text{kg} \cdot \text{m}^{-3}$.

For fresh groundwater holds:

Fresh groundwater flows from points with high head to points with lower head;
between points of equal head no flow occurs.

A plane in the underground containing only points of equal head is called an equipotential plane. In aquifers very often the flow of groundwater is practically horizontal. In such a situation, according to the above definition no differences in head can exist along a vertical line; the pressure distribution is called hydro-static. This means that the equipotential planes in such an aquifer are vertical and that they can be plotted as lines on a map. Such lines are called groundwater contours or (groundwater) isohypses (see figure 2.5.).

No flow component can exist along isohypses, again according to the above definition. Hence, the flow of groundwater is perpendicular to the groundwater contours. Isohypses and flow lines intersect at right angles. Hence, the direction of groundwater flow follows straight forwardly from a map of groundwater contours.

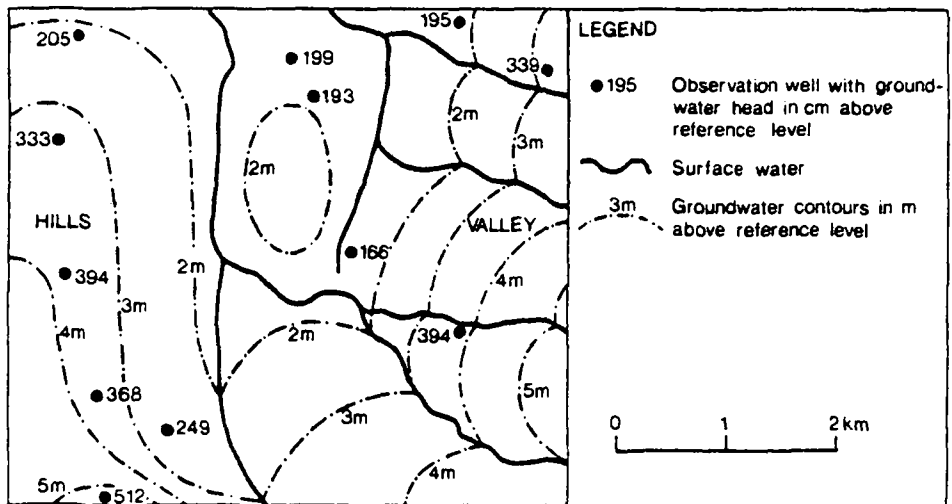

Figure 2.5.

Example of a groundwater contour map

Generally, groundwater heads will fluctuate in time, mainly due to changes in recharge and discharge, but sometimes also due to changes in pressure conditions. Shallow groundwater heads are directly related to recharge; they will be low after periods of drought and high after rainy periods. Mostly you may observe seasonal fluctuations as well as year-long changes in head. In areas with excessive pumping the heads may continuously go down.

Head changes in confined groundwater are firstly caused by pressure fluctuations; these may be due to recharge/discharge variations at other places but also e.g. to barometric changes, to tides in surface water, to earthquakes, etc.

Sometimes the absolute values of the groundwater head are important, e.g. when you have to pump groundwater with a suction pump at land surface, you need to know the lowest possible level below surface. On the other hand if you want to compose isohypses, then you need either average values, or you may take values of one particular day, assuming that the fluctuations will be similar for all observation points. A practical problem with groundwater contours is, that all heads should be related to the same reference level.

2.5.3. Darcy's law

The friction exerted by a ground volume to flow of groundwater may be expressed in terms of resistance to flow or its reciprocal value, permeability. To investigate the permeability of ground an apparatus of the form as represented in figure 2.6. can be used. The French engineer Henri Darcy was the first who did such experiments. He discovered that for one particular type of sand the rate of flow was always linearly related to the gradient in groundwater head. In the apparatus of fig. 2.6. the groundwater gradient equals the differences in head at both sides, divided by the length.

Darcy's law states: (see also fig. 2.6.)

$$v = -k \cdot i$$

where:

v = rate of flow (flow density) in m.s^{-1} ;

i = gradient in head in the direction of flow (dimensionless);

k = the permeability, a constant, in m.s^{-1} .

The minus sign in the formula indicates that the water flows in the direction of decreasing heads; the gradient is negative. Darcy investigated only the flow of

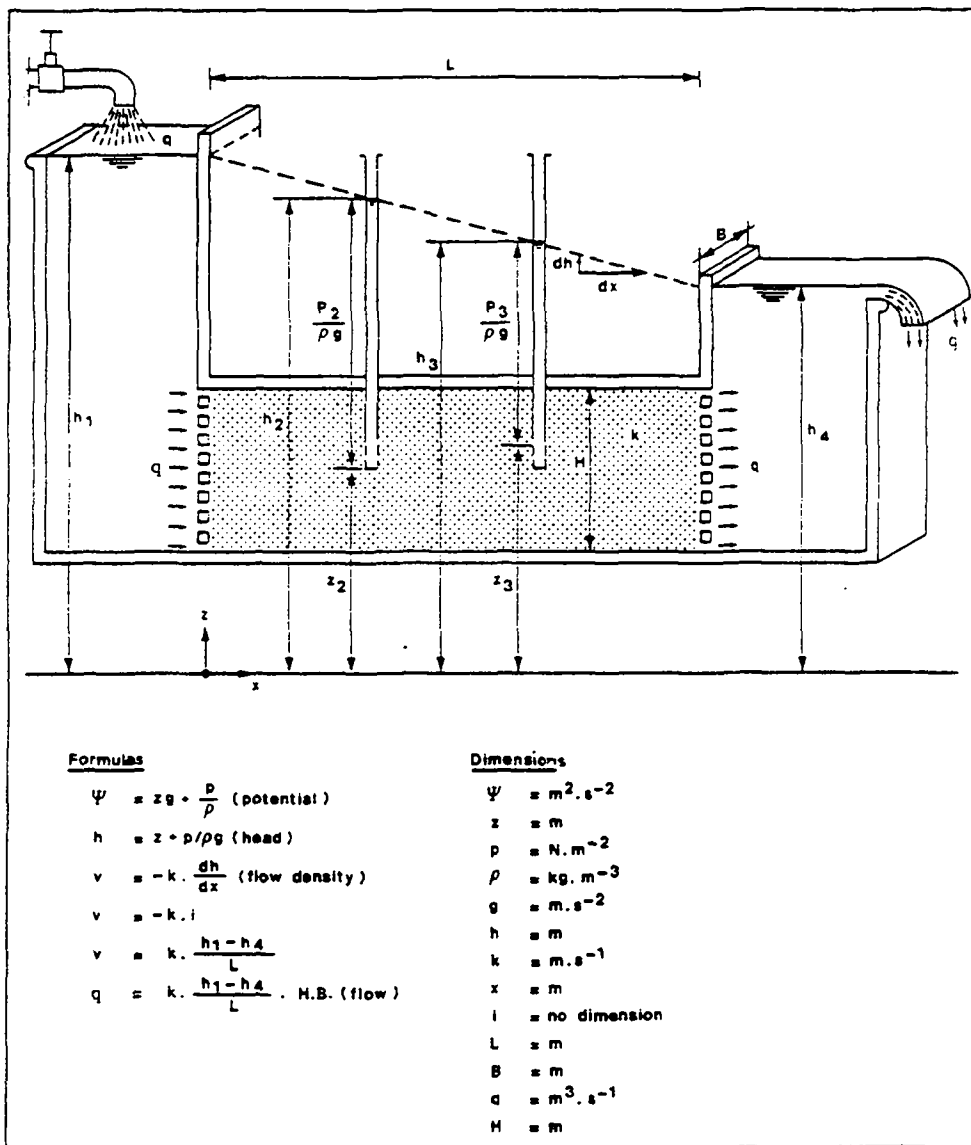

Fig. 2.6.

Illustration of Darcy's law.

water. According to his experiments the permeability proved to be a constant, only dependent on the properties of the ground concerned. Later investigators, using other fluids, discovered that permeability also depends on the properties of the fluid and notably on viscosity. Nevertheless, our subject is water and hence for our purpose we also may consider the permeability k to be a constant for one ground type. Permeability can be used to characterize the geohydrological properties of ground, be it sand of high permeability or clay of low permeability.

2.5.4. orders of magnitude of permeability

After Darcy many laboratory tests have been performed and field tests have been developed to investigate the permeability of various rocks to be found in the underground. It turned out that the unit m/day can be conveniently used. In that unity the following orders of magnitude roughly hold for the indicated soil materials.

Permeability of ground in m/day (orders of magnitude)

very compact clay	- 10^{-10} to 10^{-5}
unconsolidated clay	- 10^{-7} to 10^{-3}
sandy clay, clayey sand, stratified clays	- 10^{-3} to 1
fine sand with more or less silt	- 10^{-1} to 10
fine to medium sand with a low silt content	- 5 to 30
medium to coarse sand without silt	- 20 to 70
clean coarse sand	- 50 to 200
gravel, some types of limestone	- 100 to 5000, or even higher

As can be concluded from the wide ranges of values, it will for practical purposes always be necessary to determine permeability more precisely. It should additionally be remarked, that permeability strongly depends on a number of factors which are very difficult to simulate in a laboratory. Field tests to determine permeability should be strongly preferred.

2.5.5. actual velocity of groundwater flow

Darcy's law can be used to calculate the flow density if the hydraulic gradient and the permeability are known. This flow density, however, is not the actual velocity of groundwater flow. Flow density is the rate of flow per unit section

of the ground as a whole. However, for actual flow only the pores of the ground body are available, meaning that the flow velocity is larger than the flow density. Actual flow can be calculated if the porosity is known.

$$v_a \cdot p = v \cdot 1$$

(where 1 represents a unit section)

$$v_a = \frac{v}{F}$$

where:

v_a = actual flow velocity in m.s^{-1} ;

v = flow density in m.s^{-1} ;

F = porosity (dimensionless).

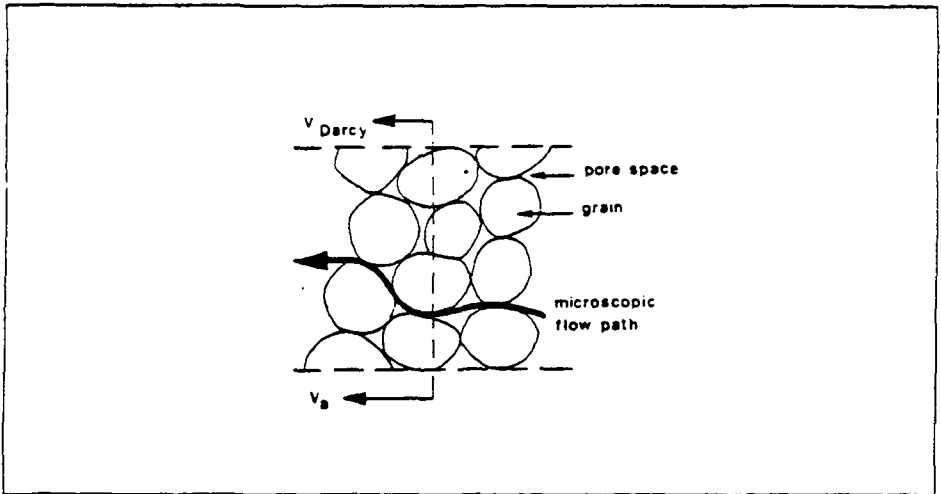

Fig. 2.7.

Flow density, actual velocity and flow paths on a microscopic scale

For sand the porosity is in the order of magnitude of 0.3 to 0.4. Therefore as a good rule of thumb, it may be taken that for sand the actual velocity is about three times the flow density. The actual velocity is an average value, representing the average rate of displacement of groundwater in the direction of flow. On a microscopic scale a wide range of velocities may be observed within the pore structure (fig. 2.7.).

2.5.6. transmissivity of aquifers

The flow density as calculated from Darcy's law is the flow per unit surface of a section perpendicular to flow (see fig. 2.6.). To compute the flow in an aquifer, the dimensions of the aquifer should be known:

$$Q = -k.i.H.B.$$

where:

Q = flow in an aquifer in $m^3.s^{-1}$ (in m^3/day , if k in m/day);

H = thickness of aquifer in m ;

B = the width of the section concerned in m .

Per unit width of an aquifer $L = 1 m$ and then:

$$Q = -k.H.i$$

The property kH is characteristic for an aquifer; it is called the transmissivity (symbol T). Tests have been developed to determine $T = kH$ in a direct way. From those tests permeability k can be derived by dividing by the thickness H .

2.5.7. hydraulic resistance of confining layers

Darcy's law can also be applied to vertical flow of water through less permeable confining layers (see fig. 2.8.). Per unit surface of such a layer holds:

$$v = - \frac{h_2 - h_1}{b} . k^* = \frac{h_1 - h_2}{b} . k^*$$

where:

v = flow density in the confining layer in $m.s^{-1}$ (m/day if k^* in m/day);

$h_1 - h_2$ = difference in head on both sides of the layer in m ;

b = thickness of the layer in m ;

k^* = permeability of the confining layer in $m.s^{-1}$ or m/day .

The value of $\frac{b}{k^*}$ is only dependent on the properties of the confining layer. It is called the hydraulic resistance c (in s , or in $days$) of the layer.

The formula for flow density through a confining layer becomes:

$$v = \frac{h_1 - h_2}{c} \quad (\text{m.s}^{-1} \text{ or m/day})$$

The above is in accordance with Darcy's law. If z and h are taken positive in the upward direction (see figure 2.8), the gradient i becomes negative as the heads h decrease in the upward direction.

The flow density has a positive value; the groundwater flows upward in the case of fig. 2.8.

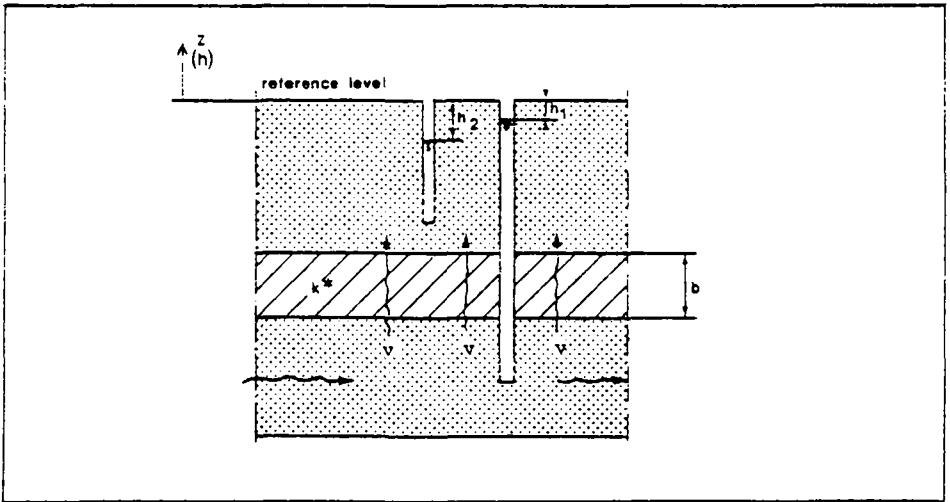
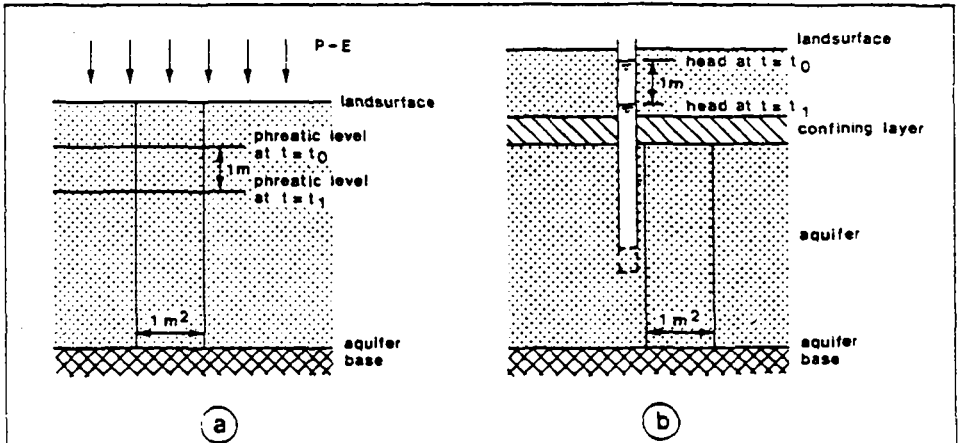

Fig. 2.8.

Vertical flow through a semi-confining layer

2.5.8. unsteady flow; storage; storage coefficient

Groundwater flow mostly has a non-permanent character, and thereby the differential equation becomes more complicated. Changes of heads and flow, however, are often seasonal fluctuations around a mean level. The groundwater heads and flow pertaining to that mean situation, we may consider to be in steady state.



(a)

Unconfined aquifer.

In unconfined aquifers the phreatic level may change, due to changes in (P-E) and groundwater flow. In between two positions of the water table a certain volume of water is stored, dependent on the storage coefficient (storativity). S (phreatic storativity or specific yield) is the volume of water released or stored in a column of the aquifer with a section of 1 m^2 at a lowering or rise of head respectively of 1 m.

S (dimensionless) is in the order of magnitude of 10^{-2} to 10^{-1} .

(b)

Confined or semi-confined aquifer.

In a confined aquifer no phreatic storage is possible; at any time the aquifer is fully filled with water. Yet, water can be stored at a change of head, due to:

1. Changes in water pressure, leading to expansion or contraction of the water.
2. Changes in grain pressure, leading to compaction or expansion of the grain structure. S (elastic storativity) represents the volume of water, released or stored in a column of the aquifer of 1 m^2 section and at a change of head of 1 m. For confined aquifers S is in the order of magnitude of 10^{-4} to 10^{-2}

Fig. 2.9.

Storage and the storage coefficient

In unsteady flow we have to deal with storage. By lowering the head, water is released from storage and reversely. Storativity is the quantity of water that is released or stored, per unit of drawdown per unit of surface of the layer concerned. In general this quantity depends on the type of aquifer (see fig. 2.9.).

- In confined or semi-confined aquifers, water pressures decrease due to a lowering of the head. Also the effective stress is increasing because of decreasing of the water pressure, while the total ground pressure remains constant. The ground matrix changes and hence the pore volume. Because of this elasticity - mechanism we speak of an elastic storativity.
- In unconfined aquifers the foregoing factors are negligible in comparison with the change in water volume due to lowering of the phreatic level. In this case storativity depends on the effective porosity (that is the pore space available for groundwater flow) and it is called the phreatic storativity (see fig. 2.9.).

3.

determination of groundwater flow patterns

3.1. introduction

The behaviour of groundwater, as a result of the forces acting on it can roughly be predicted with common sense in certain cases. But to determine the flow pattern in detail, a mathematical approach will give more accurate results. As soon as the groundwater head h is known as a function of place (coordinates x, y, z) and time t , the problem is solved. All other information of interest can be derived from the groundwater heads (e.g. the flow density and actual velocity).

Groundwater movement obeys in general two basic physical laws, which can be expressed in mathematical formulas. These laws are Darcy's law and the principle of continuity. Continuity means that no water can be lost or gained at any place. With these laws and knowledge of the properties of ground and water you may try to find the function $h(x, y, z, t)$. Mathematical combination of these laws and properties results in a so-called differential equation.

Groundwater flow occurs in a three-dimensional space. Hence we have to deal with flow components and ground properties in three different directions. If non-steady groundwater flow occurs (the situation varies with time), storage of water in the subsoil represents an extra complication.

Under steady conditions you should consider flow through an elementary ground volume (fig.3.1). The sum of in- and outflow is zero (continuity) and velocities are by Darcy's law a function of h . For the elementary volume one differential equation in h results.

By integrating, the function $h(x, y, z, t)$ for the whole considered groundwater body (for example a certain aquifer) has to be found. In general you need therefore the soil properties in every point as well as boundary and initial conditions to fix the flow field. Only in a few special cases the flow problem can be simplified in such a way that exact solutions of the differential equation can be found. These analytical solutions are continuous functions in time and space (h is known in every point of space and time). In most cases approximate solutions have to be formulated. Several methods are available (for example numerical methods). In other cases study of physical phenomena, analogous to flow of

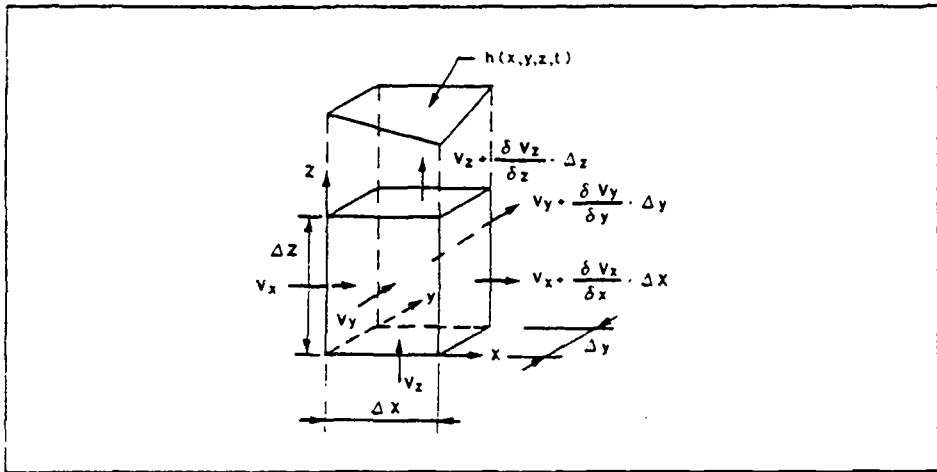

Fig. 3.1.

Groundwater flow through an elementary ground volume.

groundwater, can be used to solve a groundwater flow problem (electricity is much used). Hence, the following summary of solution methods results:

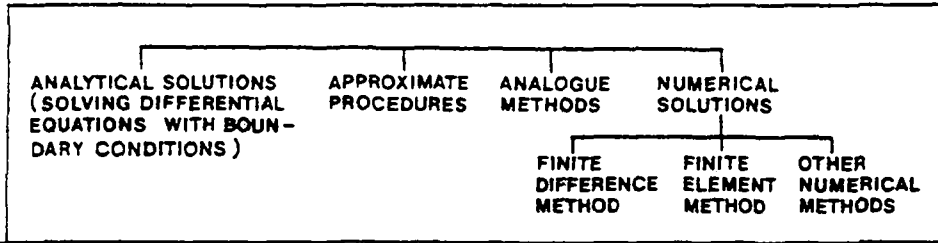

Fig. 3.2.

Solution of groundwater flow-problems

In fig. 3.3. the mathematical solution of groundwater flow problems is depicted schematically.

In section 3.2. we will discuss the types of groundwater flow.

In section 3.3. we deal with Darcy's law and the principle of continuity.

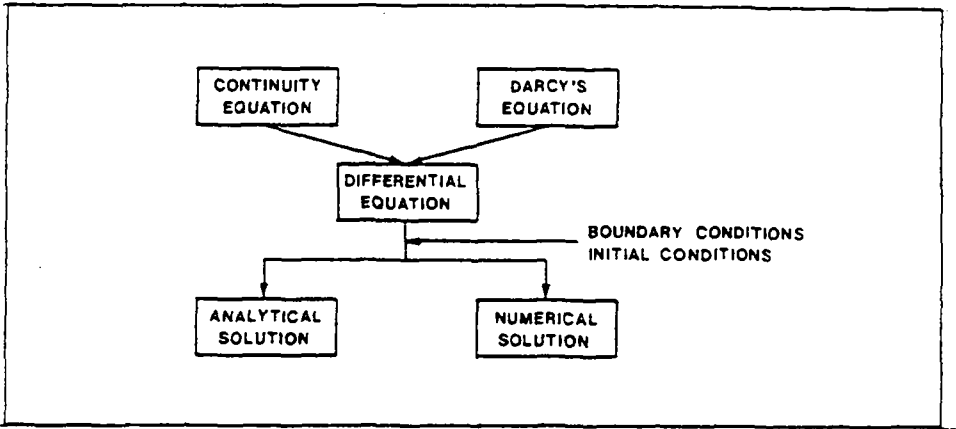

Fig. 3.3.

Schematic representation of mathematical solutions

In 3.4. the derivation is given of the differential equation for two-dimensional steady flow in a semi-confined aquifer. In 3.5. some cases are dealt with for which analytical solutions of the differential equation are available. In 3.6. we speak about approximate solutions, in 3.7. about analogue methods and in 3.8. some remarks are made about numerical methods. Section 3.9. deals with the principle of superposition and 3.10 gives some information about unsteady flow.

3.2. major subdivisions of groundwater flow

The subject of groundwater flow may be divided into several parts, according to the dimensional character of the flow, the time dependency of the flow and the properties of ground and water.

- Dimensional character

All groundwater flow in nature is to a certain extent three-dimensional. It is practically impossible to solve a natural three-dimensional groundwater flow problem unless symmetry features of the problem allow us to reduce the number of dimensions involved by one or two. Fortunately this can be done in the majority of all problems of groundwater flow.

- Properties of ground and water as to flow

A medium is called isotropic if its properties at any point are the same in all directions emanating from that point. It is called anisotropic if, on the other hand, some properties are affected by the choice of direction at a point. The

medium is of heterogeneous composition if its properties or conditions of isotropy or anisotropy vary from point to point in the medium; it is homogeneous if its properties, isotropic or anisotropic are constant over the medium. A medium therefore can be isotropic and heterogeneous at the same time, as for example when its permeability has no preference to orientation, yet varies in space.

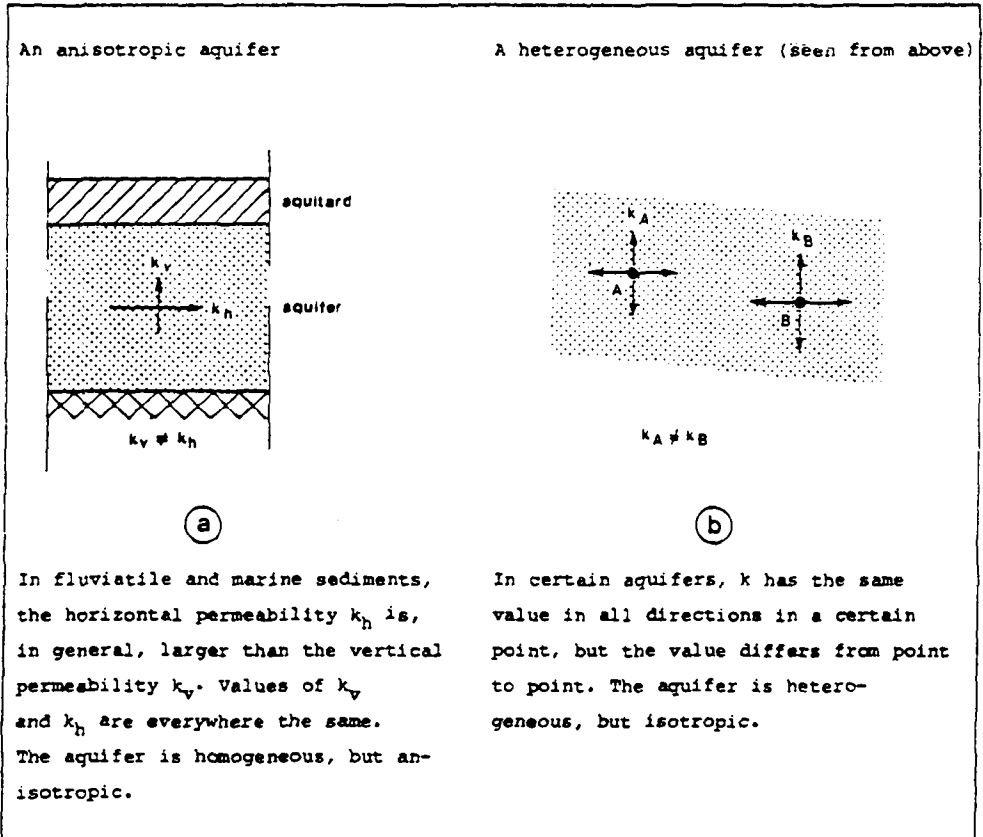

Fig. 3.4.

Anisotropic and heterogeneous aquifers

A fluid is homogeneous when it only concerns water. When also gasses or other fluids are involved it becomes heterogeneous. Our considerations are restricted to homogeneous flow, such that both the medium and the fluid are homogeneous.

- Time dependency

Groundwater flow may be evaluated quantitatively by the knowledge of the velocity, pressure, density, temperature, and viscosity of water. These characteristics of the water are commonly the unknown variables of the problem and may vary in place, from point to point in the formation, and in time (that is, assuming different values as time goes on). We assume here constant temperature and viscosity. If the unknown or dependent variables are functions of the space variables or independent variables x, y, z , only, the flow is steady. On the other hand, if the unknown are also functions of time, the flow is unsteady or time dependent. Steady flow may be conceived of as a limit case of unsteady flow, as time goes to infinity but also as the average of unsteady flow over a given period (see also section 3.10).

3.3. basic principles governing groundwater flow

3.3.1. Darcy's law in general form

Darcy's experiments gave the following result (see 2.5.3.):

$$v = -k \cdot i \quad (3.1.)$$

where:

v = rate of flow (flow density) in m.s.^{-1} ;

k = permeability, in m.s.^{-1} ;

$i = \frac{\Delta h}{\Delta s}$ = gradient, dimensionless;

h = head, in m;

s = covered distance, in m.

In words: the flow density in a certain direction is directly proportional to the negative head gradient in that direction (the flow occurs in the direction of decreasing head).

The appearance of the two difference symbols (Δ) in eq. (3.1.) shows that in the limit $\Delta s \rightarrow 0$,

$$v = -k \frac{dh}{ds} \quad (3.2.)$$

This is the differential formulation of (3.1.). Equation (3.2.) is also called Darcy's law.

For three-dimensional flow and isotropy (equal properties in all directions) holds:

$$v_x = -k \frac{\partial h}{\partial x} ;$$

$$v_y = -k \frac{\partial h}{\partial y} ;$$

$$v_z = -k \frac{\partial h}{\partial z} ;$$

where v_x , v_y and v_z are components of the flow density in x, y and z-direction and $\frac{\partial h}{\partial x}$, $\frac{\partial h}{\partial y}$ and $\frac{\partial h}{\partial z}$ are partial differentials of the groundwater head-plane in x, y-direction and z-direction. In layered soil anisotropy occurs; in that case we have to deal with different values of permeability in the three directions. In the foregoing, we assumed groundwater to have a constant density. However, that is not always realistic. Dissolved components in groundwater may cause, for example, differences in density. In such cases we have to take into account differences in water pressure instead of groundwater head gradients. In this chapter we deal with constant density of the groundwater. In chapter 4 we will further treat the most interesting problem in relation to differences in density, namely the relation between fresh and saline water.

3.3.2. the principle of continuity

To solve problems of groundwater flow, Darcy's law alone is not sufficient. In general it only gives three relations between four unknown variables: the three components of the flow density and the head. A fourth equation may be obtained by noting that the flow phenomenon has to satisfy the fundamental physical principle of conservation of mass. What kind of flow pattern occurs, no mass can be gained or lost. The consequence of this is, that always holds:

$$\text{inflow} = \text{outflow} + \text{changes in storage.}$$

For steady flow the changes in storage are zero; unsteady flow will be dealt with in a later chapter.

3.3.3. boundary conditions

In 3.1. it was pointed out that boundary conditions are needed to solve the differential equation. The boundary conditions of groundwater systems in nature

are of several types, perhaps the most common being those describing the conditions at a well. Since the porous media stops at the well face, the aquifer has a boundary at the well perimeter. The boundary conditions at wells are treated as a constant or a variable, but specified flux, or as a constant head, depending on whatever best describes the actual physical conditions.

Impermeable or nearly impermeable boundaries to aquifers are formed by underlying or overlying beds of rock, by contiguous rock masses (as along the wall of a buried rock valley), or by dikes, or similar structures. Permeable boundaries are formed by the bottom of rivers, canals, lakes and other bodies of surface water. These permeable boundaries may be treated as surfaces of equal head (specified), if the body of surface water is large in volume, so that its level is uniform and independent of changes in groundwater flow. The uniform head on a boundary of this type may, however, change with time due to seasonal variation in the surface water level. Other bodies of surface water, such as streams, may form boundaries with nonuniform distributions of head which may be either constant or variable with time. A small stream, for example, may be affected by a nearby withdrawal of groundwater if the withdrawal is at a rate of the same order of magnitude as the flow in the stream. Then the boundary condition can not be taken independent of the groundwater flow; that is, it would be a head-dependent flux.

3.4. the differential equation, governing steady groundwater flow in semiconfined aquifers

As an illustration of the above mentioned principles, we shall derive in this section the differential equation for steady flow in a semi-confined aquifer, schematically depicted in fig. 3.5.

The following assumptions are made:

- the aquifer has a constant thickness H ;
- in the aquifer, the vertical flow-component is negligible with regard to the horizontal one;
- soil and groundwater are homogeneous (no differences in properties from point to point) and isotropic (equal permeability in all directions);
- the groundwater has a constant density.

Generally, horizontal flow in the clay layers, bounding the aquifer, is negligible. Only vertical flow is taken into account. The second assumption means that

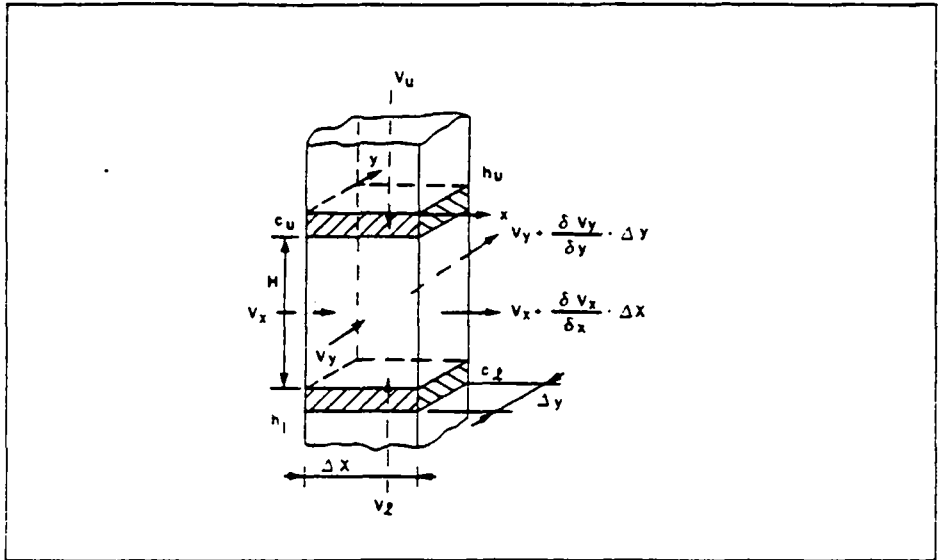

Fig. 3.5.

In- and outflowing quantities for an element in a semiconfined aquifer.

the flow in z-direction in the aquifer approximately equals zero. Hence, in accordance with Darcy's law, also the derivative of head equals zero ($\frac{\partial h}{\partial z} = 0$). So the head in z-direction has to be constant (hydrostatical pressure). Derivation of the continuity equation for a portion $\Delta x \cdot \Delta y \cdot H$ of the aquifer:

inflow, x-direction: $v_x \cdot H \cdot \Delta y$;

" y-direction: $v_y \cdot H \cdot \Delta x$;

outflow x-direction: $(v_x + \frac{\partial v_x}{\partial x} \cdot \Delta x) \cdot H \cdot \Delta y$;

" y-direction: $(v_y + \frac{\partial v_y}{\partial y} \cdot \Delta y) \cdot H \cdot \Delta x$;

In horizontal x- and y-directions the total inflow amounts to:

$$- \left(\frac{\partial v_x}{\partial x} + \frac{\partial v_y}{\partial y} \right) \cdot \Delta x \cdot \Delta y \cdot H$$

Combination with Darcy's law produces as total horizontal inflow:

$$q_h = k \left(\frac{\partial^2 h}{\partial x^2} + \frac{\partial^2 h}{\partial y^2} \right) \Delta x \cdot \Delta y \cdot B$$

From above and below, two flow volumes enter the considered element. Similar to the theory, dealt with in 2.5.7. these volumes can be written as follows:

$$q_u = - \frac{h-h_u}{c_u} \cdot \Delta x \cdot \Delta y \quad ; \quad q_l = - \frac{h-h_l}{c_l} \cdot \Delta x \cdot \Delta y$$

where:

h = groundwater head in the aquifer;

h_u, h_l = head in aquifers above and beneath the clay layers respectively;

c_u, c_l = hydraulic resistance of upper and lower clay layer respectively.

Equilibrium between total inflow and outflow yields the following differential equation:

$$kH \left(\frac{\partial^2 h}{\partial x^2} + \frac{\partial^2 h}{\partial y^2} \right) - \frac{h-h_u}{c_u} - \frac{h-h_l}{c_l} = 0 \quad (3.3.)$$

This equation holds for semi-confined aquifers; in the case of confined aquifers, the clay layers are impermeable and hence no water from above or beneath can enter the aquifers. The differential equation for this case is:

$$\frac{\partial^2 h}{\partial x^2} + \frac{\partial^2 h}{\partial y^2} = 0 \quad (3.4.)$$

This is called the Laplace-equation. The general equation, governing three-dimensional steady flow in confined isotropic aquifers is:

$$\frac{\partial^2 h}{\partial x^2} + \frac{\partial^2 h}{\partial y^2} + \frac{\partial^2 h}{\partial z^2} = 0 \quad (3.5.)$$

In special cases an exact solution can be found, using the right boundary conditions. In practice however, this is mostly complicated and hence we have to apply other solving techniques, for example numerical methods. The solution exists in this case of numerical values for certain chosen points (in time and space), which satisfy the differential equation and boundary conditions as best as possible.

3.5. analytical solutions of groundwater flow equations (steady flow)

3.5.1. introduction

In some cases the flow problem can be reduced, with good approximation, to a case for which an analytical solution exists or can be derived. In this section we deal with two important flow problems, the flow to a well within a circular island and flow through an infinite strip of land, bounded by open water. Another interesting flow problem is the radial flow to a well in different types of aquifers. The solutions of these flow problems are often used in pumping tests, carried out to determine the transmissivity kH of an aquifer. In chapter 5 we will discuss these pumping tests (the differential equations and their solutions).

3.5.2. radial flow in a completely confined aquifer

Radial flow often occurs in the field, for instance in the vicinity of a pumping well. For the solution of problems concerning radial flow the use of polar coordinates is particularly well suited (fig. 3.6.)

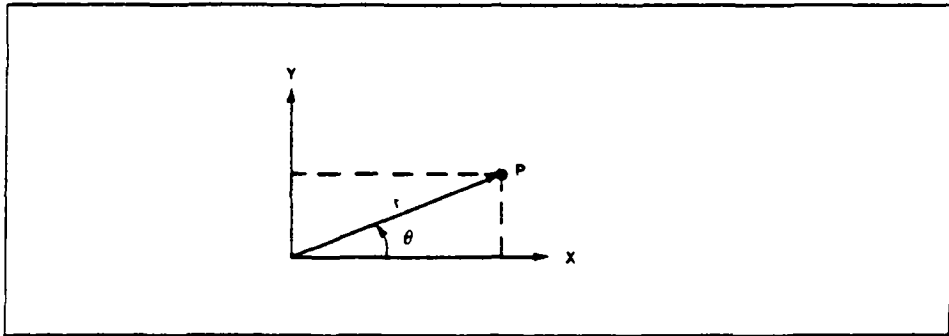

Fig. 3.6.

Cartesian coordinates and polar coordinates

A point P in cartesian coordinates is fixed by the distance x and y and in polar coordinates by the distance r and the angle θ . The basic equation (3.4.) in cartesian coordinates can be transformed into polar coordinates as follows:

$$\frac{\partial^2 h}{\partial x^2} + \frac{\partial^2 h}{\partial y^2} = \frac{d^2 h}{dr^2} + \frac{1}{r} \frac{dh}{dr} = 0 \quad (3.6.)$$

(The equation in polar coordinates is an ordinary differential equation, not a partial one, because in the case of radial flow the head will be independent of θ). A more compact form of (3.6.) is:

$$\frac{1}{r} \frac{d}{dr} \left(r \frac{dh}{dr} \right) = 0 \quad (3.7.)$$

Successive integration leads to the following general solution,

$$h = C_1 \ln r + C_2 \quad (3.8.)$$

Where C_1 and C_2 are constants, to be determined from the boundary conditions, differing for each particular case.

An example is the flow towards a well in a circular island, see fig. 3.7.

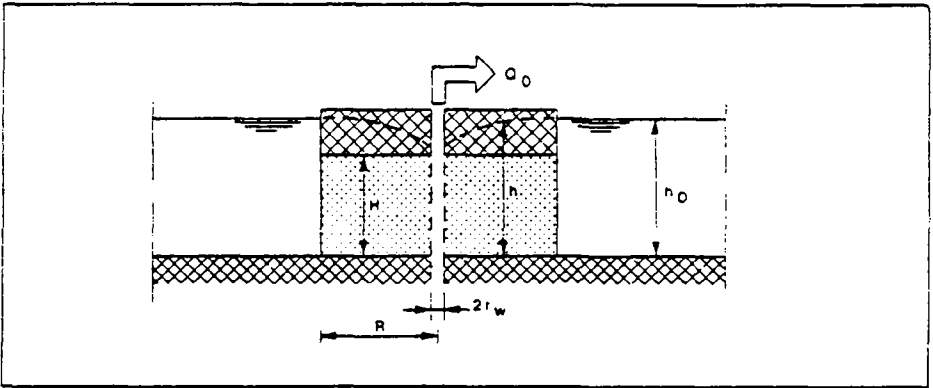

Fig. 3.7.

A well in a circular island, with confined flow

When the production of the well is Q_0 and the head at the outer circumference of the island is fixed, the boundary conditions are:

$$r = R: h = h_0$$

$$r = r_w: Q = -Q_0$$

The minus sign in the second boundary condition shows up since $-Q_0$ is the discharge entering the well, flowing in negative r -direction. With these boundary conditions the general solution (3.8.) can be transformed into the particular equation describing this problem:

$$h = h_0 + \frac{Q_0}{2\pi kE} \ln r/R \quad (r < R) \quad (3.9.)$$

The solution possesses certain interesting properties and possible applications, some being of fundamental importance.

- The solution is independent of the radius of the well r_w . This means that the influence of a well upon the head at a certain distance depends only on the discharge of the well, and not upon its radius.
- When R becomes infinitely large, the solution degenerates since then $\ln \frac{r}{R}$ tends to $-\infty$, whatever the value of r is. This means that the flow field in this case never becomes steady. If a steady state were possible in such an aquifer, the water flowing out of the soil through the well had to be supplied at infinity. As the formula indicates, this cannot be realised by lowering the head to a finite value. Fortunately, in most practical cases it is possible to define a certain finite outer radius of the aquifer.
- It is possible to calculate kH if we know the lowering of the head $\Delta h = h_0 - h$ at a given distance of the well. That is also possible when R is unknown, but yet drawdowns at two different distances r_1 and r_2 are known (measured in observation wells). The calculation of kH is done as follows:

$$\Delta h_1 = - \frac{Q}{2\pi kH} \ln r_1/R$$

$$\Delta h_2 = - \frac{Q}{2\pi kH} \ln r_2/R$$

$$\Delta h_1 - \Delta h_2 = \frac{Q}{2\pi kH} (\ln r_2/R - \ln r_1/R)$$

$$\Delta h_1 - \Delta h_2 = \frac{Q}{2\pi kH} \ln (r_2/r_1)$$

$$\text{Hence, } kH = \frac{Q \cdot \ln (r_2 / r_1)}{2\pi (\Delta h_1 - \Delta h_2)} \quad (3.10)$$

3.5.3. steady groundwater flow in unconfined aquifers

The upper boundary of an unconfined aquifer is the soil surface. Below soil surface an unsaturated zone exists, with partly filled pore space. Only below the phreatic surface (and in a limited zone above this level), all pores are filled with water. The first assumption that has to be made in the mathematical formulation of unconfined flow is, that flow of groundwater above the phreatic surface can be neglected. Flow occurs only in the saturated zone, below the groundwater

table. The phreatic table, however, is not a fixed plane, its position can vary in time. Some more assumptions have to be made (according to Dupuit), before the differential equation can be derived:

1. The flow is horizontal. Hence the head may be expressed by the height of the water table above the base of the aquifer.
2. The flow density is uniform over the depth of flow and may be expressed by $v = -k \frac{\partial h}{\partial x}$ instead of $v = -k \frac{\partial h}{\partial s}$, where x represents the horizontal distance and s denotes the actual flow path (fig. 3.8.).

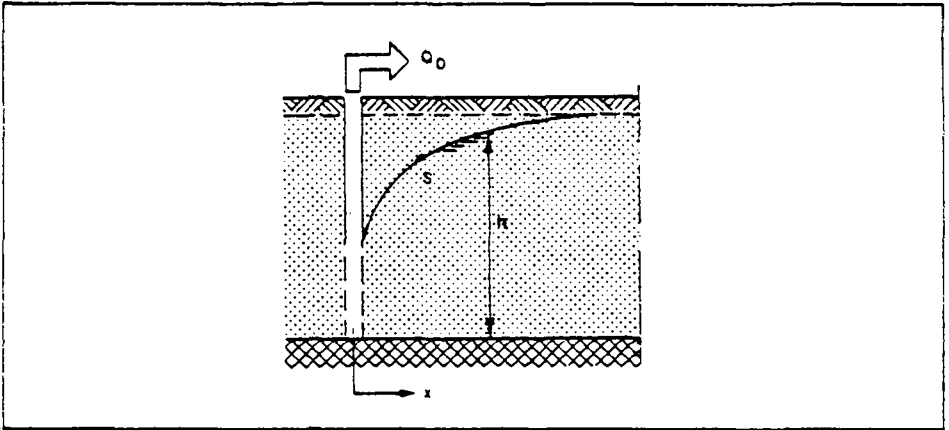

Fig. 3.8.
The Dupuit assumption: $\frac{\partial h}{\partial s} \approx \frac{\partial h}{\partial x}$

Dupuit's assumptions are reasonable for small slopes of the phreatic surface as mostly will occur in nature. Hence, in cartesian coordinates:

$$v_x = -k \frac{\partial h}{\partial x}$$

$$v_y = -k \frac{\partial h}{\partial y}$$

$$v_z = 0$$

In the derivation of the continuity equation we now have to take into account the derivatives of h in the x - and y -direction (see fig. 3.9.).

In fig. 3.9. the quantities of water are represented, flowing into and out of the considered element of the aquifer. Besides horizontal in- and outflow, rainfall

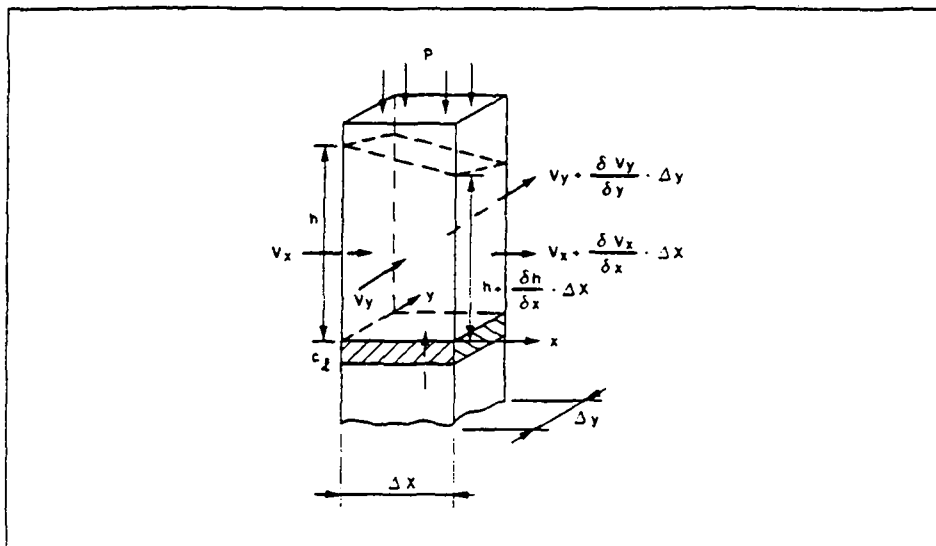

Fig. 3.9.

Groundwater flow through an element of an unconfined aquifer

from above enters the element (or evaporation loss occurs) and below in- or outflow can occur through a semi-permeable layer. Equalization of in- and outflow produces the continuity-equation. Substitution in Darcy's law gives the following general flow equation governing steady flow in an unconfined aquifer:

$$\frac{k}{2} \left\{ \frac{\partial^2 (h^2)}{\partial x^2} + \frac{\partial^2 (h^2)}{\partial y^2} \right\} + P - \frac{h-h_1}{c_1} = 0 \quad (3.11)$$

It has to be remarked, that in confined flow kh is constant and in unconfined flow it is not. The transmissivity should be kh , with varying h . Sometimes it is allowed, if the variations of h are very small with regard to h itself, to use a constant kh . In that case, the formulas for confined flow are approximately valid.

3.5.3.1. flow through an infinite dam with vertical faces

In civil engineering fig. 3.10. might represent a dam, with different water levels at both sides. In agriculture it might be a long parcel of land, bounded by ditches. More general, in groundwater flow this situation occurs when a long strip of land is bounded by areas of constant water level.

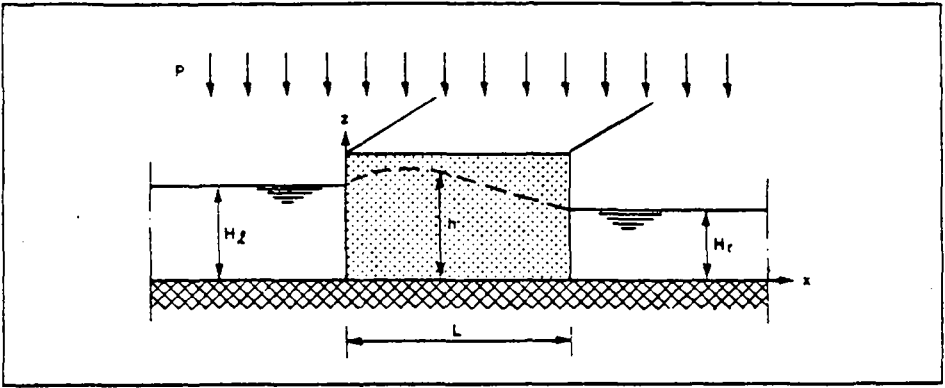

Fig. 3.10.

Flow through an infinite dam with vertical faces

Through the dam, groundwater flow occurs; rainfall infiltrates from above and flows to both sides. In this case, where \$h\$ is a function of \$x\$ only, (see fig. 3.10.) the basic differential equation becomes,

$$\frac{k}{2} \frac{d^2(h^2)}{dx^2} = -P \quad (3.12)$$

the general solution is:

$$h^2 = -\frac{P}{k} x^2 + C_1 x + C_2 \quad (3.13)$$

\$C_1\$ and \$C_2\$ can be calculated under the governing boundary conditions:

$$x = 0 : h = H_1$$

$$x = L : h = H_2$$

Substitution in (3.13) gives:

$$H_1^2 = H_2^2 - (H_1^2 - H_2^2) \frac{x}{L} + \frac{P}{k} x (L - x) = 0 \quad (3.14)$$

The discharge per unit width is a function of \$x\$:

$$Q = h \cdot v_x \text{ with } v_x = -k \frac{dh}{dx}$$

Elaboration gives:

$$Q_x = \frac{k}{2L} (H_1^2 - H_2^2) - P (4L - x) \quad (3.15)$$

About this flow problem some remarks can be made:

1. If rainfall equals zero, (3.14) becomes:

$$h^2 = H_1^2 - (H_1^2 - H_2^2) \frac{x}{L} \quad (3.16)$$

and
$$Q_x = Q = \frac{k}{2L} (H_1^2 - H_2^2) \quad (3.17)$$

This means that the groundwater table is of a parabolic form and that the quantity of water flowing through the dam is constant for every x (as it should be; no water is added).

2. With equal levels at both sides ($H_1 = H_2 = H$) and with rainfall we obtain:

$$h^2 = H^2 + \frac{P}{k} \cdot x (L - x) \quad (3.18)$$

$$Q_x = P (L/2 - x) \quad (3.19)$$

Substitution of $x = 1/2 L$ produces

$h^2 = H^2 + \frac{P}{k} \cdot 1/4 \cdot L^2$, which is the maximum height of the phreatic level in the middle of the dam. If $h \approx H$ (with large H and small L) then holds $(h+H) \approx 2H$ and:

$$\boxed{h-H \approx \frac{P}{2kH} \left(\frac{1}{4} L^2 \right)} \quad (3.20)$$

$(h-H)$ represents the maximum elevation in the middle.

3.5.3.2. radial flow to a well in a circular island (see fig. 3.11.)

With radial flow it is always recommendable to use polar coordinates. In this case the following differential equation holds:

$$\frac{1}{r} \frac{d}{dr} \left\{ r \frac{d(h^2)}{dr} \right\} = - \frac{2P}{k} \quad (3.21)$$

The general solution is:

$$h^2 = - \frac{P}{2k} r^2 + C_1 \ln r + C_2 \quad (3.22)$$

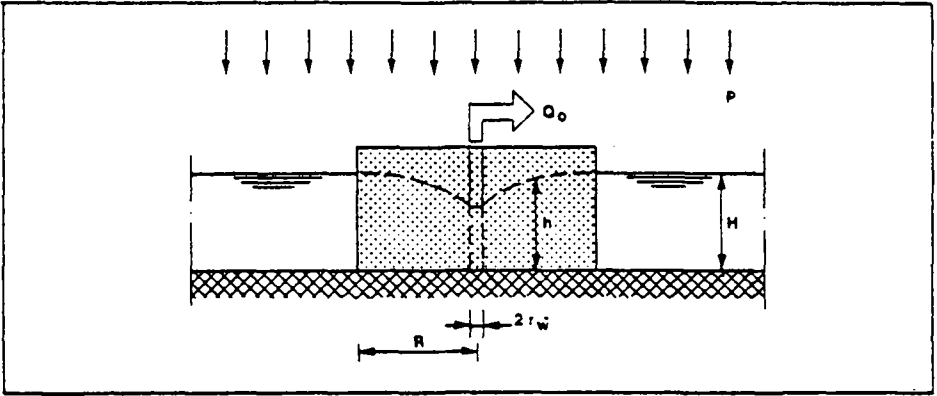

Fig. 3.11.

Radial flow in a well in a circular island

Boundary conditions are:

$$r = r_w : Q_r = -Q_o$$

$$r = R : h = H$$

Substitution of the boundary conditions yields:

$$h^2 = H^2 + \frac{P}{2k} (R^2 - r^2) - \frac{Q_o}{\pi k} \ln \frac{R}{r} \quad (3.23)$$

Neglecting rainfall, we obtain:

$$h^2 = H^2 - \frac{Q_o}{\pi k} \ln \frac{R}{r} \quad (3.24)$$

and, as a function of drawdown $\Delta h = H - h$:

$$\Delta h \left(1 - \frac{\Delta h}{2H}\right) = - \frac{Q_o}{2\pi k H} \ln \frac{r}{R} \quad (3.25)$$

If $\Delta h \ll H$, then we obtain the following formula:

$$\Delta h = - \frac{Q_o}{2\pi k H} \ln \frac{r}{R} \quad (3.26)$$

This is the same formula, as derived for confined flow.

3.6. approximate methods

Flow nets. Graphical solution of the differential equation

When the flow of groundwater is steady (time independent), the fundamental equation governing the groundwaterflow is:

$$\frac{\partial^2 h}{\partial x^2} + \frac{\partial^2 h}{\partial y^2} = 0$$

This equation is called Laplace's equation and must be solved in a given flow region, where certain conditions for h are specified along the boundaries of the region. Analytical solutions of the equation may only be found relatively easily, when the geometry of the flow region is relatively simple and when the conditions imposed along the boundaries of the region are also simple (see 3.4 and 3.5). Approximate graphical methods and a variety of model studies can replace analytical methods when the latter become too complex. A widely used graphical method consists of the fitting of a flow net to the boundary conditions. This method has marked advantages in speed of execution and range of applicability, especially when geometrically complicated boundaries occur.

The construction of a flow net to solve Laplace's equation graphically is relatively easy in problems with fixed boundaries and for confined flow, whereas it is slightly more complicated for unconfined flow, where the location of the water-table is not known beforehand. A flow net is a two-dimensional graph composed of two families of curves of a special nature: flowlines or streamlines which indicate direction of flow and equipotential lines connecting points of the same potential. Its use is therefore limited to the investigation of two-dimensional cross sections of a porous medium which are representative of the main flow and to the analysis of three-dimensional problems with either axial or radial symmetry. In fig. 3.12 we give an example of a flow net. Careful elaboration of the flow net will yield all necessary information on the problem concerned. Principally, a trial and error method has to be followed.

3.7. analogue methods

The basic laws for groundwater flow, notably Darcy's law and the principle of continuity, lead for homogeneous ground to Laplace's equation (see eq. 3.4). This

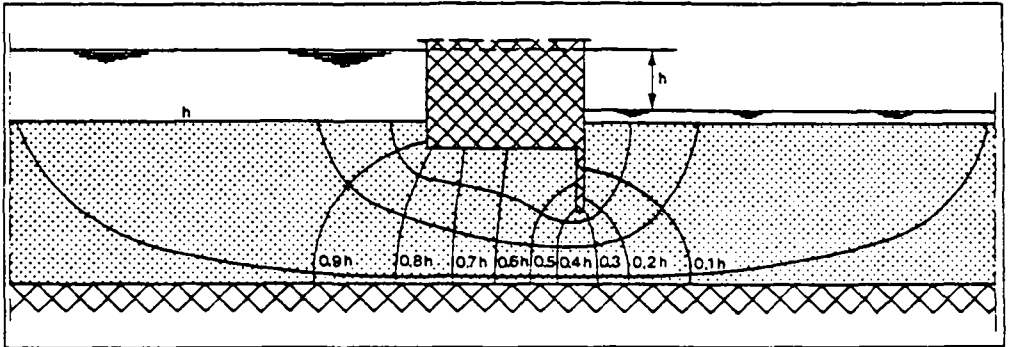

Fig. 3.12.

Construction of a flow net for groundwater flow underneath a dam. Potential lines and flow lines should form near squares. Then along the potential lines the drop in head is approximately constant. Flow lines are perpendicular to open boundaries and to potential lines.

differential equation also describes a number of other physical phenomena, such as e.g. heat flow, bending of membranes and electrical current. Comparison of problems solved in these fields may be of great help for the solution of similar groundwaterflow problems.

Another aspect of the various analogies is that some analogue phenomena can be easily studied in the laboratory; even so that laboratory investigations more easily yield the solution of the problem than a mathematical elaboration. Notably this is the case with electrical current, described by Ohm's law (which is similar to Darcy's law) and obeying the continuity principle. For the translation to groundwater problems only similar boundary conditions and the appropriate scale factors have to be applied. An example is given in fig. 3.13. The geohydrological problem, which is simulated, is flow underneath a small dam. The electrodes represent recharge boundaries. The other boundaries are impermeable.

3.8. numerical methods

At present, for the solution of more complicate flow problems (for example due to variations in the values of the ground characteristics within an area) almost in every case numerical methods are used, needing computers as a necessary tool. Particularly, two methods are used, the finite difference and the finite element method. In this course, only some comments are made on the first method.

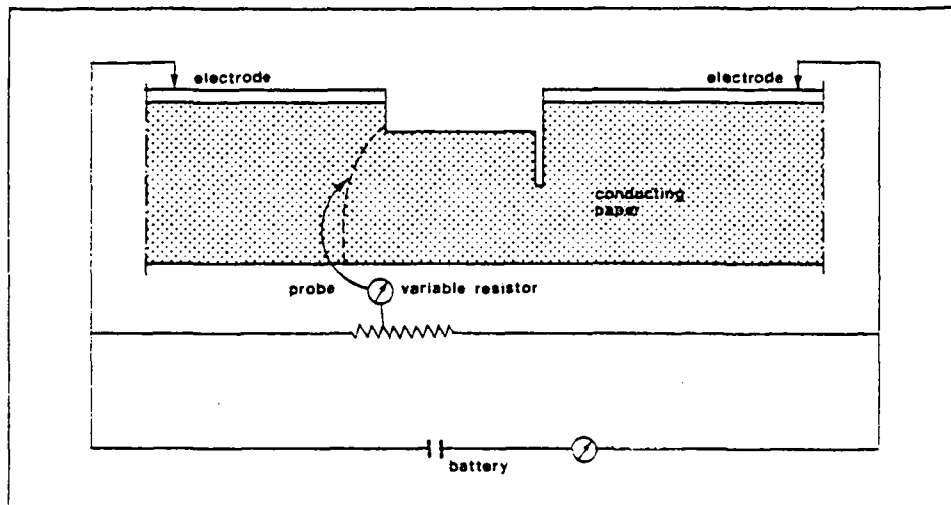

Fig. 3.13.

The same problem as Fig. 3.12. solved with an electrical analogon; at a fixed value of the resistor, zero indication of electrical current indicates an equipotential line.

The finite difference method

The area is divided into small elements. For every element a waterbalance is composed. The in- and outflowing quantities are dependent on the gradients in head and thus on the heads in the center of the elements. Initial values are given to these heads and iteratively the solution is determined, where every water balance is in equilibrium. Considering for example, the differential equation

$\frac{\partial^2 h}{\partial x^2} + \frac{\partial^2 h}{\partial y^2} = 0$, which holds for confined, homogeneous aquifers, it can be derived, that approximately holds:

$$\frac{\partial^2 h}{\partial x^2} = \frac{h_1 - 2h_o + h_3}{m^2} \quad \text{and}$$

$$\frac{\partial^2 h}{\partial y^2} = \frac{h_2 - 2h_o + h_4}{m^2} \quad (3.35)$$

where m is the mesh width of a square mesh of straight lines which is assumed to cover the field, see Fig. 3.14., and h is the head in the nodal points:

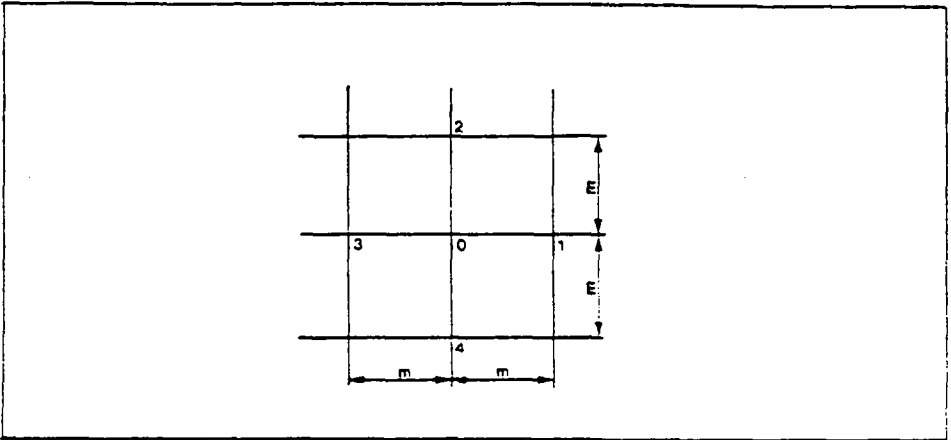

Fig. 3.14.

Elements of the finite difference method

The approximation for the differential equation becomes:

$$h_0 = 1/4 (h_1 + h_2 + h_3 + h_4) \quad (3.36)$$

This means that in every point of the mesh the local value of the head h has to be the average of the values in the four adjacent points.

The best way to carry out such a calculation, if a computer is not available, is:

1. Estimate values of h in every nodal point (good initial values are limiting the number of calculations which have to be made).
2. Select a nodal point and verify whether the equation holding for that point, is satisfied. If not, change the local value of h .
3. Select another point and repeat instruction 2, until sufficient accuracy is reached.

In more complicated cases, where the differential equation contains a number of other terms (e.g. flow through confining layers, withdrawals and the like) the same method can in principle be used. Then, however, the appropriate difference equations become somewhat more complicated.

For each particular problem they are to be derived.

3.9. the superposition principle

Most differential equations governing groundwater flow are linear (first degree equation). As a consequence, it is allowed to add effects of, for example, a number of withdrawals. The mathematical formulation is: the sum of two solutions of the differential equation is itself also a solution of that equation. When unsaturated flow is involved, the governing differential equations are not linear and the principle of superposition is not valid. In a number of other cases also the differential equations will not be linear and then the method of superposition may not be applied.

A first application of this principle is the calculation of the effect of an increasing withdrawal from a pumping well.

Assume that the drawdown in a certain point of an aquifer due to pumping with discharge Q , is:

$$\Delta h = C \cdot Q. \quad (3.37)$$

where C = a constant, representing the ground characteristics and holding for that special point.

If the discharge Q increases to, for example, $3Q$ than the drawdown becomes $3\Delta h$ at the point where first it was Δh (see fig. 3.15.).

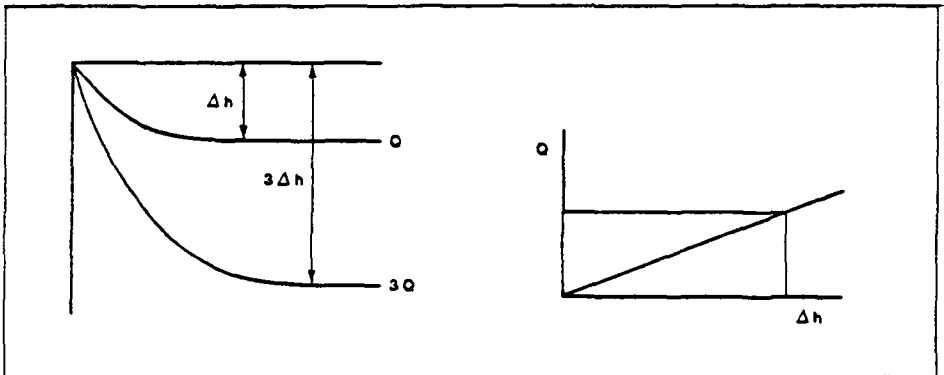

Fig. 3.15.

An illustration of the superposition principle

It also holds, that the drawdown in a certain point, due to pumping at several sites, with several discharges, can be obtained by adding the separate drawdowns of each well. Another application of the superposition principle is the case, that in a certain area different factors are influencing groundwater heads and -flow and we want to know the separate influence of one of them. We are now allowed to calculate the effect of that factor separately; all other influences together represent the so-called reference-situation.

3.10. unsteady flow

Unsteady flow calculations are more complicated than steady ones, because the governing differential equations contain derivatives to time. Sometimes we have to deal with unsteady flow, for example, in calculating flow patterns and draw-downs in the vicinity of wells, relatively short after start of pumping. For example, the differential equation for radial unsteady flow, caused by a pumping well in a confined aquifer has the following form:

$$kH \left(\frac{\partial^2 (\Delta h)}{\partial r^2} + \frac{1}{r} \frac{\partial (\Delta h)}{\partial r} \right) = S \frac{\partial (\Delta h)}{\partial t}$$

where kH = transmissivity in $m^2 \cdot s^{-1}$;

Δh = drawdown of the head in m;

r = distance to the central point in m;

S = storage coefficient (dimensionless);

t = time in s.

Compared to equation 3.6. this is again a partial differential equation because also time derivatives are present. Additional boundary conditions are that the drawdown at $t = 0$ equals 0 and that at $t = 0$ also the pump starts pumping at a rate $Q = Q_0$.

The solution of this problem, as given by C.V. Theis, is available in the form of tables and not in the form of a formula. These tables are represented in many handbooks on geohydrology. They are often used at the analysis of pumping tests. Also for other situations solutions are available. The subject of unsteady flow falls beyond the scope of this book.

4.

groundwater quality

4.1. the relation between quality and use

Groundwater quality may be expressed in terms of the physical, chemical and biological properties of water. Yet, we cannot give a general indication as to precisely which parameters are concerned and which values will mark the difference between good and bad quality. The reason is that the quality of water should be related to its use. Human consumption, livestock watering or irrigation supply for example will each pose different requirements to the properties of water. Water quite suitable for livestock may be totally unfit for human consumption.

We will take the quality of groundwater to be used for human consumption as a guideline. In this way we take into account that many geohydrological investigations aim at a determination of water resources available for public supply. Furthermore the number of parameters considered when the groundwater has to be drunk, will be so large that also most other types of use will be covered. We will restrict ourselves to physical and chemical properties. Determination of bacteriological parameters is complicated and is mostly not executed at the stage of the geohydrological investigation. Moreover, groundwater will be biologically unsafe only in exceptional situations. On the other hand, most physical and chemical properties of groundwater will be strongly related to normal geohydrological conditions. Both groundwater of very good quality with respect to human consumption and groundwater unfit to drink is normally present in the underground. Just to give you an idea the WHO recommendations for drinking water are represented in table 4.1.

To be clear, the values of table 4.1. hold for drinking water; groundwater containing certain elements in excess may be treated so that values below standards result. Treatment, however, will require expensive treatment plants. The costs of a treatment plant will increase dependent on the rate of difficulty of removal of the undesired constituents.

Very high costs will be involved at desalination of water, but a too high salt (chloride) content may be prohibitive to the use of groundwater for drinking. Therefore we make a major subdivision in fresh and brackish or saline groundwater.

Table 4.1.

WHO International Standards for drinking water

Substance or characteristic	Highest desirable level	Max. permissible level
colour	5 units on the Pt scale	50 units
odour	unobjectionable	unobjectionable
taste	unobjectionable	unobjectionable
suspended matter	5 turbidity units	25 units
total dissolved solids	500 mg/l	1500 mg/l
pH range	7.0 - 8.5	6.5 - 9.2
total hardness	1 mmol/l (Ca ²⁺ Mg ²⁺)	5 mmol/l (Ca ²⁺ Mg ²⁺)
ammonium (asNH ₄) [*]	0.5 mg/l	
calcium (as Ca)	75 mg/l	200 mg/l
chloride	200 mg/l	600 mg/l
copper	0.05 mg/l	1.5 mg/l
iron	0.1 mg/l	1.0 mg/l
magnesium (if more than 250 mg/l SO ₄ ²⁻ present)	30 mg/l	150 mg/l
magnesium (if less than 250 mg/l SO ₄ ²⁻ present)	150 mg/l	
manganese	0.05 mg/l	0.5 mg/l
nitrate [*]	45 mg/l	100 mg/l
nitrite [*]	0.1 mg/l	
sulphate	200 mg/l	400 mg/l
zinc	5.0 mg/l	15 mg/l

^{*} Derived from WHO European Standards.

We will start with an inventory of major and minor components of groundwater quality. Thereafter we will deal with quality variations to be found in fresh groundwater, which in general actively takes part in the hydrological cycle. Groundwater flowing at a significant rate generally will be fresh, as in 99 out of 100 cases its recharge will be fresh (precipitation, rivers). Therefore, the quality variations still to be remarked will be caused by factors related to geo-hydrological conditions.

The occurrence of brackish groundwater will for a large part - but not exclusively - be related to geological factors and notably marine influence. We will give a review of the factors involved in the origin of salt in the underground.

Finally, we will discuss how the geohydrologic behaviour of brackish groundwater differs from that of fresh groundwater and also what happens when both types are present.

4.2. quality components of groundwater

Groundwater contains in general a great quantity of different substances in solution. Some are relatively abundant, which means that their content is in the range of milligrammes per liter (mg/l) or sometimes even g/l; they are called major components of the groundwater quality.

Other compounds or elements are present in smaller amounts (they have to be counted in micrograms per liter ($\mu\text{g/l}$) or even less), they are called minor or trace constituents. In normal practice only major components are determined; for the determination of trace elements very sensitive and costly techniques are needed.

In chemistry the unit mole is much used to express the quantity of a chemical compound. In water-chemistry, concentrations can be represented in moles per liter or millimoles per liter (mmol/l). The formal definition of one mole is that it contains an equal amount of chemical entities as 0.012 kg carbon (C). The atomic mass of carbon is 12 and hence the definition means that the mass in kg of one mol of any chemical compound can be calculated if the atomic masses of the composing elements are known. In table 4.2. we will give data as to the major compounds in natural water.

Chemical compounds dissolved in water may have the form of molecules, but most are present in dissociated form as ions. For example, if ordinary kitchen salt dissolves in water, then no NaCl molecules will be present in the water, but the positive ions Na^+ and the negative ions Cl^- . Therefore the unit milli-equivalent per liter (meq/l) is also used (although no longer allowed in the new ISO recommendations). One milli-equivalent per liter equals one millimol/liter divided by the absolute value of the charge (valence) of the ion concerned. Hence 40 mg/l Ca^{2+} equals one mmol/l Ca^{2+} and 2 meq/l Ca^{2+} , the atomic mass of Ca being 40 and the charge of Ca^{2+} being 2.

The bulk of dissolved substances in natural (fresh and brackish) groundwater is formed by positively charged ions Ca^{2+} , Mg^{2+} , Na^+ , K^+ and sometimes NH_4^+ and the negative ions Cl^- , SO_4^{2-} , NO_3^- (in some cases also NO_2^-) and HCO_3^- . Positive and negative charges expressed in meq/l should balance each other, thus giving an indication on the reliability of the analysis. It is recommended that an analysis should at least permit to draw up this ion-balance. In table 4.2. the necessary data to compose the ion-balance are given.

Table 4.2.

The major ions contributing to the ion-balance of natural water

positively charged ions = cations	concentration in		negatively charged ions = anions	concentration in	
	mg/l or 1 mmol/l	p.p.m. 1 meq/l		mg/l or 1 mmol/l	p.p.m. 1 meq/l
calcium (Ca^{2+})	40	20	chloride (Cl^-)	35.5	35.5
magnesium (Mg^{2+})	24	12	sulphate (SO_4^{2-})	96	48
sodium (Na^+)	23	23	hydrogencarbonate (HCO_3^-)	61	61
potassium (K^+)	39	39	carbonate (CO_3^{2-})	60	30
ammonium (NH_4^+)	18	18	nitrate (NO_3^-)	62	62

Other parameters of importance for water supply purposes and consequently often included in normal analyses are the oxygen and carbon dioxide contents, the iron and manganese contents, hardness, aggressivity, pH, chemical oxygen demand, electrical conductance and temperature. Briefly the following remarks hold:

- Oxygen (O_2) and carbon dioxide (CO_2) form part of the atmosphere. Hence, they are also in dissolved form present in rainwater recharging the groundwater. The ratio between both gasses, however, will change in groundwater. Firstly the partial pressures (determining dissolution) in soil air will be different from atmospheric air, due to biological processes. Furthermore, both gasses are involved in a number of processes in the underground, leading generally to a decrease of the oxygen content and to an increase in the concentration of carbon dioxide.
- Iron and manganese can be present in groundwater as ions, but also in complex form with other (organic) compounds. The most common analyses yield the content as pure iron or pure manganese.

- Hardness is a property indicating the total amount of calcium- and magnesium ions in water. Hardness may be expressed in various units. We recommend to express it as mmol/l ($\text{Ca}^{2+} \text{Mg}^{2+}$) or meq/l ($\text{Ca}^{2+} \text{Mg}^{2+}$). Other units, such as German degrees or American degrees, can be readily derived if the appropriate conversion factors are applied.
- Aggressivity is the property that water can dissolve calcium carbonate, for example when it forms part of concrete constructions. Aggressivity is related to the carbondioxide content. When groundwater contains more carbondioxide than a certain equilibrium content, it will be aggressive.
- Acidity of water is expressed in pH units. Acidity is related to the content of hydrogen ions in water according to:

$$\text{pH} = -\log (\text{H}^+)$$

where (H^+) is the content in mol/l H^+ .

In practice, pH of groundwater can be measured with instruments.

- Chemical oxygen demand is expressed as the amount of oxidant to be used by the water concerned when a strong oxidant is added.
- Electrical conductance indicates the electrical conductivity of the water. It is expressed in milliSiemens/m (mS/m) or microSiemens/cm ($\mu\text{S}/\text{cm}$). As such it is related to total dissolved substances - the sum of the concentrations of all ions - in water.
- Temperature of groundwater is mainly related to the temperature at land surface and the so-called geothermal gradient. At a depth of more than 20 m, the average annual air temperature will be predominant. This means that groundwater generally will have a constant and relatively low temperature. As a rule of thumb, groundwater temperature approximately will obey the formula:

$$t = T + 0.03 d$$

where t = groundwater temperature in $^{\circ}\text{C}$ at depth $d(\text{m})$ and T is the average annual air temperature at land surface ($^{\circ}\text{C}$). At strong rates of groundwater flow deviations may occur. Groundwater can transport heat, especially when vertical flow prevails.

Naturally, a great number of other parameters may also be observed in groundwater, depending on each particular situation. Examples are the fluoride content, color, taste and smell. We will not discuss them.

When interpreting data on the quality of groundwater, one should always bear in mind that analyses may not fully represent the groundwater sampled. This may particularly be caused by changes occurring in the composition of water during sampling and transport. Sampling has to be done carefully to make sure that the water is indeed discharged from the right aquifer. A more serious attack on reliability is formed by the fact that gasses dissolved in groundwater are generally not in equilibrium with atmospheric conditions. This fact may notably result in an evasion of CO_2 from the sample and in an uptake of O_2 and these changes will have consequences for the values of some other parameters (e.g. iron and manganese, pH) as well. The analysis itself does not give an indication whether such changes have happened or not. Another possible source of error is when transport has taken too much time; especially under warm conditions, biologic life may develop in the sample, leading to changes in the chemical composition of the sample. Especially the nitrogen compounds are involved.

4.3. the composition of fresh groundwater

4.3.1. general

It is sometimes overlooked that the first factor involved in the composition of groundwater is the quality of water recharging the groundwater. In many cases this original composition will be strongly influenced by changes in quality occurring in the underground but mostly some of the original features can still be recognized.

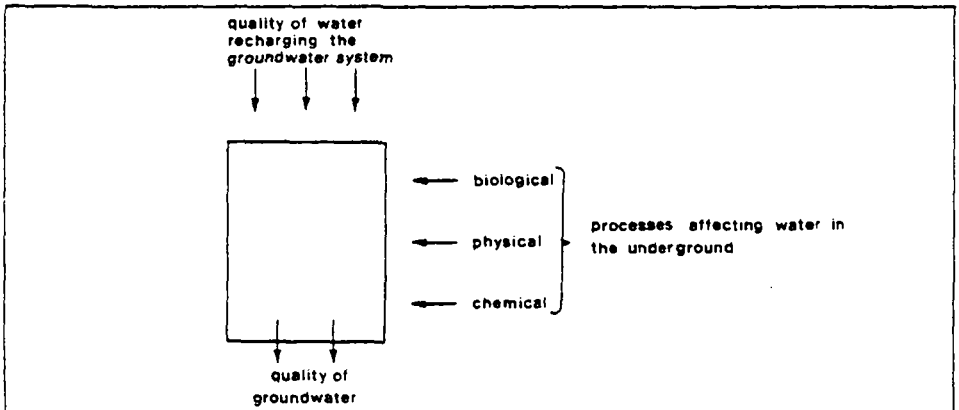

Fig. 4.1.

Composition of groundwater

4.3.2. recharge water

In general fresh groundwater may be recharged by rain, by irrigation water, or by rivers (or, in other words: surface water), by waste water or by a combination, each of them with their own characteristic composition.

Rainwater has a low content of dissolved substances, its composition depends on meteorological conditions and on the distance to the seashore. Near the coast higher contents occur. The values of some parameters measured in rainwater have increased locally and recently, due to increasing air pollution. When rainfall recharges the groundwater, part of the dissolved substances may be derived from aerosols deposited on trees, land surface etc. and thereafter leached by rain. Thereby contents in groundwater will increase.

Each river will, by nature, have its own composition of water, dependent on the drainage basin. Generally all contents of dissolved substances will be higher in river water than in rainwater. When the drainage basin is densely populated and industrialized, pollution may have a strong influence. Near the sea rivers may periodically contain saline water.

Irrigation water derived from rivers will have the same characteristics. Due to the seasonal intake of irrigation water, the seasonal fluctuations in river water quality should be considered. When percolating towards the underground, the irrigation water will contain residual fertilizers and other chemical compounds used in agriculture in the irrigated area.

Waste water may have a much varying composition depending on the quality of the water supplied and on the kind of waste (domestic or industrial). It should be noted that domestic waste water traditionally contains more Na^+ and Cl^- than the original water. Nitrogen compounds will also occur in most domestic waste.

4.3.3. changes occurring during and after recharge

Most groundwater will get its main quality characteristics during recharge. The relevant processes are condensation by evapotranspiration, production of carbon dioxide by biological processes mainly in the upper soil zone and dissolution of

soluble ground partides. Also adsorption of substances dissolved in groundwater to ground particles may take place. Groundwater may further be liable to redox reactions.

a. Evapotranspiration

A very important physical process to influence groundwater quality is evapotranspiration or, to be more precise, the combination of evaporation and plant transpiration (evapotranspiration) which may occur during recharge of groundwater. Evaporation may be conceived as a distillation process resulting in an evasion of H_2O and a condensation of the remaining solution. Hence, theoretically all concentrations of dissolved substances have to be multiplied by a certain condensation factor. This factor follows from the ratio between the total amount of water supplied and the remaining amount of water after evaporation took place (e.g. this factor is equal to the ratio $(P-R)/I$; rainfall minus surface run-off divided by groundwater recharge). Under conditions where actual evapotranspiration nearly equals rainfall, the recharge may take very small values. Consequently, the condensation ratio will be very high. Ratio's in the order of magnitude of 10 to 100 and even more can occur. Even perfectly fresh recharge water may turn brackish by such high condensation ratio's. For irrigation water with more dissolved substances this danger becomes even greater. Numerous examples can be cited where groundwater became saline due to wrong irrigation practices.

One remedy is to install a drainage system by which excess salt can be carried away.

b. Biological processes

(Micro)biological processes may take place under aerobic or anaerobic conditions.

Aeroby

Plants assimilate CO_2 and H_2O using energy derived from sun radiation:

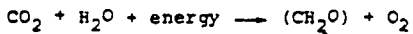

The energy contained in the organic compound (CH_2O) is essential for the plant's life. It is freed by a second process which may reyield CO_2 and where O_2 is used. This last process is preponderant in soil, radiation being negligible there. It will cause an increase of gaseous CO_2 in soil air, if compared with the atmosphere. Similarly, as long as groundwater contains dis-

solved O_2 , organic matter in the soil or in the water may be mineralized by micro-organisms using O_2 and yielding CO_2 and H_2O as main products. Generally the O_2 content will decrease and the CO_2 content will increase in the direction of the groundwater flow. Under aerobic conditions also, a mostly limited amount of SO_4^{2-} and a sometimes considerable quantity of NO_3^- or NO_2^- may be formed by biological activities in the soil.

Anaeroby

When oxygen is absent, organic matter may be broken up simultaneously with a reduction of nitrate, sulphate or carbon dioxide contents.

One of the end products of anaerobic processes - also other fermentation processes may occur in the underground - is generally an increased content of carbon dioxide. Other more specific end products, mostly in gaseous form are nitrogen (N_2), hydrogensulphide (H_2S) and methane (CH_4).

c. Dissolution and sorption processes

When soluble material is present in aquifers, it may be dissolved by groundwater. However, this possibility should not be overestimated. Fluvial sediments, forming aquifers flushed by fresh groundwater, will not contain much soluble matter anymore. An exception should be made for salts brought in by man (for example kitchen salt or fertilizers). Another exception concerns the case where aquifers are composed of volcanic sediments. An outstanding feature of volcanic products is that they have generally not been transported by normal surface water (such as rain, rivers or the sea). For this reason they still may contain components which are readily soluble in normal groundwater and thereby changing its quality. An example is the occurrence of pyrite (FeS_2) in these volcanic products. Iron sulphides are reduced species and when they come into contact with water having oxidizing properties, they will dissolve. The solution products are ferrous iron and sulphate (SO_4^{2-}). The resulting water will be aggressive and show a strong tendency to dissolve calcium carbonate.

Groundwater containing CO_2 will be able to dissolve calcium carbonate whenever it is present in sediments, whereas groundwater without CO_2 will do so only in relatively very small amounts. Normal groundwater will always contain CO_2 mainly as a result of (micro)biological processes.

The following equilibrium holds:

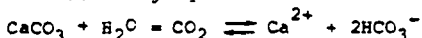

The fact that equilibrium exists, implies that not all CO_2 is used. If groundwater (in the absence of CaCO_3) contains more than the equilibrium concentration of CO_2 , it is called aggressive towards calcium carbonate, therefore it has a tendency to dissolve CaCO_3 when the occasion occurs. Calcium carbonate will precipitate if for some reason CO_2 is emitted from the groundwater (e.g. under changing pressure conditions). Under normal conditions the pH of groundwater will largely depend on the relation between the values of the CO_2 , HCO_3^- (and CO_3^{2-}) concentrations. At normal pH's CO_3^{2-} will be absent.

Sorption processes are the general name for processes describing the physico-chemical interaction between groundwater components and the aquifer material. They can be distinguished in adsorption (dissolved substances in groundwater adhere to aquifer minerals), in leaching (aquifer components dissolve in groundwater) and in ion exchange (mutual exchange between aquifer material and groundwater components). Sorption processes play a role with the composition of natural groundwater, but they are even more important with regard to the behaviour of pollutants in groundwater.

An example of ion-exchange in natural groundwater is the cation exchange, often to be observed in groundwater of coastal areas. Fresh groundwater flowing through marine sediments may be liable to increased Na^+ ions in exchange of Ca^{2+} ions adsorbed by ground material. The reverse may also occur, namely when brackish groundwater flows through fresh sediments.

Pollutants (for example heavy metals or biocides), will in many cases - but not always, and not at any rate - adsorb at ground material as these substances in groundwater are mostly not in equilibrium with ground minerals. The adsorption capacity may be thus large that for many years a pollution may not reach greater depths than a few centimetres.

d. Reduction - oxidation (redox) processes

A well-known example of a redox process concerns the behaviour of dissolved iron in groundwater.

Iron compounds may be found underground both in solution as a component of the groundwater and in solid form as part of the aquifer. The relation between dissolved and precipitated forms can for a large part and at least

qualitatively be explained by theories on reduction - oxidation (redox) conditions in aqueous solutions. Redox conditions for a certain solution are expressed by the value of the redox potential Eh (in Volt) of that solution, which can be measured (in practical cases not without difficulties). Now if Eh and pH of a certain solution, being at equilibrium, are known as well as all compounds involved (both in dissolved and in solid form), theoretically all concentrations of different ions in solution can be computed. Generally, oxidized forms of involved elements are present at high and reduced forms at low redox potentials. For a number of common compounds of iron such an Eh-pH diagram, also called a stability field diagram, is given by Hem (1970).

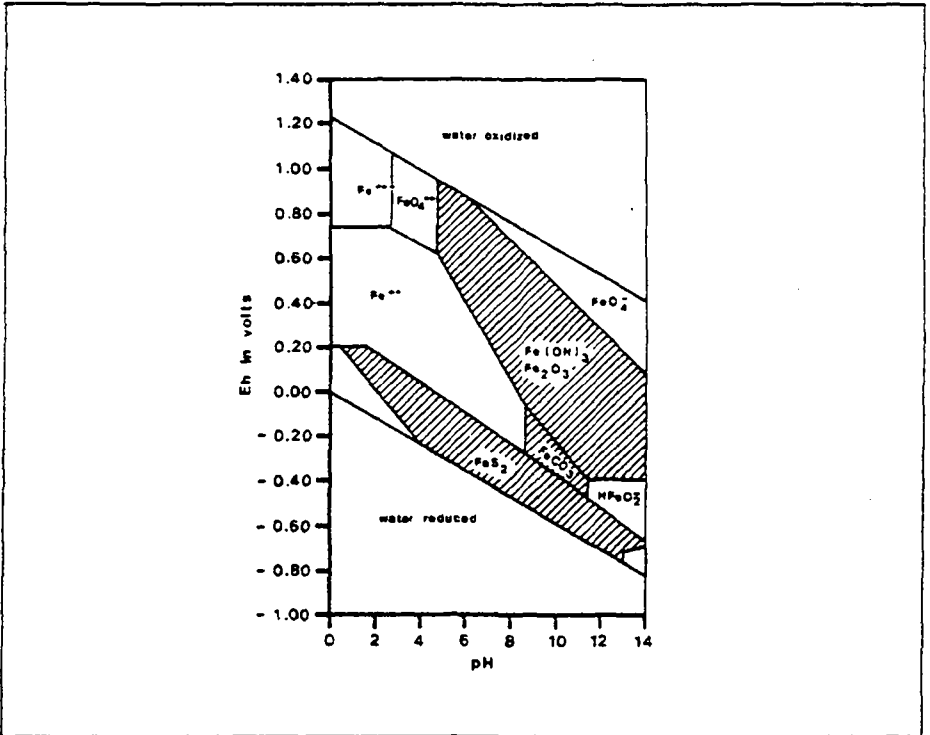



Fig. 4.2.

Eh-pH diagram after Hem for solid forms of iron  and dissolved forms of iron 

Activity of sulfur species 96 mg/l as SO_4^{2-}

Activity of carbon dioxide species 61 mg/l as HCO_3^-

4.3.4. a hypothetical example of fresh groundwater composition

To illustrate the foregoing, we have composed a hypothetical example how the groundwater quality can result from a number of factors. Although this example is imaginary, we will try and present realistic figures. We choose rainfall as a starting point. In following the hydrological cycle, the next steps can be imagined:

a. Assumedly the rainfall concerned has the following characteristics:

(Cl ⁻)	= 3 mg/l Cl ⁻	(Ca ²⁺)	= 2 mg/l Ca ²⁺
(SO ₄ ²⁻)	= 4 mg/l SO ₄ ²⁻	(Mg ²⁺)	= 1 mg/l Mg ²⁺
(NO ₃ ⁻)	= 1 mg/l NO ₃ ⁻	(Na ⁺)	= 2 mg/l Na ⁺
(HCO ₃ ⁻)	= 3 mg/l HCO ₃ ⁻	(Fe)	= 0
(CO ₂)	= 10 mg/l CO ₂	(Mn)	= 0
pH	= 5.6	E.C.	= 25 μS/cm

b. In the unsaturated zone just below land surface $1/2$ mmol/l CO₂ = 22 mg/l CO₂ will be freed by biological processes. Of the now total amount of 32 mg/l CO₂, 15 mg/l CO₂ is directly involved in the reaction:

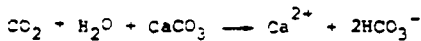

leading to extra $15/44 \times 40 = 14$ mg/l Ca²⁺ and $30/44 \times 61 = 42$ mg/l HCO₃⁻ in the solution.

c. The relation between rainfall and recharge will lead to a condensation factor of 3, implying that, in neglecting surface runoff, the evapotranspiration amounts to 2/3 of the rainfall. The resulting quality of soil moisture will become from b and c:

(Cl ⁻)	= 9 mg/l Cl ⁻	(Ca ²⁺)	= 48 mg/l Ca ²⁺
(SO ₄ ²⁻)	= 12 mg/l SO ₄ ²⁻	(Mg ²⁺)	= 3 mg/l Mg ²⁺
(NO ₃ ⁻)	= 3 mg/l NO ₃ ⁻	(Na ⁺)	= 6 mg/l Na ⁺
(HCO ₃ ⁻)	= 135 mg/l HCO ₃ ⁻	(Fe)	= 0.1 mg/l Fe
(CO ₂)	= 51 mg/l CO ₂	(Mn)	= 0
pH	= 6.7	E.C.	= 250 μS/cm

d. By a source of pollution the following concentrations are added:

(Cl ⁻)	= 36 mg/l Cl ⁻	(Ca ²⁺)	= 15 mg/l Ca ²⁺
(SO ₄ ²⁻)	= 24 mg/l SO ₄ ²⁻	(Na ⁺)	= 25 mg/l Na ⁺
(NO ₃ ⁻)	= 20 mg/l NO ₃ ⁻		

e. In flowing through the saturated zone the above aggressive water will encounter sufficient CaCO_3 and thereby Ca^{2+} and HCO_3^- ions will go into solution so that the amount of free CO_2 will reduce to 12 mg/l CO_2 . The groundwater in the saturated zone thereafter will obtain the following composition.

(Cl^-)	= 45 mg/l Cl^-	(Ca^{2+})	= 98 mg/l Ca^{2+}
(SO_4^{2-})	= 36 mg/l SO_4^{2-}	(Mg^{2+})	= 3 mg/l Mg^{2+}
(NO_3^-)	= 23 mg/l NO_3^-	(Na^+)	= 31 mg/l Na^+
(HCO_3^-)	= 243 mg/l HCO_3^-	(Fe)	= 0.3 mg/l Fe
(CO_2)	= 12 mg/l CO_2	(Mn)	= 0.03 mg/l Mn
pH	= 7.5	E.C.	= 600 $\mu\text{S/cm}$

f. Next, the groundwater may flow through a layer with much organic material and where anaerobic conditions prevail. All nitrate will be reduced and half of the sulphate content. The resulting free CO_2 will directly be involved in the dissolution of CaCO_3 , but also in the dissolution of magnesium compounds, so that again a carbondioxide concentration of 12 mg/l CO_2 results.

The composition of the groundwater will then be changed into:

(Cl^-)	= 45 mg/l Cl^-	(Ca^{2+})	= 90 mg/l Ca^{2+}
(SO_4^{2-})	= 18 mg/l SO_4^{2-}	(Mg^{2+})	= 10 mg/l Mg^{2+}
(NO_3^-)	= 0	(Na^+)	= 31 mg/l Na^+
(HCO_3^-)	= 294 mg/l HCO_3^-	(Fe)	= 5 mg/l Fe
(CO_2)	= 12 mg/l CO_2	(Mn)	= 0.5 mg/l Mn
pH	= 7.6	E.C.	= 650 $\mu\text{S/cm}$

Note: due to anaerobic conditions also significant amounts of iron and manganese will go into solution (because of a lowering of the redox potential).

The ion-balance of the last formed groundwater will have the following form:

Anions

45/35.5 mmol/l Cl^-	= 1.27 meq/l
18/96 mmol/l SO_4^{2-}	= 0.38 meq/l
294/61 mmol HCO_3^-	= 4.82 meq/l

total = 6.47 meq/l

Cations

90/40 mmol Ca ²⁺	= 4.50 meq/l
10/24 mmol Mg ²⁺	= 0.83 meq/l
31/23 mmol Na ⁺	= 1.35 meq/l

total = 6.68 meq/l

Note 1: The ion-balance is not fully in equilibrium as it should be. This situation, however, reflects practice where analyses never will show a perfect fit.

Note 2: The hardness is 2.67 mmol/l Ca²⁺, Mg²⁺.

Note 3: Again we remark that the example is imaginary; in reality the impact of the processes may be different and furthermore other processes may be involved.

4.4. sources of brackish or saline groundwater

4.4.1. general.

Definitions: Brackish water has a salinity (= total dissolved salts) smaller than that of seawater, yet large enough that it cannot be used for drinking. The salinity of saline water equals or is larger than the salinity of seawater. A brine contains water of a very high salinity.

In practice, if indicating salinity with the chloride concentration, you may take the following limits:

- fresh water contains less than 600 mg/l Cl⁻;
- brackish water has a chloride content in between 600 mg/l Cl⁻ and 19000 mg/l Cl⁻;
- saline water contains 19000 mg/l Cl⁻ or more.

In natural groundwater, mostly the water will be either fresh or brackish. Yet, in exceptional cases, you may encounter saline groundwater or even brines in the underground. According to the above definitions, brackish groundwater might be conceived as a mixture between fresh water and seawater. Indeed, in many cases marine influence can be discerned in the origin of brackish groundwater. Nevertheless, also other factors may be involved and furthermore the marine influence may take different forms. In discussing the origin of brackish or saline groundwater, we will distinguish between the original sources of salt brought in the

underground and in processes by which a displacement of salt or changes in content are brought away.

4.4.2. *various origins of brackish groundwater*

Two original sources of salt in the underground exist. Firstly, salt may form part of the ground and be dissolved by groundwater. Secondly, salt can be brought to the ground by water containing dissolved salts.

a. Ground containing salt

Most igneous rocks will not contain much soluble salt. Many sediments, however, are of marine origin and at their time of deposition they contained salt. Part of the salt may still be present at later geological periods. Extreme examples of salt containing sediments are layers of pure salt or salt domes in the underground. Quite commonly, however, marine clay - or sand layers still have certain salt contents. The salt may be freed either by flushing with water or, in the case of clay layers, by compaction due to compression. Especially in the case of compaction of marine clay layers the water driven out may have very high salt contents (brines).

b. Salts brought in by water

The most obvious example of water containing salt is seawater. Seawater may flow to the underground in coastal areas where it will build up a salt water wedge underneath fresh groundwater. This process is called seawater intrusion. Its influence will be restricted to small zones along the coast. Furthermore during periods of transgression (see chapter 2), seawater may cover fresh sediments. Salt may intrude in the underground either by convective flow or by the phenomenon of molecular diffusion.

Nevertheless, also the very small amounts of salt brought in by rainfall may cause brackish groundwater bodies. The original fresh water may be liable to consecutive steps of heavy condensation by evapotranspiration and become brackish. An intermediate stage may for example be that rivers draining already condensed groundwater are used for irrigation in dry climates. Evaporation may be brine-forming if the water concerned consists of seawater.

4.4.3. *physical phenomena influencing salt contents*

Three major physical processes influence the salt content of brackish groundwater, namely condensation by evaporation, molecular diffusion and hydrodynamic dispersion.

a. Condensation by evapotranspiration

We already described the effect of evaporation on groundwater quality in the previous chapters. Two examples may illustrate the role of evaporation in the forming of brackish groundwater bodies.

1. Situations occur where inland valleys are surrounded by hills without having a river outlet. These valleys receive groundwater from the hills around, but evapotranspiration is so high that no groundwater is discharged to rivers. This means that the salts brought in by the groundwater flow will remain in the underground, whereas fresh water evaporates. If this situation continues for years and years, the groundwater in such valleys may turn brackish or even saline. The valley becomes a salt desert.
2. A relatively fresh river flows through a desert. The inhabitants divert part of the river water to irrigate the desert without, however, installing a drainage system. Practically all the irrigation water will be used by evapotranspiration. Again the salts will remain in the soil. After a number of years the irrigated fields will become useless because of salination.

b. Molecular diffusion

Even when no flow of groundwater occurs, yet the dissolved ions may be moving due to molecular diffusion. The acting forces are differences in concentrations. Molecular diffusion is a very slow process; the effect will only become significant after very long periods (see figure 4.3.). In flowing groundwater this effect may be neglected, but in stagnant groundwater it may play a significant role. An example is the situation where fresh sediments are covered by sea during a long lasting transgression. Then the fresh sediments may become salinated by diffusion.

c. Hydrodynamic dispersion

When groundwater containing variable concentrations of salt is flowing through a porous ground, the distribution of salt will change in the direction of flow. A certain spreading occurs both in the direction of flow and perpendicular to it; this mixing tends to decrease the gradients in concentration. The phenomenon is called hydrodynamic dispersion and it is caused by the non-rectilinear pathways of flow on microscopic scale. If fresh groundwater flows over a layer containing brackish or saline water at rest, lateral hydrodynamic dispersion will bring upward salt ions. For this reason the originally fresh flow will salt up in the direction of flow. In this way, salt water bodies, originally at certain places deposited, will be displaced and be dispersed

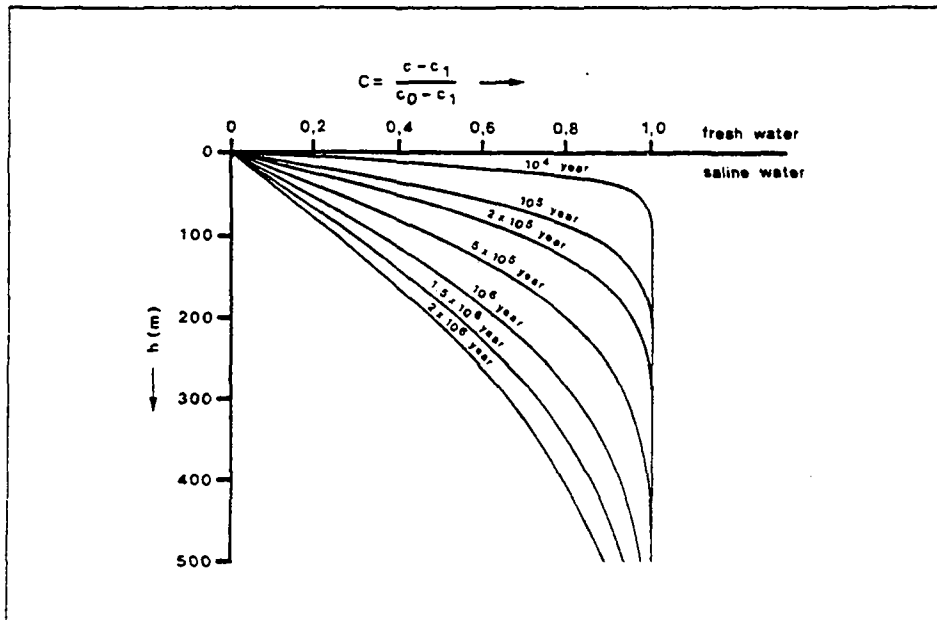

Fig. 4.3.

The effect of molecular diffusion at the desalination of a saline layer by a superimposed fresh layer (C is the relative salinity, C_1 the salinity of the fresh layer and C_0 that of the saline layer)

through the underground. Brackish groundwater may be found where you would not expect it, if ignoring dispersion. The phenomenon of hydrodynamical dispersion is also responsible for the fact that practically never a sharp interface between fresh and saline groundwater will practically never occur in nature; there will always be a transition zone. Hydrodynamical dispersion can be described by mathematical formulas, in practice, however, not without difficulties.

4.5. behaviour of groundwater of varying densities

4.5.1. a sharp interface between fresh and brackish water of constant density

Many geohydrologists have studied the behaviour of fresh groundwater in coastal areas and underneath small islands. In such cases the transition zone between fresh and brackish groundwater is thin; the brackish groundwater will have a

salinity of nearly seawater and it will relatively be at rest. The fresh groundwater may be considered as a lense, floating upon static saline water with a sharp interface in between. The average head in the salt groundwater will everywhere be equal to mean sealevel. Under such conditions and taking into account that pressure of water just below and just above the interface will be equal, the so-called Badon Ghijben-Herzberg relation holds (see figure 4.4.).

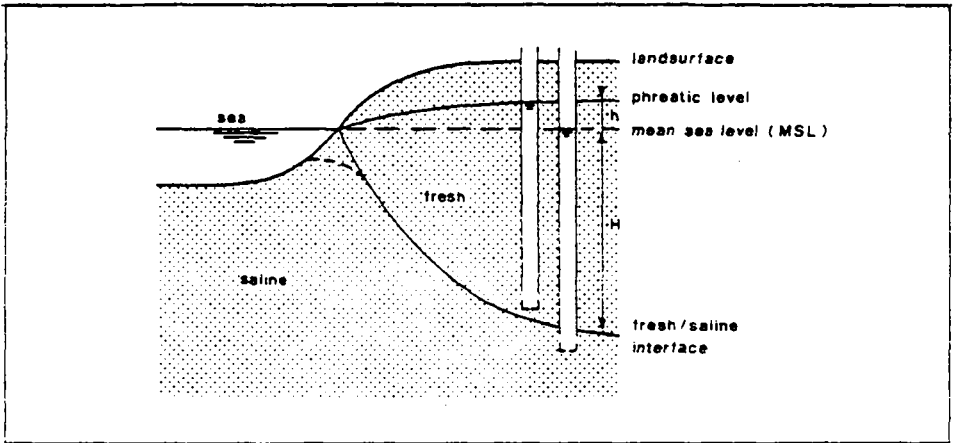

Fig. 4.4.

Different heads in groundwater of different density due to the BGE effect

Note that at the coast the dashed line represents the real situation.

From fig. 4.4. it can be derived that:

$$H \cdot \rho_s = (H + h) \rho_f$$

where:

H = depth of the interface below MSL (m);

h = head of the fresh water above MSL (m);

ρ_s = density of the saline groundwater ($\text{kg} \cdot \text{m}^{-3}$);

ρ_f = density of the fresh groundwater ($\text{kg} \cdot \text{m}^{-3}$).

Reworking yields:

$$h = \frac{\rho_s - \rho_f}{\rho_f} \cdot H$$

For saline groundwater having the same salinity as seawater:

$$\Delta = \frac{\rho_s - \rho_f}{\rho_f} = 0.025 \quad (\rho_s = 1025 \text{ kg/m}^3 \text{ and } \rho_f = 1000 \text{ kg/m}^3)$$

Then it follows also that

$$H = \frac{1}{\Delta} \cdot h$$

$$H = 40 h$$

Hence in words, the depth of the interface will be forty times the head of the fresh groundwater above mean sealevel. For brackish groundwater, having a lower salinity than seawater an appropriate value for Δ should be substituted; it then will appear that the depth of the interface will lie at greater depth. It becomes doubtful, however, if for brackish groundwater of low salinity the Badon Ghijben-Herzberg relation still holds.

The Badon Ghijben-Herzberg relation together with the Dupuit assumptions (see chapter 3) can be used to derive a differential equation for groundwater flow in the fresh lens. An example concerning an infinite strip of land (e.g. a dune ridge) is given below (fig. 4.5.).

The basic equations are:

Darcy: $q = -k (E + h) \frac{dh}{dx}$ (per metre of the strip)

Continuity: $dq = I \cdot dx$

Badon Ghijben-Herzberg: $h = \Delta H$ with $\Delta = \frac{\rho_s - \rho_f}{\rho_f}$

Boundary conditions: $x = 0, q = 0$

$x = L, H = 0$

The differential equation becomes:

$$H \cdot \frac{dH}{dx} = - \frac{I \cdot x}{k (1 + \Delta) \Delta}$$

Elaboration yields the solution:

$$H^2 = I \cdot (L^2 - x^2) / (k(1+\Delta)\Delta)$$

$$h = \Delta H$$

Also for other cases solutions, or (numerical) methods to derive them, are available.

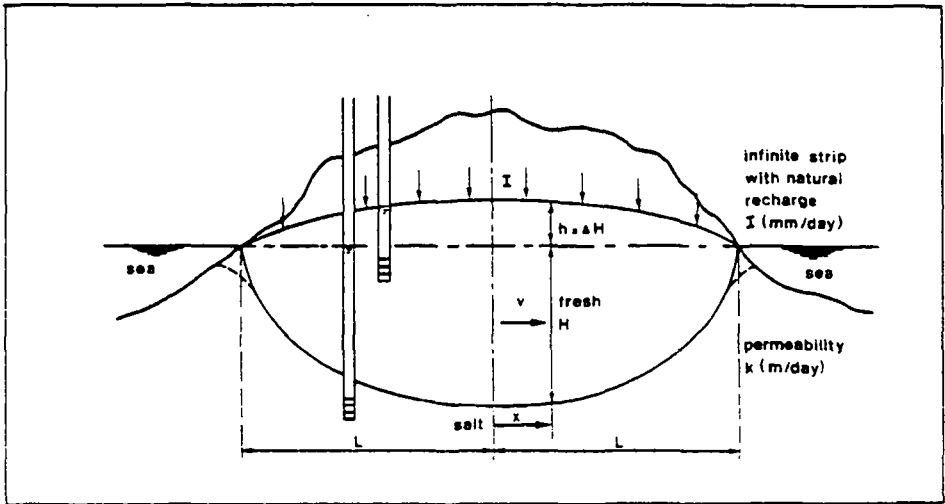

Fig. 4.5.

Fresh groundwater under an infinite strip (phreatic groundwater and one dimensional flow)

4.5.2. flow in groundwater of varying density

When in the underground groundwater of varying density is present, the direction of groundwater flow can no longer be predicted from differences in head, observed in observation wells. Now potential energy conditions of the groundwater are expressed by the pressure equivalent P of the potential. In formula:

$$P = \rho g z + p$$

where

P = pressure equivalent of potential in a certain point ($\text{Pa} = \text{N} \cdot \text{m}^{-2}$);

ρ = density of groundwater in the point (kg m^{-3});

g = acceleration of gravity ($\text{m} \cdot \text{s}^{-2}$);

z = elevation of the point above reference level (m);

p = pressure at the point ($\text{Pa} = \text{N} \cdot \text{m}^{-2}$).

Again the flow of groundwater will be from points of high P to points of low P and no flow will occur along planes where the pressure equivalent of the poten-

tial is constant. Values of P can be easily calculated if head, density and elevation above reference level are known. In doing so for a given observation well, you should realize that the weight of the column of water in the well equals $p/\rho g$, where p is the water pressure at the screen. Theoretically also the rate of flow might be computed, the theory concerned falls beyond the scope of these notes.

5.

groundwater surveys

5.1. the need for investigations

Field- and laboratory investigations have to be planned (type, extent etc.) according to the following considerations:

- What are the objectives of the considered project (What do you want to know = Problem identification) and how do you want to realize them (Strategy)?
- What are the available data (inventorisation), implying both quantity and quality of the data, how can they be used and is that information sufficient. Based on existing data, a preliminary insight has to be obtained into the (geo) hydrological situation of the region or the site (underground, characteristics, etc.).

With the answers to these two questions, it is possible to formulate the necessary additional investigations.

With regard to the type of project, three categories may be distinguished, implying three different types of investigations:

- Regional-scale investigations, considering water resources in view of a future development, be it for irrigation, for public water supply or some other use.
- More or less local scale investigations, directed to the realization of a particular groundwater withdrawal (optimal design in view of yield, quality, draw-down and its consequences).
- General geohydrological investigations, on different scales, on behalf of different objectives (f.e. the cutting of a canal, draining a building site etc.).

5.2. use and interpretation of available data

Available data can be present in the following form:

a. Maps and aerial photographs.

a.1. Topographical maps

Generally, topographical maps, preferably on the largest scale possible (say 1 : 25.000) and containing contour lines, show a wealth of hydrogeological information. The drainage pattern (i.e. the system of ditches, larger canals and rivers, etc.) of the area can be determined, which already gives a clue as to groundwater flow. Shallow groundwater flow will be partly directed to the drainage system and partly follows the direction of the drainage pattern (see fig. 5.1.). When the intensity of ditches, brooks and rivers is high, you can expect shallow groundwater tables, and reversely. In case of shallow water tables, the storage capacity of the underground is low and as a consequence, the drainage system has to be more intensive, to discharge the rainfall excess.

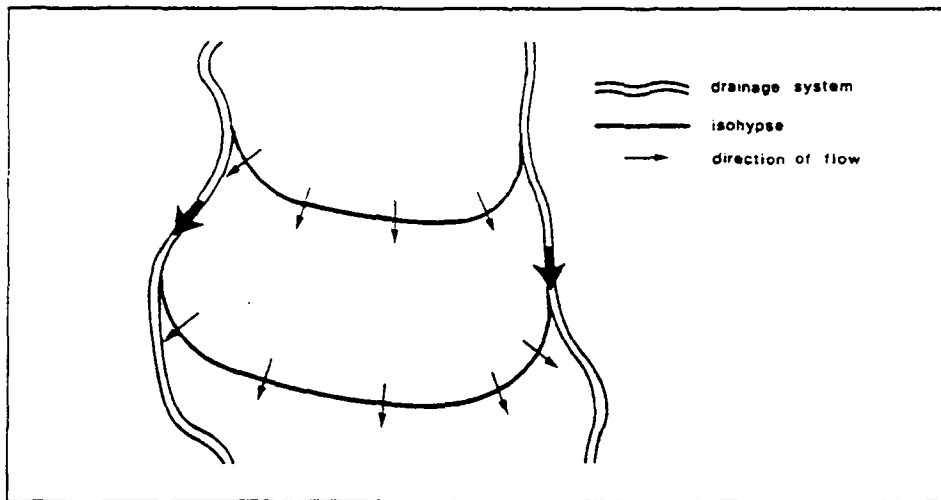

Fig. 5.1.

Direction of flow of shallow groundwater

The contour lines of land surface also give an indication as to direction of flow, which roughly follows the gradients in land surface. Furthermore the elevations in land surface will sometimes disclose geological features. For example elongated elevations in a further flat coastal plane most probably will indicate buried rivers (or river banks) or beach ridges. They may contain local fresh groundwater bodies due to infiltration (see fig. 5.2.).

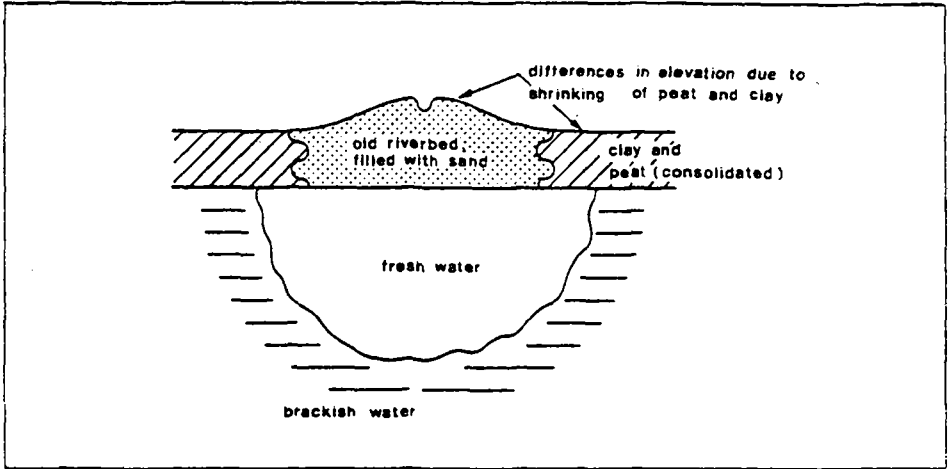

Fig. 5.2.

Elevation in land surface, caused by differences in geological structure

Sudden changes in the pattern of contour lines may mark the location of a fault or a change in the geological structure of the underground. The location of build-up areas and the kind of vegetational cover may also give hydrogeological information. One of the basic needs of man is drinking water; it may therefore be expected that he chooses for his dwelling place areas where good water is available, either in the form of surface water or as (shallow) groundwater. From the vegetational cover indications can be obtained as to the depth of the water table. Coarse textured soils with a deep-lying water table mostly are less suitable for agriculture. They will be covered by forests or be waste lands. If the farmers grow different crops, they also at least partly will follow the groundwater table with their cropping pattern. Meadows will be found in relatively wet areas and agricultural land in the more dry parts. A marsh vegetation indicates a very shallow groundwater table or an impermeable subsoil (see fig. 5.3.).

Information about the soil use (arable land, natural vegetations, ect.) is of great importance. In an area with many human activities, a groundwater withdrawal can be influenced (pollution). A withdrawal however, can also influence the surrounding area (f.e. influencing of crop yield by lowering of the groundwatertable).

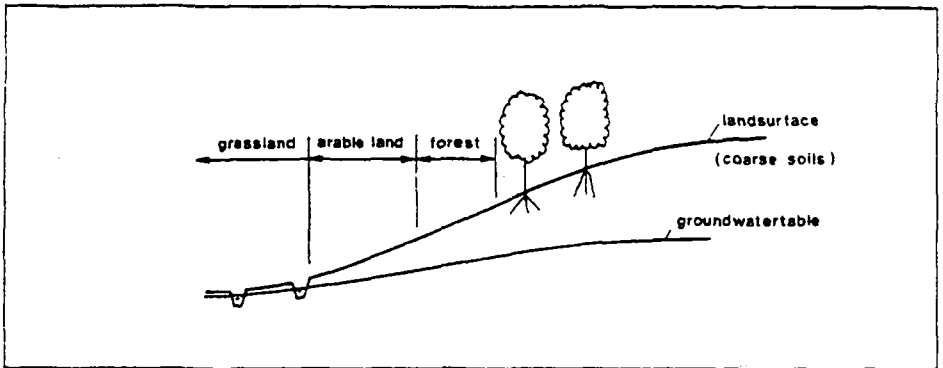

Fig. 5.3.

Possible relationship between the depth of groundwater table and vegetational cover

- a.2. Geological maps. If a geological map exists of the area to be studied it will be of great help for the hydrogeological investigation. If possible, such a map should give in some representative vertical sections an indication about the lithology of the layers present. However, a geological map mostly still has to be completed in hydrogeological respect.
- a.3. Hydrogeological maps. For some areas hydrogeological maps exist, or they are in execution. Generally, such maps should show all the hydrogeological features of the area concerned.
- a.4. Soil maps. Sometimes some kinds of soil maps are available for a certain region. In general, information is given about the composition of the upper 1 or 2 m of the underground (the soil), in relation with its origin. Sometimes, these maps contain information about ranges of groundwater depths.
- a.5. Maps showing special features. Sometimes an area is mapped for one special reason, e.g. to design a future irrigation pattern, or to indicate the type of forest. Also such maps may give valuable hydrogeological information.

a.6. Aerial photographs and satellite imagery

For many areas of the world, the available topographical and other maps do not show sufficient detail to allow for the desired hydrogeological interpretation. In such cases, also aerial photographs may be used, which in some respects even may yield more valuable information than maps. Nowadays the results of satellite imagery, using various photographic techniques, are often available. These may also be helpful. A well-known example of the use of aerial photographs is the delineation of fault systems in hardrock areas. The faults may yield groundwater.

b. Other data.

- b.1. Water quality data. In some cases drainage problems or water supply problems are associated with salinity problems. Hence, data may be available. In other cases quality data have already been collected regarding existing groundwater withdrawals. All these data should be collected.
- b.2. Data on different hydrological parameters. Some governmental departments or institutes keep records on discharges of rivers and brooks, others on meteorological data such as rainfall, evaporation, etc. As far as they could be of help for the hydrogeological investigations envisaged, they should be collected. Since surface water and groundwater in general are interrelated, it is essential that all available data on surface waters be collected.
- b.3. Documents on wells and springs. In most areas to be investigated already some wells will have been executed in the past (exploratory wells for oil, water wells etc.). If such wells have been drilled or supervised by governmental services there is a good possibility that well logs are kept in an archive. In this archive also some data on quality of the water may be present. Sometimes also the contractor in charge of drilling the wells will keep an archive. Also springs have sometimes been measured and the records kept in an archive. Plotting of data on depths of the wells on a map give additional information, for example about existence of aquifers and the position of aquitards.

b.4. Data on borings. Information may be available about the composition of ground and water, obtained from samples, taken from a borehole. More or less detailed information can be available about groundwater heads or -tables, obtained within the framework of different types of investigations. Sometimes this information is available in the form of isohypses or time-groundwater head graphs.

c. Published and unpublished studies on the geohydrology of the area. There are probably only a few areas left in the world which have not been the subject of some hydrogeological study, how rough and how general it may be. Such studies may have been carried out by governmental services, or by private companies. They may have been published in a scientific journal, or they may have remained an internal report. To trace back these studies may be a cumbersome, but mostly also a worthwhile job. Of course, the investigator should start with a search in the specialized libraries and also contact the governmental services and private firms, known to have executed an investigation in the area he is interested in.

d. Interviews with the local people about their means of water supply. Although visiting the existing means of water supply in the area concerned also could be reckoned to belong to the field work to be executed, it might be very useful to make already in the preparatory stage of the investigation a visit to the area. Interviews with the local inhabitants will give much hydrogeological information. The behaviour of the existing wells and springs as to level and discharge fluctuations and information about the quality of the water will be well-known by the users. Furthermore tried and failed attempts to get drinking water will be remembered. Also it is likely that people can be found who have remarked natural phenomena which struck them, such as seepage areas or an unusual vegetational pattern. Moreover, the structure of the uppermost soil layers will be familiar to the farmers.

5.3. additional field and laboratory investigations

Sometimes it is possible to carry out an investigation with available data. In most cases, however, further investigations are necessary, in accordance with the objectives of the project. In the following the most important categories of geohydrological investigations will be mentioned and shortly treated:

a. Hydrogeology

It may be necessary to complete the geological insight in the area concerned. This only can be done by a professional hydrogeologist. However, this expert should be well aware of the problems to be solved, so that he can restrict himself to the kind of study needed.

Exploratory drillings can be necessary to obtain information about the existence and position of aquitards and aquifers, and to learn other properties of aquifers. Drillings are expensive and their sites should be chosen carefully, so that they later can be converted in production wells if possible.

It is necessary to know whether a layer, found in a boring, forms part of a more extensive whole, or that it is a solitary lense of limited dimensions. These questions are to be solved by a geologist.

Geophysical survey at the land surface or in boreholes can give additional information about the structure and geometry of the various layers in the underground.

With all this information and, if possible, with groundwater head observations on different depths, you may try to make a first geohydrological schematization of the underground, in order to make the problem accessible for calculations.

b. Geohydrology

- Measurement of groundwater levels

With data on groundwater levels, insight can be obtained into the geohydrological structure of the underground (distinguishing aquifers and aquitards) and into ground characteristics.

- Determination of ground characteristics

When the geohydrological schematization is established, values must be determined for the ground characteristics of the different layers, to be able to make calculations.

A certain flow pattern is caused by, among other things, the characteristics of the underground. Reversely, you may imagine, that out of the flow pattern information can be derived about the ground characteristics. This can be done in two ways:

- * Making use of natural existing flow patterns, to get insight into the magnitude of the transmissivity, the hydraulic resistance or the storage coefficient.
- * Generating an artificial, temporary flow pattern, by means of a withdrawal of groundwater (so-called pumping tests) and measuring the heads, during a certain period.

- There are several types of laboratory investigations available to obtain information about the permeability of the underground.
 - * Estimation of the permeability, based on the granular composition of soil samples.
 - * Permeameter-tests, making use of Darcy's law (see sections 2.5.3. and 2.5.4.).

In general, the representativity of the results of such investigations is very limited.

- Discharge measurements of various kinds of surface water which are connected with the groundwater system to be investigated. In many cases it will be useful to draw a water budget of a chosen aquifer system. From this budget the various flows of water can be estimated and thereby also an estimate can be made of the available resources to be used for drinking water.

c. Geohydrochemistry

Taking water samples and analyzing them to their chemical composition will make it possible to compose geochemical maps of the groundwater. Such maps may be of much value for a better insight in the connection between aquifer systems, in the flow of the groundwater, in the kind of sediment composing the aquifers etc. Also the investigation of the distribution of fresh and brackish water has to be mentioned here (sampling and geophysical methods).

Summarizing the mentioned categories of investigation, in relation to their goals, we get the following (rough) scheme:

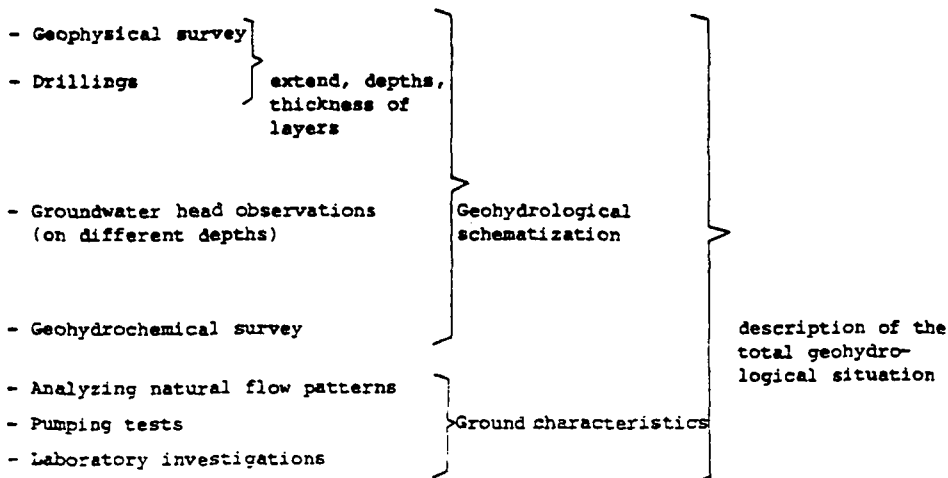

In the following, some important field investigation-categories will be dealt with in some detail.

5.4. geophysical surveys at landsurface

Geophysical surveys at land surface form a relatively quick and inexpensive way - if compared with e.g. drillings - to explore the structure of the underground. That is the reason why geophysical surveys are often applied in the first phase of an investigation. The methods used, however, mostly require specialized professionals to execute the soundings and to interpret the results. The hydrogeologist nevertheless should know the merits of the methods available and therefore we will sketch a few methods used in hydrogeology:

a. Geo-electrical resistivity soundings

With the resistivity method normally an electrical current, generated by an artificial source, is sent through the underground by means of two current electrodes at land surface. The resulting electrical potentials are measured with two other electrodes, also at land surface. Combined with the strength of current applied the apparent resistivity of a part of the underground can be calculated. By varying the distances between either the current electrodes (Schlumberger arrangement, see figure 5.4), or both types of electrodes (Wenner arrangement) different apparent resistivities will be obtained.

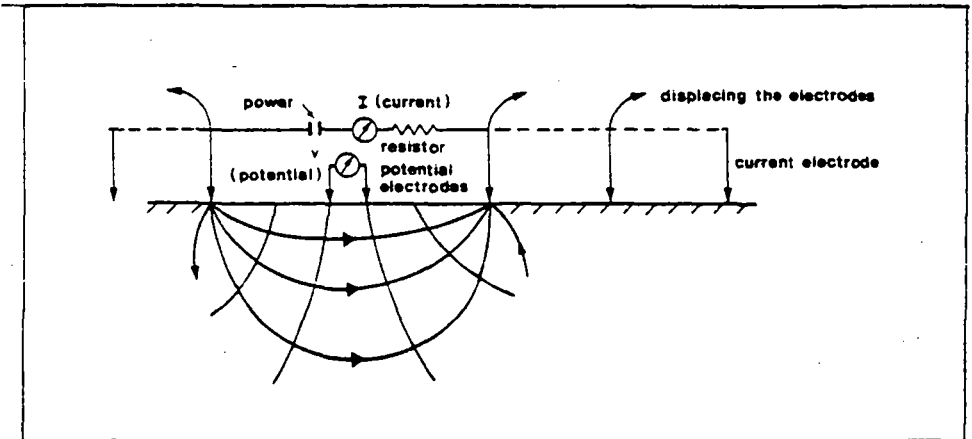

Fig. 5.4.

The Schlumberger arrangement for resistivity soundings

The apparent resistivity depends on the distance between the electrodes, because of variations in the resistivity and the thicknesses of subsequent layers in the underground.

The longer the distances, the deeper the layers involved in transmitting the electrical current. In this way a curve can be composed representing the relation between apparent resistivity and distance between the electrodes. In matching the measured curve with theoretical curves, representing various situations as to thickness, depth and resistivity of layers, the probable structure of the underground can be determined.

Three difficulties may hamper interpretation:

- 1. Suppression. Thin layers at greater depth will not become clearly visible in the measured curve. Its influence will be suppressed by adjacent layers.
- 2. Equivalence. For a given measured curve not one unique solution exists, as generally the combination of thickness and resistivity of a layer will result from the observations. Hence, it may be useful to have available the bore-log of a drilling.
- 3. Influence of water quality. The resistivity of a certain layer is determined by both the resistivity of the ground and of the groundwater. It follows that the resistivity of the groundwater should be known if that of the ground has to be determined.

The resistivity method is very useful in cases where marked differences in the resistivity of underground layers exist. Such is the case in alluvial sediments with an alternation of clay- and sand layers and especially in cases where both fresh and brackish groundwater are present.

b. Electro-magnetic methods

With electro-magnetic methods a time-varying low-frequency electro-magnetic field is generated by a transmitter at land surface. This field will be transformed by any electrical conductor in the underground. A combination of primary (in-phase) and secondary (phase-shifted) signals is then detected by a receiver. Interpretation of results will give a clue as to the structure of the underground. Again, thickness, conductance and depth are important parameters. A difference with the resistivity method is that conducting bodies of limited horizontal dimensions (e.g. buried fractured fault zones) may be more easily discovered. An advantage is that no walking out of electrodes is needed.

c. Seismic methods

Seismic methods make use of the properties of ground with regard to the propagation of seismic waves. The seismic waves are generated by explosions or another instantaneous release of energy to the earth. The arrival of the various waves is recorded by a number of seismometers or geophones on various distances from the so-called shot point. Interpretation of results will yield depth and thickness of layers with different elastic properties in the underground.

Seismic methods are not much used in groundwater exploration, probably because most layers concerned do not have much differing elastic properties. One application is the determination of the depth of the bedrock underneath soft sediments.

5.5. measurement of groundwaterheads

The frequency of observation of groundwater heads depends on the type of study. In a reconnaissance survey, a frequency of once or twice a month will generally be sufficient. To obtain a representative picture of the position of the water table (or head-surface) in the area under study, all the measurements should as far as possible be taken on the same date, for example, on the 14th and 28th of each month. If this proves impossible for whatever reason, the water level of the particular date may, under certain conditions, be estimated by (graphical) interpolation. Another possibility is to use average levels over a given period. If special problems are to be investigated, such as tidal fluctuations, or the effect of heavy rainfall on the groundwater table, the frequency of measurements should be increased to, say, once every hour. If possible, an automatic recorder should also be installed on a representative well.

With regard to the density of the observation network, no general rules can be given as this depends entirely on the topographical, geological and hydrological conditions of the area under study, and on the type of survey (reconnaissance, detailed).

Groundwater flow problems cannot be solved, unless it is known what happens at the boundaries of the flow system. An observation network must therefore extend somewhat beyond the boundaries of the area under study, so as to determine (qualitatively or quantitatively) any inflow from and outflow to adjacent areas.

For a survey of groundwater levels, observations can be made in:

- existing (village) wells;
- open bore holes;
- observation wells (piezometers);
- surface waters (lakes, streams, canals, etc.).

Water level measurements can be taken in various ways:

- Wetted tape method: A chain or steel tape (with calibration in millimetres) to which a weight is attached, is lowered into the pipe or bore hole to below the water level. The lowered length of chain from the reference point is noted. The chain is then pulled up and the length of its wetted part measured (this is facilitated by chalking the lower part of the chain). When the wetted length is subtracted from the total lowered length, this gives the depth to the water level below the reference point (Fig. 5.5A.).
- With a mechanical sounder, consisting of a small piece of steel or copper tube which is closed at its upper end and connected to a calibrated steel tape or to a chain. When lowered into the pipe it produces a characteristic sound upon hitting the water. The depth to the water level can be read directly from the steel tape or measured afterwards along the chain (Fig. 5.5B.).
- With an electric water level indicator, consisting of a double electric wire with two electrodes at the lower ends. The upper ends of the wire are connected to a battery and an indicator device (lamp, sounder). When the wire is lowered into the pipe and the electrodes touch the water, the electrical circuit closes, which is shown by the indicator. If the wire is calibrated, the depth to the water level can be read directly (Fig. 5.5C.).
- With a floating level indicator or recorder, consisting of a float and counter-weight attached to an indicator or recorder (Fig. 5.5D.).
Recorders can generally be set for different lengths of observation period. They require, however, relatively wide pipes.
When artesian groundwater occurs (the piezometric level rises above land surface) the head in observation wells can be measured by means of a flexible tube, attached to a vertically fixed lath or stick.

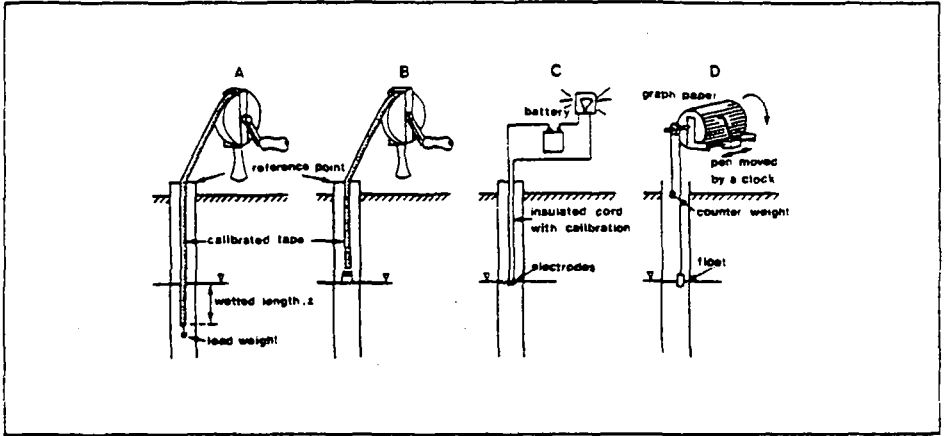

Fig. 5.5.

Methods used to determine depth to water in wells

A: wetted tape, B: mechanical sounder, C: electric water-level indicator and
D: automatic recorder

5.6. pumping tests and well tests

In almost every groundwater survey one or more of the following ground characteristics have to be known:

- horizontal permeability k_h (m/day);
- vertical permeability k_v (m/day);
- transmissivity kH (m^2/day);
- hydraulic resistance c (day);
- leakage factor \sqrt{kHc} (m);
- storage coefficient S (dimensionless);
- porosity p (dimensionless).

There are several methods available to determine values of the ground characteristics, but the most reliable are pumping tests and well tests. There are many variants, but the principle is always the same: you withdraw groundwater at a certain rate from a well which has a screen in the aquifer being tested and you measure at the same time the effects on the groundwater head. Interpretation will result, via analytical formulas describing the governing flow problem, into values for the relevant ground characteristics.

Pumping tests

A, preferably constant, amount of water is withdrawn from a well, during a certain period and the changing heads in the observation wells are measured. Observation wells at several distances of the pumped well have to be available. These observation wells must have anyhow a filter in the pumped aquifer and by preference, also filters in bordering layers (to trace how far the influence of the test works out in the vertical direction). See also fig. 5.6.

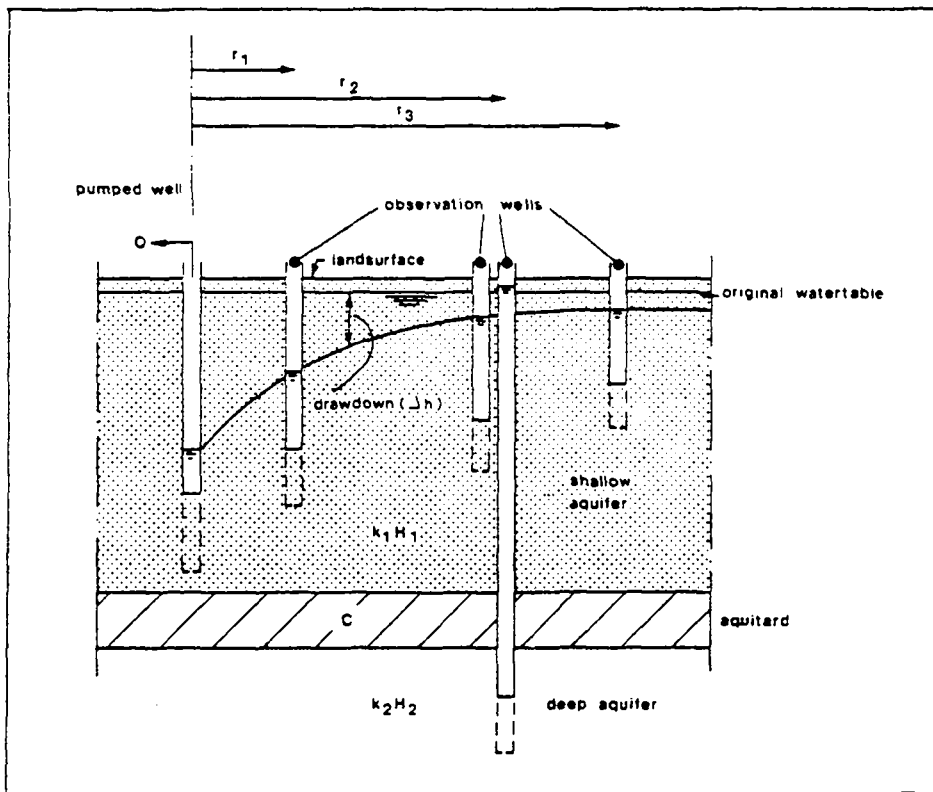

Fig. 5.6.

Set-up of a pumping test

In general, it is recommendable to have a boring available which reaches the base of the aquifer, so that the thickness of the aquifer is known and the permeability k_p can be determined from transmissivity.

Pumping tests produce the relation between discharge (yield of the well) and the resulting drawdowns on varying distances to the pumped well. This relation mostly obeys an analytical formula (the solution of a differential equation), depending on each specific situation. The analytical solution contains the distance and the relevant ground characteristics. So, if the discharge Q is known and also the drawdowns, these characteristics theoretically can be calculated (see fig. 5.6.). The analytical formula that holds in a certain situation, and the values of the ground characteristics, determine the drawdown on a certain moment at a certain place, caused by a certain withdrawal.

So you have to design your pumping test (situation of observation wells, frequency of measurements, period of pumping) based on a rough estimation of the local situation and the ground characteristics.

In the beginning of the test, the drawdown will increase very rapidly, so it is recommended to measure the heads frequently during the first hours of the test, especially in observation wells near the pumped well.

We have to pay attention yet to the particular difficulty that you cannot measure a drawdown in a direct way.

The drawdown is the lowering of the watertable (or the head) with regard to the level, that should have occurred if the pumping test had not been carried out (see fig. 5.7.).

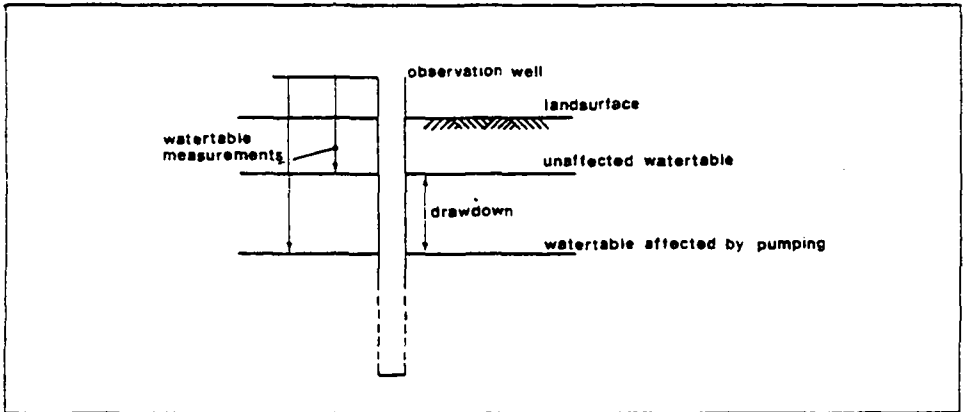

Fig. 5.7.
"Measurement" of drawdown

This level, however, is not a constant level in time, but it is influenced by the weather (rainfall) or by other disturbing factors (for example other withdrawals

in the vicinity, varying levels of surface water, etc.). To calculate the ground characteristics you need drawdowns, caused by the pumping only (see also fig. 5.8.). Hence, it is necessary to eliminate all other influences. Therefore you need a reference well at large distance; the head in this well is allowed to be influenced by the external influences, but not by the pumping. This head is considered to be the level as it should occur in the observation wells if no pumping test was carried out.

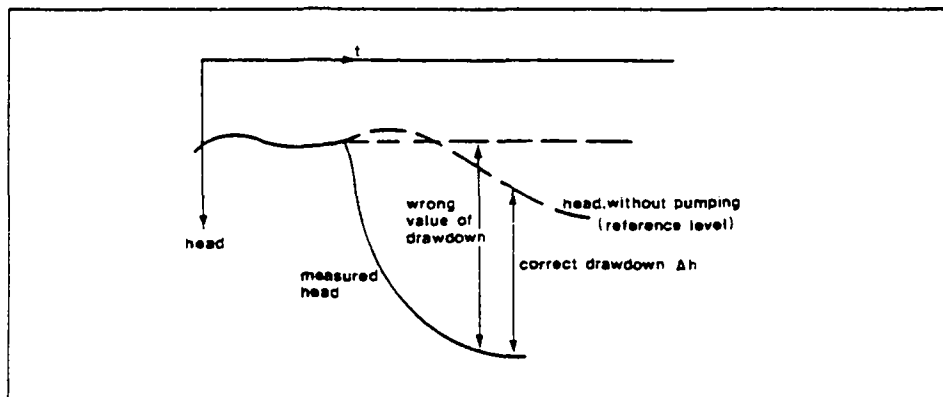

Fig. 5.8.

Determination of drawdown from a head-time graph.

Finally, some remarks about the execution of pumping tests have to be made:

- * The discharge of the pumped well has to be measured.
- * The groundwater heads should preferably be related to a reference level, so that absolute differences in head in vertical direction can be traced.
- * It has to be avoided that the water, discharged by the well, can influence the head in the pumped aquifer during the pumping test.

So you must transport it, via a temporary pipeline, as far as possible from the pumping site, preferably out of the influenced area.

- * Personnel and equipment should be able to reach the site easily.
- * It is recommendable to make a lay-out of the situation, with the different spots of the observation wells, the distances to the pumped well, the discharge point and other relevant information (see fig. 5.9.).

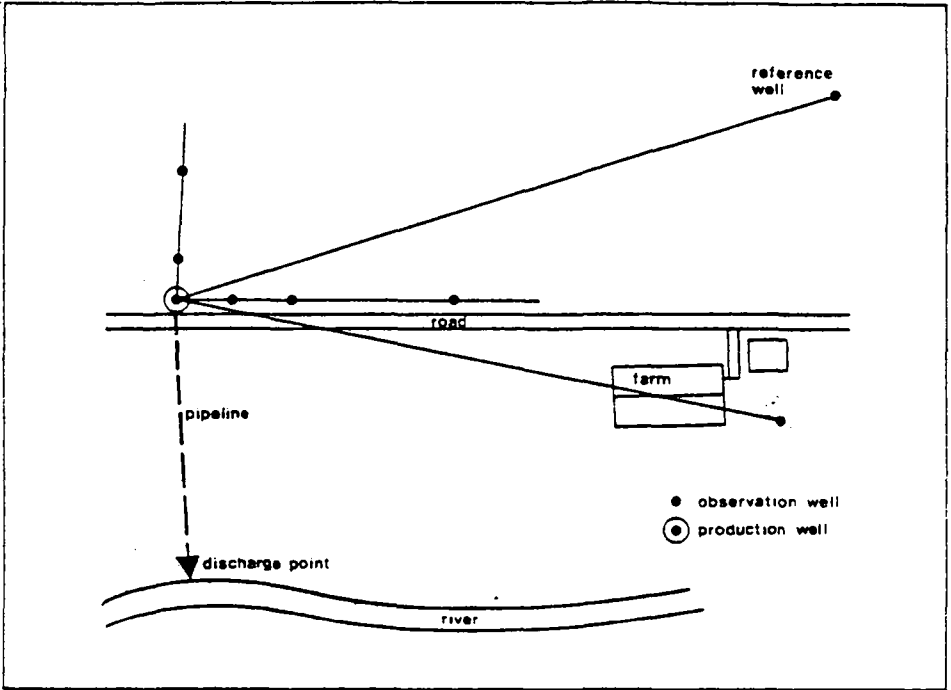

Fig. 5.9.
Possible layout of a pumping test.

Well tests

In well tests there are no observation wells available. Only the measured heads in the pumped well can be used for interpretation. You can carry out a well test in the same way as a pumping test. In general, the only characteristics you can determine with a well test, is the transmissivity kH and, at known thickness of the aquifer H , the horizontal permeability k_h . Generally, the accuracy of results will be less than the accuracy of results of a pumping test. However, carrying out a well test is much cheaper than a pumping test, because you don't need observation wells.

It is sometimes possible to perform a well test on an existing well, although conditions may not be as ideal as when wells have been specially drilled for the purpose.

Analyzing pumping test data

Analyzing pumping test data always results in a determination of the transmissivity kH of an aquifer and, if the thickness H is known, also the horizontal permeability k_h . Furthermore a value of the storage coefficient results. For semi-confined aquifers, it is often possible to calculate a value for the leakage factor L . With L and kH you can calculate a value for the hydraulic resistance c , because $L = \sqrt{kHc}$. To determine values for the vertical permeability and the porosity, it is necessary to carry out the test in a special way. Within the framework of this course, this is a too complicated subject.

After the pumping test has been completed and all basic information has been collected on well discharge, drawdowns in the various piezometers and in the pumped well, trends of the natural changes in hydraulic head, etc.; the data must be processed. This comprises in general:

- compiling the data in the form of graphs;
- correcting the drawdown data for changes of the hydraulic heads in the aquifer not induced by pumping;
- determining the type of aquifer that has been pumped.

In the following, we shall deal with one method for analyzing data of pumping tests in confined and unconfined aquifers (Thiem-Dupuit) and one method for analyzing well test-data.

The assumptions underlying the methods are:

- The aquifer has a seemingly infinite areal extent.
- The aquifer is homogeneous, isotropic and of uniform thickness over the area influenced by the pumping test.
- The aquifer is pumped at a constant discharge rate.
- The pumped well penetrates the entire aquifer and thus receives water from the entire thickness of the aquifer by horizontal flow.

It will be clear that the first assumption in particular is seldom satisfied in nature. However, slight deviations are not prohibitive to the application of the methods. When greater deviations from the above assumptions occur, we come into the field of special flow problems.

A. The Dupuit-Thiem method to analyze pumping tests

Besides the above mentioned assumptions, the following conditions should be satisfied:

- Flow to the well is in steady state.

Attention should be drawn to the fact that steady state has been defined here as the situation where variations of the drawdown with respect to time are negligible, or where the hydraulic gradient has become constant.

- The aquifer is confined or unconfined, but not semi-confined.

When two or more observation wells are available, the transmissivity of a confined aquifer can be determined with the following formula, (see also chapter 3), which is the solution of the differential equation, describing the steady flow to a pumped well in an confined aquifer:

When two or more observation wells are available, the transmissivity of a confined aquifer can be determined with the following formula, (see also chapter 3), which is the solution of the differential equation, describing the steady flow to a pumped well in a confined aquifer:

- $\Delta h_1, r_1$ = steady-state drawdown at distance r_1 (m);
- $\Delta h_2, r_2$ = steady-state drawdown at distance r_2 (m);
- Q = constant well discharge ($m^3 \cdot day^{-1}$);
- kH = transmissivity of the aquifer ($m^2 \cdot day^{-1}$).

Substitution of the values of h_1 , h_2 , r_1 , r_2 , and Q into the equation yields the value for kH .

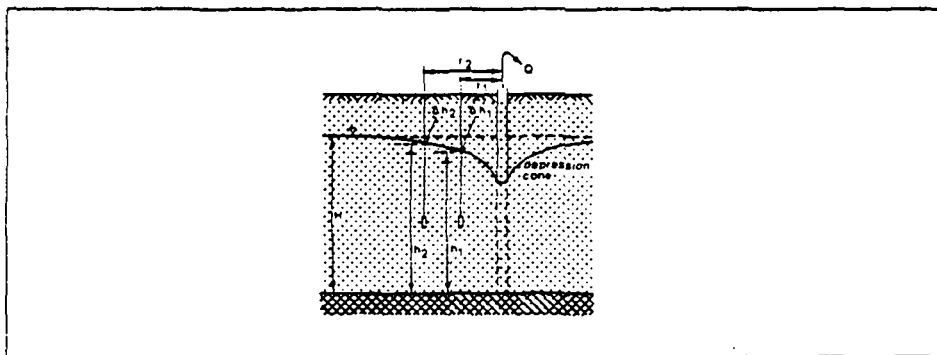

Fig. 5.10.

Observations needed to apply the Dupuit Thiem method.

For unconfined flow the Dupuit-assumptions, listed in section 3.5.3. must be satisfied (among other things, the drawdown should be small in relation to the thickness of the saturated part of the aquifer; otherwise the assumption, that the thickness of the aquifer is constant, is no longer satisfied).

B. Analysis of well-test data

Determination of the transmissivity of an aquifer by means of a well test can take place in cases of horizontal flow to the well-screen. That situation occurs, when the screen-height equals or almost equals the aquifer thickness H . In principle, this method can be applied for every type of aquifer.

You can get the best results with data, obtained during a short recovery period, after a short period of pumping. (In general: a pumping period of approx. 20 minutes and a recovery-period of the same length). Doing so, no problems can occur with the resistance of the well itself (head losses due to entrance of the water into the well), which is a normal phenomenon at well-tests.

After pumping has been stopped, the water level in the well will stop falling and instead, rise again to its original position, this being the so-called recovery of the well. The rise of the water level can be measured as residual drawdown Δh_r ; this is the difference between the original water level prior to pumping and the actual water level measured at a certain moment t'' since pumping stopped (see Fig. 5.11.).

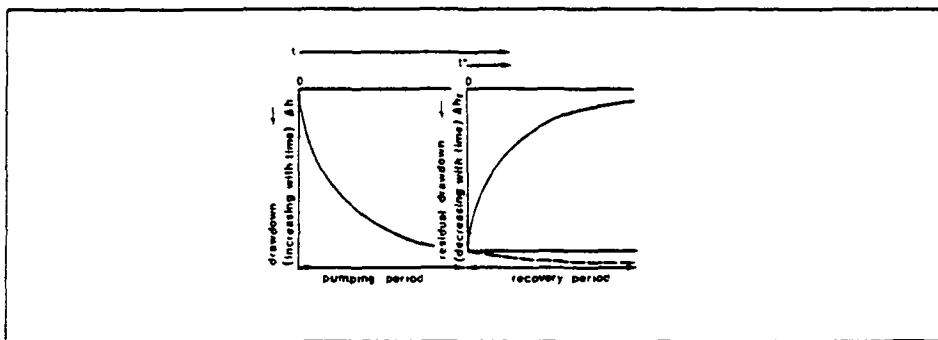

Fig. 5.11.

Schematic time-drawdown / residual-drawdown diagram

By plotting Δh_r (linear scale) versus t'/t'' (on logarithmic scale), where t' is the time since pumping started, and fitting a straight line through the plotted points, Δm can be determined. Δm is the slope of this line (the difference in residual drawdown per log cycle of t'/t'' , see fig. 5.12.). Now, the transmissivity can be calculated with:

$$kH = \frac{2.3 Q}{4\pi\Delta m}$$

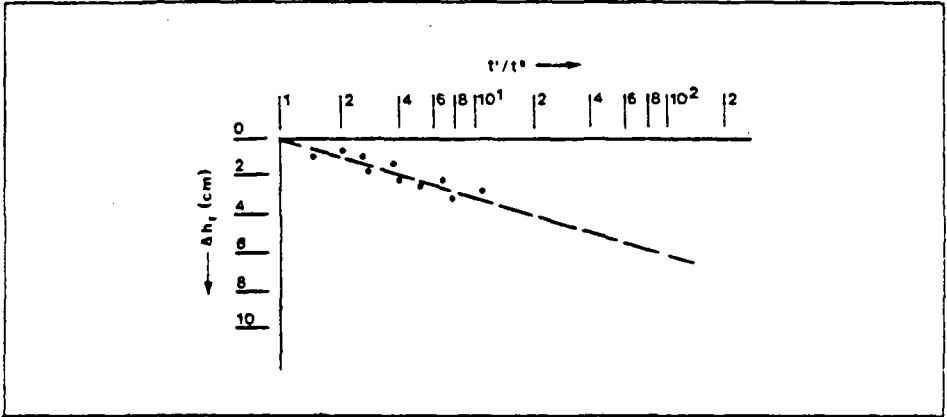

Fig. 5.12.

Representation of test results.

A similar method may also be used when the period of pumping has been very long, for example when stopping a production well. In that case not the residual drawdown has to be observed but the rise of head with regard to the level before stopping. Again, this rise on linear scale should be plotted versus time after stopping on a logarithmic scale (see fig. 5.12) and the slope Δm of the resulting line determined. The same formula as above may then be used to compute the transmissivity kH .

6.

groundwater development

6.1. water resources in relation to water demand

As a source for public water supply, the use of groundwater has some advantages above other water resources:

- Groundwater mostly is hygienically safe; it does generally not contain pathogenic germs.
- If groundwater is present, its availability is practically constant throughout the seasons. No storage facilities are needed.
- Groundwater quality is relatively constant. Notably, the consumers appreciate the constant and relatively low temperature. But also groundwater often has other favourable properties like absence of suspended material, of colour, of taste and smell components.
- If present, groundwater mostly will be available near places of demand. No expensive transport will be needed.

Groundwater also has a few drawbacks. One is that the withdrawal of groundwater from the underground is relatively complicated, because wells or drains have to be installed. Another drawback is the mostly limited availability of groundwater, implying that in cases of high demand - when e.g. used for irrigation or to supply a big town - the availability of groundwater may quantitatively be insufficient. In many cases, however, the advantages will outweigh the drawbacks (see table 6.1.). If you have to search for water resources to fulfil a given demand, first you should consider groundwater possibilities.

The question about groundwater resources can be put in two forms:

1. Regional planners, after having established water demands, may ask for the groundwater resources of a complete region, be it a district, a province or the whole country.
2. The approximate place of withdrawal and the quantity of demand may already be locally fixed; like e.g. at the water supply of a village.

Both cases represent quite different approaches. On a regional scale first the general availability of groundwater should be investigated in terms of favourable and less favourable areas for withdrawal and provisional estimates of total available amounts. Technical means and the exact costs of withdrawal come at the

Table 6.1.

Some effects of different sources of water supply (rural setting)

source	techniques of supply	investment costs per capita	costs of operation and main-tenance	ease of operation	possible constraints
seawater or saline surface water	desalting plant	+++++	+++++	complicated	
	solar still	++++	++	simple	limited capacity
rain water	dams and reservoirs	++++	+++	complicated	topography not suitable
	cisterns	++++	+	simple	limited capacity
fresh surface water	pumping and chemical treatment	+++	++++	complicated	absence of a suitable source
	pumping and slow sand filtration	+++	+++	relatively simple	
brackish ground-water	pumping and no treatment	+	+	simple	limited use
	desalination	+++++	+++++	complicated	
fresh ground-water	spring captation	+	+	simple	no suitable spring available
	shallow wells	+	+	simple	attraction of polluted water
	deep wells	++	++	relatively complicated	upconing of brackish water

+++++ very high +++ moderate + very low

++++ high ++ low

second place. On a local scale often the presence of groundwater has already been established; now the investigation should focus on the design of the best solution to withdraw groundwater (e.g. by shallow wells or by deep wells), including the consequences of withdrawal. The best solution comprises costs of withdrawal, transport and expected treatment of the groundwater. Consequences of withdrawal may be defined in the form of drawdowns and changes in flow, to be interpreted with regard to other interests involved in groundwater. In the following chapters we will give some indications as to the set-up of both types of investigations.

6.2. regional groundwater development

6.2.1. introduction

The availability of groundwater on a regional scale is related to a number of regional properties of groundwater:

- the groundwater reservoir;
- natural and artificial recharge;
- maximum yield of groundwater;
- technical, environmental and economical constraints to withdrawal;
- optimum yield of groundwater.

Hereafter we will define more in detail what is meant by these expressions and what their relation is to the availability of groundwater.

6.2.2. the groundwater reservoir

The groundwater reservoir in a given region at a given time is the total volume of water present in the underground of that region at that time. The upper limit of the reservoir is landsurface and the lower limit is the depth where the rocks do not contain any water anymore. No further distinction is made e.g. between groundwater in aquifers, aquitards or aquicludes. Generally, you will find it difficult to determine the exact volume of the groundwater reservoir; mostly the porosity and the depth of deep water containing layers are unknown. Often, however, the deeper layers are less interesting as they contain brackish or saline groundwater not taking part in the hydrological cycle. More important is the fresh groundwater reservoir.

The lower limit of the fresh groundwater reservoir is the interface between fresh and brackish groundwater (where the chloride content = 600 mg/l Cl^-). The fresh groundwater reservoir has the following characteristics:

- In a natural situation the fresh groundwater reservoir will seasonally fluctuate around a constant average value. Over longer periods the recharge and discharge of the reservoir will be in equilibrium (the storage component in the water balance is zero).
- The volume of the fresh groundwater reservoir may take very high values if thick non-consolidated layers are present. Sand for example has a porosity of about 0.35, implying that every m^3 of sand saturated with water will contain 0.35 m^3 of water. An area of only 1 km^2 with a sand layer of 10 m thick will thus contain 3.5 million m^3 of water.

For the withdrawal of groundwater you may take two positions concerning the fresh groundwater reservoir:

1. Apart from a small initial change the volume of the reservoir is kept unchanged (groundwater as a continuously renewed resource).
2. A more or less large part of the withdrawal comes from a continuous reduction in volume of the fresh groundwater reservoir (mining of groundwater).

The first option implies that groundwater withdrawal cannot exceed the sum of natural and artificial recharge. Hence, there is a maximum to withdrawal. On the other hand the period of groundwater pumping is unlimited. In the second case, when groundwater withdrawal continuously reduces the volume of the fresh groundwater reservoir, the groundwater is mined. The resource will be depleted after a given time and the pumping has to be stopped. It will only in exceptional cases be justified to mine groundwater. If possible, you should always strive at maintaining the fresh groundwater reservoir. In that case the reservoir only has a buffering capacity, influencing groundwater quality and hydrological effects of withdrawal, but not directly the amount of withdrawal.

6.2.3. natural and artificial recharge

Depending on its place in the hydrological cycle each groundwater reservoir has a certain recharge and an, averagely, equal discharge. Recharge and discharge are flows of groundwater to be expressed in volume per time (e.g. m^3/year). For a given area the recharge may also be expressed in terms of a continuously renewed water layer (e.g. in mm/year).

Recharge is the total of all inflowing water, which may come from above or from aside. Three main types of recharge can be distinguished.

1. Groundwater receives recharge from above, because part of the rainfall percolates downward. The area concerned is a recharge area.

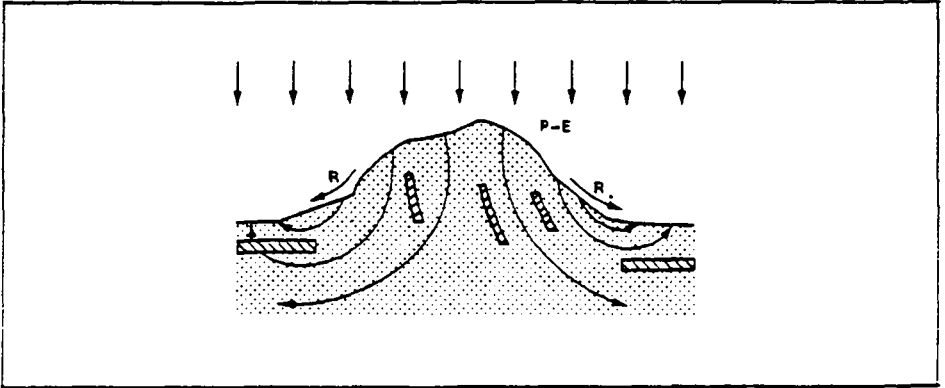

Fig. 6.1.

Recharge from above

Horizontally more groundwater flows out of the area than into it. The water-balance has the form:

$$P - E - R = Q_{\text{out}}$$

(P = precipitation, E = evapotranspiration, R = surface runoff and Q_{out} = discharge by horizontal groundwater flow).

2. No recharge comes from above, but groundwater receives recharge because of an incoming horizontal groundwater flow. Two situations may occur. The first is that groundwater is discharged by only horizontal groundwater flow. The underground only acts as a transport means for groundwater. Mostly, confined aquifers are concerned. The water balance simply is:

$$Q_{\text{in}} = Q_{\text{out}}$$

In the second case groundwater is also, or exclusively, discharged by upward groundwater flow (seepage), to be drained away by brooks or other surface

water. The area is a discharge area and the water balance has the form:

$$Q_{in} = D (+Q_{out})$$

(D = upward seepage, being drained away).

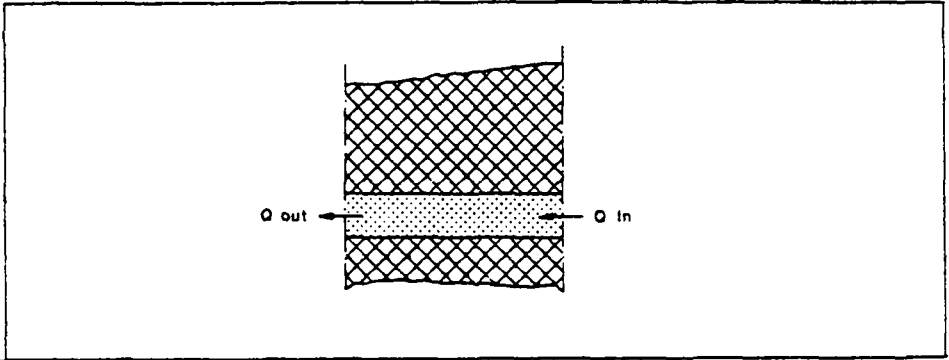

Fig. 6.2.

Horizontal transport

3. Groundwater receives recharge from infiltrating rivers or lakes or other surface water and is discharged by either horizontal outflow, or upward seepage, or both. In such cases the level of river water should be higher than groundwater heads in the adjacent valley, a situation which sometimes occurs near the mouth of rivers.

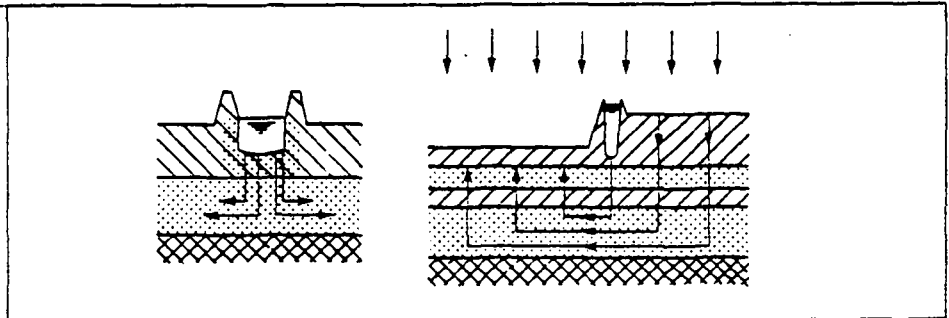

Fig. 6.3.

Recharge from rivers to discharge areas

Mostly if groundwater is recharged by rivers it cannot be fed by rainfall, because the areas concerned will be discharge areas with upward groundwater

flow. The water balance has the form:

$$Q_{\text{river}} = Q_{\text{out}} + D$$

(Q_{river} = infiltration from river bed; Q_{out} = horizontal groundwater outflow and D = upward seepage).

The above water balances hold for natural situations. In all three cases the recharge can be increased by artificial means. In recharge areas an additional recharge can be induced by bringing surface water to the area and forcing it to infiltrate into the soil. In aquifers where only horizontal groundwater transport occurs, additional water may be introduced by recharge wells. Near rivers the groundwater heads may be lowered artificially, thus inducing an increased recharge. The aim of artificial recharge is to increase the possible groundwater withdrawal, without reducing the groundwater reservoir. Surface water temporarily is given groundwater properties, so that increased withdrawal benefits from an improved quality.

6.2.4. maximum groundwater withdrawal and constraints

Under the assumption that the groundwater reservoir remains intact the maximum groundwater withdrawal should not exceed the sum of natural plus artificial recharge. The natural recharge is given for any given area, but also artificial recharge has an upper limit depending on the hydrogeological situation (e.g. because the percolation capacity of the soil is limited). Hence a certain maximum exists to the groundwater withdrawal in a given area.

In practice, artificial recharge will only be applied in special cases. Normally, the maximum groundwater withdrawal is related to the natural recharge only. If all discharge takes place via groundwater abstraction, natural discharge is zero. This theoretical maximum withdrawal generally cannot be realized in practice. A number of constraints will reduce the groundwater available for withdrawal. Three major types of constraints exist:

- a. technical constraints;
- b. environmental constraints;
- c. economical constraints.

- a. Technical constraints. Groundwater has to be withdrawn by technical means like wells, drains, etc. It follows that the geohydrological situation must be suitable to install such intakes. Cases can be imagined where only in part of the area concerned groundwater intakes can be placed and that in the remaining part still a large natural discharge of groundwater occurs. Another technical constraint results from the presence of brackish groundwater. In abstracting fresh groundwater the flow pattern is disturbed and thereby brackish groundwater may enter the intakes. To avoid the attraction of brackish groundwater the yield of fresh water has to be reduced to values smaller than recharge.
- b. Environmental constraints. Fresh groundwater generally forms an active part of the hydrological cycle. Many human activities depend on the hydrological cycle like agriculture, watering of animals and fishery, to mention only a few. If the hydrological cycle is forcedly changed by groundwater abstraction, other interests may be damaged. The rate of damage will determine the importance of the constraint exerted on groundwater withdrawal.
- c. Economical constraints. The economical constraints related to groundwater withdrawal follow from the efforts needed to transform groundwater of given quality at a given place into drinking water of a desired quality at the place of demand.

In the practical situation the optimum withdrawal of groundwater resources can only be a part of the recharge. In The Netherlands for example, groundwater withdrawal is taken to be maximally about 30% of the average recharge.

Optimum groundwater withdrawal in critical situations

Which strategy should you apply if you had to decide on the sources of water supply to fulfil a given demand in a given area? At first look the answer seems to be quite simple. Hydrogeological and geohydrological investigations should reveal the volume of the fresh groundwater reservoir and its average recharge. Places suitable to install groundwater intakes also follow from such an investigation. Somewhat more detailed geohydrological investigations should indicate technical constraints - like presence of brackish groundwater - to withdrawal. Economical constraints follow from a comparison between requirements of demand (place and quality) and expected conditions of withdrawal. A determination of environmental constraints is yet needed and then you may compare the most favourable way of groundwater withdrawal with water derived from other types of water resources.

Indeed, in a non-critical situation where demand forms only a tiny part - say a few percent - of recharge you may simply succeed in this way. Technical constraints mostly will take a simple form in such cases. Moreover, environmental aspects will mostly have a small impact as the disturbance of the hydrological cycle is small. Hence, the problem reduces to a mere economical comparison of alternative possibilities to be solved by relatively simple methods.

The decision becomes complicated in a critical situation where water demand represents a large part of natural groundwater recharge in the area concerned. Firstly, in such cases the technical constraints generally will be complicated (quality changes by withdrawal, large drawdowns etc.). The investigations to determine technical constraints therefore will be time - and money - consuming. This aspect adds to the economical constraints and furthermore an element of uncertainty comes into scene. Even more uncertainty accompanies the environmental consequences, for large withdrawals mostly not to be neglected. In the first place the environmental effects of a significant disturbance of the groundwater part of the hydrological cycle are mostly insufficiently known. But even if an estimate can be made it will contain a number of immeasurable components (e.g. damage to natural reserves). The resulting problem mostly has to be solved by a political decision, not to be taken by technicians alone. We will end here with the remark that the general problem of the optimal groundwater withdrawal in critical situations still is the subject of much research.

6.3. groundwater development on local scale

6.3.1. introduction

In fact most considerations mentioned for regional problems also hold for the local development of groundwater resources. Only the approach is different, if you have to supply groundwater to one given village or town. You need not start with an estimate of groundwater recharge. More important are the technical, environmental and economical aspects of withdrawal. Subsequently, you have to deal with the following items:

- Selection of the exact site of the wells, or the well fields.
- Design of the water intake structures.
- Estimation of the environmental impact.
- Determination of groundwater quality and possible changes after pumping.

From the considerations underlying this investigation, it automatically follows whether withdrawals remain within the limits of recharge or not.

6.3.2. site selection of wells or well fields

Before you can make a choice, regarding the site of the future groundwater intake, you need a rough insight in the geohydrological structure of the underground at and near the place of demand. Sometimes the inventory of available data will already give you this insight, or else you need an additional reconnaissance. Geophysical soundings will be of much help in this phase of investigation, as they represent a relatively cheap and fast method to collect general information.

At the selection of a number of alternative sites for the future water withdrawal the following selection criteria play a role:

- a. The underground should allow for installation of water intake structures, preferably drilled wells, or else dug wells or drains or the like.
- b. The layers to be pumped should contain groundwater of an acceptable quality, which expectedly will not significantly change after long-time pumping.
- c. The distance between withdrawal and places of demand should be as close as possible to reduce transport.
- d. No site should be chosen such that a large environmental impact of withdrawal can be expected.

The above selection criteria give rise to some additional remarks:

a. Possibility to install water intake structures

Generally to withdraw groundwater, permeable layers are needed. In aquifers with a thickness of more than a few metres and consisting of sand, drilled wells generally represent the best technical solution to withdraw water. Drilling can be done by hand if the aquifer is shallow, or else you need a drilling rig. The drilling method should suit the type of underground (percussion drilling for hard rock, rotary drilling for soft rock). Sometimes no extensive fresh aquifer exists; the water has to be drawn from thin layers with fine silty sand, or from a thin layer of fresh groundwater floating on brackish groundwater. Drains are well suited, where a thin layer of fresh groundwater has to be skimmed. The yield per unit length may be low, but the total capacity may be sufficient. Normally, drains are installed at shallow depth in a trench, dug from land surface. In exceptional cases the drains may be installed

in tunnels, dug from a central shaft. Drains are more expensive than drilled wells. They should only be used if no drilled wells can be applied. Dug wells have, due to a much larger diameter, a higher specific yield (yield per meter drawdown per meter screen length) than drilled wells. Therefore they can sometimes be used in thin and less permeable layers in cases of small demand; their total yield mostly will be small.

b. Groundwater quality to be expected

Groundwater quality at the selected sites should be known, either by previous observation or else by analysis of samples. Groundwater quality may deteriorate by pumping. Examples are attraction of brackish groundwater, or of polluted water from above. Preferably the site of withdrawal should be upstream of sources of pollution. Clearly you will come into trouble if you install a shallow well very near to e.g. a sanitary latrine.

c. Distance between withdrawal and place of demand

Some transport of the groundwater pumped will always be necessary. At larger distances, however, transport costs will become predominant in the total costs of the water delivered. Only after careful examination of transport costs versus other arguments you should choose a more far-off site.

d. Environmental impact of withdrawal

Especially the larger withdrawals mostly will have some environmental impact. Sites where a large influence on other interests can be expected, should be avoided.

6.3.3. *design of pumping wells*

6.3.3.1. *general*

In 99 out of 100 cases the intake structure for groundwater abstraction will consist of a drilled well. Therefore we will discuss in some detail the design of drilled pumping wells. The main elements of a drilled shallow well are shown in figure 6.4. Deeper wells to be provided with a mechanical pump, either of a suction type (pump at the surface) or of a pressure type (deepwell pumps or underwater pumps) will essentially show the same characteristics.

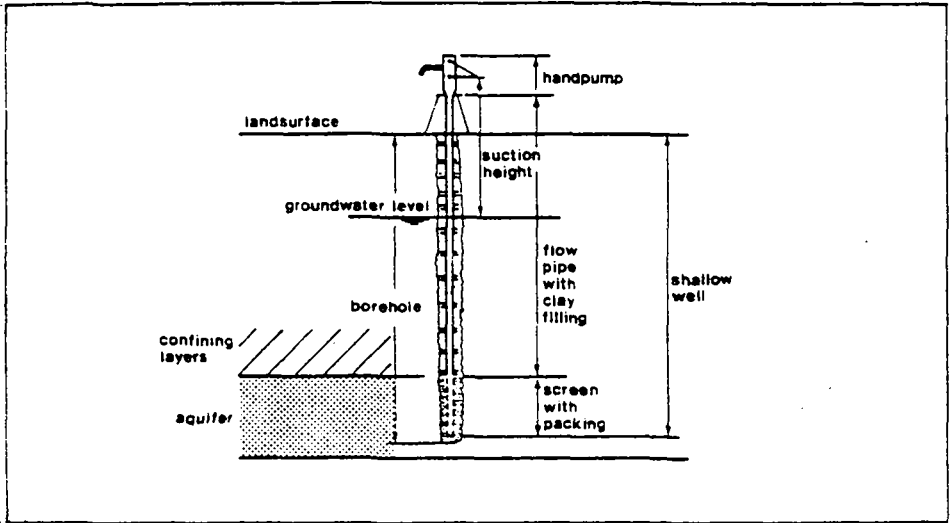

Fig. 6.4.

Terminology of underground parts of a shallow well with handpump

In the following the possible causes of failure of a well will be treated and how to avoid them. Some common cases to be encountered can already shortly be mentioned:

- a. Wrong screen implantation. The pump gives only a small amount of water because the filter is not placed in a water bearing layer.
- b. Clogging of the screen. The well does not yield water after some time because the screen has been filled with sand and silt.
- c. Too low water levels during part of the year. Due to the variation in groundwater level during the year the suction height of the pump may become too large so that no water can be withdrawn. In other cases the water level may even drop below the screen.
- d. Bad quality of the water. The water pumped is not used by the potential consumers because of its bad taste or smell. Even more dangerous is a pollution with pathogenic organisms, because they mostly will not be recognized by the users of the well.

- e. Corrosive action of the groundwater, leading to an increased deterioration of the whole structure.

Of all the aspects pertaining to drilled pumping wells, we will only treat a few, namely construction of the well, drawdown in the well and the yield of wells.

6.3.3.2. *construction of the well*

The screen and the flow pipe are mostly placed in a borehole with a somewhat larger diameter. It is important that the non-screened parts of the borehole be filled up with less permeable material (clay) in order to prevent downward soaking of polluted water from land surface.

A more complicated problem is formed by the design of the proper well screen and its surroundings. It is by no means sure that even in the best aquifer any screen will do. On the contrary, the chance of a quick clogging of the screen will be great if no care is taken to adjust the screen construction to the sandy aquifer concerned. Moreover, when the aquifer contains an appreciable fraction of finer material (fine sand and silt) a gravel packing around the screen is necessary to avoid a sand- or mudpumping and ultimately a non-yielding well. A gravel pack has to consist of carefully sieved very uniform quartz sand or gravel. Anyhow the application of a gravel packing will increase the yield and the life-time of every well. However, the installation of a gravel pack is expensive (because a large borehole is needed and the gravel material is expensive in itself) and great care should be taken for proper execution. The following rules can be followed at the design of a well screen without or with a gravel packing and subsequent development of the well.

a. Non-gravel packed or naturally developed wells.

To determine the size of the well screen slot, when no gravel-packing is applied, a sieve analysis of a representative sample of the aquifer material has to be carried out. For such a sieve analysis a set of sieves with various widths of the opening is necessary (such sets of sieves are commercially available). The sample is first sieved through the sieve with the largest openings and the quantity of sand retained on the sieve is noted. Thereafter the sieve with the second largest opening is taken, the result noted and so on. With the results a sieve analysis graph can be composed. The diameter of

the sieve openings and the percentages (in weight) of the total sample, retained on each sieve give a point in the graph (see fig. 6.5.).

The smooth line connecting all the points is called the sieve-curve. The size of the screen opening is now selected such that the screen will retain from 40 to 50 percent of the sand of the aquifer. Or, with other words, 50 to 60 percent of the surrounding aquifer particles will pass the screen during development of the well (see hereafter). For the example of fig. 6.5., a screen with openings of 1 mm would be appropriate for curve a.

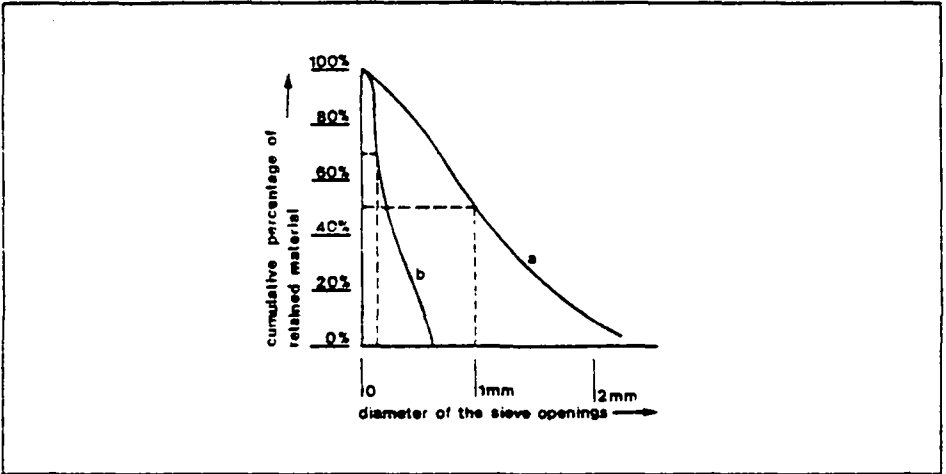

Fig. 6.5.

Example of a sieve analysis graph.

Curve a represents coarse sand, gravel packing is not necessary.

Curve b represents fine sand, gravel packing is necessary.

Note: Sometimes it is useful to plot the sieve openings on a semi-logarithmic scale.

The sand with curve a of fig.6.5 is composed of relatively coarse material. For finer grains a smaller slot size is necessary. However, it is not advisable to use slot sizes smaller than 0.5 mm as then the danger of clogging by chemical incrustation or bacterial growth becomes too great. Therefore, in aquifers consisting of fine sand a gravel pack is needed.

b. Wells where a gravel pack is applied.

The sand represented by curve b in fig.6.5 is too fine for a well without a packing. The gradation of the packing material should be determined such that

only a minor percentage (usually 30% is taken) of the aquifer material can pass through it. This aim is reached when the smallest grains of the gravel pack have a diameter which is 4 to 5 times the diameter of the largest grains of the above 30% of aquifer material, which is allowed to pass the pack; in fig. 6.5 this diameter is represented by the 70% retained percentage. Hence, for the example of curve b the smallest fraction of the gravel pack should have a diameter of 0.5 mm. All of the gravel pack should be retained by the screen slots, so the slot size should be also 0.5 mm. In case of a very fine sand it may be necessary that between the screen and the first gravel pack a second gravel pack is applied to avoid that the slot size would become too small. However, the thickness of the total gravel pack should not exceed 8 inches, whereas the lower limit is a thickness of 2 inches.

b. Development of the well.

Maximum benefit from an installed well is only obtained if the well is properly developed. For a non-gravel-packed well, development may even be considered a necessity. Development consist of pumping the well, by a special pump, first with a small capacity (say 20% of the expected discharge during use) and then with a stepwise increasing capacity, till the capacity is some 1.5 times the expected capacity. If possible, every now and then the flow of water should be reversed. The results of such development will be (see also fig. 6.6.):

1. Correction on damage or clogging of the aquifer resulting from drilling methods (sometimes a mudcake is formed alongside the borehole with rotary drilling methods).
2. Increase in porosity and permeability of the aquifer in the surroundings of the well.
3. Stabilization of the sand around the screen or the packing, so that the well will not yield sand or mud during exploitation.

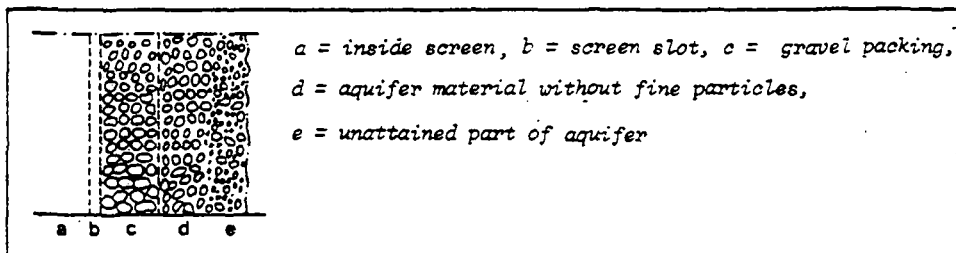

Fig. 6.6.

The result of development

6.3.3.3. drawdown in the well

The drawdown in pumped wells mainly comprises two components, the first resulting from the geohydrological situation in the surroundings of the well and the second from the resistance to water flow of the well construction itself. You can derive the drawdown induced by the geohydrological situation by the methods proposed in the chapter on Fundamentals of groundwater flow.

The appropriate formula mostly will have a form like:

$$\Delta h = \frac{Q}{2\pi kH} \cdot W(u)$$

(Δh = drawdown, Q = well discharge; kH = transmissivity; $W(u)$ the appropriate well function, dependent on a.o. distance to the well).

By substituting the radius of the well - the radius of screen plus packing - you will find the drawdown holding for the outer diameter of the well. To this value first the drawdowns caused by other wells in the vicinity and determined with the same formula should be added. Thereafter a drawdown caused by well resistance should extra be added to find the ultimate drawdown in the well.

The well resistance mainly depends on two factors, namely the rate of penetration of the well in the aquifer and the occurrence of friction losses in packing, well screen and flow pipe. A well is partially penetrating if not the full height of the aquifer is screened - at thick aquifers a cost reduction results from partial penetration. Partial penetration causes curvilinear flowlines near and underneath the well and hence an additional drawdown. Formulas exist to describe this effect, depending on well discharge and on geometrics of penetration. Contrarily, you cannot determine the resistance due to friction losses beforehand; it largely depends on the actual construction of the well. Therefore you need a well test in which after some (say four) hours of pumping the well discharge and well drawdown are observed and the specific yield of a well is determined. The specific yield is the drawdown per unit discharge per full well or alternatively per one metre of the screen after some (4) hours of pumping.

Normally at the start of pumping the drawdown caused by friction losses will be much smaller than the drawdown caused by the geohydrological conditions. After prolonged pumping, however, the resistance of the well may increase due to clog-

ging of the packing or the screen. Clogging may, apart from attraction of mud and other fine particles, also be caused by chemical or microbiological processes. These last causes cannot always be prevented. Then a dangerous situation occurs as it may be expected that clogging will continue at an ever faster rate. In case of clogging a number of regeneration methods have been developed, dependent on the type of clogging. These methods, however, are expensive; in severe cases it will even be better to abandon the well. An increase of the well resistance may be observed when an observation screen is available in the gravel packing. An increasing difference in drawdown between the observation well and the pumping well gives an indication as to increasing well resistance.

6.3.3.4. *the yield of wells*

To determine the maximum yield of wells you may use two criteria:

- 1. The inflow velocity at the screen.
- 2. The drawdown in the well.

In the past some investigators have tried to establish a relation between inflow velocity, permeability of the aquifer and clogging of the well by fine particles. As a result they have proposed formulas where the maximum inflow velocity and hence the maximum well discharge are a function of permeability of the aquifer. In later years, however, other investigators discovered that at a proper design and execution of the well construction practically never a clogging with fine particles will occur. On the other hand, other types of clogging might also be related to inflow velocity. Not enough field studies have been done, however, to establish a design criterium.

The maximum drawdown to be allowed in the well depends on each particular situation. Examples as to the drawdown in the well being a limiting factor are:

- a. In cases where a suction-type pump at land surface (e.g. a suction handpump) has to pump the water, the suction height should not exceed theoretically 10 m, but in practice not a depth of 6 to 7 meters. Hence the groundwater-level in the well should not drop beyond 6 to 7 m below the pumphouse. In many situations the average level in the well already may be some metres below land surface and furthermore seasonal fluctuations of another 2 to 3 meters may occur. Hence, not much additional drawdown due to pumping can be allowed in such cases. A practical consequence is that in using a suction type pump, you must be well aware of the lowest possible water level to occur in the well.

- b. The water level in the well should not drop to a lower level than the place of the opening of the pump if an underwater pump is used or else the pump will attract air and possibly get damaged. Especially in shallow aquifers the pump opening may have a relatively high position. Hence, you should also here take good care of the lowest possible water level in the well under extreme conditions. You may choose the solution to locate the underwater pump within the well screen to gain some depth. This situation, however, has the drawback that part of the well screen may temporarily fall dry. In some cases this will lead to an ever increasing chemical clogging of the well.
- c. If a partially penetrating well is located above a brackish water body in the same aquifer, the drawdowns in the well should be limited to about half the original distance between the base of the well and the top of the brackish water, to avoid upconing. Elaboration yields the maximum discharge of the well concerned.

6.3.4. estimation of the environmental impact of pumping groundwater

Withdrawal of groundwater affects the hydrological cycle and thereby it may have consequences for other interests involved with groundwater. Generally one or more of the following effects may result from pumping:

- a. Lowering of the groundwater head in the vicinity of the well may affect the yield of other wells. Shallow (dug) wells may fall dry; freeflowing artesian wells may stop flowing; in wells with a suction pump the suction height may exceed 6 to 7 m.
- b. Lowering the phreatic groundwater level may cause damage to agricultural crops or the natural vegetation, if they, in dry seasons, also have to rely on groundwater. This situation only occurs at shallow groundwater tables where the roots of plants can reach the capillary fringe above the phreatic level.
- c. Lowering of groundwater heads will result in an increase of grain pressure and thereby may result in a significant compaction of soft groundlayers and notably peat and clay. Compaction or consolidation of the underground will cause land subsidence. Cases can be cited where land subsidence due to groundwater pumping took excessive forms (Mexico City, Venice).
- d. A decrease of natural groundwater discharge will cause a decrease in the discharge of natural springs, brooks and small rivers. This decrease will be felt by other uses of the surface water concerned, amongst others by a deterioration of water quality (less dilution).

It follows that you should obtain first a detailed insight in the changes of groundwater head in the vicinity, not only in the aquifer itself but also in superimposed layers, to estimate the environmental impact of groundwater withdrawal. Especially the determination of drawdowns in a multi-aquifer system will cause trouble. As already has been stated, even more difficulties arise at the evaluation of environmental changes due to the lowering of head. Nevertheless an attempt should be made.

6.3.5. changes in groundwater quality

Due to groundwater pumping the groundwater flow field will change. Hence groundwater having an undesired quality may be attracted by the wells concerned. We already mentioned the case of an upconing of brackish groundwater from deeper layers. Special attention should also be given to the possible attraction of polluted water from above. To this end you have to determine direction and rate of flow. In practical cases you may use simplifying, but safe, assumptions to define a protection zone around the well or the well field based on residence times. In such zones no polluting activities, eventually causing a deterioration of groundwater quality, should be allowed.

appendix A

Conversion factors for some much used units in (geo)hydrology according to ISO standards

Length (also depth of rainfall or evapotranspiration)

Inch	1 in.	= 0.0254 m = 25.4 mm
Foot	1 ft.	= 12 in = 0.3048 m = 304.8 mm
Yard	1 yd.	= 3 ft = 0.9144 m
Mile	1 mile	= 1609 m = 1.609 km

Area

Acre	1 acre	= 4047 m ²
------	--------	-----------------------

Volume

Liter	1 l	= 0.001 m ³
U.S. gallon	1 U.S. gallon	= 3.785 l = 0.003785 m ³
Imperial gallon	1 Imp. gallon	= 4.546 l = 0.004546 m ³

Temperature

Degrees Celsius	a °C	= (a + 273.15)K
Degrees Fahrenheit	b °F	= (b-32) .5/9 °C = (5/9b + 255.37)K

Mass

Pound	1 lb.	= 0.454 kg
Ounce	1 oz.	= 0.02835 kg
Grain	1 gr.	= 0.0648 . 10 ⁻³ kg

Weight (force)

Kilogramforce	1 kgf	= 9.8 N (Newton)
Poundforce	1 lbf	= 4.5 N

Pressure

Newton/meter ²	1 N/m ²	= 1 Pa (Pascal)
Atmosphere	1 atm.	= 1.013 . 10 ⁵ Pa
Meter water column	1 m.w.c.	= 9806.65 Pa

<u>Discharge</u>		
Cubic metre per hour	1 m ³ /h	= 24 m ³ /day = 2.777.10 ⁻⁴ m ³ /s
Cubic feet per second	1 cfs	= 28.3 l/s = 0.0283 m ³ /s
Imp. gallon/day	1 I.G.D.	= 5.262 m ³ /s
U.S. gallon/day	1 U.S.G.D.	= 4.381 m ³ /s

<u>Velocity (flow density, hydraulic conductivity)</u>		
Meter/day	1 m/day	= 1.157.10 ⁻⁵ m/s
U.S. gallon/day/feet ²	1 U.S. gal/day-ft ²	= 4.716.10 ⁻⁷ m/s
Imp. gallon/day/feet ²	1 Imp. gal/day-ft ²	= 5.663.10 ⁻⁷ m/s

<u>Transmissivity</u>		
Meter ² /day	1 m ² /day	= 1.157.10 ⁻⁵ m ² /s
U.S. gallon/day/feet	1 U.S. gal/day-ft	= 1.437.10 ⁻⁷ m ² /s
Imp. gallon/day/feet	1 Imp. gal/day-ft	= 1.762.10 ⁻⁷ m ² /s

<u>Water quality</u>		
Part per million	1 p.p.m.	= 1 mg/l = 1 g/m ³
Part per billion	1 p.p.b.	= 1 µg/l = 0.001 g/m ³
Grain per gallon	1 gr/U.S. gal	= 17.1 mg/l = 17.1 g/m ³

appendix B

Further reading

1. BEAR, J.
Dynamics of fluids in porous media
American Elsevier Environmental Science Series. New York, 1971.
2. DAVIS, S.N. and R.J.M. DE WIEST
Hydrology
New York, Wiley, 1966.
3. GROUNDWATER and WELLS
A reference book for the water-well industry
Published by Edward E. Johnson Inc. Saint Paul, Minnesota.
4. Guide to Hydrometeorological practices
World Meteorological Organization
W.M.O. No. 166. T.P. B2.
5. HEM, J.D.
Study and Interpretation of Chemical Characteristics of Natural Water
U.S.G.S. Water Supply Paper no. 1473, 1970.
6. HUISMAN, L.
Groundwater Recovery
MacMillan, 1972.
7. KRUSEMAN, G.P. and RIDDER, N.A. de
Analysis and evaluation of pumping test data
International Institute for Land Reclamation and Improvement (ILRI)
Wageningen, 1970
Bulletin 11.
8. PRICKETT, T.A.
Modelling techniques for groundwater evaluation
In: Advances in Hydroscience; ed. by Ven Te Chow, New York, Academic Press,
1975, Vol. 10, p. 1-143.

9. **STEADY** flow of groundwater towards wells; Compiled by the Hydrological Colloquium, The Hague, Committee for Hydrological Research TNO, 1964
Proceedings and Informations No. 10.

10. **SURVEYS and Investigations**
Edited from: Lecture notes of the International Course on Land Drainage Wageningen, ILRI, 1974
Drainage principles and applications, Publication 16, Vol. III.

11. **TELFORD, W.M., GELDART, L.P., SHERIF and KEYS, D.A.**
Applied Geophysics
Cambridge, University Press, 1976.

12. **THEORIES of field drainage and watershed runoff.**
Edited from: Lecture Notes of the International Course on Land Drainage. Wageningen. ILRI, 1973
Drainage principles and applications, Publication 16, Vol. II.

13. **VERRUIJT, A.**
Theory of Groundwater Flow
MacMillan, 1970.

14. **WALTON, W.C.**
Groundwater Resource Evaluation
McGraw-Hill, 1970.

IRC publications

IRC publishes a Technical Paper Series which provides expertise on selected topics in water supply and sanitation. These documents usually are produced as a joint effort of expert consultants, specialist contractors and IRC staff.

IRC Technical Papers are designed for selective use by various levels of staff engaged in water supply and sanitation, not only professional engineers and decision-makers, but also planning staff, public health officers and technicians.

IRC also publishes a Bulletin Series comprising reports of international expert meetings and seminars organized by IRC, and an Occasional Paper Series, in photocopy format, which presents ongoing work at IRC and related organizations.