



**WATER AND SANITATION  
PROJECT**

205.2

86 FR

CDM and Associates

Sponsored by the U.S. Agency  
for International Development

1611 N. Kent Street, Room 1002  
Arlington, Virginia 22209 USA

Telephone: (703) 243-8200  
Telex No. WUI 64552  
Cable Address WASHAID

# FRAMEWORK AND GUIDELINES FOR CARE WATER SUPPLY AND SANITATION PROJECTS

WASH  
IS  
A  
PROJECT  
OF  
THE  
U.S. AGENCY  
FOR  
INTERNATIONAL  
DEVELOPMENT  
WASHINGTON, DC

## WASH TECHNICAL REPORT NO. 40

JUNE 1986

The WASH Project is managed by Camp Dresser & McKee International Inc. Principal cooperating institutions and subcontractors are: Associates in Rural Development, Inc.; International Science and Technology Institute, Inc.; Research Triangle Institute; Training Resources Group; University of North Carolina At Chapel Hill.

Prepared for  
**CARE, New York**  
at the Request of AID's Office of Health,  
**Bureau for Science and Technology**  
**WASH Activity No. 139**



WASH TECHNICAL REPORT NO. 40

**FRAMEWORK AND GUIDELINES FOR CARE WATER SUPPLY  
AND SANITATION PROJECTS**

Prepared for CARE, New York, at the Request of AID's  
Office of Health, Bureau for Science and Technology,  
under WASH Activity No. 139

by:

Raymond B. Isely  
Scott Faiia  
John Ashworth  
Richard Donovan  
James Thomson

June 1986

SEARCHED  
SERIALIZED  
INDEXED  
FILED  
JUN 11 1986  
FBI - WASH DC  
6735 ISN = 2416  
205-2867R

Water and Sanitation for Health Project  
Contract No. 5942-C-00-4085-00, Project No. 936-5942  
Is sponsored by the Office of Health, Bureau for Science and Technology  
U.S. Agency for International Development  
Washington, DC 20523

\$\$\$\$\$\$\$\$\$\$\$\$\$\$\$\$

In Memoriam

On June 27, 1986, Raymond B. Isely died following an extended illness that eventually overcame his body but failed to conquer his enthusiasm for his work. His co-authors wish to acknowledge the contribution and inspiration of Dr. Isely in the preparation of this manual and in many other activities involving water, sanitation, and public health.

\$\$\$\$\$\$\$\$\$\$\$\$\$\$\$\$

## Table of Contents

Chapter	Page
ABBREVIATIONS.....	vii
<b>PART I: FUNDAMENTALS</b>	
1. THE PURPOSE AND SCOPE OF THESE GUIDELINES.....	1
1.1 An Overview of CARE's Community Water Supply and Sanitation Activities.....	1
1.2 Water Supply and Sanitation.....	1
1.3 The Purpose of the Guidelines.....	2
1.4 Guideline Applications.....	3
1.4.1 New Projects.....	3
1.4.2 On-going Projects.....	4
1.4.3 Training Staff.....	4
2. BROAD POLICY ISSUES IN PLANNING AND IMPLEMENTING WATER SUPPLY AND SANITATION PROGRAMS.....	5
2.1 Who Should Decide on the Purpose and Approach of a Project?.....	5
2.1.1 Political Actors and Technical Experts Usually Dominate..	5
2.1.2 Local Participation is Key to Project Success.....	7
2.2 Water Quality Versus Water Quantity and Accessibility.....	10
2.2.1 Health Benefits Traditionally Emphasized.....	10
2.2.2 Focusing on Benefits that Users Themselves Define.....	10
2.3 Sanitation Considerations.....	12
2.4 Health Education--A Problem of Definition.....	13
2.5 Anticipating Problems in Systems Operation, Management, and Financing.....	13
2.5.1 Organizing Users to Deal with Maintenance Problems.....	14
2.5.2 Minimize Reliance on Resources Outside the Community.....	14
2.6 Leaving the Door Open for Technical and Social Expansion.....	16
2.6.1 Expand as Local Confidence Grows.....	18
2.6.2 Social Change More Difficult than Technical Innovation...	19
2.6.3 The Slow Pace of Change.....	19
2.7 Human Resources Development.....	20
2.8 Working with Government Agencies.....	21
<b>PART II: STEPS IN PROJECT DEVELOPMENT</b>	
3. COLLECTING INFORMATION.....	25
3.1 General Background Information.....	25
3.2 Establishing Site Selection Criteria and Guidelines.....	27
3.3 Village Profile Information.....	32
3.3.1 Basic Village Data.....	32
3.3.2 Perceived Needs of the Community.....	33
3.3.3 Water Uses and Sanitation Practices.....	34
3.3.4 Technical Data on Available Water Sources and Their Uses.....	35

Chapter	Page
3.3.5	Financial Data..... 35
3.3.6	Resources for Operations, Maintenance, and Training..... 36
3.3.7	Village Health Status..... 36
3.4	Other Studies and Surveys..... 36
3.4.1	Technical Surveys..... 36
3.4.2	Water Usage and Sanitation Studies..... 37
3.4.3	Household Surveys..... 37
3.5	Survey Methods..... 37
3.5.1	Sources of Information..... 37
3.5.2	Sampling Techniques..... 38
3.5.3	Interview Methods..... 39
4.	DETERMINING RESOURCE NEEDS..... 41
4.1	Human Resources..... 41
4.2	Procurement of Human Resources..... 45
4.3	Material Resources..... 47
5.	DESIGNING THE PROJECT..... 49
5.1	Maximizing Health Benefits..... 49
5.1.1	The Quantity of Water..... 49
5.1.2	The Quality of Water..... 51
5.1.3	Secondary Contamination of Water..... 53
5.1.4	Complementary Activities in Sanitation and User Education..... 54
5.2	Optimizing the Participation of Communities in Project Design, Implementation, and Evaluation..... 55
5.2.1	First Principle--Allow Enough Time to Promote Participation..... 55
5.2.2	Second Principle--Participation Must Involve Actual Decision-Making..... 59
5.2.3	Third Principle--Train All Project Staff to Support Community Participation..... 59
5.2.4	Fourth Principle--Take Steps to Assure Sustained Partici- pation after the Project is Complete..... 60
5.3	Determining the Proper Level of Community Financing of Construc- tion, Operations, and Maintenance..... 61
5.3.1	Capital Costs..... 61
5.3.2	Recurrent Costs..... 62
5.3.3	Revolving Funds..... 63
5.4	Designing Educational Efforts in Support of Community Participa- tion..... 63
5.5	Minimizing Maintenance Requirements..... 64
5.6	Designing a Sanitation Program..... 65
5.6.1	Latrine Usage..... 65
5.6.2	Personal Hygiene..... 68
5.6.3	Food Hygiene..... 68
5.6.4	House Protection..... 69

Chapter	Page
6. SELECTING THE MOST APPROPRIATE TECHNOLOGY.....	71
6.1 Factors Influencing Technology Choice.....	71
6.1.1 Physical Characteristics.....	71
6.1.2 Human Settlement Patterns.....	72
6.1.3 Traditional Practices and Beliefs.....	72
6.1.4 Past and Current Organizational Experience.....	73
6.1.5 National Government Policies.....	73
6.1.6 Current Economic Conditions.....	74
6.1.7 Access to Technical Expertise and Project Materials.....	74
6.1.8 Emergency Situations.....	74
6.2 Methods for Selecting a Technical Approach.....	75
6.3 Water Supply Technology Options.....	76
6.3.1 Gravity-Flow Systems.....	77
6.3.2 Capped Springs.....	77
6.3.3 Rainwater Catchment.....	81
6.3.4 Machine-Drilled Wells.....	82
6.3.5 Hand-Dug Wells.....	83
6.3.6 Handpumps.....	85
6.3.7 Animal Traction Pumps.....	86
6.3.8 Wind-Powered Pumps.....	87
6.3.9 Solar-Powered Pumps.....	88
6.3.10 Hydraulic Rams.....	90
6.3.11 Diesel- and Gasoline-Powered Pumps.....	90
6.4 Sanitation Technology Options.....	92
7. PREPARING THE IMPLEMENTATION PLAN AND SCHEDULE.....	101
7.1 Start-Up Activities.....	101
7.1.1 Agreements.....	101
7.1.2 Budget Approvals.....	101
7.1.3 Release of Funds.....	102
7.1.4 Staff Recruitment.....	102
7.1.5 Office and Warehouse Facilities.....	102
7.1.6 Administrative Systems.....	102
7.1.7 Surveys and Data Collection.....	103
7.1.8 Site Selection.....	103
7.1.9 Vehicles.....	103
7.1.10 Fuel.....	103
7.1.11 Equipment Procurement.....	104
7.1.12 Materials Procurement.....	104
7.2 Implementation Activities.....	104
7.2.1 Design Preparation.....	104
7.2.2 Land Title.....	105
7.2.3 Water Quality Testing.....	105
7.2.4 Committee Formation.....	105
7.2.5 Community Participation.....	105
7.2.6 Materials Storage.....	106
7.2.7 Construction Activities.....	106
7.2.8 Training.....	106
7.2.9 Health and Sanitation Activities.....	106
7.2.10 Evaluation.....	107

Chapter	Page
8. PLANNING TO ASSURE LONG-TERM SYSTEM RELIABILITY.....	109
8.1 The Design Must Be Appropriate.....	109
8.2 A Local Operation and Maintenance Organization Must Be Formed...	110
8.3 A Regional or National Support System Must Be in Place.....	111
8.4 The Local Population Must Learn How to Use the System Correctly.....	112
8.5 System Operators and Maintenance Staff Must Be Trained.....	112
8.5.1 Training Requirements for Gravity-Feed Water Supply Systems.....	114
8.5.2 Training Requirements for Handpump-Dependent Water Supply Systems.....	115
8.5.3 Training Requirements for Simple Waste Disposal Systems..	115
8.6 Adequate Transportation for Technicians, Materials, and Spare Parts Must Be Available.....	117
8.7 Long-Term Financing of Operations and Maintenance Must Be Assured.....	117
8.8 Spare Parts Must Be Supplied.....	119
8.8.1 Determining What Spare Parts Are Needed.....	119
8.8.2 Specifying Quantities.....	119
8.8.3 Location of Spare Parts Inventory.....	121
8.8.4 Transportation of Spare Parts.....	121
8.9 The System Must Be Perceived as Vitally Important by Local Users.....	121
8.10 Users Should Feel Responsible for Keeping the System in Working Order.....	121
9. EVALUATION OF WATER SUPPLY AND SANITATION PROJECTS.....	123
9.1 An Evaluation Framework.....	123
9.2 Level 1 or Functional Outcomes of Water Supply and Sanitation Projects.....	125
9.3 Performance Outcomes.....	125
9.4 Impact Evaluations.....	126
9.5 Additional Considerations.....	127
 <b>APPENDICES</b>	
I. Sample Site Selection Criteria.....	129
II. Sample Village Questionnaire.....	133
III. KAP Survey.....	139
 <b>ANNOTATED BIBLIOGRAPHY.....</b>	 149



**TABLES**

**Page**

1. Descriptive Comparison of Sanitation Technologies.....	94
2. Critical Information Needed for Selection and Design of Sanitation Systems.....	95
3. Recommended Spares for Each India Mark II Deep Well Handpump for Two Years' Operation.....	120

**FIGURES**

1. Information Collection, Project Design, Monitoring, and Evaluation...	26
2. Sample Staffing Patterns.....	42
3. Technical Skills Availability Check-Off List.....	44
4. Impact Evaluation Model.....	124



## ABBREVIATIONS

FC	fecal coliforms
FY	Fiscal Year
Hp	Horsepower
ITDG	Intermediate Technology Development Group
KAP Survey	Knowledge, Attitudes, and Practices Survey
MYP	Multi-year plan (CARE)
P.L. 480 funds	Public Law 480 funds
PAT	Project activity target
PIE Report	Project Implementation and Evaluation Report (CARE Monitoring Document)
PV	Photovoltaic
PVC	Type of plastic pipe
ROEC	Reed Odorless Earth Closet
UNDP	United Nations Development Program
UNEP	United Nations Environmental Program
UNHCR	U.N. High Commissioner on Refugees
UNICEF	United Nations Children's Fund
USAID	United States Agency for International Development
USDA	United States Department of Agriculture
VIP	Ventilated improved pit latrine
WASH	Water and Sanitation for Health
WHO	World Health Organization
WSS	Water supply and sanitation



Part I  
FUNDAMENTALS



## Chapter 1

### THE PURPOSE AND SCOPE OF THESE GUIDELINES

This introduction reviews CARE's water supply and sanitation activities since the organization's founding. It then presents, in summary form, the purpose and scope of this guideline document<sup>1</sup>. The introduction concludes with suggestions about how the guidelines can be used in three key sector activities: new projects, existing projects, and personnel training.

#### 1.1 An Overview of CARE's Community Water Supply and Sanitation Activities

Water supply has figured as a significant area of development assistance for CARE almost from the agency's inception in 1946. The pace of CARE water supply operations has picked up steadily since those early efforts. From 1967 on, CARE's water programming expanded rapidly. Over the next nine years, some 650 water distribution systems, 1,500 wells, and 3,700 pumps were installed in 28 countries. By 1976, dollar allocations for water supply came second only to those for food distribution. Most of these water projects were sited in rural areas.

#### 1.2 Water Supply and Sanitation

By the early 1980s, the water sector had broadened in CARE programming to incorporate a number of sanitation projects. Together, water supply and sanitation activities accounted for fully one-fifth of CARE's overall non-emergency, non-food supported assistance program. Basic rural water supply activities continued to account for a large percent in overall expenditures; but sewage system and latrine projects, as well as a variety of health-related and water/sanitation system maintenance training activities, had been added to the sector portfolio. In addition, two projects provided for joint development of potable water supply and irrigation systems.

In 1982, CARE spent some \$11 million on 39 separate projects in water supply, sanitation, and irrigation in 20 countries. Training continued to be an important focus. Within the sector, two-thirds of the projects focused on improving the health status of user populations. Roughly a quarter fit within the integrated rural development category. Only five percent are categorized as irrigation activities. About three-quarters of those projects include both system maintenance and health-hygiene training components. Only a quarter, however, incorporate sanitation or agricultural components.

Of the 39 projects on line in 1982, 19 were sited in Latin America, 11 in Africa, and nine in Asia.

<sup>1</sup>~~This document~~ draws very heavily on Kevin Henry's 1982 CARE Program Department document, "Community Water Supply--Guidelines for Future CARE Programming."

From FY 1983 to FY 1985, CARE annual programming for water supply and sanitation activities hovered around the \$11 million mark. Water and sanitation has continued to be an important sub-area within CARE's primary health care sector. In FY 1986, fully one-third of the 66 projects in that sector focused on water supply and sanitation. These projects, again with a total funding of nearly \$11 million, were distributed among 18 countries, nine in Latin America, seven in Africa, and two in Asia. The total target population over the life of these projects is expected to exceed 1,250,000 people.

Clearly, water supply and sanitation have become a permanent and substantial part of CARE's development activities. This fact justifies production of this volume of guidelines.

### 1.3 The Purpose of the Guidelines

These guidelines grow out of CARE's long field experience in the water supply and sanitation sector. They will facilitate better programming in the sector by making available to CARE personnel a great deal of relevant technical, social, and project management information assembled here for the first time in one place. They draw together some lessons of the organization's two decades of experience in the sector and make them available in concise form to interested users. Where relevant, the guidelines also reflect experiences of other voluntary agencies and international donors active in the water and sanitation sector.

The guidelines provide a clear summary of CARE sector policies and their practical implications for particular types of projects. Because they make standard information readily available to those who need it and can use it, they should reduce project design and control costs. By relying on the guidelines, project designers, implementers, and evaluators can carry out their tasks more effectively.

CARE personnel and consultants in all phases of water and sanitation programming can use this document. Primary users will include headquarters sector staff, field mission directors, and specialist personnel involved in designing, implementing, and evaluating projects in the sector and outside consultants who participate in project activities on a short-term basis. Other private voluntary organizations, bi-lateral and multi-lateral donors, and agencies involved in rural water and sanitation may also find these guidelines useful.

The guidelines are relatively comprehensive in scope:

- They emphasize an approach which integrates social with technical aspects in planning, implementing, monitoring, and evaluating sector projects and outlines appropriate linkages between project components in different types of water and sanitation sector activities.



- They stress the importance of proper sequencing in project activities, especially in promoting user participation during all project phases. Here especially, careful attention to the series of steps detailed in the guidelines will allow designers and implementers to avoid a number of errors or omissions which have plagued some CARE sector projects in the past.
- They provide technical data about existing water supply and sanitation systems to enable field personnel and users to make reasoned decisions on technical issues in selecting options.
- Finally, they offer suggestions about the kinds of follow-on activities which can result from water projects.

Certain limitations of the guidelines, in scope and depth, must be noted. In the first place, they do not address refugee problems in the water and sanitation sector. They are meant to provide guidance concerning projects in stable, existing communities. The quasi-emergency situations of refugees present special difficulties which lie beyond the scope of this document.

The guidelines are not intended as a manual on construction techniques. They highlight major technical issues which may influence the choice of one system or approach over others. But other sources provide much fuller information on the practical details of building those systems. Some useful titles are given throughout this document.

#### 1.4 Guideline Applications

The guidelines should be helpful in three specific areas: new projects, on-going projects, and training staff.

##### 1.4.1 New Projects

The guidelines list the steps involved in designing a project from pre-conditions for project design to the project design process itself. Design pre-conditions include needs assessment, macro-site selection, analysis of resource requirements, potential constraints, and technical options.

The guidelines also list the steps necessary to promote community participation in system design and operation. If followed carefully, they will help CARE personnel focus on opportunities to greatly increase chances of community support for the project. At the same time, they can keep designers and implementers from selecting inappropriate physical systems.

The guidelines specify the sort of information necessary to judge whether a proposed system can succeed in a given environment. They lay the groundwork

for data collection after the system has been installed and is operating. They suggest the types and quality of information necessary to monitor water or sanitation systems over time.

The information provided in this document is designed to help field staff distinguish between problems--both technical and social--which they can handle with their own resources and those for which they would be best advised to seek assistance, either from headquarters or from technical consultants.

#### 1.4.2 On-going Projects

Once project implementation begins, a host of problems have to be dealt with on a daily basis. Many will be handled by members of the local project committee, if they have been adequately prepared for their task and have the requisite authority. Other technical or social problems will require either support from field staff or their direct intervention. The guidelines illustrate appropriate ways of enabling local people to deal with problems.

The guidelines also supply detailed data about technical options not readily available from other sources to field staff working in isolated areas. In the event that project personnel decide to introduce a monitoring component or upgrade an existing one, the guidelines contain information about monitoring techniques upon which field staff can draw in making decisions in this area.

#### 1.4.3 Training Staff

The guidelines not only constitute a basic reference volume for CARE field personnel but also can serve as a major source of training materials for in-service workshops.

They identify the basic elements which should be introduced in any workshop designed to train new staff, discuss the broad policy issues involved in implementing water supply and sanitation projects, and provide important background for analyzing proposals for new sector projects or for modifications in on-going projects.

## Chapter 2

### BROAD POLICY ISSUES IN PLANNING AND IMPLEMENTING WATER SUPPLY AND SANITATION PROGRAMS

A series of broad policy issues require discussion before more specific aspects of water and sanitation project planning and implementation can be examined. Each of the following issues is discussed in this chapter:

- participation
- health and economic issues
- sanitation considerations
- health education
- systems operations, management, and financing
- technical options and add-on capability
- human resources development
- relationships with government agencies.

#### 2.1 Who Should Decide on the Purpose and Approach of a Project?

Rural water and sanitation projects, like most other development activities, raise the fundamental question: Who should decide on the purpose(s) and approach? Possible answers include (1) the national government; (2) intermediate level governments (regional, state, district); (3) the donor agencies involved in financing physical inputs and technical assistance; (4) the technicians, either national or expatriate, who design the project; and finally, (5) the users whom the project is designed to serve. In practice, project designs usually reflect input--and pressure--from more than one of these groups. But whose interests should take precedence in the design process?

##### 2.1.1 Political Actors and Technical Experts Usually Dominate

National government officials often claim overall responsibility for national development and for the welfare of the country's population. Thus, they assert their authority to allocate resources and decide on development options. While current governments in many countries are less prone now than two decades ago to try to regulate development projects down to the last detail; nonetheless, decisions taken at the national level about the "most appropriate" type of project may exclude certain options which other actors would like to consider. For instance, possible surface water treatment should be preferred to boreholes or water projects should promote health above everything else.

Conflicts between planning ministries and line ministries (health, agriculture, rural development, and so on) or between the national level and

subordinate levels of a given ministry often produce constraints on design. They can be overturned or circumvented, but the costs of doing so frequently exceed the probable benefits. As a result, certain projects, otherwise promising, remain unattractive.

UNREALISTIC CONSTRUCTION STANDARDS  
FRUSTRATE PUBLIC HEALTH PROJECT  
IMPLEMENTATION

A Togo water supply project hesitated to promote latrine construction because the Ministry of Health prescribed a fully-lined brick model costing about \$400. In the project plan, only this model had been suggested. According to original calculations, cost considerations would limit construction to one per village or per school at most.

Another source of difficulty may arise because of political pressures to expand a project rapidly in its initial stages to assure political support and protection for the activity. If enough areas are affected by the project, they may represent a "winning coalition" in its favor. While the support may be both useful and appreciated, it has a clear cost: dramatic expansion of a project before a technology is thoroughly adapted to local circumstances or before the logistics of field support are firmly in place may convert a small but promising activity into a large but ineffective one.

Intermediate level (regional, state, district) governments, if they have the authority to do so, may act in much the same manner as the national governments. They may select options for water supply and sanitation project technologies or goals which narrow the range of choice for other actors in the process.

Donors and private voluntary organizations have long been aware of the relationship between water supply and sanitation and health concerns. As a result, the water and sanitation projects they design have had the primary goal of producing health benefits.

Technicians have played a key role in designing many water projects. They have naturally been willing to provide their interpretations of the purposes and goals of sector projects. Armed as they are with technical qualifications and often considerable field experience, they expect to play a large part in water supply system planning. Sometimes, acting through national water agencies or through large-scale, donor-financed development operations, they have

influenced policy decisions extensively in the water and sanitation sector. Perhaps even more important, they have often had the last say at the individual project level about technologies to be employed, methods of system construction, financing and maintenance, and the content of the associated health and sanitation training programs.

Typically, most of these political actors and technical experts can produce good arguments to buttress their decisions or recommendations about sector activities. But, because of their greater authority or funding capability or other sources of influence, they have often been able, alone or in combination, to dominate the design and implementation process. In consequence, user input--the ideas and experiences of local people--has often been neglected.

### 2.1.2 Local Participation is Key to Project Success

Taking account of local input is bound to be costly. It requires time-consuming efforts to organize local people or to devise ways of recording their opinions. If people are to debate the pros and cons of different options, they may have to spend a good deal of time trying to understand those options technically. They may have even more difficulty trying to understand the "social" (economic, political, legal, and religious) implications of particular project types. Dialogue takes time.

Rarely does a proposed development project elicit unanimous approval from all those potentially affected by it. Location of stand pipes may be a contentious issue, as may decisions on siting wells. Reservoirs take land--often good bottom land--that someone may now be farming. Distribution pipes may interfere with existing patterns of livestock movement on the land. Certain types of systems may require investments in construction or maintenance that poorer members of a user group may be hard-pressed to provide. In short, users have to think through a multiplicity of issues. User input may therefore take time to develop and be expensive to obtain.

Furthermore, users may change their minds as they gain more experience with new systems. They may want to modify water supply systems technically, or they may want to reorganize maintenance procedures. Conflict within communities, as well as between them, is extremely common and must be expected to affect implementation of water, as well as other types of projects.

Such conflicts or changes can wreak havoc with project planning schedules, especially if deadlines are tight. Hence, planners and administrative officials often decide to "cut through all the irrelevant talk" (or avoid it altogether) by imposing their own decisions as a short-term solution. But this approach also has its costs.

INTERVILLAGE POLITICAL RIVALRY PREVENTS COMPLETION OF  
VILLAGE WATER SUPPLY PROJECT

A drinking water scheme organized in a Nepalese village during the 1970s reveals the dangers inherent in working within factionalized communities. In 1979 a government agency launched a drinking water scheme in a remote area. Two village leaders, in competition with each other for political power within the community, began wrangling over the distribution of water taps. One believed his supporters, who were villagers of high status, should be accorded more taps. The other argued in favor of improving access to drinking water for a larger proportion of the population. People in the latter group tended to be of low status.

Both leaders appealed to political figures in higher jurisdictions and to officials in government ministries. The conflict had not been resolved at the time of writing. Until some sort of agreement is reached, the financing agency will refuse to proceed with the project.

User participation is a tool to make certain types of projects work better. People active in the water supply field only noticed its partial or total absence in planning processes when they began to see serious problems with many politically-shaped, expert-designed water and sanitation projects. Expensive systems have been installed and not used. Others have been used briefly and then poorly maintained, to the point where they function at far less than programmed capacity. Still others have simply been abandoned after breakdowns, even though individuals in the user community were trained in basic maintenance procedures.

INADEQUATE ATTENTION TO USER ATTITUDES LEADS TO  
WELL PROJECT FAILURE

In central Tunisia, many old wells exist which date back to Roman times. A number of these are not in fact wells in the usual sense. Instead, they tap into underground streams. In an effort to rehabilitate them, these wells were fitted with handpumps.

The project designers, however, failed to investigate local preferences sufficiently and thus did not realize the population preferred open wells because the wide bore permitted several women to draw water at the same time. With wide bore wells, women spent less time standing in the hot sun waiting to draw water. In addition, most of the wells were sited on common lands which no particular individual owned. As a result, when the pumps broke down, no one repaired them. Worse yet, many were pulled off the wells. Some were vandalized.

Under-utilization and outright abandonment are symptomatic of inappropriate system design. If the target group--the presumptive "users"--neither use nor maintain the water or sanitation system, the designer and installer should ask why. Answers to that question vary with the local situation:

- The water supply is inconveniently located.
- The water has an unpleasant taste.
- Construction is faulty.
- Maintenance is too expensive.
- Necessary spare parts are in short supply.
- People don't know proper basic maintenance techniques or ways to get help when local knowledge fails to resolve a problem.
- Local people cannot organize themselves to operate a given system.
- People lack interest in the benefits the system provides.

These answers, though they are varied, almost always contain explanations or strong clues about how the system might have been better designed or why it should not have been built at all.

The conclusion of this discussion about who should say what and when about water projects may be simply put: project design and implementation processes should be set up to ensure that local people--users--will participate at all stages. That conclusion can be put even more strongly: users should assist in developing projects and have a veto over project designs and project implementation strategies.

Recurrent cost problems--those associated with keeping development projects operating on their own after initial funding has terminated--plague most Third World countries today. Therefore, whenever possible, most governments and donors will seek to shift the costs, not only of project construction but also of project maintenance, to users. If users are unhappy with projects, they can kill them by quietly failing to provide necessary maintenance.

## 2.2 Water Quality Versus Water Quantity and Accessibility

### 2.2.1 Health Benefits Traditionally Emphasized

Until very recently, health concerns motivated most donor-financed interventions in the water and sanitation sector. Most people assumed that more and better water meant better health. But this relationship has proven difficult to demonstrate and certainly far more complex than has often been assumed. Other factors--nutrition levels, efficacy of sanitation programs, general income levels--also significantly affect health standards. Nonetheless, the presumptive connection between health and water supply has strongly shaped the project process.

In some donor agencies--the U.S. Agency for International Development (USAID), for instance--most water project funds came from health accounts. Since other types of health projects proved more cost effective, water supply operations often suffered. In addition, the assumption that water and health were linked frequently meant that water projects were saddled with health and sanitation components without regard to user needs or preferences and with no clear notion of how to implement those components. Technicians and political actors simply wrote health and sanitation into projects. Local people had no say. Poor planning or delays meant people in many cases derived less satisfaction from sector projects than they might have otherwise. Maintenance suffered as a result.

### 2.2.2 Focusing on Benefits that Users Themselves Define

More recently, a new consensus has begun to form on the water and health issue. The consensus is that, while there is a positive relationship between water and health, users should be involved in planning and implementation and project designs should maximize health benefits. In particular, it is now assumed that:



- The developmental impact of water supply projects extends well beyond their direct health benefits; water project structure, content, and financing should reflect this fact.
- By comparison with longer-term, indirect health improvements, users often grasp more quickly and value more highly the direct economic benefits which go with provision of more water at more reliable and accessible points.
- Components to be built into water supply projects should not be pre-determined but rather defined through needs assessments and technical, economic, and political feasibility studies carried out in close collaboration with the potential users in any given situation.
- Water supply projects will often be multi-purpose, incorporating components focusing on agriculture, animal husbandry, or village industry or on primary health care, excreta disposal, health education, and hygiene.

This change in conventional wisdom about water supply projects clearly reinforces the increased emphasis on identifying user needs at the project design phase, and it also has fairly pointed implications for the relative importance of water quality versus water quantity and accessibility.

Water quality has been a priority concern in large part because donors assumed the purpose of water projects was to improve rural community health standards. In fact, recent research suggests that most users place greater importance on water quantity and accessibility than on quality. This finding may reflect the users' complete ignorance about the relationship between water quality and some disease vectors (although most rural users know certain kinds of water can "cause" certain diseases), or it may simply suggest that users value the prospect of possible reductions in disease incidence over the short or long haul less than they do the opportunity to have adequate quantities of water defined as usable by local standards. That some users take this position by no means guarantees it is the wisest one or, over the long run, the most productive way to approach water supply problems. But it is important to take it into account in thinking about the water sector and the design of water projects.

Emphasis on quantity over quality in no way excludes concern with health benefits, particularly where water-washed diseases are concerned. Without adequate supplies of water, personal hygiene is difficult to maintain. Moreover, increased water quantities may enable local people to pursue new economic opportunities, giving rise to three distinct advantages: (1) over the long haul, the burden of system maintenance may become easier to bear because personal incomes rise; (2) add-on components which produce more health benefits can be undertaken when users feel the need to do so; and (3) the very fact of making decisions about such important matters may increase users' confidence in their ability to run a water supply system to their satisfaction, that is, in a way that leaves them better off as they see it.

Short term  
- not seeing health benefits  
- exploit of water resources

#### USEFUL REFERENCES ON WATER QUALITY AND QUANTITY

Feachem, McGarry, and Mara, eds. Water, Wastes and Health in Hot Climates. (See "The Quality-Quantity Dilemma," p. 85.)

Complete bibliographic information for these items and all other items that are listed in these boxes in the text) may be found in the Annotated Bibliography.

### 2.3 Sanitation Considerations

Sanitation involves more than mere physical structures for excreta disposal. It concerns a whole range of actions taken to protect and improve the environment in which people live. Water supply in adequate quantities is essential to most sanitation activities. Even handwashing requires a minimum amount of water per person per day. Therefore, one should not begin promoting most sanitation activities until at least 15 to 20 liters of water per person per day are available to a population. On the other hand, where water is abundant, arranging adequate drainage around water points and, indeed, throughout entire local communities may be a priority sanitation activity.

Sanitation falls most often under the aegis of the Ministry of Health rather than under the water supply agency with which CARE is cooperating in a water supply project. Of course, if CARE is already cooperating with the Ministry of Health in another project (nutrition or primary health care), collaboration may be easier. In any case, one will encounter the following problems inherent to sanitation services in most countries: shortages of trained personnel, few vehicles, short fuel allowances, low salaries, and a multiplicity of health work duties competing with community sanitation.

Well trained, highly motivated sanitarians equipped with transport can be of invaluable assistance in planning and implementing water supply programs and training personnel. Assuming such personnel are available (at least in supervisory positions), they can help project personnel deal with issues such as the timing of sanitation inputs in relation to improvements in water supply and promoting community participation.

In general, where water is in insufficient supply, sanitation efforts other than relocation of excreta disposal should be delayed until adequate water is available. In well-watered areas, however, an argument can be made for emphasizing sanitation in a program before water supplies are put in. Such was the case in the early stages of the Imo State Water and Sanitation Project financed in Nigeria by UNICEF. Whether sanitation improvements are implemented before or after water supply, a well organized approach will be required to overcome the inherent difficulties encountered.

If sanitation programs are to succeed, they cannot be imposed on communities but should be introduced as solutions to problems which locals identify. These issues should also be raised during the community participation process. Thus, as diarrhea or intestinal parasites are identified as problems, latrines, hand-washing, and food hygiene can be suggested as parts of appropriate solutions. In this way, the implementation of sanitation measures will become an integral part of a community-initiated plan, complete with objectives and community-initiated means for reaching them. In Malawi, for example, latrines, showers, washing slabs, and dish drying racks have been introduced in entire villages by means of a decision made and enforced by the village health committee.

#### 2.4 Health Education--A Problem of Definition

Health education is considered an important aspect of rural water supply and sanitation projects. Many, however, view health education as the mere transmission of educational messages rather than the more complicated and time-consuming effort of modifying human behavior. For this reason, many people now advocate changing the name of these activities from "health education" to "program communication." Granting that it is difficult to interpret just what health education is, renaming it "program communication" leaves one with the distinct impression that transmission of messages is still the central focus.

Others have defined health education as "social marketing." The latter, now in vogue among development agencies, borrows techniques from commercial marketing but stresses two-way communication at the outset to shape message content and format. However, "social marketing" sounds more like selling products than fostering development.

In water supply and sanitation projects, health education is a combination of activities undertaken to achieve voluntary behavioral change with respect to the use and benefits of water and sanitation facilities.

#### 2.5 Anticipating Problems in Systems Operation, Management, and Financing

Moribund installations help no one. They reduce the flow of benefits potentially available to those who would use the water or sanitation system. They represent a serious waste of funds donated by CARE supporters and by all governments and private voluntary organizations which collaborate with CARE on rural water supply and sanitation projects. They retard development. If there is a high probability that a project will not be correctly executed, it is far better not to start it. If it becomes apparent, during planning or implementation stages, that a project will likely fail, it is usually better to terminate it than to press on in the face of probable system break-down.

In those situations where, despite severe problems, some local people still show interest in a proposed water or sanitation project, it may be appropriate

to continue a general health education program with an eye to building local support of the project over the long run.

### 2.5.1 Organizing Users to Deal with Maintenance Problems

Urban water systems tend to be both capital intensive and sufficiently large in scale to justify professional management. Professional managers may find it somewhat easier than unpaid community people to organize and operate user fee systems, which assure that water consumers support some or all of the costs of operating the system. By contrast, rural water supply and sanitation projects tend to be more complex socially than they are technically. Most rural water supply and sanitation systems depend for their success--defined as continued accessible provision of water at accessible sites and at acceptable levels of supply, cost, and quality over long periods of time--to a very great extent on user participation in maintenance.

Typical rural water systems, such as covered wells, capped springs, roof cisterns, and gravity-flow systems, may not be technically sophisticated; but they do have weak points. If problems are not rectified rapidly, systems can break down and stay down for long periods of time. If users are dissatisfied because of frequent interruptions in water supply, they will not often provide the financing needed. As a result, water supply and related health and sanitation benefits may not be attained, and capital and social investments will be lost.

The experience of CARE and others in rural water supply projects suggests that maintenance occurs only when users value the system, are organized to deal with maintenance problems, and either have the technical knowledge to repair breakdowns themselves or know how to get help from outsiders at costs which users are prepared to pay.

Research shows that the continued support of users depends upon whether or not they participated fully in all phases of project development and execution. Users bring to project design issues a very specialized, indispensable knowledge: familiarity with local conditions, social as well as physical. They are the best judges, in the end, of the probable value to them of the water supply or sanitation system intended for them. If a system is to run properly, users must support it, agree to the terms and conditions upon which it is made available to them, and accept the costs involved in maintaining it.

### 2.5.2 Minimize Reliance on Resources Outside the Community

Most things are harder to do in developing countries. This truism, banal though it may be, carries a crucial implication for water supply projects. Systems whose long-term operations depend upon technicians, politicians, administrators, and financial sources located outside the user community will be fragile systems. They will also be expensive to operate. Obviously, repairs

INADEQUATE KNOWLEDGE OF WELL CONSTRUCTION TECHNIQUES  
RAISES COSTS AND LOWERS WATER QUALITY

In 1972 Kaunguni village in Kenya launched a well project on a selfhelp basis. Volunteers dug down 15 feet to the water table. The well was surrounded by an enclosure to keep animals from contaminating the source. Ten years later a tank with an attached watering trough was added to facilitate stock watering. A villager was hired to maintain water levels in the tank, organize stock watering, and collect user fees from non-residents. Villagers clearly found the scheme attractive and persisted with it for more than a decade, despite serious difficulties.

However, there was a problem with the well. Its wall collapsed repeatedly because nobody involved with management during the first decade of operation was familiar enough with well building techniques to organize construction of a retaining wall. In order to use the well, villagers had to contribute labor and other resources to re-excavate it from time to time. In consequence, they could not muster the materials necessary to cover the source and so continued to consume contaminated water for another 10 years. Late in 1982, however, a community health worker familiar with simple construction techniques advised them on reliable ways to reinforce and enclose the well, which the Kaunguni villagers then did.

involve out-of-pocket costs to buy replacement parts and perhaps construction materials not locally available. But other costs which users may have to bear must be calculated as well. If help is necessary from a technician outside the community, somebody has to spend the time and energy to do that. If help is needed urgently, someone's work schedule is going to be disrupted. If communications are poor, it may be costly if the trip cannot wait until the next regular market visit.

If disputes about the water system arise among users and cannot be settled at the local level, help from outsiders will be necessary. An administrator or a politician in an overriding jurisdiction might have to be brought in. Such people are busy, and they know the value of the services they provide. Those services will not generally be made available free of charge. No money may change hands, but expensive political debts may be incurred which will have to be repaid some day, perhaps at a time when local people are very hard pressed.

It is, therefore, terribly important at the planning stage to work through and design out as many potential sources of conflict as possible. It is equally important to provide for local dispute resolution procedures insofar as possible. At the planning stage, local people can provide invaluable information about possible problems and reliable resolution procedures.

Failure to provide adequately for these contingencies probably goes a long way to explain why many systems are never repaired when they break down. People may value the systems; but the perceived costs of repairing breakdowns, both technical and social, may be so high that users simply decide that water is not worth the effort.

## 2.6 Leaving the Door Open for Technical and Social Expansion

In general, the simplest technical option which will suffice should be adopted. Furthermore, CARE prefers to focus its efforts on communities which are relatively impoverished and initially lack water system management skills as opposed to those capable of financing and running technically-complex water supply or sanitation systems.

CARE has had great success with projects which start simply but provide for easy technical and social expansion. As a community grows, as its resource base strengthens, and as its experience with management of a water supply or sanitation system increases, local interest in developing a system further is likely to be great. It is crucial to build into the initial project design, whenever possible, the capability for add-ons.

Following are some examples of CARE projects that provide for expansion:

1. CARE water programming in Bolivia was evaluated in mid-1985. The evaluation report recommends among other things that all future village water projects, which to date have incorporated house connections only, be designed to provide for the option of public taps as well. Whether or not this service is provided immediately, the option will exist. Thus, water will be made available eventually to those who cannot afford the costs of an individual hook-up. A project initiated during the 1986 budget year should be rewritten to incorporate this additional element of flexibility.
2. The gravity-flow water supply system installed by CARE on the Sierra Leone peninsula was evaluated in July 1985 by a WASH team. The team recommended that home connections be reinstated in the project design, in addition to the public taps which have already been installed, to provide a further increment of service for those willing and able to pay for it. The CARE Sierra Leone staff is currently reassessing this possibility.

FAILURE TO RESPECT INTER-VILLAGE AGREEMENT  
STALEMATES PROJECT

To provide water for Birkot, the major town of a petty kingdom in Nepal, a rural development project agreed to finance the installation of a system. Local leaders and the National Assembly member decided that water would be taken from a spring located eight kilometers away in Gandruk, a neighboring panchayat, or local government unit. At first, Gandruk panchayat people resisted because they used some of the spring flow to irrigate their fields. But eventually they agreed to let the water be used on the condition that their panchayat head lay the cornerstone. This act would establish their jurisdiction's claim to the spring water.

The political leader who organized the activity was the National Assembly member for Birkot. In his eagerness to garner political support, he failed to honor the commitment made to the neighboring panchayat and launched construction by himself laying the cornerstone. The neighbors allowed construction to go forward for some time before they began to disrupt it by the simple expedient of cutting the pipe. The Birkot people persisted with construction; and the neighbors, with destruction. Two years after the starting of the project, the dispute continued.

Such conflicts or changes can wreak havoc with project planning schedules, especially if deadlines are tight. Hence, planners and administrative officials often decide to "cut through all the irrelevant talk" (or avoid it altogether) by imposing

In the meantime, the National Assembly member lost his re-election campaign and then his attempt to win the office of Birkot panchayat leader. The new panchayat head re-negotiated the water supply agreement with the Gandruk people. The latter agreed to allocate half the water to Birkot. The design of the project was revised and a new budget approved by the district assembly, but Birkot supporters of the project could not finish it: those who supported the old National Assembly member would not help and even refused to turn over tools to those willing to volunteer labor.

3. CARE Indonesia water supply projects began in the late 1970s as public tap systems but with no storage capacity at the outlets. A 1983 evaluation revealed that in some 20 percent of these projects it would be technically feasible to add on storage capacity so that nighttime flow, during periods of minimum demand, could be stored to meet periods of peak demand during daylight hours. In several cases, this additional system capacity is now actively under consideration.
4. Since the early 1980s, CARE water projects in Haiti have been designed so that storage add-ons will be technically easy to construct.

Many of the simplest improvements in water supply, e.g., upgrading open wells, can be designed to accommodate additional improvements.

5. CARE Kenya has initiated a program, with village support, of equipping traditional hand-dug, open wells with cement rims and pads. At present, enclosing these wells and equipping them with handpumps make little practical sense for two reasons. First, village populations have not yet grasped the public health reasons for protecting their water sources. Second, little mechanical expertise is available in these communities at present. Nonetheless, the well rims and pads will be designed for easy incorporation of covers and handpumps at a later date in the event local people express an interest and a willingness to share the costs of making such an investment.

#### 2.6.1 Expand as Local Confidence Grows

If the original system focuses on increasing water quantity, it may subsequently be possible to envisage technical installations which upgrade water quality, either system-wide or for particular uses. These modifications might include: potable water for humans and animals and unpolluted water for domestic wash water or possibly for fish farms or other types of production activities where a minimal grade of water quality is indispensable.

If experience with the system demonstrates it to be a reliable source of water, even during drought periods, some users may be willing to risk investment capital on small, water-dependent projects, such as truck gardens.

Other examples of incremental improvement possibilities include converting a traditional to a cased but still open well, which could subsequently be covered and fitted with pumps. When gravity flow systems are installed, enough flow should be captured so the system can be upgraded later by introducing house connections, without cutting service levels at public fountains. Once a gravity-flow system is installed, reservoirs can be added when necessary to store water at night and during low demand periods to provide ample water during peak demand periods. Yet another possibility involves improving water accessibility during a first stage and then gradually improving quality by various treatments at later stages.



If projects at the local level prove rewarding, and if additional increments of water can be supplied from existing sources, new works may be financed, which will open up each opportunity, through local taxation or cooperative cost-sharing procedures.

#### 2.6.2 Social Change More Difficult than Technical Innovation

Water system expansion, however, must not be conceived in technical terms only; there are social aspects to expansion too. Infiltration perimeters offer a classic illustration of this point. A well may be installed, properly protected from on-site pollution, and fitted with an adequate wastewater evacuation system. But water quality may remain sub-optimal for human consumption. This may happen because the infiltration catchment uphill from the well site is not properly managed. If animals are allowed to graze there, they will increase the potential pollution load by defecating and urinating. If on-site soils do not permit adequate filtration, well water quality will suffer. Well water quantity may also suffer from inappropriate exploitation of the vegetation on the well catchment area. Over-grazing or over-cutting can start a process of environmental degradation which ends with increased runoff, reduced infiltration, and a reduction in the quantity of water, to say nothing of water quality.

Both these problems are quite common in many parts of the Third World. They can quickly frustrate water supply programs, especially those focused on improving water quality for health reasons. A technical solution is known and requires practically no special expertise: controlling grazing and cutting on the watershed will remedy the problem. However, what is simple technically is often not so simple socially.

Controlling exploitation of resources on a land area is accomplished through use regulations. However, many local user groups may lack the authority and power to make and enforce rules which prevent people from using resources as they have in the past. National legislation may prohibit local user groups from passing laws to restrict cutting and grazing, and local tax systems may be prohibitive. Rather than risk a confrontation with officials by trying to exercise local powers that may not be clearly authorized, users may simply give up the idea of trying to control watershed activity and with it the potential benefits which they might reap from improved water quality or creation of a more reliable source. Another constraint on such activities might be the existence of local splits within the community or the active user group.

#### 2.6.3 The Slow Pace of Change

These illustrations suggest that it may take a good deal of time for local communities of users to develop the skills, the experience, and the history of cooperative endeavor necessary to justify further investments in upgrading water supply and sanitation systems. They may have to start at very low levels

of coordination. Agreeing to avoid conflict among members of the same user group, or to resolve disputes amicably if they arise, is an example of this kind of basic effort to coordinate activities. This approach may be especially necessary, for instance, where water supplies are limited. If the local water system management committee demonstrates its ability to successfully handle minor conflicts over water use, popular willingness to see the committee take on a larger role will likely increase.

The same may be true of awareness levels. If people find themselves better off economically because of improvements in local water supply facilities, their interest in projects to improve water quality may rise. At that point--but generally not before--training in primary health care may become highly desirable. Trying to teach people ideas they are not ready to learn is frustrating for all concerned. It also erodes the good will--institutional capital--which may exist and can be built up and built upon by organizations such as CARE through participatory planning and implementation of desired development projects.

## 2.7 Human Resources Development

Human resources development in water supply and sanitation programs is absolutely vital for successful projects. After helping plan a project, people must participate in an informed manner both in everyday operation of the system and in system maintenance. All users require a general familiarity with the system and some information about how to use it to best effect. The group charged with maintaining the system needs additional training so that it can keep water flowing in adequate amounts and quality. These points are elaborated briefly below.

All users of water supply and sanitation systems have a large role to play in maintaining them. Users must respect certain operating rules and protect the equipment from unnecessary wear and tear; those not familiar with taps and faucets must be trained to handle them properly. It may be important to urge people to exploit to the maximum extent possible improved or increased water supplies so that the community will derive the full benefit of the new system. Sanitary facilities of the simple sort generally installed through CARE projects almost always also require user maintenance if they are to function effectively and contribute to improving community health standards.

Those who are to supervise system operation and maintenance must have a thorough grounding in both. The local committee typically includes a prominent local leader, someone to manage funds, several system operators, and, if possible, a person knowledgeable about maintenance of system machinery. People must be recruited for these positions during the earliest stages of project construction, if not before. Training should stress practical, on-the-job competence in routine system operation and maintenance.

**Gravity-feed system operators must:**

- master map reading so that they can find buried system joints, valves, and other parts
- know how to test for and repair leaks and disinfect pipelines (both after repairs and as part of a routine preventive maintenance program)
- undertake routine cleaning of filters and traps
- prevent contamination of system waters through a variety of measures.

**In systems incorporating mechanical pumps, local operators should:**

- know how to check pumps and pump parts for signs of wear
- undertake routine pump maintenance
- dismantle and remount pumps--replacing parts as necessary and do major overhauls
- prevent contamination
- disinfect a water source if it becomes contaminated.

**Individuals supervising waste disposal projects (pit latrines, pour-flush privies, etc.) must:**

- know how to design simple latrines
- do simple construction jobs (for example, producing concrete latrine slabs)
- deal with structural problems in latrine systems
- disinfect latrines
- empty them, etc.

Individuals in the leadership group may also require training in need analysis procedures, communication, and group facilitation skills.

## **2.8 Working with Government Agencies**

Government agencies frequently play critical roles in the supply of rural water and sanitation services. As noted above, water systems which can be operated and maintained by their users without frequent technical or

politico-administrative assistance from outside the local community will normally provide the most reliable service. Situations may arise, however, in which such dependence on outside actions is unavoidable. CARE field personnel may be constrained, for instance, by host country government policies to work through a national rural water supply agency. Such policies are not likely to be changed over the short run, even if CARE expresses a desire to see them changed (although seeking to promote rural water policy changes over the long run may offer a reasonable and effective way to promote better water supply conditions in rural areas).

What policies should CARE adopt regarding working with government agencies? For one thing, project designs should be based as far as possible on a written protocol agreed to not only by CARE and the rural water users but also by representatives of the relevant government agencies. Such arrangements may be struck at the local level--where costs of reaching agreement may be relatively low. In some countries, higher level jurisdictions, even national ministries, may have to give approval before valid accords can be achieved. They should do so bearing in mind that water users rather than government agency personnel or CARE employees tend to suffer when agreements break down or obligations are not honored.

Support systems should be designed as far as possible to reward government agency personnel for providing required assistance in a timely manner. It is essential that civil servants receive positive reinforcement for doing their jobs correctly. If water users are positioned, by the project design, to deliver or withhold career-relevant rewards, agency personnel will likely find it useful to be responsive to water users' needs and demands.

When possible, projects should be designed so that users can seek outside assistance from more than one source. It may be possible to set up a system in which employees of one agency can act as user advocates in dealings with employees of other agencies more directly involved in water supply. For instance, public health workers may be able to encourage rural water supply or sanitation workers to deal with users' problems. Their capabilities may be far greater in this regard than those of the average water user committee member. In addition, rural water committee members or village leaders should know from the outset what channels they can pursue to get the assistance they need. What recourse do they have when they cannot get outside support? Those procedures should be clear; and those responsible at the local level for invoking them should be trained to do so, just as much as those charged with technically maintaining water supply systems should be trained so they understand thoroughly how the equipment works.

USEFUL REFERENCES ON BASIC POLICY ISSUES

McJunkin. Water and Human Health.

WHO. Maximizing Benefits to Health.

PART II  
STEPS IN PROGRAM DEVELOPMENT



## Chapter 3

### COLLECTING INFORMATION

The first step in project development is the collection of information used in formulating project goals, site selection criteria, and plans for implementation activities. Some of this information will be used as a baseline in subsequent monitoring and evaluation activities. Figure 1 illustrates the general sequence and need for information collection during the life of a project.

This section treats in detail some of the more important aspects of the information collection process and the formulation of site selection criteria. Not all types of surveys will be useful for all projects, and the amount of information required may vary depending on the type and scope of a particular project. The important point to bear in mind is that surveys can be both costly and time consuming. Therefore, the scope and size of a survey should be limited to essential requirements only.

#### 3.1 General Background Information

Certain general background information should be collected on a country-wide or regional basis. This information can be used in formulating project goals, activity targets, and site selection criteria. It can also be used to indicate generally what type of water systems are feasible and what geographical areas it would be best to concentrate on. Most background information will generally be collected from existing reports and government institutions. However, site visits to check local field conditions and verify other information sources will be required, although these do not generally involve formal surveys or data tabulation. General background information should include the following:

- health statistics for specific water related diseases (morbidity and mortality)
- general health statistics on life expectancy and infant mortality
- village health statistics on life expectancy and infant mortality, in those situations where statistics are readily available
- per capita income
- numbers and types of existing water systems (distance from users? reliability? water quantity? water quality?)
- numbers, types, and adequacy of existing sanitary facilities
- percentage of population with a potable water supply

Figure 1: Information Collection, Project Design, Monitoring and Evaluation

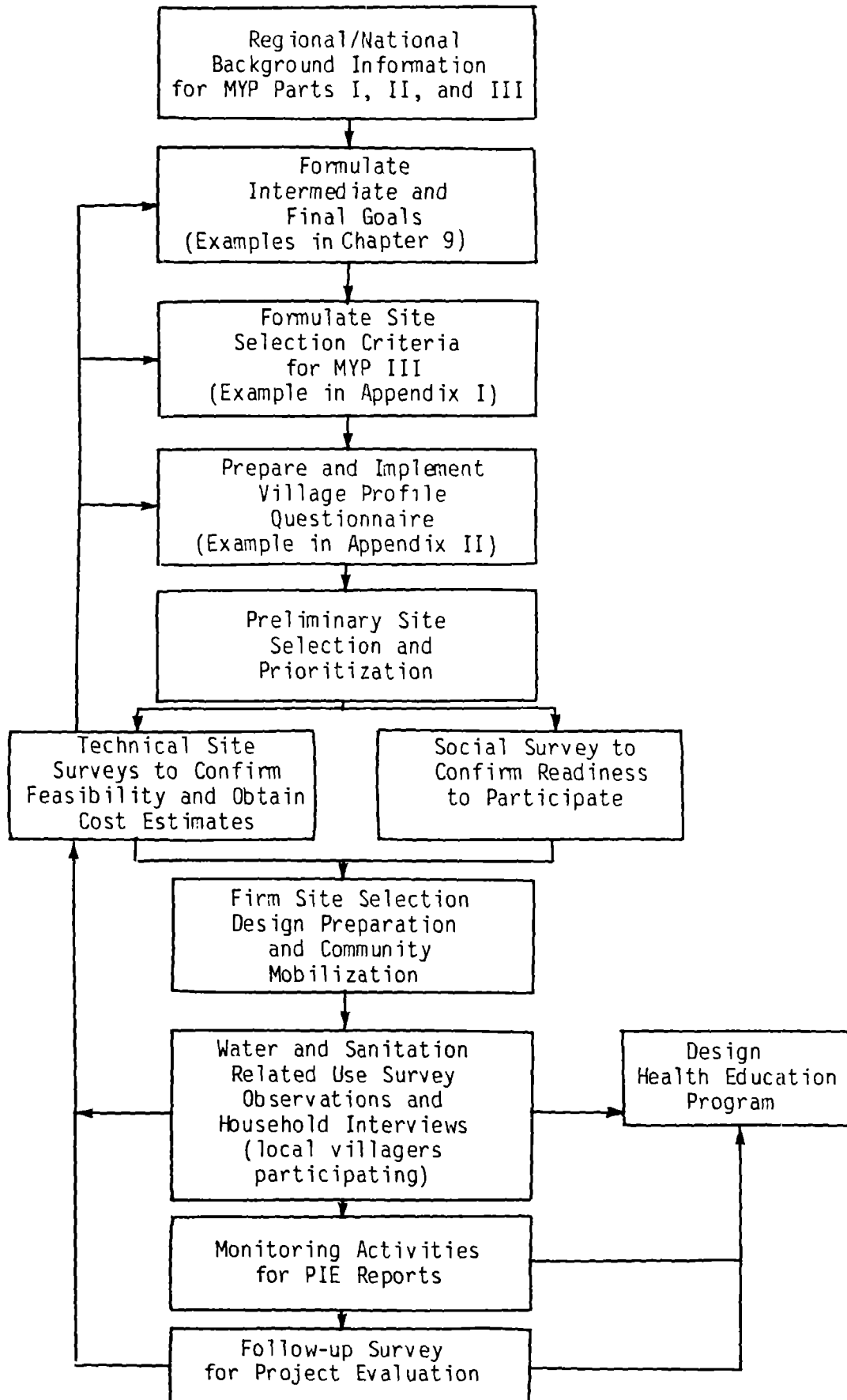



- percentage of population with adequate sanitary facilities
- government targets for water supply and sanitation
- government policy for water supply and sanitation
- average per capita water usage
- physical infrastructure (transport, services, and materials availability)
- support structures available for maintenance and repairs
- geological, hydrological, and meteorological statistics

Some of this information is generally applicable to all project sites surveyed. Information should be prepared for each region of the country or project and then items should be selected which vary by place for a more detailed survey at each site. Most of the above information is a required component of parts I and II of CARE's Multi-Year Plan (MYP).

### 3.2 Establishing Site Selection Criteria and Guidelines

Site selection is undoubtedly one of the most critical aspects of any village water supply program. Without proper site selection, it is impossible to ensure that intermediate and final goals will be achieved and that the assisted communities meet CARE's internal criteria for beneficiaries. Proper site selection, both within a region and within village communities, will also greatly reduce problems encountered during implementation.

Criteria or guidelines are essential for site selection. A criterion is some specific standard that is clearly defined and must be adhered to. For example, one criterion for site selection might be that the average per capita income of the users must be below \$100. Such a criterion may be hard to use because the necessary information about income may be either unavailable or too costly to obtain. To specify a criterion for a certain level of incidence of diarrhea at the project site is not very practical if an expensive survey has to be conducted to determine what the incidence is. Regional figures rather than local ones may be used instead. This, however, involves a risk that the site selected would have a lower incidence of the disease than the average for the region. In any case, whatever criteria are chosen must be adhered to.

Guidelines are more flexible than criteria, even though a specific figure may be used. They are also more general in nature. For example, a guideline might suggest selecting an area which has experienced an outbreak of water-associated disease. In the following discussion, the word criteria will be used throughout, although some of the suggested criteria are actually guidelines.

Site selection criteria can be based on health, economic, social, technical, geographical, or political factors. They may be highly specific or general in nature. What criteria are established will depend on local conditions and project goals. In general, there should always be criteria concerning the need for water, expectations for community participation, and technical feasibility.

The following list suggests some possible criteria:

- Potable water is unavailable, seasonally available, or available only from great distance.
- People must walk more than two kilometers to obtain potable water.
- The existing water source has more than 200 fecal coliforms per 100 ml.
- Water-associated diseases are prevalent.
- Diarrhea morbidity exceeds 20 percent or mortality exceeds one percent of the population.
- Guinea worm is endemic.
- Water supplies are unprotected. (Illustrations 1 and 2 show two unprotected sources.)
- The improvement of the existing water source or development of a new source will reduce present contamination levels by 95 percent. (For example, if the existing source has 2,000 fecal coliforms(FC)/100 ml., then the new system or source must provide water with less than 100 FC/100 ml.
- The community has demonstrated a high interest in improving its water supply and has the resources to do it.
- A water committee has been formed and a minimum of \$500 has been collected for a construction and maintenance fund.
- The community agrees to provide all unskilled labor.
- The community accepts all responsibility for operations and maintenance.
- The area has been given priority under the local government development plan.
- The area is not included in any other improved water supply scheme.



Illus. 1. Example of a dispersed population with its own watering hole. (Source: Castro/Earthscan.)

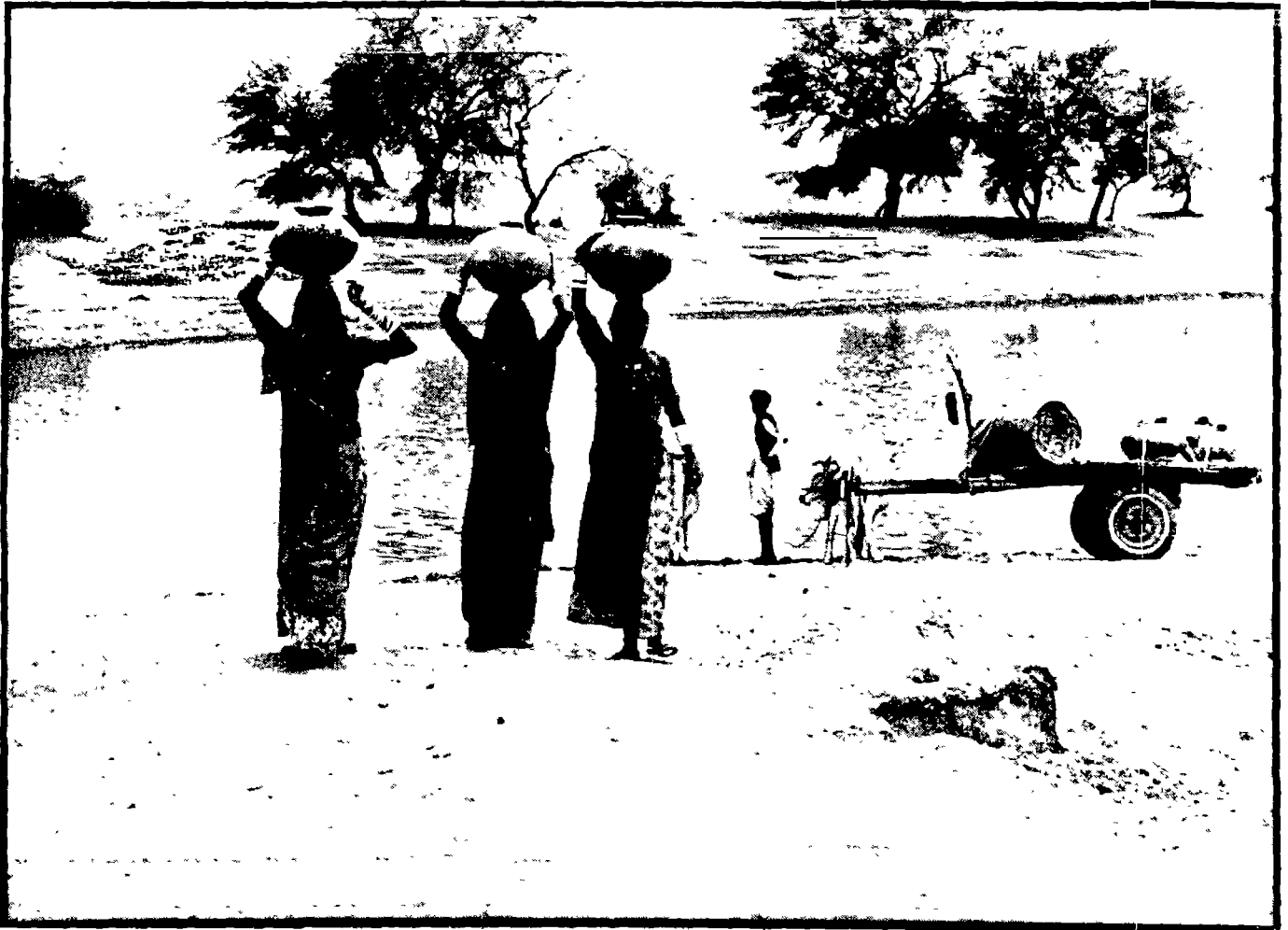

Illus. 2. Women drawing water from a river. (Source: World Health Organization.)

- A technical solution is feasible at a reasonable cost. (Amount per capita will vary by area, depending on the type of system provided and the population density.)
- The per capita cost of the water system does not exceed \$40.
- A gravity-flow water system (which will reduce maintenance costs) is feasible.
- The well location is at least 30 meters from any sanitation facility.
- The proposed water source can supply at all times a minimum of 20 to 60 liters per person per day, depending on the area and the water availability.
- The proposed water source is not already used for other purposes such as irrigation.
- A satisfactory design is ready for implementation (for programs supplying funds to a government agency or outside groups).
- The average per capita income is below \$100 to \$300 per year, depending on the area.
- Average per capita income is below \$80 for more than 50 percent of the population.
- The community considers the proposed water source acceptable.
- All people will have free access to public fountains.

The above examples are not exhaustive, and the numbers used are for purposes of illustration only. In actual practice, all of the chosen criteria may not be defined. But since they should not be weighted equally, different levels of criteria may be defined. A number of core criteria must be satisfied by all water systems. A secondary set of criteria can be defined as desirable but not essential. A third level of criteria, mainly technical, can be defined for specific types of water systems. Communities that fulfill the core criteria and technical criteria can be accepted on a first come, first served basis. If necessary, decisions to choose between two acceptable communities applying at the same time can be made on the basis of how many secondary criteria each satisfy. An alternative method is to assign a weighted value to each selected criterion and compare all potential communities to rank them in order of preference. Because it is a bit more cumbersome and requires collecting data for a large number of communities before beginning implementation, this method is often not practical in view of available resources and time constraints. (See Appendix I for a list of criteria for a hypothetical project.)

### 3.3 Village Profile Information

A village profile identifies the major factors that influence the long-term viability of a community water supply. It seeks to produce a picture of the basic social, economic, and administrative structure of a community together with basic technical information. It includes information on the values, needs, perceptions, and motivations of the water system users. The profile should be considered in the planning stage of any water project to determine what information is relevant for the geographical areas under consideration. Some information, such as village administrative structure and certain cultural factors, may be basically the same for all locations. Thus, the general information collected for the region or country as a whole will be adequate. Other information, such as health statistics, while highly desirable, may be either unreliable or unavailable; but it may be possible to use regional or countrywide figures. Still other information, such as population, present water sources, and water use habits, is highly specific and must be collected for each site.

To ensure proper site selection, a village profile must be prepared for each potential site. Preparation of the profile will require site visits and the assistance of the local community. However, additional information should be obtained from those outside the community, such as government officials or community development workers who are familiar with the area and can provide a different perspective. Information to be included in the village profile will vary according to the project goals, type of water systems under consideration, geographical considerations, and cultural factors. The outline presented below contains a list of important factors to consider in preparing the survey forms for the village profile. (A sample village profile questionnaire is included as Appendix II.)

The village profile is usually not sufficient in itself to identify appropriate villages for water system installation but provides a preliminary screening which must be verified by more detailed investigations concerning community preparedness and technical feasibility.

#### 3.3.1 Basic Village Data

The following list shows the kind of questions that should be asked in preparing a village profile. The most important are marked with an asterisk.

---

\*What are the names of the village, the region, and the locality?

\*What is the present population?

\*Is the settlement type concentrated or dispersed? Fewer water points are required to provide adequate access in an area of concentrated settlement than in one where dispersed dwellings exist.

What is the distance between the community and reliable transport to the nearest town?

How good is access to the village? Are roads closed seasonally?

What is the community's administrative structure?

\*What types of organizations or committees exist? How often do they meet?

Is there a village telephone or radio for communications?

\*Has the community completed any previous self-help projects? Give examples with details on type, cost, source of funds, time period for completion, when done, and names of organizers.

\*Has the community failed to complete any previous local projects? Give details.

\*What are the main groups in the community and what is the basis of their affiliation (economic, social, ethnic, religious, familial, political)?

Do the residents of the community own their land? Are they "squatters" or refugees?

What are the sources, if any, of conflict between community groups?

\*Who comprises the dominant groups?

How are community decisions reached, and who participates in the process?

What is the extent of women's involvement in community decisions?

---

### 3.3.2 Perceived Needs of the Community

---

What do villagers and village officials regard as the most pressing community problems or needs?

\*Do any groups or individuals in the community regard water supply as a problem area? If so, which groups are they and what do they consider to be the problem(s): quantity, quality, proximity, reliability, competing users, etc?

\*What priority does the community assign to water supply improvements in relation to other needs?

- a. other problems should be solved first
- b. ranks equally with other problems
- c. more important than other problems

\*What are women's perceptions of the problems and needs concerning community water supply?

\*Has the community previously done anything to improve its water supply? If so, what has it done?

\*What level of service and type of water system (i.e., gravity-feed piped, handpumps, etc.) does the community expect? Are private connections required?

---

### 3.3.3 Water Uses and Sanitation Practices

---

\*What are the present sources of water, both public and private? Indicate if they are used year round and tell what they are used for.

\*If a water system exists, what percentage of people use it? Does it supply sufficient water for all needs?

\*What is the distance from the center of the settlement or household to the most frequently used water source? What is the time required for a round trip?

\*Are separate sources used for drinking and other uses?

\*What is the average time spent collecting water? Is it collected daily or at other intervals?

\*What are the uses of water? Rank them in order of perceived importance.

What use consumes the largest quantity of water?

\*Is water used at the source or carried to another place?

Is water stored? If so, where and how?

Who collects and brings water to the home (men, women, or children)?

What qualities do people most value in their water supply: taste, color, odor, convenience, reliability, or perceived health value?

Do water collection needs cause children to miss time in school?

What are the methods of excreta disposal?

Do people boil the water they drink now?

---



### 3.3.4 Technical Data on Available Water Sources and Their Uses

\*Describe sources of pollution for water sources used currently.

\*Could the present source be improved? Is its capacity adequate year round?

\*What other sources are available?

\*Do any wells exist? Are they dug or drilled? Has any drilling been attempted? What is the average depth of existing wells?

Has the present source been tested for bacterial quality? If so, what were the results?

Are skilled workers available for project implementation?

How important is a watering place for domestic animals?

Do any existing village industries use water?

---

### 3.3.5 Financial Data

---

What are the main sources of community income?

What is the average income? Are large segments of the community below this level?

What is the percentage of community income from remittances from family members or other residents who live outside the village or community (0-30%, 31-70%, 71-100%)?

What are community attitudes about paying for water? Is it regarded as a free good? What are attitudes about paying for water system maintenance?

\*What are community members most willing and able to contribute toward an improved water supply (money, labor, materials)?

Are the people able to pay as much as they say they are willing to?

Have the people successfully handled common funds to implement other projects? Is this done routinely? Is there mutual mistrust concerning handling of common funds?

Will any water carriers or vendors lose their livelihood because of the project? Could such people be trained for operation and maintenance responsibilities in the new system?

---

### 3.3.6 Resources for Operations, Maintenance, and Training

\*Does any kind of water committee exist at present?

\*Does anyone maintain the present water source?

Are there any regional or national systems to assist in operations and repairs? What services could they reasonably be expected to provide?

\*What group of the population will control the water system when it is completed?

Are skilled workers available for repairs (mechanics, plumbers) or must people be trained?

Are there tools locally available? spare parts? fuel?

---

### 3.3.7 Village Health Status

---

\*What do people feel are the most important health problems/issues?

\*Are any health records available?

\*What medical facilities are present in the community: hospitals, clinics, doctors, health workers, volunteers? Do all people have access to them?

What diseases are most common?

Do any health workers from outside regularly visit the community?

---

## 3.4 Other Studies and Surveys

In addition to the essential village profile several other types of surveys or studies may be desirable. They include the following:

### 3.4.1 Technical Surveys

Technical surveys may be required to determine feasible types of water systems, locate the most suitable water source, or obtain cost estimates. If a survey is not required for these purposes, it may be required for design preparation depending on the type of water system under consideration.

### 3.4.2 Water Usage and Sanitation Studies

Often, water use and sanitation habit surveys referred to as KAP surveys (knowledge, attitudes, and practices), are conducted. If such information is not available from previous studies of the area, then the KAP survey should be implemented in the planning stages of the project. Information from such a survey is necessary to orient project design, formulate goals, plan health education and sanitation activities, and guide technicians in water system design. (An example of a KAP survey can be found in Appendix III.)

### 3.4.3 Household Surveys

Detailed household surveys on water usage should be conducted to obtain baseline data for evaluation purposes. In many respects, these surveys may be similar to the KAP survey; but they are generally performed later as actual villages are selected for implementation. Household surveys would not necessarily be conducted in each village but more likely only in a representative sample of villages. They commonly include a sample size of 20 percent of the community. They should be conducted initially before any project activities begin, then the same villages are normally surveyed again a few months after the water system has been in operation.

## 3.5 Survey Methods

A baseline survey can provide vital data for project planning as well as for later monitoring and evaluation activities. In order to achieve useful data with the least amount of bias in a small-scale, localized survey, such as the village profile, there are a few basic methodological issues to consider concerning the sources of information, sampling techniques, and interview methods.

### 3.5.1 Sources of Information

Survey information can normally be collected from one or more of the following sources: government data; in-country experts who may be connected with the government, a university, or an international organization; observation by field staff; and interviews with community members.

Many governments will possess basic, large-scale data on their country's geological features, population composition, morbidity and mortality rates, agricultural activities, and so forth. These data can be used to provide an overview of the situation in the country at large; and as specific local information is generally not available, they will provide proxy information on regional and local conditions. The overall reliability of the data as well as the accuracy in reflecting local conditions will vary from country to country.

### 3.5.2 Sampling Techniques

Ensuring that one has questioned a representative sample of the local population is perhaps the most important factor in assuring a valid baseline social survey. Designing statistically reliable samples is, in itself, a complicated process, and sophisticated techniques are difficult and expensive to carry out in the field. A brief discussion of the two main sampling techniques, non-probability sampling and probability sampling, will provide some simple and useful guidelines which can be delved into in greater detail if desired by consulting any text on sampling methodology.

Non-probability sampling is so named because it does not give each member of the community an equal chance to be randomly selected for an interview nor does it allow all possible groupings of people to be polled. As a result, the survey results may be highly biased, though it is impossible to measure the degree of bias. The main advantage to non-probability sampling methods is that they are easy and inexpensive.

Investigators can use several methods to select a non-probability sample. (1) They can simply question whomever they encounter or choose to question until a large enough sample is obtained. (2) They can subjectively divide the population according to certain characteristics, such as age, sex, and economic status and then interview members of each group. (3) Finally, they can select "typical" individuals or communities to interview and extrapolate these data to obtain information for an area or region. All these methods provide questionable results of no statistical reliability, although the second affords much more control over efforts to gather useful information.

Probability sampling can be done in numerous ways. The most useful techniques for the purposes of the baseline village profile survey described here are the simple random sample, systematic sampling, and the stratified random sample. These techniques seek to provide every individual or group in the target population an equal chance of being interviewed.

A simple random sample can be selected in several ways. If the population is small, names of community members can be drawn in a lottery until enough names are selected to provide a representative sample of the community. For a larger population, a table of random numbers from a statistics text can be used to obtain a representative group of people to interview. Each member of the community is assigned a number. Those who receive a pre-selected number are interviewed. If a list of residents is not available, it may be necessary to conduct a census or map households and sample those.

Systematic sampling is a form of quasi-random sampling which can be used if a list of community residents (presented in a non-systematic, ungrouped manner) is available. A random spot on the list is chosen. Then every individual whose name appears at a regular, predetermined interval is selected for an interview. For instance, every fourth name on the list, beginning at random, may be chosen for an interview.

The stratified random sample uses the same method as the simple random sample but first breaks the population down into two or more groups based on sex, income, education, and so forth. This usually requires some more detailed knowledge of the population but helps ensure that important subgroups are not overlooked.

Responses may be expressed as a percentage of the total population or a percentage of those interviewed. The number of individuals in any group interviewed may be larger or smaller than their actual share in the total population.

### 3.5.3 Interview Methods

Effective interviewing requires sensitivity from the interviewer plus understanding and trust on the part of the respondent. For a variety of reasons, people are often highly suspicious of any survey and so may be reluctant to cooperate unless the purpose of the survey is clearly understood. In addition, questions should be asked in a standardized manner. Varying the phrasing of a question may yield different interpretations of that question and a variety of answers which are useless for determining specific information on one issue. The questions must be clear and understandable to the interviewee, and phrasing which suggests what the polite or "correct" response is should be avoided. Follow-up questions can be used to determine if cultural or language differences are causing questions or answers to be misinterpreted. Where possible, country nationals with training in survey or interview techniques should be used. In any case, all interviewers must be thoroughly trained and tested.

Some project staff should be used for survey work. This will help them to become familiar with the areas they will be working in and to establish relationships with the community. Care should be taken during all surveys not to give the community the impression that they will receive a water system as a result of the survey.



## Chapter 4

### DETERMINING RESOURCE NEEDS

Human, financial and material resources are all needed for water and sanitation projects. Resource needs should be considered in the context of three project phases: design, construction, and operations and maintenance (including repair). Depending on the type of water or sanitation technology chosen, the type of overall project, and the project phase, radically different amounts and types of resources may be required.

#### 4.1 Human Resources

During the technical design and construction phases of a project, the availability of professional technical assistance can be crucial to water and sanitation activities. Key skill areas in this regard may be survey design and analysis, the design of water supply and sanitation systems, and construction supervision. Access to unskilled labor is also necessary but usually less of a limiting factor because this resource is almost always available locally. (Illustration 3 is a photograph of the workforce available in a Bolivian village.) After project design and construction, access to skilled labor is important but it is not so critical that skilled laborers must be on-site at all times. Structured technical orientation sessions can be conducted which train relatively unskilled labor to carry out most of the operations and maintenance functions (including repair) with technicians being called in occasionally to handle particularly difficult tasks. For example, villagers can usually be trained to maintain the above-ground parts of a handpump, while below-ground maintenance is far more difficult and usually requires more experienced technicians. USAID, UNICEF, and the U.N. Development Programme have all implemented types of training programs in cooperation with host-country agencies for both villages and technicians.

Individuals with expertise in management and administration, communications, community development, and education are just as important as those with construction skills. Frequently, construction of a potable water system is the first large project a community undertakes. At the beginning of the project, community planning and assessment work (e.g., household surveys, inspections) must be carried out. Health education, especially user education, must be initiated. Furthermore, in almost all cases, water programs require the establishment of a local system for managing both capital and recurrent expenditures. As a result, there is usually a need for people with skills in survey design and implementation, community organization ("animateurs"), interviewing, fund-raising, budgeting and financial management, health education, teaching, or public speaking.

The long- or short-term staffing of water and sanitation projects may be done in many different ways. Both skilled and unskilled labor have important places in all phases of projects. Figure 2 gives examples of staffing patterns for three CARE projects showing the mix and usage of different labor sources for specific in-country activities.

Belize Village-Level Water and Sanitation Project

Pre-MYP project design: 2 CARE/Belize office staff  
1 CARE/New York health officer  
1 expatriate water and sanitation consultant

Post-MYP project design and implementation:

CARE/Belize long-term personnel

- 1 health education specialist from the U.S.
- 1 water and sanitation engineer from the U.S.
- 1 project coordinator from Belize
- 2 region-specific coordinators from Belize

Other personnel

- 1 health education/audiovisual consultant for two months from USAID's MEDEX Project
- 1 water and sanitation survey consultant for two months from USAID's WASH Project
- National-level public health inspectors, well-drillers, and health education specialists from the government of Belize
- Village-level labor (not paid) for project committees, survey implementation, all construction activities, and operations and maintenance

Haiti Community Water Systems Development Project

Post-MYP design and implementation:

CARE/Haiti long-term personnel

- 1 water project manager (engineer) from the U.S.
- 1 water and sanitation engineer from the U.S.
- 1 health education advisor from the U.S.
- 1 community organization specialist from Haiti
- 1 warehouse manager from Haiti
- 1 accountant from Haiti
- 1 secretary from Haiti
- 1 administrator/purchasing agent from Haiti
- 3 teams of Haitians composed of an engineer, a community development specialist ("animateur"), a mason, a plumber, a foreman, a truck driver, a driver's assistant, and a health promoter.

Indonesia Community Water Systems Project

Post-MYP design and implementation:

CARE/Indonesia long-term personnel

- 1 water and sanitation engineer from the U.S.
- 5 water and sanitation field officers from Indonesia

Other personnel

- 1 health education consultant for one month from USAID's WASH Project
- 1 evaluation consultant for one month from USAID's WASH Project

Figure 2. Sample Staffing Patterns



As Figure 2 reveals, labor sources can include:

- in-country resident and non-resident CARE staff
- CARE, New York staff
- host-country government staff
- local residents
- short-term consultants from sources outside CARE.

During project design and prior to submission of the MYP, an assessment of the required technical and non-technical labor for all ensuing project activities takes place. Figure 3 provides a checklist for doing this. The three most important questions to find answers to are:

1. What can be contributed by host-country sources at all levels (village, regional, or national)?
2. What long-term CARE staff inputs will there be?
3. What types and amounts (in person-days) of highly technical short-term labor are needed to complement and enhance the design, implementation, or evaluation of the proposed program?

The cost implications of each alternative are discussed in the next section. Typically, forecasting availability of host-country government personnel is difficult.



Illus. 3. Available human resources in a Bolivian village.  
(Source: WASH Project.)

Available In-Country  
Yes                      No

<u>Yes</u>	<u>No</u>	
		<u>Project Design</u>
_____	_____	budgeting
_____	_____	water supply technologies
_____	_____	sanitation technologies
_____	_____	health education
_____	_____	survey design and implementation
_____	_____	monitoring and evaluation
_____	_____	community development
_____	_____	operations and maintenance systems
		<u>Project Implementation--Management, administration, and general technical</u>
_____	_____	financial management
_____	_____	monitoring and evaluation systems
_____	_____	vehicle maintenance
_____	_____	survey enumeration
_____	_____	audiovisual development
_____	_____	community development
_____	_____	ferrocement construction for water or sanitation
		<u>Project Implementation--Water systems</u>
_____	_____	handpump manufacturing, installation, and maintenance
_____	_____	gravity-feed water systems installation and maintenance
_____	_____	well and spring siting (i.e., geohydrology)
_____	_____	diesel/gasoline pump mechanics
_____	_____	wind system mechanics
_____	_____	photovoltaic systems
_____	_____	hydraulic ram systems
_____	_____	water treatment systems
_____	_____	bacteriological/chemical water testing
_____	_____	water system training
_____	_____	water system financing
_____	_____	water-related epidemiology/health analysis
_____	_____	plastic, bamboo, or ceramic pipe manufacturing
_____	_____	"gray-water" system design
_____	_____	water users' association design and analysis
		<u>Project Implementation--Sanitation systems</u>
_____	_____	pit or VIP latrine design and construction
_____	_____	aqua privy design and construction
_____	_____	water-borne sewage and sanitation system design and construction
_____	_____	showers (public or private)
_____	_____	drainage
_____	_____	clothes-washing areas (public or private)
_____	_____	dish-drying racks

Figure 3. Technical Skills Availability Check-off List

## 4.2 Procurement of Human Resources

The scale and breadth of water supply and sanitation projects often require substantial technical resources not found in many communities. As a result, access to national or foreign human resources can be quite important. Obviously, the participation of local residents should always be stressed, particularly in terms of supplying unskilled labor. It is hoped that such labor will be offered by local people without charge. Both CARE and USAID have previously used P.L. 480 funds to provide food in exchange for labor. However, in some countries (e.g., Haiti), paying local residents to work has reduced local willingness to engage in various kinds of self-help projects and has had a long-term negative effect on development.

In terms of local human resources, "hands-on" skills are those which are most commonly found, including:

- masonry (concrete and ferrocement)
- plumbing
- carpentry
- well-digging
- installation and repair of electrical systems
- diesel or gasoline engine mechanics.

To complement these local skills, non-local, national, or international sources of expertise have to be tapped. Outside the immediate project site, individuals with the technical qualifications needed for water and sanitation projects may be found in various places:

- government agencies, such as urban water and sanitation, planning, education, or financial management
- technical schools and universities
- nonprofit special interest groups (e.g., environmental organizations)
- private service or manufacturing companies (plumbing suppliers, pipe manufacturers, electrical contractors, well-drilling outfits, etc.)
- private consulting firms.

At the international level, there are a number of established sources for water and sanitation expertise in both the private and public sectors. Major sources of technical information and of short-term technical personnel include:

- Water and Sanitation for Health (WASH) project funded by USAID, 1611 North Kent Street, Suite 1002, Arlington, VA 22209. Cable address, WASHAID, telex number 64552.

- WET project at UNICEF, 866 U.N. Plaza, New York, N.Y. 10017. The contact person there is Per Engebak; the cable address is UNICEF, New York; and the telex number, 62346.
- Energy, Water and Telecommunications Department, Water Supply and Sanitation Research Project of the World Bank, 1818 H Street, N.W., Washington, D.C. 20433. The contact is Saul Arlosoroff; and the cable address is INTBAFRAD, Washington, D.C.

Private nonprofit organizations in the United States, Canada, Europe, and Asia that have relevant publications and strong backgrounds in water and sanitation include:

- International Development Research Centre (IDRC), P.O. Box 850D, Ottawa, Canada K1G 3H9. The contact is Donald Sharp, and the telex number is 053-3753.
- Asian Institute of Technology, P.O. Box 2754, Bangkok, Thailand. The contact person is Dr. Robert Banks.
- International Reference Center for Community Water Supply and Sanitation (IRC), P.O. Box 93190, 2509 AD The Hague, Netherlands. The contact is Hans Van Damme, and the telex number is 33296.

Obviously, there are many other institutions that can be of assistance, such as private consulting firms that focus on water and sanitation, including engineering, research, public health, and training firms. In fact, the WASH project is implemented by a consortium of consulting and research organizations under contract to USAID. The first three organizations mentioned above (WASH, WET, and the World Bank) are consistently interacting on water and sanitation research and projects and, in many cases, have already provided assistance to CARE on other projects. In each instance, the liaison between field staff and the international source of expertise is coordinated by CARE, New York.

CARE, New York also has established relationships with a number of independent consultants who provide short-term assistance to CARE periodically. Furthermore, numerous CARE staff members themselves, employed as project managers, regional technical advisors, or at CARE, New York, are well-qualified and can respond to many of the questions and issues that arise at the various stages of water and sanitation projects. CARE, New York staff also function as coordinators of international technical aid to CARE field projects.

### 4.3 Material Resources

Material resources are needed for (1) project administration, (2) education, and (3) water or sanitation system construction or operations and maintenance. Usually, the construction phase of a project is most demanding from a material resources perspective. Construction (or preconstruction) materials commonly required for water and sanitation systems include:

- sand (this might be gathered by the community as in Illustration 4)
- cement
- stone
- reinforcing wire or steel
- metal, bamboo, ceramic, or plastic pipe
- pipe fittings
- wood
- fuel for engines
- water
- water-testing kits or laboratories
- basic tools (shovels, pipe or "nut" wrenches)
- hand-, wind-, solar-, gasoline- (or diesel-) powered pumps
- well drilling/digging equipment
- chlorine.



Illus. 4. Sand gathered by villagers for mixing concrete.  
(Source: UNICEF.)

A shortage of or delay in acquiring any of the above materials may either severely limit the type of construction that can be accomplished or disrupt project schedules. At the very least, shortages or delays will raise construction costs. Adequate consideration should also be given, over the long run, to spare or replacement parts and tools for maintenance or repair. (Chapter 7 contains a list of these.) Obviously, the availability of materials needed for repair and maintenance should be considered during project design because it often determines the type of water or sanitation technology selected for a particular situation.

Material resources often required for education include:

- slide, movie, or filmstrip projectors
- construction paper or other drawing materials
- movies, filmstrips, photo-novels
- electrical generators
- cameras and film
- copying, printing, or mimeograph services
- film developing and printing or poster-making facilities.

The management and administrative resources required are not usually distinct from normal office supplies. The most important difference in resource needs is access to vehicles, particularly pickup trucks, for transporting materials.

## Chapter 5

### DESIGNING THE PROJECT

Many of the critical issues pertaining to long-term benefits and reliability can be addressed during the design phase of water supply and sanitation projects. The design of a project is that step in project development where the implications of site selection and resource availability are worked out in a specific project plan that can be implemented. Certain aspects of project design are of general relevance to CARE water supply and sanitation projects. If these are carefully taken into account, projects will have a greater chance of success; but, of course, implementation issues (see Chapter 7) can and will influence the eventual outcome of a project. These six basic aspects of project design concern (1) health benefits, (2) community participation, (3) financing, (4) community education, (5) maintenance, and (6) complementary sanitation programs. Each of these aspects will be discussed in this chapter.

#### 5.1 Maximizing Health Benefits

Although it is difficult to measure the health benefits of water supply and sanitation projects, planners can make sure their projects exploit every opportunity to assure positive health benefits. That means trying to affect the quantity and quality of new or improved water supplies, to prevent secondary contamination of supplies, and to encourage the proper use of the new or improved supply as well.

##### 5.1.1 The Quantity of Water

The first objective is to assure that there is enough water. The quantity of water consumed per person per day may be the most important single measure of water supply to a given population. Water for handwashing, bathing, and laundry as well as for drinking and cooking must be in sufficient quantity (minimally 20-30 liters) to prevent childhood diarrhea, dysentery, trachoma, skin diseases, and other infections borne by hands or food.

A limit on the quantity of water consumed per person is set by the volume the various water carriers in a household can carry a day if no home taps are available. That volume varies in turn with the distance from home to the water source, the duration of waiting at the source, the size of the carrying vessel, strength of carrier, and the output of the source itself. (Illustration 5 shows a group of people waiting to draw water from a community well.) Project planners can affect these variables by assuring a sufficient output from the source, whether the flow comes from a spring, gravity system, or well, and by planning enough sites to keep site/population ratios between 1:100 and 1:200.



Illus. 5. Drawing water from a well built with UNICEF assistance. (Source: UNICEF/Niger, photo by Anne Marie Gaudras.)



Installation of new water supplies does not generally increase the quantity of water used per person per day unless the water point is at least in the yard. It is, therefore, best to bring the water point as close to the users as possible. The more numerous the sites in a given community, of course, the less the distance from home to site and the less the waiting in line. Flow from a spring or stream should be assessed for adequacy in the beginning of a project. Frequently, a spring can be enlarged to include other galleries so as to increase the flow. A well must be dug or drilled deep enough into the aquifer to assure an adequate recharge rate.

Finally, handpump efficiencies vary from model to model. Some, such as the India Mark II, have quite favorable work/output ratios.

Despite such efforts to assure adequate amounts of water to communities, the limit of how much water can be carried per household per day is still critical. Encouraging the use of larger carrying vessels would provide a marginal increase in volume. If several trips to the site each day are possible, the volume can be doubled or tripled. Another possibility is to encourage use of water at the source by constructing bathing areas and washing slabs and sanitary facilities at the site. Then, the only water carried to the home may be for drinking, kitchen use, or housecleaning. Naturally, a source of water brought to the yard or into the house represents the best alternative.

### 5.1.2 The Quality of Water

The quality of water consumed is the next most important consideration. Project planners should assure the maximum protection possible: springs should be closed in, the source of a gravity system should be protected from encroachment by humans or domestic animals, and wells should be sealed or at least covered. (A well-protected water source is shown in Illustration 6.) It is desirable to seal the cover on a well by means of a handpump; and yet because of the difficulty of keeping a handpump maintained, one must frequently compromise the quality of water produced by leaving the well open. Covers must be of the right weight if they are to be used consistently. If they are too heavy, they will be removed by the population to permit easier access to the well. Those that are too light will be found more on the ground than over the well.

Much of the difficulty surrounding the sealing of a well stems from the fact that the issues both of well protection and well access must be addressed. If a well is sealed with a pump, only one woman at a time has access to the water and others are forced to stand in line--frequently for a long time in the hot sun. Two pumps on a single well offer a limited solution to the problem. If the well is open, the danger of contamination increases as buckets and ropes are left on the ground and then plunged into the water. If a single bucket and pulley system are used, greater protection is assured but access is reduced. Thus, it is not easy to decide whether or not to seal a well. Community participation in deciding this issue is critical to devising a workable solution.



Illus. 6. A protected well. (Source: Bob Blankwaardt, Hand Drilled Wells: A Manual on Siting, Design, Construction and Maintenance. Rwegarulila Water Resources Institute, Dar Es Salaam, Tanzania, 1984.)

### 5.1.3 Secondary Contamination of Water

If it is not possible to have a source of water satisfactory in all respects at the beginning, one should plan the water supply development of a community in a step-wise or incremental manner. First, assure that enough water (20-30 liters per person per day as a minimum) is available at the source; and then, in subsequent phases, assure that there are enough sources to minimize walking and waiting in line; and finally, assure that any qualitative deficiency in the water is corrected as much as possible. An important aspect of assuring water of adequate quality is to keep storage jars clean and covered. (See uncovered jar in Illustration 7.)



Illus. 7. Water storage in an earthenware jar. (Source: WASH Project.)

The secondary contamination of a water supply is brought about by water left standing around the source as a result of spills or leaks. Such water is a frequent site for larval breeding of mosquitoes, both the variety that transmits malaria and the one that transmits Bancroftian filariasis (elephantiasis). Project designers can avoid this problem by providing for the construction of an apron around the well, inclined so that water runs into a drainage canal and then to a soakaway, a garden, or an animal watering trough. Water should likewise be drained around and away from a spring.

In areas of the world where livestock are raised, project designers also must find ways to prevent animals from encroaching on the site. Such encroachment combined with poor drainage leads to the formation of a muddy slough that women and children must pass to get to the well. A carefully built fence around the well site can effectively prevent the entry of cattle, and an animal watering trough at a safe distance from the well can provide animals with an alternate source of water.

#### 5.1.4 Complementary Activities in Sanitation and User Education

Complementary project inputs in sanitation and user education are necessary if health benefits are to be achieved. Although such program elements will be discussed in more detail later in this chapter, they should be mentioned here as a part of what is essential in a project to maximize health benefits.

Sanitation refers not only to excreta disposal, as important a matter as that is, but also to aspects of personal and domestic hygiene, food hygiene, housing, and control of intermediate hosts of diseases. Many populations do not believe that sanitation measures are as important as a convenient, reliable water supply nor do they understand that sanitation may in fact be dependent on an adequate supply of water. Project planners should be aware of the relationship between water and sanitation and should plan sanitation components in a progressive, incremental fashion, perhaps leading from an adequate water supply to handwashing and bathing to food hygiene to excreta disposal. Trying to promote hygienic excreta disposal in a water-short population may be self-defeating because "beneficiaries" often are not interested.

An educational program to accompany the inputs mentioned above is essential. The first objective of the program is the active participation of the population in the water supply improvements. Then whatever group has been set up to organize participation--a village health committee, for example--can begin to take on tasks related to hygiene and sanitation. An informal participatory structure such as a committee, compared with the traditional style of formal educational programs, has the advantage of translating the message into local terms and planning appropriate actions for guiding and pressuring the population to conform with certain norms of behavior set by the committee itself. Fashioned in such a manner, an educational program helps to round out the essential elements of a project seeking to maximize health benefits.

## 5.2 Optimizing the Participation of Communities in Project Design, Implementation, and Evaluation

Communities, including women where possible, must be involved in the design of a development project if their participation in later stages of maintenance and repair is to be expected. Most project designers have little difficulty accepting this premise. Much greater difficulty is encountered in knowing how to implement project elements leading to active participation by communities.

It is first useful to discuss just what is meant by the term community and then to proceed with some notion of how to undertake actions leading to participation in a water supply and sanitation project.

Some analysts think of a community as a village with an ethnically and linguistically homogeneous population where a chief or headman has authority over all the people who, in fact, trace their ancestry to his forebears. While such villages do exist and do make development work easier, they are outnumbered by villages that are not homogeneous; chiefs that are not authoritative; and populations that don't live in villages but under dispersed sedentary, nomadic, or urban conditions. The community with which one must work may therefore not coincide with the geographic bounds of a village but may be made up of people bound by a common interest, often an extended family or clan. In some cases that unit may be so small as to discourage water supply development, unless communities find it possible to merge their interests. In fact, considerable time may have to be expended just helping people to find a common interest in water supply and sanitation.

How can participation of a community be promoted in the design of a water supply and sanitation project? There are several principles that should be adhered to.

### 5.2.1 First Principle -- Allow Enough Time to Promote Participation

A major difficulty of many projects is not only that time sufficient to foster community participation is not provided but also that those responsible for this program element find themselves attempting to "catch up" with the water supply technicians throughout the life of the project. The time required to promote participation varies from a few days to a few months, depending on the state of readiness of the community. Six months to a year or longer may be necessary to prepare communities to participate before a spade is set to the soil.

#### Community selection

In considering the potential of communities to participate in a water supply and sanitation program, one should ascertain which communities have in fact participated successfully in projects during the recent past. Past projects which may demonstrate this include the "community" construction of a school, a mosque, a road, a teacher's house, or anything that gives evidence of a local ability to collectively plan for, gather resources for, and bring to completion an agreed-upon project. Although these experiences may not

completely predispose a community to participate in a water supply and sanitation project, they form the best single prediction of success in participation. Of course, this factor must be balanced off against others (need for water, technical feasibility, and other incentives to participate in a given project).

Other criteria of lesser importance include effective leadership as judged by the ability to gather resources for the community and to maintain order, the existence of strong local organizations, or ethnic homogeneity.

In the ideal situation, one enters a community with an open agenda allowing community members to define the problems. Most field workers operate, however, within the context of a project.

#### Community entry

Having learned as much as possible about the communities of an area, field workers should begin the process of preparing the communities selected for participation in the project. The first step, commonly called entry, is to hold a meeting with community leaders in which the project is explained and expectations of the community are elicited. (Such a meeting is shown in Illustration 8.) To the extent possible, women, as the drawers and carriers of water, should participate in this and subsequent meetings.



Illus. 8. A village meeting in Bolivia. (Source: WASH Project.)

The field worker may leave this initial meeting with a clear idea of what the community is capable of and willing to do. But it may take several meetings to arrive at this point. If local people are clearly hesitant or do not fully understand the project and its implications, the wise field worker will allow adequate time between meetings so that villagers can discuss the project repeatedly and think it through. As community members gradually learn more about the proposed activity, they will be better able to assess realistically what they want and what they can afford in terms of labor, material, and cash investments. This process of negotiation may very well involve some adjustment in the project goals as initially conceived by the field worker and his supervisors. This is as it should be. Patient, careful preparatory work during the initial period will almost always pay off one way or another. Leaders and users will understand far more clearly what they are committing themselves to and what they will get for the effort. They will then either decide to reject the project because they judge it not to be worth their while, or they will press ahead. In the first case, it will become evident that scarce funds can be spent more efficiently elsewhere. In the second, problems during construction and maintenance phases will likely be minimized.

Once this point is reached, some organization will usually be established to take charge of the project. This organization might be an existing body such as a village council or a village development committee. Or, it might be specially created for the purpose: a water committee or a health committee.

#### Organization and training

Following entry, a general meeting of the community is arranged at which the leaders present the project as they see it, the committee is introduced; and the field worker adds details on what the committee will do regarding the planning, implementation, and maintenance of the water supply and/or sanitation improvements. Use of appropriate visual aids to transmit messages is helpful at this point.

The field worker works with the committee to help it define its purpose, elect its officers, define its program, and characterize its relationship to the rest of the community.

The project should include enough time and resources to carry out a training program for the local committee. There are a number of training needs. The entire committee should be trained in their role as health leaders in the community and in the rudiments of a problem-solving methodology. In addition, the officers (presidents, secretaries, and treasurers) may need training to carry out their specific roles (e.g., group dynamics, communications, non-formal education, etc.).

#### Problem solving

The field worker should work with each committee for a month once members have been trained in problem-solving methods to help them with the following processes:

- **Identification of problems** related to water supply and sanitation, such as diarrhea, women walking a long distance, water with a bad odor, etc. If necessary the committee conducts a household survey to determine what problems are perceived by the people (see above, Section 3.4.3).
- **Selection of one problem** to work on first. Selection is made by means of a simple scoring system involving an assessment of the severity and the extent (number of people affected) of the problem. For example, diarrheal disease may be the problem cited. Its severity could be assessed by counting the number of children who died or who made a clinic visit for diarrhea in a given period; its extent, by counting the total number affected in the same period. Committee members could gather this data through household visits or through a general community meeting.
- **Analysis of the problem.** Factors that cause the problem or that aggravate it are identified. Then, those that keep it from becoming worse are identified as well. Example: diarrhea is the problem. Indiscriminate defecation is a factor that causes it, but breastfeeding until two years helps to control it. After all these factors have been identified, those that the community cannot affect are eliminated. Those that the community with its resources can affect are retained in the list.
- **Selection of a solution.** From the list of factors remaining, the committee selects those it wants to work on. The field worker helps the committee organize the suggested solutions into an acceptable package. It is at this time too that the field worker can arrange to have a technical expert come to present a series of technical options from which the committee can choose.

Of course, the solution eventually adopted will be to a greater or lesser extent determined by what the project has adopted as an acceptable technical package. A well-drilling project will offer only one technical solution to the problem although the well/population ratio, well-siting, and well protection may be amenable to community-initiated modifications. Project planners must decide in advance on the range of technical options compatible with a cost-effective approach to improvements in water supply and sanitation. Leaving some margin for community decision-making in these matters is an important part of optimizing participation.

#### Development of a work plan

The package of solutions having been accepted, including that which the project will accomplish, the committee is then ready to lay out a scheduled work plan, including the designation of who will do what and when. In initiating the process, the field worker and the committee might organize a ceremony at which a contract is signed between the agency (CARE) and the community.

During the time designated for developing the work plan, construction and maintenance workers should be trained and arrangements made for obtaining materials and technical expertise from outside the community. These activities



should be coordinated with scheduled visits of various teams during the installation of the system. For example, when the pump installation team comes, it should plan to train the local pump caretaker by having him or her take apart and reassemble the pump.

The work plan is usually developed in concert with the water supply and sanitation technicians of the project. Once the plan is complete, the community should be ready to participate actively in the implementation phase of a project. If the community is ready, (1) it will have formed a viable organization, such as a health committee, to coordinate local participation; (2) members of the committee will be trained for their respective roles and in problem-solving techniques; and, most important, (3) committee and other community members will already be involved in planning the project as it pertains to their locality.

#### **5.2.2 Second Principle -- Participation Must Involve Actual Decision-Making**

If the procedures of the first principle are followed, then project inputs will be effectively used by local populations to meet locally perceived problems. In fact, if communities really participate in actual decision-making, they tend to continue to participate in the maintenance phase of a project when systems break down and need repair. If all they do is contribute labor and materials, they are not likely to remain involved. Examples of decisions that the community can make include site selection, the number of water supply installations, the technology employed, the design of excreta disposal facilities, and the financing plan for construction and maintenance. Project planners should allow for such decision-making from the early phases of the project. Villagers should be told in terms they can understand what options are available to them, and they should feel that their opinions are carefully considered and given proper weight.

The same principle applies to community participation in project evaluation. It is not sufficient to present communities with the results of an evaluation. If the population has a sense that the water supply or sanitation facility belongs to them, then they will have a stake in the formulation of evaluation questions, in the collection of data, and most of all in the interpretation of results. Project planners should allow for such participation in evaluation by making provision for it from the beginning.

#### **5.2.3 Third Principle -- Train All Project Staff to Support Community Participation**

All staff (social, health, and technical) should support the process of community participation as described above. Sensitivity training of staff not directly involved in the process--well drillers and diggers, pump installers, masons, sanitarians, and others--is useful to help them set a tone of support to local participation and at the least to prevent their undermining the process. Consideration should be given to removing staff who talk down to villagers or otherwise abuse their authority.

Sensitivity training could be carried out in two- to three-day workshops held periodically. The workshops could feature problem-solving exercises and simulation games centered on issues related to the staff's roles in dealing with communities. Alternatively, technical staff and staff directly involved in promoting community participation may be trained together, even if for only a few days. Then, a more coordinated approach to communities could be adopted. For example, when they needed technical advice, the health or social staff could easily call on technical staff because they would know them personally. They might need advice in selecting a site for a new water supply, selecting a water supply technology, evaluating an existing well for the possibility of deepening it, or designing a latrine.

#### 5.2.4 Fourth Principle -- **Take Steps to Assure Sustained Participation after the Project Is Complete**

It takes from three to 10 years for communities to achieve a degree of autonomy in managing their water supply facilities. Regardless of how long it takes, however, the six months pre-project planning is not enough. Time should be planned for sustaining the process through several rounds of problem-solving. First, the community must deal with the problems they identified in the planning stage. In addition, problems will arise during the maintenance of water supply and sanitation facilities. These all must be solved, and the problem-solving process will become a useful tool in the hands of an organized community for resolving problems of many different kinds.

Project planners should allow sufficient time and resources to permit communities participating in a project to achieve a defined level of autonomy. Many problems arise as communities work toward such autonomy. Communities that are not ethnically or linguistically homogeneous will need time to resolve long standing issues that block the degree of cooperation needed to resolve problems. Some issues obviously will never be resolved; but in some cases, a problem related to water supply may have to await solution while a more pressing problem is being resolved.

In some communities, weak leaders impede progress. The field worker will need time to help the water committee work with or around such leaders. Other problems include bad relations between the water committee and the rest of the community; conflicts with neighboring communities who use the water supply; failure to incorporate groups of the population, such as women and youth, into the process of participation; and finding a way to supervise specialized workers such as village health workers and village midwives. The single most important way for a field worker to sustain participation over the long-term is to keep a regular schedule of visits until the community achieves a certain level of autonomy.

### FAMILY FEUD DELAYS WATER PROJECT

In the Philippines, workers of the International Institute of Rural Reconstruction perceived in a certain rural community that it was no use to begin installing a hydraulic ram until the patriarchs of the two leading families had resolved their differences. It seems that they had been fast friends in their youth when they had played together in a string band but had become enemies in later years. However, both longed to see a string band organized in the village. The field worker helped organize a string band, asking both men to contribute. Within a year the band had won a prize. It was only then that the village council was able to reorganize, and the hydraulic ram project could move forward.

### 5.3 Determining the Proper Level of Community Financing of Construction, Operations, and Maintenance

Costs for the project (planning, construction, transport, user education, and operations and maintenance) can be shared by communities. Because of wide variations in income and in organizational capacity, it is difficult to insist that all water supply and sanitation projects be locally financed.

#### 5.3.1 Capital Costs

Capital costs for construction and/or installation of facilities are frequently borne mainly by the sponsoring agency, although in most CARE projects communities usually supply local materials (sand, gravel, and clay) and labor. For example, in the case of 73 gravity systems installed by CARE in three Indonesian provinces, the average pipeline length was 3,600 meters; one was 22,000 meters long. Agreeing to supply the amount of manual labor needed to lay such a long pipeline is a major commitment on the part of a community (see Illustration 9). In some instances, communities may bear some capital costs by buying cement, rebar, or even purchasing a pump. The cost of PVC pipe, however, in quantity sufficient for a gravity system would probably surpass the ability of communities to finance it. In practice, latrines are more often financed by householders or communities than are water supply installations. In any case, the sponsoring agency must frequently intervene in obtaining materials, especially cement, PVC pipe, and rebar, which are often difficult to obtain even if one has the money.

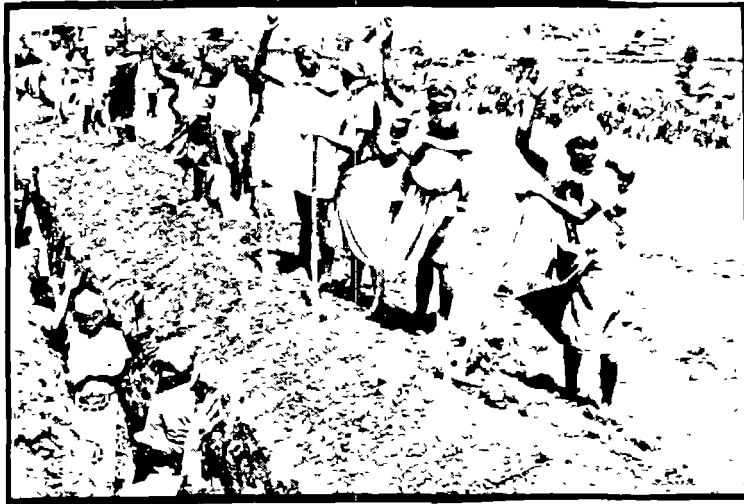

Illus. 9. Digging a trench for a gravity system. (Source: Mohamed Amin/Earthscan.)

### 5.3.2 Recurrent Costs

Recurrent costs are found in several categories:

- routine maintenance of installations
- replacement of lost, damaged, or stolen parts
- repair of installations when damaged or worn out
- salary for a local caretaker
- transport of parts and supplies to the community.

In the Togo Water Supply Project, these costs were estimated at about \$150 per year per village. Project planners should take the necessary steps to see that this money can be raised and used effectively. Suggested steps include:

- Making clear early in the project that there will be recurrent costs, estimating these costs, and emphasizing that the community will be at least partially responsible for them.
- Including ways for raising the money in plans the community makes to solve defined problems.
- Training the treasurer of the local committee in accounting and financial management.
- Inserting a line item in the project budget for starting up a village revolving fund.

### 5.3.3 Revolving Funds

Communities can set up revolving funds primed by the sponsoring agency from which materials can be purchased and which are subsequently replenished by periodic payments, user fees, or special financing efforts such as fairs, communal gardens, or sales of handmade articles. The same mechanism is useful in financing recurrent costs, which more frequently fall upon communities.

### 5.4 Designing Educational Efforts in Support of Community Participation

For the purposes of water supply and sanitation projects, user education may be considered as a combination of activities undertaken to achieve voluntary behavioral change with respect to the use and benefits of facilities. As for water supply, activities are focused on:

- use and abuse of the water supply
- maintenance of the improvement
- transport of water
- storage of water
- benefits of water supply
- links between water supply and health
- drainage (in crowded areas, this is sometimes a total village problem).

With respect to sanitation, the list of behavioral factors is long:

- use of a latrine for excreta disposal
- handwashing after defecation and before food preparation
- frequent bathing, especially of children
- improved food handling and storage
- handling children's fecal matter
- frequent clothes washing
- cleaning dishes and kitchen utensils
- protection against insect vectors
- keeping the house clean and in good repair
- keeping animals out of the house.

In a water supply and sanitation project, health education is a set of activities aimed at modifying behavior related to the subjects listed above. In most instances these activities will consist of group work, community organization, training, and the use of mass media.

In practice, given the important role of community participation, one should try to funnel most activities through the local committee. In fact, nothing should really be planned outside the committee. After an assessment of the behavior of community members, the committee should plan, with assistance from the field worker, a series of meetings of small groups and of the entire community. Target small groups might include the village council or leadership group, school officials, quarter or neighborhood associations, mothers in pre- or post-natal contact with local health workers, etc. In these meetings certain visual aids could be used to stimulate discussion, but the objective would be not merely to transmit information but to decide on a concrete plan of action. Certain community members could be trained as village-level health educators for the purpose of applying peer pressure on those for whom the group and community meetings are not effective. Other training would be technical, involving child-sized latrines, soap making, making mosquito nets, etc.

The mass media could be used to reinforce these local actions. Radio broadcasts, poster campaigns, and other mass media techniques can be employed; but they should be designed on the basis of local program needs.

Such a health education program closely tied to the community participation process is neither rapid nor easy, but neither is behavior change. There is no "magic bullet" for achieving desired changes in behavior.

### 5.5 Minimizing Maintenance Requirements

No water supply or sanitation installation is without requirements for maintenance, but certain steps can be taken to minimize those requirements. First is the choice of technology. A pump that must be lifted off its base to be repaired but is too heavy to lift without a vehicle is by definition an inappropriate technology. If the nuts on a pump can be turned only by a special wrench not found in a country, maintenance is impossible. Spare parts that are expensive for a village to buy or that are only in the store part of the time can jeopardize a maintenance program. Villagers in this case must spend excessive time collecting money or traveling to find parts. Before a technology is installed these issues should be addressed.

Second, a local organization can be formed to take charge of maintenance. The steps in forming this organization have been detailed earlier (Sections 5.2.3 and 5.2.4 and 8.2). Often, one or two caretakers for the facility are appointed from this group. Ideally, one of these persons would be a woman.

Third, this organization must be backed up by at least two tiers of a technical organization: the first, a local artisan (probably covering several villages) who can perform moderately difficult repairs and the second, a regional organization with technicians, vehicles, garages, and spare parts. The importance of this supportive backup cannot be underestimated.

Last, a local system for financing and purchasing spare parts, either totally or in part, must be developed. Money can be collected from each household or

can be raised from the sale of handicrafts or the products of a communal field.

If these steps are taken, maintenance will become a feasible procedure.

## 5.6 Designing a Sanitation Program

As sanitation measures that respond to problems raised in the village are identified, the following technical considerations should be taken into account:

### 5.6.1 Latrine Usage

When there is only one latrine per household, women are often the only users. In some societies this practice is based on the belief that the feces of men and women should not be mixed so as to avoid the sterilization of one or both parties. Even more basic is the belief that a woman's menstrual blood has a sterilizing effect on a man; and that when it is mixed with her stool or when it touches a man's stool in the latrine, the man can become sterile.

In other societies there is almost no interest in using latrines because of a preference for the "privacy" afforded by the "bush"; however, as the bush is disappearing under the pressure of increased cultivation, interest in using latrines is increasing. Often women and especially men prefer to defecate in the bush or in the forest while at work so as to avoid the inconvenience of walking back home to use a latrine. The unfortunate result is that this fecal material can be washed into surface water sources or shallow unprotected wells during a rain.

In addition, children aged two through four often do not use a family latrine either out of fear or because they have not been trained to do so. Children are afraid of the large hole, the darkness of the interior, and the distance from the house. At this age children fear falling into the latrine, possess a natural fear of dark enclosed places, and seek to avoid separation from parents and/or caretakers. As a result, small children frequently defecate indiscriminately around the house and yard until they learn adult defecation habits (see Illustration 10). In consequence, this frequently highly infectious fecal material contaminates the home environment with fecal pathogens.

The responsibility for keeping a latrine clean and the hole covered is borne primarily by women. (Even very simple latrines can be kept very clean, as shown in Illustration 11.) Particularly with simple pit latrines, the latrine must be cleaned daily and household members must be taught to defecate directly into the hole. Otherwise, the latrine becomes a foul-smelling, repulsive place that no one wants to use. Of course, the hole must be large enough if soilage of the edges is to be avoided, but not so large as to risk the danger of falling in. To avoid odors, it also is helpful to throw ashes into the pit



Illus. 10. Defecation practices of small children. (Source: Mark Edwards.)





Illus. 11. A well kept latrine in Burkina Faso. (Source: WASH Project.)

after each defecation. Thus, keeping a can of ashes in the latrine is recommended and using it systematically becomes part of everyone's responsibility. These measures are important in the control of ankylostomiasis (hookworm disease). Keeping the hole covered is also important in controlling Culex pipiens, the carrier of Bancroftian filariasis.

Women also are the primary (or sole) caretakers of young children and can influence the acceptance of sanitary habits around the home by example as well as by talking to their children. If they use a latrine regularly, many other members of the family might follow their example. In a very natural manner, this can lead to a widespread improvement in sanitation.

### 5.6.2 Personal Hygiene

Handwashing is one of the most important things to consider in terms of breaking the fecal-oral cycle since many enteric pathogens are transmitted by hands soiled by fecal matter. Hands should be washed just after defecation, but especially before the preparation or eating of food. Shigella transmission is particularly related to personal hygiene because this organism can be transmitted not only through food but also by objects touched by soiled hands (such as door knobs, kitchen utensils) or even by handshaking. It has been determined that washing with water alone is insufficient to break the Shigella transmission cycle. In a controlled experiment in Bangladesh, those participants using only water for handwashing had a much higher transmission rate than those washing with both water and soap. Other advisable aspects of personal hygiene include keeping nails short and bathing frequently.

Personal hygiene is, of course, the responsibility of every family member; but it is especially important for women because they handle nearly all the food consumed by the household. A study in Central America demonstrated that housewives had several more times the number of intestinal pathogens on their hands than did nurses working in a pediatric ward. The practice of personal hygiene is thus most important for women; but because ascariasis (an intestinal infection with nematode worms) is subject to auto-infection, handwashing should be practiced by everyone; and everyone should keep his or her fingernails short and clean.

### 5.6.3 Food Hygiene

The most important aspect of food hygiene is first to have clean hands before preparing food so as not to introduce intestinal pathogens into the food. For example, in Guatemala, it was shown that tortilla dough prepared early in the morning can become a vehicle for intestinal pathogens. The dough usually sits around until there are demands for tortillas, giving bacteria adequate time to multiply. The short time required for cooking the dough on the griddle is apparently not long enough to kill the bacteria.

Second, leftover food should be covered and, in the absence of refrigeration, not be kept without re-heating for more than 12 hours. Rowland et al showed that weaning foods were particularly susceptible to contamination when left too long. Contaminated food is probably the most important transmission vehicle for pathogenic E. coli, Shigellae, and Rotavirus, the three most important epidemiologic causes of diarrhea in infants and small children, and also of Ascaris (roundworm).

All the rules regarding the protection of food depend on women for their enforcement. They therefore are the most responsible for these sanitation measures.

#### 5.6.4 House Protection

The last sanitation measure to be mentioned is the protection of the house against the intrusion of passive carriers of enteric pathogens, principally flies. The home should be kept clean; uncovered food should not be left lying around; the feces of small children should be cleaned up immediately; and, if the family can afford it, screens should be put on doors and windows. Keeping the house free of food or fecal material lying around as an attraction for flies and other passive vectors of fecal pathogens is generally a woman's responsibility, but screening doors and windows to prevent flies and mosquitoes from entering depends entirely on the household economy.

All of the preceding measures require a considerable educational input focused especially on women. In keeping with the principle of channeling educational efforts through community level organizations, project planners should design educational programs as part of sanitation packets. Thus, if latrines were decided on to resolve the problem of intestinal worms, then the committee should plan not only the type of latrine, the financing of the slab, the obtaining of materials, and the construction but also the education of householders at every step.



## Chapter 6

### SELECTING THE MOST APPROPRIATE TECHNOLOGY

#### 6.1 Factors Influencing Technology Choice

In the development of a successful community-level water and sanitation project, certain characteristics of a locality and its people need to be observed, thought about, and understood. In some cases, common sense is all that is required; and in others, technical experience is a must. The challenge is to gather accurate information, understand interactions, and develop a project approach which has the greatest chance for success and flexibility. This section discusses one by one the factors that should be considered during technology selection.

##### 6.1.1 Physical Characteristics

The most obvious physical characteristic is the relative presence of water. This depends on the climate and the type of geologic formations in the area. Where water is plentiful, some assessment of water quality (bacteriological and chemical) may need to be made. This can usually be done by a person with training typically in environmental engineering, water chemistry, or epidemiology.

If water is scarce, the location of potential water sources and relative costs of source development must be determined. Locating the source of water can be very difficult. It may be done by a trained geologist, hydrologist or hydrogeologist, or in some cases an engineer (particularly civil) with assistance from people with intimate knowledge of the local geography. In order to accurately predict the relative costs of water source development, well drilling experience is usually a prerequisite. This is true since drilling costs can vary greatly by region and well depth.

From a sanitation point of view, soil type and depth to water table are very important. They help determine the range of feasible latrine designs. For example, the existence of hard clay soils may inhibit drainage of fluids from latrine pits. A high water table (usually within one to eight feet from ground surface) may preclude a traditional pit latrine and require a more expensive sealed, vaulted, or elevated facility.

Land slope is a physical characteristic which is important for the design of centralized potable water systems. It determines the location of centralized storage tanks and directly affects the cost of getting water from the water source (well, spring, stream, etc.) to either storage tanks or users.

The relative abundance or scarcity of sunshine, wind, or water may determine the feasibility of using alternative energy sources for water pumping. Increasing use is now being made of photovoltaics, or solar cells, for water-pumping. Where water is plentiful, hydro-rams may be used for raising water. Measuring the solar or wind resources available requires either the field

collection of meteorological data (usually for a minimum period of one year) or analysis of pre-existing data. Access to someone with training in meteorology or climatology and solar and wind monitoring equipment is necessary.

### 6.1.2 Human Settlement Patterns

Human settlement patterns refer to both the spatial distribution (or location) of households and the local land tenure situation. The existence of a tightly nucleated settlement usually augers well for the development of potable water systems by reducing the cost of construction per capita. (Less pipe required or greater number of people to share costs.) However, densely populated areas also may present difficulties for the development of sanitation options.

For example, depending on the type of soil, pit latrines should be placed anywhere from 15 to 30 meters either level or downhill from water sources. The presence of closely adjoining neighbors may make this difficult, thus requiring careful consideration of different sanitation alternatives and possibly the selection of a relatively "closed" system which is much more expensive (e.g., vault privies or septic systems).

Land tenure refers to access to and the right to use a piece of land. In areas where people rent, do not hold title to the land (are squatters), or are constantly on the move (nomads, refugees, or slash-and-burn agriculturalists), there is a natural inclination to avoid spending money on the land and, hence, on the construction or maintenance of water and sanitation facilities. A tenuous or unusual land tenure situation also makes it difficult to choose facilities (e.g., handpumps for nomads whose migration routes differ each year or season depending on rainfall patterns).

In order to gain an understanding of land tenure situations or human settlement questions, individuals with extensive local experience are invaluable. Backgrounds in human geography, regional planning, anthropology, political science, or sociology would be helpful as well.

### 6.1.3 Traditional Practices and Beliefs

There are too many examples of water and sanitation projects running amok because project designers had a poor or limited understanding of local traditions and beliefs. The dominant issue has often been the division of roles between males and females in many water and sanitation activities, such as drawing and carrying water, hygiene in the home and latrine, labor for construction activities, and general decision-making at either the household or village level. Sensitivity to these role divisions in the household is also extremely important for user education.

Traditional water and sanitation practices often dictate that either water or excreta be dealt with in very specific ways by certain people in the household. For example, in many cultures it is considered unwise to put water in closed containers. People believe that doing so does not allow the water to breathe and makes it unhealthy or unpalatable. From a sanitation viewpoint, the practice of "nightsoiling," which involves distributing human excreta on agricultural fields as fertilizer, is often encountered. The problem is that researching these beliefs and practices often falls to technicians who are from outside the region, many times from urban areas. Inappropriate technologies are selected, built, and then not used.

A philosophy of project design and implementation which incorporates extensive local input into the choice of the technologies will reduce the negative and increase the positive impacts of such practices or values and avoid serious pitfalls. Again, in this case, there is no substitute for extensive local experience in the villages. In the absence of such experience, an advisor with experience in cultural anthropology can be quite helpful in designing and implementing information gathering, processing, and problem-solving activities to address these issues.

#### 6.1.4 Past and Current Organizational Experience

In all areas there are unique ways in which villagers interact to make decisions and to manage local resources. How decisions are made will have a direct impact on how water and sanitation conditions may be improved. The institutional framework may be a village-, tribal- or neighborhood-level decision-making tradition; a national-, state- or regional-level political structure; or a familial custom governing the roles of each family member. Though projects may seek incremental changes in some of these institutional structures (e.g., less authoritarianism or decreased centralization), successful projects usually are the ones that acknowledge the existing system and capitalize on it where possible to achieve the project goals. In this context, project personnel will have to decide whether to work with existing organizations or form new ones. In doing so, it is critical to gauge who will take responsibility for long-term operations and maintenance. Even a relatively simple technology such as a handpump requires some long-term maintenance, the purchase of spare parts, and an organization able to carry out these activities.

#### 6.1.5 National Government Policies

Governments commonly establish national water and sanitation policies. These policies may cover areas such as water or sanitation system design, financing, operations and maintenance, community development, health education, or technology type. For example, some governments are now making the decision to standardize and, for example, use only UNICEF-certified India Mark II handpumps in their rural water supply programs (e.g., Belize). Another example is the use of WHO or UNICEF standards for handpumps per capita or volume of water

per capita. Governments may adopt and attempt to quickly meet these standards whether or not that is realistic. Another example is that a government may have a specific approach to what and how much villagers should contribute to the construction of a system (labor, materials, etc.). Project designers should investigate the existence of such policies, review their practicality, and address them during project design. Above all, the project should not blindly adopt unrealistic standards or fail to consider policies which may or may not be of benefit to the project. Flexibility should be sought so that the most cost-efficient and effective technology can be chosen.

#### 6.1.6 Current Economic Conditions

Project designers or programmers should emphasize the collection and analysis of recent and site-specific data on economic conditions. For example, national data which gives average income from agriculture may be way off if during a particular year there is drought or if the price for an agricultural product is drastically reduced. This will have a direct and immediate impact on the ability of the population to invest in water and sanitation facilities.

#### 6.1.7 Access to Technical Expertise and Project Materials

As already noted, certain critical materials or technicians must be present at particular stages of any project in order for design or implementation to proceed. In water projects, lead well drillers; handpump mechanics or local village leaders; and materials, such as well drilling rigs and/or well casing, drill bits, cement, or handpumps, are often critical. Once a water supply project is built, a constant factor will be the availability of spare parts; a qualified repair technician; and, where motorized pumps are used, fuel. In sanitation projects, the indispensable actors are usually a village leader and a sanitation (usually latrine) construction advisor and materials such as cement and good construction sand.

#### 6.1.8 Emergency Situations

Often a particularly dire public health situation will require immediate assistance in very practical activities, such as well drilling, handpump or basic sanitation facilities installation, and water storage or water treatment. The U.N. High Commissioner on Refugees (UNHCR), the WASH Project, and other similar organizations are constantly responding to situations such as these. UNHCR has developed agency guidelines for dealing with such situations (UNHCR Handbook for Emergencies: Field Operations). When there are outbreaks of diseases such as cholera, typhus, or malaria, drastic measures may be necessary to control the situation.



A complicating factor in emergency situations is that while immediate solutions are necessary, implementing them may undermine the widely advocated long-term "bottom-up" approach to development. For example, sanitation needs may require immediate placement of portable latrines by outside technicians. In this case, the technology selected is clearly a compromise, both technologically and from a development perspective. Also complicating the situation is the likelihood that a temporary refugee settlement will probably become a permanent one. In this context, health education assumes a crucial role. Refugees or residents must understand why certain actions have taken place, why temporary solutions have been used and what ultimate goals should be in terms of water and sanitation conditions.

## 6.2 Methods for Selecting a Technical Approach

Almost every technical approach is a compromise between the best technological solution and the availability of resources and general conditions at the project site. The challenge is to select the approach most likely to succeed. It should be flexible and closely matched to the needs and desires of those who will use it.

As mentioned in Chapter 3, baseline information gathered from primary and secondary sources forms the basis for decisions about a project's technical approach. On-site data are particularly important. The use of baseline surveys is one method which allows a project staff to determine water and sanitation conditions at the household level and criteria by which to select technologies. Such surveys should be designed and pretested with assistance from village residents.

Another aspect of technology selection is a process of elimination. In this process, the reason(s) for previous project failures is determined. The important part of this exercise is to establish which factor was the major cause of a program's success or failure--was it a specific technology, or the way a technology was used? The cause for failure could be something inherent in the project or an external, uncontrollable event. Almost every project has good elements that can be "cannibalized" for future use and/or bad components which should never be used again.

A third method for technology selection is cost-benefit analysis, which can be used to weigh the advantages and disadvantages of one or many different project alternatives from the perspective of financial costs. There is extensive information available about this technique and many guides to help project personnel carry out such an analysis. However, an individual with training in economics and/or experience in cost-benefit analysis should be sought when undertaking a cost-benefit analysis.

### 6.3 Water Supply Technology Options

In this and the following section, a short review of various technology options is provided. This document cannot provide comprehensive and detailed coverage of each technology. Rather, each option's applicability is discussed and sources of more detailed information are given. The emphasis is on describing key factors which limit the use of a technology in certain situations.

#### SELECTED REFERENCES ON TECHNOLOGY OPTIONS

Cairncross and Feachem. Small Water Supplies.

Darrow, Keller and Pam. Appropriate Technology Source Books, Volumes I and II.

IRC. Practical Solutions in Drinking Water Supply and Wastes Disposal for Developing Countries.

Further useful references are cited in the Annotated Bibliography at the end of this volume.

Water can be obtained either from surface or subsurface (groundwater) sources. Surface water sources include rivers, lakes, springs, rainwater catchments, or manmade reservoirs. The advantage of surface water is that it is easily accessible--the disadvantage is that it is easily contaminated. Subsurface sources usually are underground streams, springs, or aquifers which are tapped through either dug or drilled wells. Although access to subsurface water is more difficult and often more costly, the quality of water is usually better. Technological options for water supply are as follows:

- gravity-flow water systems
- spring-caps
- rainwater catchment systems (cisterns)
- machine-drilled wells
- hand-dug or augered wells
- pumping systems powered by animals, hand, wind, sun (photovoltaics), hydraulic rams, and diesel or gasoline engines.

### 6.3.1 Gravity-Flow Systems

Gravity-flow water systems distribute water from any source (spring, well, rainwater catchment) to standpipes or households via a piped system (see Illustrations 12 and 13). Gravity, not a machine or engine, forces the water through the pipes. Elements of the system include source development (well-drilling, spring capping, etc.), a water tank for storage, and a distribution system (pipes, faucets, etc.). A pump is often required to get the water from the source to the storage unit. The storage unit may be above ground (elevated tank) or on the ground at the highest elevation in the town. Careful sizing of the pump, the storage tank, and the pipes in the distribution system is usually required. This type of system is usually more cost-effective in areas where population density is high since it requires even greater investment in the development of a local community system for construction, operations, and maintenance, which can be very problematic or time-consuming.

#### MORE ABOUT GRAVITY SYSTEMS

Relevant Organizational Experience: CARE, UNICEF, Peace Corps, USAID, and the World Bank all have extensive experience with these systems.

#### Good Technical Documents

Hofkes. Small Community Water Systems--Technology of Small Water Supply Systems in Developing Countries.

UNICEF. Handbook of Gravity-Flow Water Systems for Small Communities.

VITA. Using Water Resources.

See Annotated Bibliography for full citations.

### 6.3.2 Capped Springs

Spring-capping is often one of the most cost-effective ways of developing a water source where free-flowing springs are present (see Illustration 14). Spring-capping can be done many different ways. A reservoir for storage can be built, animals can be fenced out of the spring area, and drainage ditches can be dug to minimize standing water. With springs, they must produce enough water for local needs year-round and, if possible, the water must not be contaminated with bacteria or other pollutants. Expensive machinery is not usually required to build capped springs -- usually masonry skills will suffice.



Illus. 12. A gravity system being installed. (Source: WHO, Photo by J. Abcede.)



Illus. 13. Standpipe. (Source: UNICEF)



Illus. 14. A capped spring in a UNICEF project in Burundi.  
(Source: WASH Project.)

## MORE ABOUT SPRING CAPPING

Relevant Organizational Experience: Peace Corps, CARE, UNICEF, and USAID all have experience working with springs.

### A Good Technical Document

Hofkes. Small Community Water Systems--Technology of Small Water Supply Systems in Developing Countries, Chapter 6.

### 6.3.3 Rainwater Catchment

Rainwater catchments are commonly found in areas where groundwater is very deep and inaccessible and/or the surface water that is available is contaminated (salt, bacteria, hydrogen sulfide, etc.). Unless great care is taken with the cleaning of the rainwater collection unit and the storage tank, rainwater catchments often provide water of poor quality. The typical collection unit is the roof of a building (see Illustration 15). Storage tanks can be made of concrete, ferrocement, metal, or wood. If the water is to be used for drinking, the storage tank should be drained regularly and, preferably, treated with a chemical agent such as chlorine. Usually, a rainwater catchment system is proposed only when there is no other alternative or as a supplement to other systems.



Illus. 15. A rainwater catchment system in a hospital in Zaire. The gutter is just over the doorway. The tank is attached to a diesel pump system. (Source: WASH Project.)

#### MORE ABOUT RAINWATER CATCHMENT

Relevant Organizational Experience: Peace Corps, CARE, UNICEF, and USAID all have experience with these systems. Many missionary groups have also used them.

#### Good Technical Documents

Hofkes. Small Community Water Systems--Technology of Small Water Supply Systems in Developing Countries, Chapter 5.

UNEP. Rain and Stormwater Harvesting for Additional Water Supply in Rural Areas.

World Bank. Harvesting Precipitation for Community Water Supply.

#### 6.3.4 Machine-Drilled Wells

Machine-drilled wells are usually drilled with a large percussion- (cable tool) or rotary-type well-drilling rig (see Illustration 16). Although

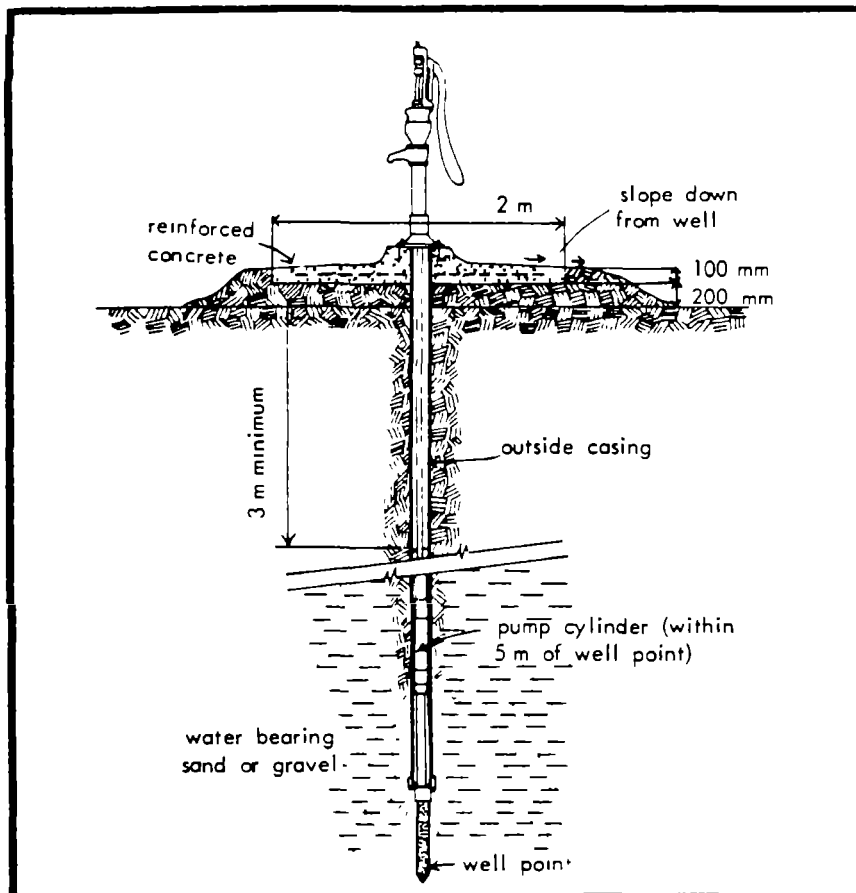

Illus. 16. A tube well with a driven well point. (Source: Cairncross and Feachem, Small Water Supplies.)



portable drilling rigs exist--they can be carried on a horse or donkey--they are usually only durable enough to drill between two and ten wells. Larger rigs which require a two- to four-person team of trained well drillers are used more often. Most projects use and can depend on these types of rigs, which are good for any well depth. Depending on the geology in the project area, a choice must be made between rotary- and percussion-type rigs. Drill rig selection should be made very carefully and in consultation with experienced drillers. More than one opinion should always be sought. Potential well siting is crucial because mistakes in drilling can be costly.

#### MORE ABOUT WELL DRILLING

Relevant Organizational Experience: CARE, UNICEF, and USAID all have extensive project histories with different drilling systems. UNICEF is currently reviewing the best uses and state-of-the-art technology for portable drill rigs. WASH has extensive background information on different approaches. Contact Jim Jordan, Operations and Maintenance Specialist, at the WASH Project. A knowledgeable contact at CARE is Alfred Lambertus of CARE/Indonesia.

#### Good Technical Documents

Brush. Well Construction--Hand Dug and Hand Drilled.

Campbell and Lehr. Water Well Technology.

National Well Association. Appropriate Well Drilling Technologies: A Manual for Developing Countries. (For USAID's Office of Health.)

See Annotated Bibliography for full citations.

#### 6.3.5 Hand-Dug Wells

Wells dug by hand with shovels or augers are one of the most common existing sources of water in most countries (see Illustration 17). If it is adequately protected (i.e., covered, interior walls sealed with plaster, proper drainage away from top of well, no standing water), a hand-dug well can be a good water source. However, many such wells are left unprotected and open to contamination (see Illustration 18). Many projects have focused on rehabilitating these wells, particularly by putting covers and handpumps on them. Few hand-dug wells are more than 100 meters deep, and most are between 5 and 15 meters.



Illus. 17. A hand augured well. (Source: Blankwaardt. Hand Drilled Wells: A Manual on Siting, Design, Construction and Maintenance. Rwegarulila Water Resources Institute, Dar Es Salaam, Tanzania, 1984.)



Illus. 18. An open dug well subject to contamination. (Source: UNICEF.)

#### MORE ABOUT HAND-DUG WELLS

Relevant Organizational Experience: Peace Corps, CARE, UNICEF, and USAID all have a great deal of experience with this practice. The WASH Project has numerous publications on different methods. Contact Dan Campbell, librarian, at the WASH Project. A knowledgeable contact at CARE is Mr. Mulyanto of CARE/Indonesia.

#### A Good Technical Document

VITA. Using Water Resources.

#### 6.3.6 Handpumps

Handpumps are the most commonly used technology for drawing water. A distinction should be made between deep- (over 10 meters) and shallow-well (under 10 meters) handpumps. They can be locally manufactured in some cases, although this requires years of design and manufacturing work. The most popular makes are India Mark II, Dempster (made in the United States), and Moyno. Over the past 10 years, an attempt has been made to develop handpumps which can be maintained by village-level technicians. Many countries are standardizing--that is, using one brand of handpump for all projects (usually the India Mark II).

#### MORE ABOUT HANDPUMPS

Relevant Organizational Experience: CARE, UNICEF, and USAID have extensive experience procuring, installing, and maintaining handpumps for water supply programs. During the past six years, the World Bank has completed a series of technical evaluations of different handpumps. USAID and UNDP have extensive project experience in the local manufacture of handpumps, with varying results.

#### Good Technical Documents

World Bank. Rural Water Supply Handpumps Project: Handpumps Testing and Development: Progress Report on Field and Laboratory Testing.

### 6.3.7 Animal Traction Pumps

Animal traction pumps have been used successfully for many years in some areas of the developing world. While most types are not very high in efficiency, they are normally manufactured (and therefore maintainable) locally so that they provide relatively reliable service. They usually require extensive user participation and cooperation to manage the animals. Designs range in increasing complexity from simple rope, bucket, and pulley systems (such as the Indian "mohte") to a series of buckets on a chain driven by a turning wheel (the Persian wheel) to the Egyptian "sakia" (a double-sided, metal wheel with volute-shaped compartments which scoop water up and funnel it to a central opening around the axis to more complex (and expensive) units such as a six-donkey powered unit driving a 700:1 gearbox attached to a standard high speed rotary pump (under development in Botswana).

The cost, performance, and social acceptance of animal-drawn pumps is very country- and site-specific. Cost competitiveness with other pumping options depends on:

- local labor cost (animal-drawn pumps normally require one to three laborers to manage the animals)
- whether or not draft animals are in common use in the area
- ownership of the animals
- whether users already own animals (used for other purposes, such as plowing)
- age, size, and physical condition of the animals
- availability and cost of forage or feed
- alternative demands on animals' time (such as plowing) when water is required.

While some preliminary work has been done in several countries, extensive testing of the wide variety of animal-drawn pumps has not yielded firm results. Generally, single animals can deliver approximately 200 to 300 watts to the pumping mechanism. Multiple-animal pumps are less efficient of each animal's power (i.e., two animals deliver 350 to 500 watts). Typical outputs for various animal-powered pumps (assuming two bullocks and a five meter total head) are:

- rope and bucket: 10-15 m<sup>3</sup>/hr
- Persian wheel: 16 m<sup>3</sup>/hr
- chain and washer pump: 15-20 m<sup>3</sup>/hr

### MORE ABOUT ANIMAL-DRIVEN PUMPS

#### Relevant Organizational Experience

Some work has been done on the development of higher-efficiency animal-powered pumps in Egypt (the USAID-funded Egyptian Water Use and Management Project), India (at the Punjab Agricultural University), and Botswana (at the Rural Industries Innovation Centre). Much of this work involves using metal instead of traditionally wooden pump components (such as bearing surfaces), which increase the cost of the pump. The Intermediate Technology Development Group (ITDG) has done a brief survey of the field as preliminary work for the development of upcoming field projects.

#### Good Technical Documents (in decreasing order of complexity)

Egypt Water Use and Management Project. A Technical and Economic Analysis of Low-Lift Irrigation Pumping in Egypt.

Frankel. FAO Irrigation and Drainage Paper: Prime Movers and Pumps for Small-Scale Lift Irrigation FAO.

Kennedy and Rodgers. Human and Animal-Powered Water-Lifting Devices. (ITDG).

#### 6.3.8 Wind-Powered Pumps

Wind-powered water pumps are of two kinds: those which directly drive a mechanical water pump (normally a reciprocating piston or some type of rotary pump) and those which use a wind turbine to generate electricity which then drives a standard electric pump. The vast majority of experience with wind pumps has been with the direct-drive mechanical types. Up until quite recently, the technology had not been improved upon since the 1930s. There are several new types of both low- and high-cost wind pumps under development which merit attention. Their primary advantages include low maintenance requirements and zero fuel costs (when back-up systems are not required). Their primary disadvantage is that they are limited to sites which have sufficiently high year-round wind speeds.

Some knowledge of the magnitude of the wind resource at the prospective site is necessary before considering the appropriateness of a wind pump. Assuming that water demand is fairly constant throughout the year, the wind must also be available year-round. If it is not, then a back-up system such as an auxiliary diesel should be considered to meet peak demands when wind is not available. Generally speaking, if the average annual wind speed at the site is less than four meters per second, or pumping heads are greater than 60 meters, wind pumps should not be considered an economically viable alternative to

diesel pumps. This assumes that diesel fuel, spare parts, and trained mechanics are available to service the equipment.

Windmills are sized by the diameter of the rotor or blades. Sizes range from approximately 1.8 meters to 7.3 meters in diameter. Costs vary considerably but range from \$2,300 for the 1.8-meter size to over \$11,000 for the 7.3-meter size (respectively, \$<sup>2</sup> and \$262/m<sup>2</sup>, including tower costs). At typical operating efficiencies, the smaller machine delivers approximately 0.05 horsepower (Hp), or 39 watts; and the larger, 0.74 Hp, or 550 watts, in an average daily wind speed of four meters/second.

#### MORE ABOUT WIND-POWERED PUMPS

Relevant Organizational Experience: Although several donor organizations have contributed significantly to the extensive ongoing research on water pumping with windmills, much of the actual expertise resides with consulting firms which are technical assistance contractors to the donor agencies. Organizations which have experience in wind pumping include (but are not limited to) CWD (Dutch), Intermediate Technology Power (UK), Associates in Rural Development, and Research Triangle Institute (U.S. through the WASH Project). Considerable expertise is also available in the academic community and several U.S. government organizations, such as the Department of Energy Wind Program in Colorado, and USDA research centers.

#### Good Technical Documents (in decreasing order of complexity)

Lysen. Introduction to Wind Energy.

IT Power. Wind Technology Assessment Study. Vol. 1 Wind Study Report.

Hodgkin and McGowan. Wind Pump Field Tests in Botswana-- Preliminary Technical and Cost comparisons

Park. The Wind Power Book.

Hirshberg. The New Alchemy Water Pumping Windmill Book.

#### 6.3.9 Solar-Powered Pumps

Photovoltaic (PV) cells directly convert sunlight to electricity. PV reliability has risen and the cost of PV pumps has dropped dramatically in the last five years and will likely continue to do so, although probably not at as rapid a rate as has been experienced thus far. Their principal advantages

include very high reliability of the power modules, very low recurrent costs for operation and maintenance, and zero fuel costs. The principal disadvantage is the high initial capital cost of the equipment.

Some knowledge of the magnitude of the solar energy resource at the prospective pumping site is necessary before considering using a PV pump since the cost of the system is inversely proportional to the average solar radiation level. Assuming that water demand is fairly constant throughout the year, sufficient solar radiation must also be available on a year-round basis. If it is not, then a back-up system such as an auxiliary diesel should be considered to meet peak demands when sufficient solar radiation is not available. PV manufacturers will provide all necessary design expertise as part of the purchase price of the system.

Commercially available PV pumps are in the 0.5 to 3.0 Hp range. Much larger systems (25 Hp) are in operation but should be considered experimental prototypes at present. PV pumps should be considered only for sites where annual average solar radiation levels are greater than 15 MJ/m<sup>2</sup>/day (megajoules per square meter per day, i.e., less than in the Sahara Desert but more than in the northern United States), where pumping heads are less than 60 meters, and where average annual wind speeds are less than four meters/

#### MORE ABOUT SOLAR-POWERED PUMPS

Relevant Organizational Experience: Although several donor organizations have contributed significantly to the extensive and ongoing research on water pumping with PV, much of the actual expertise resides in consulting firms which are technical assistance contractors to the donor agencies. Organizations which have experience in PV pumping include (but are not limited to) Intermediate Technology Power (UK) and Associates in Rural Development (U.S.). Considerable expertise is also available in the academic community and several U.S. government organizations, such as the Department of Energy Photo-voltaics Program.

Good Technical Documents (in decreasing order of complexity)

Halcrow and I.T. Power. Small-Scale Solar-Powered Pumping Systems, the Technology, Its Economics and Advancement.

McGowan and Hodgkin. Solar Pump Field Tests in Botswana-- Preliminary Technical and Cost Comparisons.

Kenna and Gillett. Solar Water Pumping.

McGowan. Current Developments in PV Irrigation in the Developing World.

second. Where wind speeds are greater than four meters/second, wind pumps should be investigated. PV pumps cost approximately \$7,300/Hp of rated output of the power modules (\$9.80 per peak watt).

#### 6.3.10 Hydraulic Rams

Hydraulic rams use the force of water flowing from a higher elevation as their source of energy. They are used for pumping water from mountain streams or from pipes coming from a reservoir at a high altitude. They cannot be used for pumping water from a well. They are applicable only where there is a considerable elevation change and a large amount of steadily flowing water. Hydraulic rams have been installed in areas such as Nepal. Advantages are that they require no external power source, are simple to make, and have only two moving parts.

##### MORE ABOUT HYDRAULIC RAMS

Relevant Organizational Experience: Peace Corps has conducted numerous technical training programs and field projects which have utilized the hydraulic ram. Because the system requires a lot of water and elevation change, it is not widely used in many developing countries by projects at USAID or the World Bank.

##### Good Technical Documents

Hofkes. Small Community Water Systems--Technology of Small Water Supply Systems in Developing Countries.

U.S. Peace Corps. Hydrams: A Training Manual.

#### 6.3.11 Diesel- and Gasoline-Powered Pumps

Diesels are by far the most common power source for stand-alone water pumping at remote sites. Since gasoline is normally more expensive than diesel fuel and since gasoline engines are not generally available in a wide range of sizes in much of the developing world, these remarks will be confined to diesel-powered engines. A mature technology, diesel pumps have the following advantages: nearly universal availability; low initial capital cost; independence from the vagaries of site-dependent energy resources (such as wind or solar radiation); a wide range of capacities (except in the <3-Hp range for the smallest water systems), which allow for sizing medium to large



systems to meet site-specific needs; and a long lifetime when properly maintained.

They also have many disadvantages. They must be frequently maintained; and if they are not, their performance can be seriously degraded and their lifetime shortened. Skilled labor is needed to perform maintenance procedures. The fuel is expensive, subject to inflationary increases in price, and sometimes short in supply; and required spare parts are often unavailable. Where grid electric power is unavailable or its supply unacceptably unreliable, diesel engines for pumping should be considered as the prime alternative for medium to large systems.<sup>2</sup> However, the following conditions must be met:

- The diesel fuel supply must be available and reliable.
- Skilled labor must be available for regularly scheduled maintenance.
- Diesel fuel costs must not be inflating rapidly and/or subsidized to reduce consumer costs.
- Initial capital costs must be seen as a more critical criterion for choice of system than long-term recurrent costs (see wind, PV, etc.).
- Water demands and well constraints require either medium to high flows (>2 liters/sec) or low flows at high pumping heads (deep wells or high storage tanks).

---

<sup>2</sup>The size of a system is a function of the volume of water pumped times the pumping head (roughly, the height lifted). The result is called the volume head product. A rule of thumb definition of system sizes follows: small-size system - < 50m<sup>3</sup>/day at 50m pumping head or < 2,500 m<sup>3</sup>\*m/day; medium-sized system - 50-100m<sup>3</sup>/day at 50-100m pumping head or 2,500 -10,000m<sup>3</sup>\*m/day; large system > 100m<sup>3</sup>/day at 100m+ pumping head or > 10,000m<sup>3</sup>\*m. These figures are illustrative approximations only. A large system could also be defined, for instance, as 1,000 m<sup>3</sup>/day at 10m pumping head because it meets the volume head product criterion for a large system.

## MORE ABOUT DIESEL PUMPING

Relevant Organizational Experience: Other than manufacturers' literature on the output, fuel consumption, and equipment costs of diesel pumping, surprisingly little data have been gathered on the actual long-term performance and costs of pumping water with diesels. Since long-term recurrent costs represent the primary component of life-cycle costs, this is an unfortunate omission in the literature. One study has been done of long-term costs covering the performance of more than a thousand diesel systems in Kenya, but it has not yet been published.

### A Good Technical Document

Fraenkel. The Power Guide: A Catalogue of Small-Scale Power Equipment.

McGowan and Hodgkin. Water Pump Field Tests in Botswana.

## 6.4 Sanitation Technology Options

Technological options for sanitation include:

- composting toilets
- vault, "soakaway," and water-seal privies
- septic tanks and flush toilets
- sewered sanitation systems
- bucket latrines
- pit latrines
- showers
- washing slabs
- dish washing racks
- drainage.

Sanitation systems can be classified as either "wet" or "dry." Illustrations 19-22 show various latrine options. Wet systems use water to carry the excreta to a pit or drainage unit (e.g., septic tank or vault). They are usually more expensive to build as they require more extensive design and construction work and more materials (cement and sand). Dry units are the predominant excreta disposal system for most developing countries. They include the basic pit latrine, the ventilated improved pit latrine (VIP), or the Reed Odorless Earth Closet (ROEC). Table 1 at the end of this chapter provides a short descriptive

comparison of sanitation technologies (prepared by the World Bank). Absent from the chart is the ubiquitous basic pit latrine. It is an important option to be considered in any region where sanitation practices (in particular excreta disposal) are at the most basic level. Table 2 provides a list of critical information needs for selecting a sanitation technology.

#### MORE ABOUT LATRINES

Relevant Organizational Experience: CARE, UNICEF, and USAID (and for that matter, many other agencies) have extensive experience working with the basic pit latrine, VIP latrines, and pour-flush toilets. Because of the high cost and limited applicability in rural areas, CARE has more limited experience with most of the wet latrine or sanitation options and the ROEC. The World Bank and USAID have funded many urban water and sanitation projects which have provided them with more experience in relevant technologies, including septic tanks, sewer flush toilets, and aquaprivies.

#### Good Technical Documents

Cairncross and Feachem. Small Excreta Disposal Systems.

Kalbermatten et al. Appropriate Technology for Water Supply and Sanitation, A Planner's Guide.

Rybczynski, Polprasert, and McGarry. Low-Cost Technology Options for Sanitation, A State-of-the-Art Review and Annotated Bibliography.

Table 1

## The Excreta Disposal Aspect of Sanitation Technologies Compared:

ANALYSIS OF FIELD STUDY RESULTS

TECHNICAL AND ENVIRONMENTAL ASSESSMENT

Sanitation technology	Rural application	Urban application	Construction cost	Operating cost	Ease of construction	Self help potential	Water requirement	Required soil conditions	Complementary off site investment <sup>a</sup>	Reuse potential	Health benefits	Institutional requirements
VIPS and ROFCS	Suitable	Suitable in L/M-density areas	L	L	Very easy except in wet or rocky ground	H	None	Stable permeable soil groundwater at least 1 meter below surface <sup>b</sup>	None	L	Good	L
PF toilets	Suitable	Suitable in L/M-density areas	L	L	Easy	H	Water near toilet	Stable permeable soil groundwater at least 1 meter below surface <sup>b</sup>	None	L	Very good	L
DVC (double vault composting) toilets	Suitable	Suitable in L/M-density areas	M	L	Very easy except in wet or rocky ground	H	None	None (can be built above ground)	None	H	Good	L
Self topping aquaprivy	Suitable	Suitable in L/M-density areas	M	L	Requires some skilled labor	H	Water near toilet	Permeable soil groundwater at least 1 meter below surface <sup>b</sup>	Treatment facilities for sludge	M	Very good	L
Septic tank	Suitable for rural institutions	Suitable in L/M-density areas	H	H	Requires some skilled labor	L	Water piped to house and toilet	Permeable soil groundwater at least 1 meter below surface <sup>b</sup>	Off site treatment facilities for sludge	M	Very good	L
Three-stage septic tanks	Suitable	Suitable in L/M-density areas	M	L	Requires some skilled labor	H	Water near toilet	Permeable soil groundwater at least 1 meter below surface <sup>b</sup>	Treatment facilities for sludge	M	Very good	L
Vault toilets and cartage	Not suitable	Suitable	M	H	Requires some skilled labor	H (for vault construction)	Water near toilet	None (can be built above ground)	Treatment facilities for night soil	H	Very good	VH
Sewered PF toilets, septic tanks aquaprivies	Not suitable	Suitable	H	M	Requires skilled engineer/builder	L	Water piped to house and toilet	None	Sewers and treatment facilities	H	Very good	H
Sewerage	Not suitable	Suitable	H	H	Requires skilled engineer/builder	L	Water piped to house and toilet	None	Sewers and treatment facilities	H	Very good	H

Note: L, low; M, medium; H, high; VH, very high

a On- or off site sullage disposal facilities are required for nonsewered technologies with water service levels in excess of 50 to 100 lpd depending on population density

b If groundwater is less than 1 meter below the surface a plinth can be built

TABLE 2

CRITICAL INFORMATION NEEDED FOR SELECTION AND  
DESIGN OF SANITATION SYSTEMS

Climatic conditions

temperature ranges; precipitation, including drought or flood periods

Site conditions

topography  
geology, including soil stability  
hydrogeology, including seasonal water-table fluctuations  
vulnerability to flooding

Population

number, present and projected  
density, including growth patterns  
housing types, including occupancy rates and tenure patterns  
health status of all age groups  
income levels  
locally available skills (managerial and technical)  
locally available materials and components  
municipal services available, including roads, power

Environmental sanitation

existing water supply service levels, including accessibility and reliability,  
and costs  
marginal costs of improvements to water supply  
existing excreta disposal, sullage removal, and storm drainage facilities  
other environmental problems such as garbage or animal wastes

Socio-cultural factors

people's perceptions of the present situation and interest in or susceptibility  
to change  
reasons for acceptance/rejection of any previous attempts at upgrading  
level of hygiene education  
religious or cultural factors affecting hygiene practices and technology  
choice  
location or use of facilities by both sexes and all age groups  
attitudes toward resource reclamation  
attitudes toward communal or shared facilities

Institutional framework

allocation of responsibility and effectiveness of state, local, or municipal  
institutions in providing the following services:  
water  
sewerage, sanitation, street cleaning, drainage  
health  
education  
housing and urban upgrading

NOTE: The priority of various items will vary with the sanitation options being  
considered; the list above indicates typical areas which should be  
investigated by planners and designers.

**Conventional Unimproved Pit Latrines  
(millimeters)**

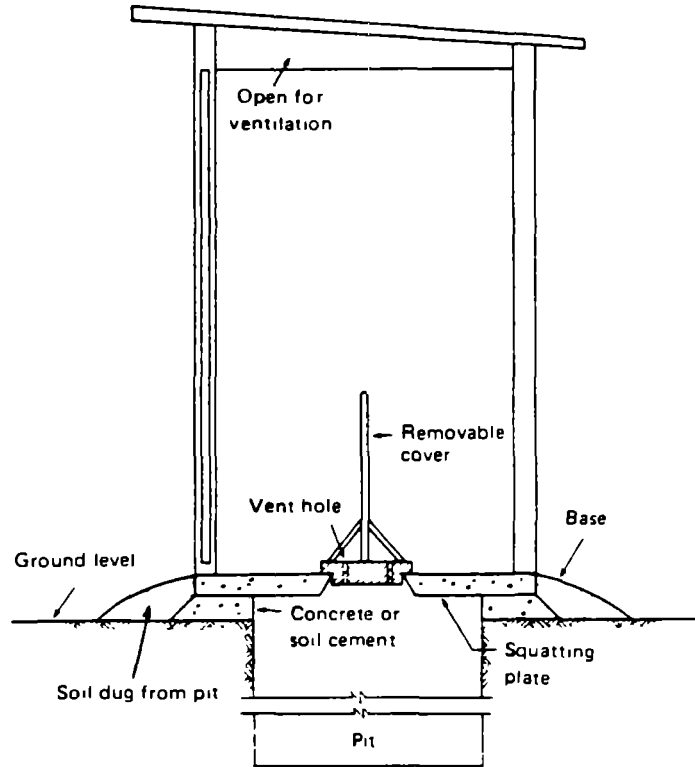

**Side view**

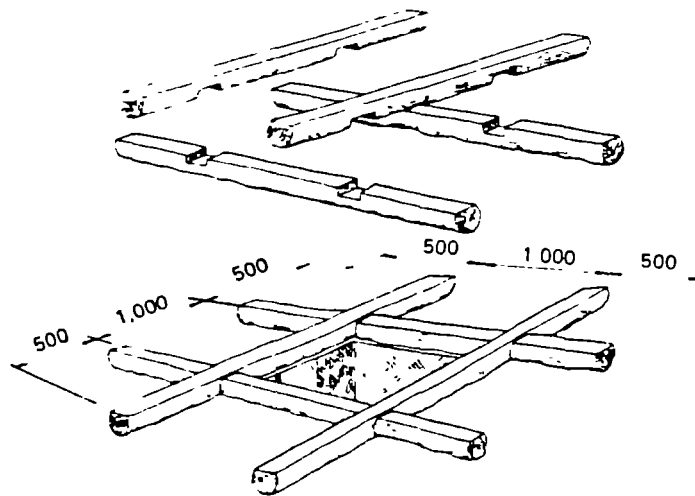

**Alternative base using hewn logs**

**Note:** In termite-infested areas use treated wood or termite barrier

Illus. 19. Conventional unimproved pit latrine. (Source: Kalbermatten, et al., Appropriate Technology for Water Supply and Sanitation.)

## Ventilated Improved Pit Latrine (measurements in millimeters)

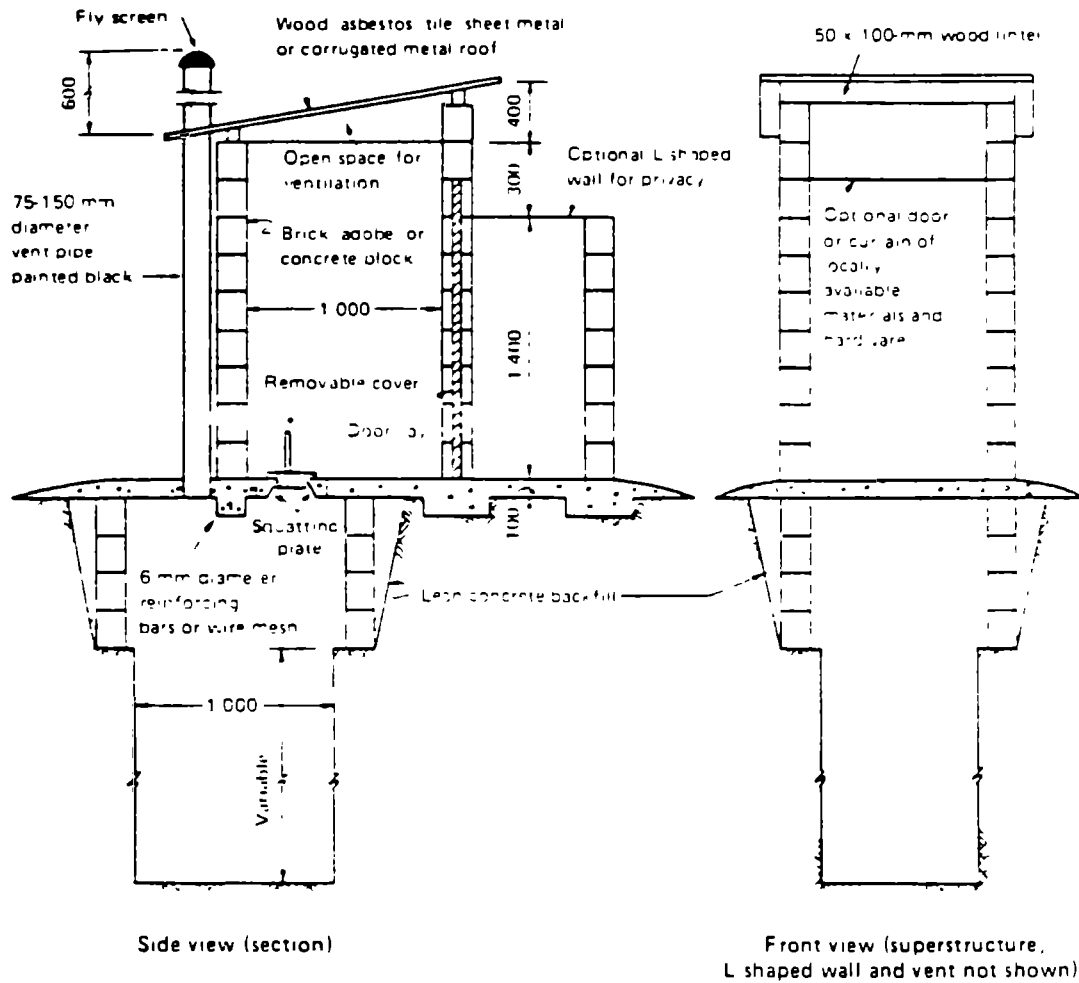

Note: Side view. Pedestal seat or bench may be substituted for squatting plate. An opening for desludging may be provided next to vent. Dimensions of the bricks or concrete blocks may vary according to local practice. Wooden beams, flooring and siding may be substituted for concrete block walls and substructure.

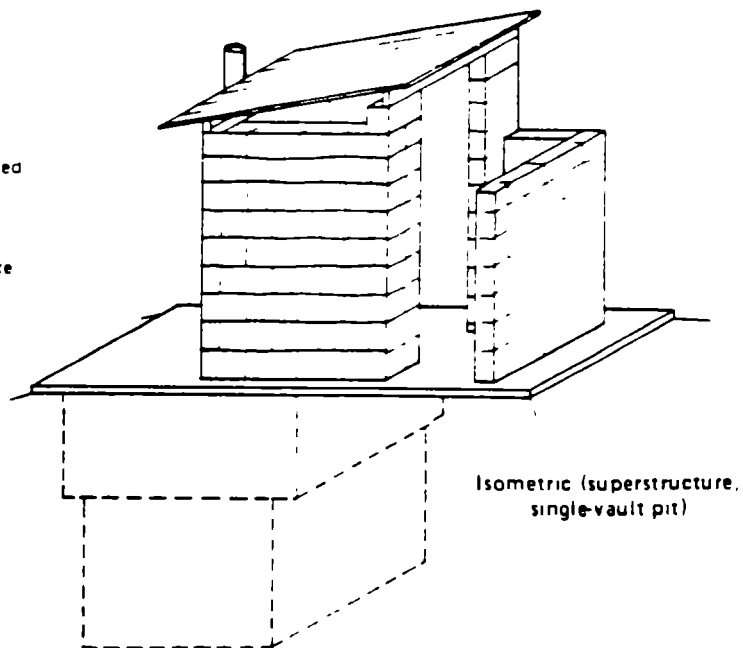

Illus. 20. Ventilated improved pit latrine (VIP). (Source: Kalbermatten, et al., Appropriate Technology for Water Supply and Sanitation.)

(millimeters)

A. Plan

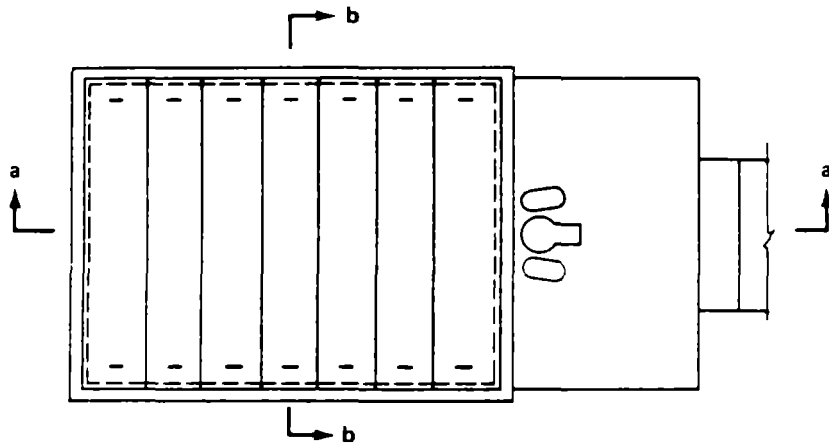

Plan (with latrine superstructure removed)

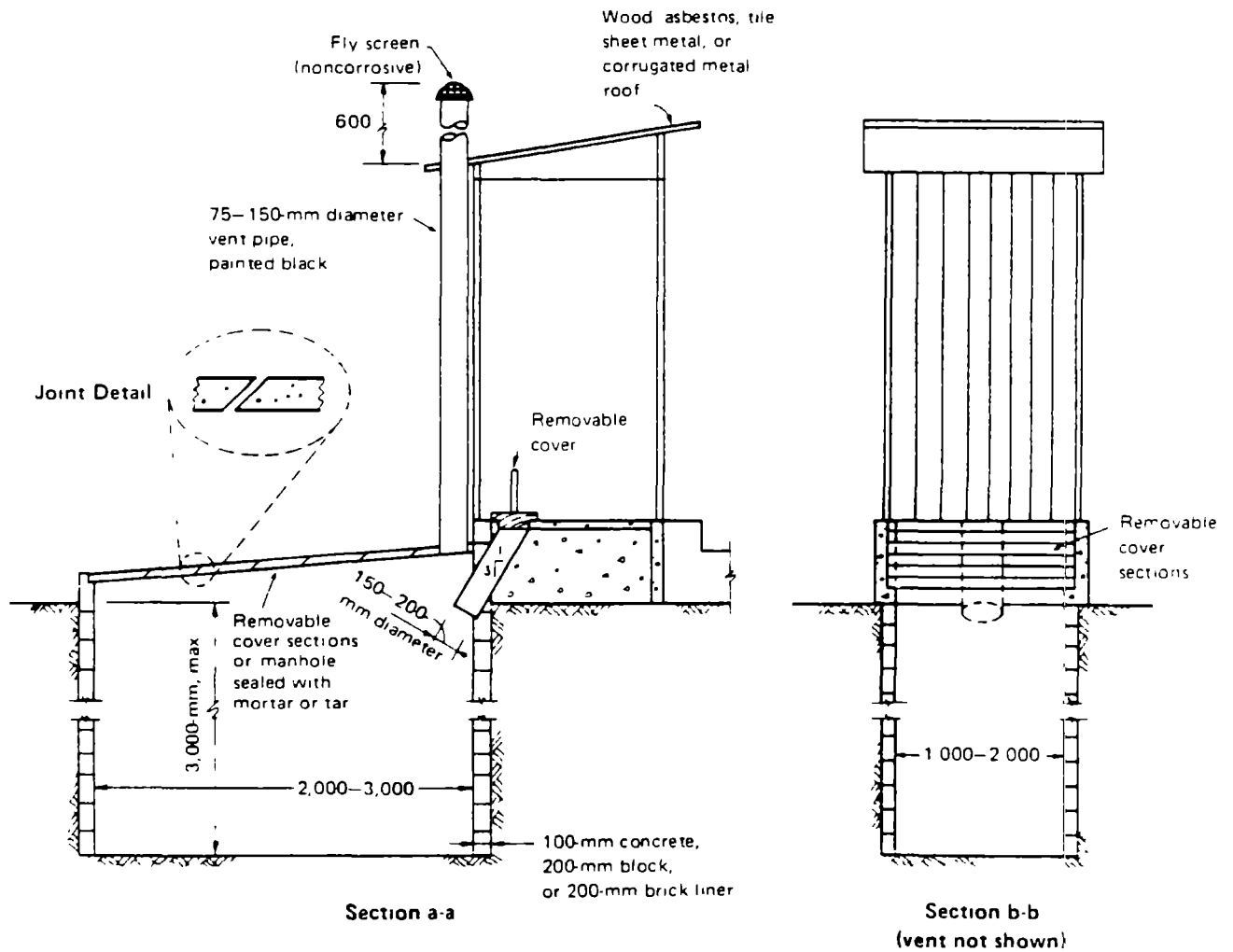

Illus. 21. Reed odorless earth closet (ROEC). (Source: Kalbermatten, et al., *Appropriate Technology for Water Supply and Sanitation, Sanitation Field Manual.*)



DOUBLE-VAULT LATRINE

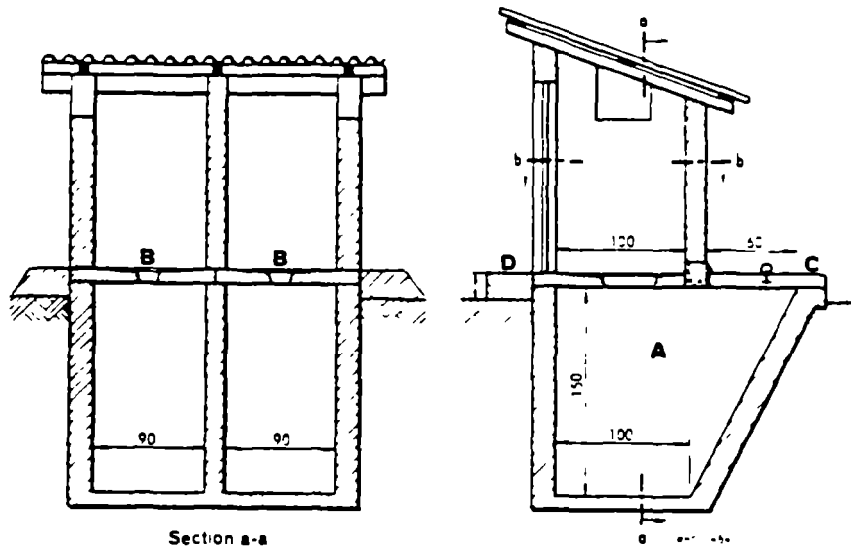

Measurements shown are in centimetres

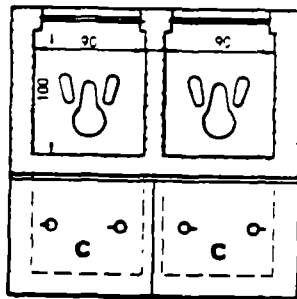

Section b-b

- A = Two vaults
- B = Squatting slabs
- C = Removable covers
- D = Step and earth mound

Illus. 22. Double-vault composting toilet. (Source: Wagner and Lanoix, Excreta Disposal for Rural Areas and Small Communities.)



## Chapter 7

### PREPARING THE IMPLEMENTATION PLAN AND SCHEDULE

The Project Implementation Plan and Schedule is an integral part of the MYP proposal. The plan should include all activities and actions which are necessary for implementation together with a time frame and an indication of which parties are responsible for the activity. Most activities are the project activity targets (PATs), but other critical factors such as budget approvals and agreement signings should also be included either as part of the implementation plan or the pre-implementation conditions.

This chapter provides an overview of important factors to be considered in preparing an implementation plan. For purposes of discussion, the activities have been divided between start-up activities and implementation activities, but there is some overlap and exactly where each activity falls will depend upon the individual project.

#### 7.1 Start-up Activities

The following are some of the important factors and activities that could influence the implementation plan. They are arranged in the form of a checklist for use in preparing the implementation schedule.

##### 7.1.1 Agreements

\_\_\_\_\_ What project agreements are necessary with donors and local governments or agencies?

\_\_\_\_\_ How long will the negotiation and approval process take?

##### 7.1.2 Budget Approvals

\_\_\_\_\_ When can it be expected that budgets will be approved by all funding sources?

\_\_\_\_\_ Are approvals of some donors contingent upon prior approval of each separate funding source's budget?

\_\_\_\_\_ Can the project begin with funds from some sources while awaiting others?

\_\_\_\_\_ What are the implications if some funds are delayed (will staff have to be released or all activities stopped)?

### 7.1.3 Release of Funds

\_\_\_\_\_ Will funds be immediately available upon budget approval or is there a separate procedure for obtaining funds once they have been approved?

### 7.1.4 Staff Recruitment

\_\_\_\_\_ When should new staff be recruited?

\_\_\_\_\_ How will the implementation schedule be affected by recruitment?

\_\_\_\_\_ Will staff training be required?

\_\_\_\_\_ How long will training take?

\_\_\_\_\_ How long will staff recruitment take?

\_\_\_\_\_ Has sufficient time been allotted for interviews and testing?

\_\_\_\_\_ If existing staff are to participate in the project, will they require any special training?

\_\_\_\_\_ How long will international staff require to arrive in country?

\_\_\_\_\_ Will the international staff begin work immediately upon arrival or will an orientation period and language study be required?

\_\_\_\_\_ What are the implications for other activities if the arrival of international staff is delayed?

### 7.1.5 Office and Warehouse Facilities

\_\_\_\_\_ Are such facilities already in place?

\_\_\_\_\_ Are facilities available or must they be constructed, renovated, or rented?

\_\_\_\_\_ How much time and manpower are required for their preparation?

### 7.1.6 Administrative Systems

\_\_\_\_\_ Are financial, inventory, and personnel systems already in place?

\_\_\_\_\_ What new systems or modifications of existing systems will be needed?

\_\_\_\_\_ Do staff require additional training to operate them?

#### 7.1.7 Surveys and Data Collection

\_\_\_\_\_ What information must be collected from the field prior to implementation?

\_\_\_\_\_ Who will collect and analyze the data?

\_\_\_\_\_ Will these people require training?

\_\_\_\_\_ Are any surveys necessary prior to budget or agreement approvals?

#### 7.1.8 Site Selection

\_\_\_\_\_ Is disbursement of funds contingent upon site selection?

\_\_\_\_\_ Which agencies or parties must approve sites?

\_\_\_\_\_ How long is the approval process likely to take?

#### 7.1.9 Vehicles

\_\_\_\_\_ What numbers and types of vehicles are required?

\_\_\_\_\_ How long will it take to purchase and register them?

\_\_\_\_\_ Are delays in shipment or clearance through customs likely?

\_\_\_\_\_ Should a stock of spare parts be purchased in case of breakdowns?

\_\_\_\_\_ Are vehicles necessary to transport materials?

#### 7.1.10 Fuel

\_\_\_\_\_ Is procurement of fuel a problem?

\_\_\_\_\_ Is it necessary to keep stocks on hand in case of shortages?

\_\_\_\_\_ If shortages are common, how will this affect the implementation schedule?

### 7.1.11 Equipment Procurement

- \_\_\_\_\_ What, if any, equipment is required for surveys and implementation activities?
- \_\_\_\_\_ Drilling rigs?
- \_\_\_\_\_ Cement mixers?
- \_\_\_\_\_ Should a stock of spare parts be ordered the same time as the equipment?
- \_\_\_\_\_ What special materials are not likely to be available locally, e.g., water testing equipment, water meters, etc.?

### 7.1.12 Materials Procurement

- \_\_\_\_\_ What materials are locally available and which must be procured outside the country?
- \_\_\_\_\_ What is the normal delivery time for materials purchased from foreign sources?
- \_\_\_\_\_ Can materials be ordered after the designs are completed and approved?
- \_\_\_\_\_ If not, is there sufficient warehouse space available if they are ordered in bulk beforehand?
- \_\_\_\_\_ When ordering beforehand, what minimum surveys or information are required to decide what should be ordered?
- \_\_\_\_\_ What materials are subject to possible seasonal or cyclical shortages? Should they be purchased earlier? (Some materials such as bricks may be available only in the dry season while others such as sand may be more readily available in the rainy season.)

## 7.2 Implementation Activities

### 7.2.1 Design Preparation

- \_\_\_\_\_ How long will it take to prepare designs?
- \_\_\_\_\_ Can the time be shortened by use of standard designs?
- \_\_\_\_\_ What agencies or groups must approve designs before implementation?

\_\_\_\_\_ How long might it take?

\_\_\_\_\_ Is it possible to include a clause in the agreement specifying a maximum time period for a response with agreement assumed if no response is received within the time period?

#### 7.2.2 Land Title

\_\_\_\_\_ Is it necessary to obtain legal title to land for reservoirs or for the spring area prior to implementation?

\_\_\_\_\_ How long might this delay the beginning of construction?

#### 7.2.3 Water Quality Testing

\_\_\_\_\_ Will water quality tests be required prior to site approval?

\_\_\_\_\_ Are testing facilities available and working or must equipment be purchased from outside sources beforehand?

#### 7.2.4 Committee Formation

\_\_\_\_\_ Are water committees required for each water system?

\_\_\_\_\_ Will they be formed prior to technical surveys or concurrently with them?

#### 7.2.5 Community Participation

\_\_\_\_\_ Is collection of a maintenance fund by the community required before implementation?

\_\_\_\_\_ At what point in time should the collection begin, before or after design approval?

\_\_\_\_\_ Can construction begin before the fund reaches a minimum level?

\_\_\_\_\_ If the community is to provide material or labor for construction, will this delay implementation? (If so, schedules must be adjusted to accommodate those of participants.)

\_\_\_\_\_ Will the time of year, weather, or agricultural activities have an effect on community inputs?

#### 7.2.6 Materials Storage

\_\_\_\_\_ Are facilities for storage of materials generally a problem?

\_\_\_\_\_ Will they have to be constructed or rented, and will they influence delivery schedules for materials?

#### 7.2.7 Construction Activities

\_\_\_\_\_ Will the weather affect construction activities?

\_\_\_\_\_ Is there a rainy season when both construction and transport will be difficult or impossible?

\_\_\_\_\_ How will seasonal availability of labor affect the construction schedule?

#### 7.2.8 Training

\_\_\_\_\_ What training activities are required for maintenance, repair and administration of the water system?

\_\_\_\_\_ Will these be carried out prior to, during, or after construction?

#### 7.2.9 Health and Sanitation Activities

\_\_\_\_\_ Are there construction activities for sanitation (e.g., showers, work rocks, latrines, etc.)?

\_\_\_\_\_ Will such activities be implemented during construction?

\_\_\_\_\_ Are there follow-up activities after construction?

\_\_\_\_\_ Will these activities affect the construction schedule?



### 7.2.10 Evaluation

- \_\_\_\_\_ Is baseline information for evaluation included in the initial village surveys?
- \_\_\_\_\_ Are special studies required for some sites?
- \_\_\_\_\_ Will evaluation of each system occur immediately upon completion of construction, after a set time period, at the completion of the entire project, or at different periods?
- \_\_\_\_\_ Who will perform the evaluation?
- \_\_\_\_\_ If outside persons are to be used, how soon should they be requested?
- \_\_\_\_\_ Will independent evaluations occur at regular intervals or only upon project completion?
- \_\_\_\_\_ Will there be any future follow-up evaluations, and if so, have funds been budgeted for them?



## Chapter 8

### PLANNING TO ASSURE LONG-TERM SYSTEM RELIABILITY

The best designed, most skillfully constructed water supply and sanitation projects will provide useful services only so long as they are kept in operating condition. To ensure long-term reliability, a project must have, at a minimum:

- an appropriate design
- a local maintenance organization
- a regional or national support system
- an educated local population
- trained system installers and maintenance staff
- adequate transportation for technicians, materials, and spare parts
- long-term financing for operation, maintenance, and spare parts
- a source of supply for spare parts
- an output which is perceived as vitally important by local users
- a sense of responsibility among the users for keeping the system in working order.

In this chapter, each of these important considerations will be examined in the context of typical rural water supply and sanitation projects. Wherever possible, reference will be made to approaches which have worked in recent CARE programs so that field staff can share in solutions developed by their colleagues.

#### 8.1 The Design Must be Appropriate

Design decisions made during the initiation of a project often have profound impacts on the long-term durability and reliability of a water and/or sanitation system. If the initial design decisions require skills in operation and maintenance which are not locally available, frequent additions of expensive spare parts or lubricants, and frequent downtime for operation and maintenance, then the chances of long-term use of the system will be greatly reduced, despite all of the efforts of the local project manager. "Appropriate" is not just a catch phrase. An appropriate design places long-term durability and maintainability above the natural tendency of engineers to seek the system with the highest technical performance or the most cost-effective delivery of services. For each piece of equipment or technique proposed, three fundamental questions should be asked:

- Are the skills required for the operation and maintenance of the equipment in keeping with those of the local population?

- Does the local population think the service that the equipment will provide is worth the effort required to operate and maintain it? (Some equipment may be too complex to handle.)
- Are the costs for spare parts, lubricants, and maintenance within the means of the local population to support?

The answers to these questions should influence not only the choice of technologies but also materials. Clearly, a higher level of skill is required to join, coat, and line steel pipe sections than to use concrete, PVC, or asbestos-concrete pipes. Similarly, systems that have continuously moving parts and closer tolerances, such as windmills and diesel engines, require much more careful maintenance than handpumps.

## 8.2 A Local Operation and Maintenance Organization Must be Formed

To begin the process of community organization and training for system operation and maintenance, there must first be a focus for CARE activity within the village or town. The CARE field officer has three major options for creation of this organizational center.

First, a special water supply and/or sanitation committee can be formed to provide the local management structure. Illustration 23 shows such a committee holding a meeting. This is a typical CARE practice in many countries with villages that have a history of communal cooperation but little or no experience in project management. The local committee or water users' group is responsible for procuring materials, organizing construction labor, subsequently collecting any water-use fees, and assuring system operation and periodic maintenance. Teaching the committee how to plan ahead, direct local participation, and collect and manage funds becomes one of the major parts of the project development process. Some of the topics that must be covered with the village committee are discussed in the section on education.



Illus. 23. A village committee in Bolivia. (Source: WASH Project.)

Second, the CARE field officer can choose to rely on a pre-existing organization that was created for another purpose but that has already acquired the skills needed to manage a water supply or sanitation project. Examples of pre-existing organizations that have been used successfully to oversee the installation and operation of CARE water supply projects include local diesel mechanics and plumbing contractors' associates and village cooperatives.

Third, local CARE project staff can rely on an external organization, not drawn from the village, to provide basic operation and maintenance services if it is observed that a particular village lacks the infrastructure and organizational experience to provide the required day-to-day project management. While this option has been used in a number of non-CARE pumping programs to provide potable water in sub-Saharan Africa, it violates one of CARE's basic principles--the promotion of community participation and organization as a stimulant to development in a wide variety of areas. In addition, if outside operation and maintenance personnel have to be summoned every time there is a minor problem, the system will inevitably be in working order for less time than if the village handles routine maintenance and service. If the system is not reliable, villagers will make other provisions for their water supply. Most of the project's benefits will be lost if villagers return to polluted, but available, sources of water.

### 8.3 A Regional or National Support System Must Be in Place

While it may not be appropriate to delegate all operation and maintenance responsibilities to organizations outside the system site, external sources of specialized expertise must be available to the local village committee when non-routine problems are encountered or when major repairs are required. Reference is often made by water system planners and equipment manufacturers to multi-tier maintenance systems. This means that there are one or more layers of back-up service to support the local operation and maintenance staff by providing equipment repairs and testing where needed. Back-up services should have specialized tools and large or expensive spare parts and should be capable of trouble-shooting beyond the training of the local staff. In some cases, such as the handpump programs in India, there is a three-tiered (local, regional, and national) support program; while in other cases, it may be a two-tiered system. For the CARE program manager, the most important tier is the local or regional center that supports the local village committees.

The number of local village committees that can and should be supported by a regional center varies according to the density of local installations. For example, one center should be able to support five to 15 handpump installations in areas where there are a number of small scattered villages, each with a single handpump. Trying to service any more than this will put some of the villages too far from the center, making it difficult for rapid response when help is needed. In urban or peri-urban areas, where there may be 10 to 50 handpump installations in a single community, then a large centralized maintenance and repair facility would be logical.

#### 8.4 The Local Population Must Learn How to Use the System Correctly

Education in system operation and maintenance in a CARE water supply and sanitation project is seen as a two-part effort with the two parts occurring either simultaneously or sequentially. The first part of the community education process is generalized familiarization with the system for the whole population. All community members should be made to understand that it is their water supply or sanitation system, not the government's or CARE's. Actions that they should take directly and problems which should be reported to the village committee must be spelled out in detail. Preventing system abuse and unsanitary practices (e.g., by keeping farm animals away from water points or by making sure water sources are sealed from groundwater intrusion) is the responsibility of every user, not just the village committee. Similarly, shutting off taps, but not over-tightening them, is also a personal responsibility. Leaks in the pipeline or broken pump handles should be reported to the village committee.

Of course, generalized education concerning system operation and maintenance must be linked to the overall effort to integrate a new water system with other behavioral changes that will improve health and sanitation. The importance of linking the water system to new sanitation practices--e.g., frequent bathing (particularly for children), washing hands before preparing food, etc.--must be explained in detail before the system is installed.

#### 8.5 System Operators and Maintenance Staff Must Be Trained

The second educational component of a CARE water supply and sanitation project is specialized training for the village committee. While the committee's composition will vary across sites and countries, it will normally include one prominent village leader or headman; a treasurer responsible for collecting and disbursing funds; two or more operators; and, if possible, a skilled repair person, such as a welder, machine shop operator, diesel mechanic, farm machinery service specialist, etc. Committee members must receive a concentrated program of training in operation and maintenance. At a minimum, this should include:

- System design--the rationale behind the system's layout.
- Routine maintenance--hands-on experience with performing the required preventive maintenance for the system.
- Maintenance scheduling--determining when the next maintenance step is needed and assuring that any required parts are ordered or stockpiled before they are needed.
- Trouble-shooting--ascertaining what is wrong and the steps to be taken next.
- Repair or replacement of worn parts.

- Major overhauls of key pieces of equipment--how to do such work or get it done by others. (This is particularly important when small engines or pump sets are in operation.)
- Administration and bookkeeping.

Training, in terms of both generalized community education and detailed hands-on practical experience in parts replacement and trouble-shooting, is the basis for an effective operation and maintenance program. Trained manpower must always be considered the top priority of the supervisor of project operation and maintenance and should be under development even while the project is still being constructed. Endless supplies of spare parts are useless if there is no one available who knows how, when, and where to install them. Illustration 24 shows a pump caretaker at work.



Illus. 24. Local caretakers for pumps. (Source: Michel Jancloes.)

Training is not only an important part of building local operation, repair, and maintenance capabilities; but it should also be a prime consideration in the choice of technologies, designs, and materials. If individuals from the community or nearby areas cannot readily be trained to work on a proposed system, then either the selection process or choice of the village for the installation should be reconsidered. Given the range of technologies normally incorporated in CARE water supply and sanitation programs, this scenario rarely occurs; but it does serve to emphasize the importance of operation and maintenance in the phases of project design, installation, and operations.

For purposes of this analysis, water supply programs are arbitrarily categorized on the basis of their underlying design and the training requirements for each are addressed separately. Sanitation programs will focus on simple waste disposal systems.

#### 8.5.1 Training Requirements for Gravity-Feed Water Supply Systems

Local operators need to acquire a variety of skills to operate, maintain, and trouble-shoot this type of system. Some of these skills are also needed to operate and maintain handpump systems, primarily those related to water quality testing, detecting leaks, and preventing system contamination. An abbreviated list of some of the operation and maintenance skills that the local committee should possess prior to commissioning a gravity-feed system is as follows:

- Map reading--operators should be able to follow a system schematic so they can locate joints and junctions in buried pipes, emergency shut-off valves, pressure relief valves, clean-outs, filters, etc.
- Chemical water treatment--wherever it is needed, operators must know how to load and maintain chlorinators or similar devices to ensure continuous disinfection.
- Pressure testing and leak detection--one of the most important responsibilities of operators is to periodically examine the system for signs of breaks, corrosion, and mechanical failure.
- Repairing leaks--several individuals in the community should be experienced in making simple repairs or, at the very least, should know how to summon qualified outside specialists.
- Disinfecting pipelines after completing repairs--local village operators should have the skills and equipment to flush mains and distribution lines after a repair.
- Routine flushing of water mains.
- Routine cleaning of filters and traps--this includes knowing how to refill the system once it has been emptied and where required materials are located.



- Preventing contamination--this includes the prevention of bad practices (allowing animals near a water point) and repairing key contamination barriers (water runoff channels, covers over reservoirs, etc.).

#### 8.5.2 Training Requirements for Handpump-Dependent Water Supply Systems

While less costly and complex to plan than gravity-feed systems, groundwater supply systems that use handpumps require a more organized program of operation and maintenance. (Illustration 25 shows the maintenance points on a handpump.) Many of the concerns with a handpump system are the same as for a gravity-feed system, but a major program of routine pump maintenance and lubrication as well as a spare parts inventory must also be established. An outline of topics that should be covered in a training program for a handpump system is as follows:

- Chemical disinfection--in the event that contamination is discovered, operators should have the skills and tools to disinfect the water source.
- Pump assembly and disassembly--operation and maintenance personnel should be thoroughly knowledgeable concerning all the parts, especially those most prone to breakdown and malfunction. These groups also should know how to assemble and disassemble the pump model used in the village. Training should include practical exercises, using the set of tools that will later be owned by the village committee.
- Routine lubrication and visual examination--this should be practiced a number of times by the operators in a series of hands-on exercises.
- Parts replacement--operators should be aware of what worn parts, seals, and gaskets look like as well as the required procedures for replacing them.
- Major overhauls and inspections--pulling the cylinder and other such activities should be practiced during training.
- Preventing contamination--operators and other members of the village committee should know what practices should be discouraged and how to make structural repairs to prevent groundwater or fecal contamination of wells or storage tanks.

#### 8.5.3 Training Requirements for Simple Waste Disposal Systems

This category covers the construction of virtually all of CARE's remote village sanitation facilities, such as pour-flush privies and pit, ventilated

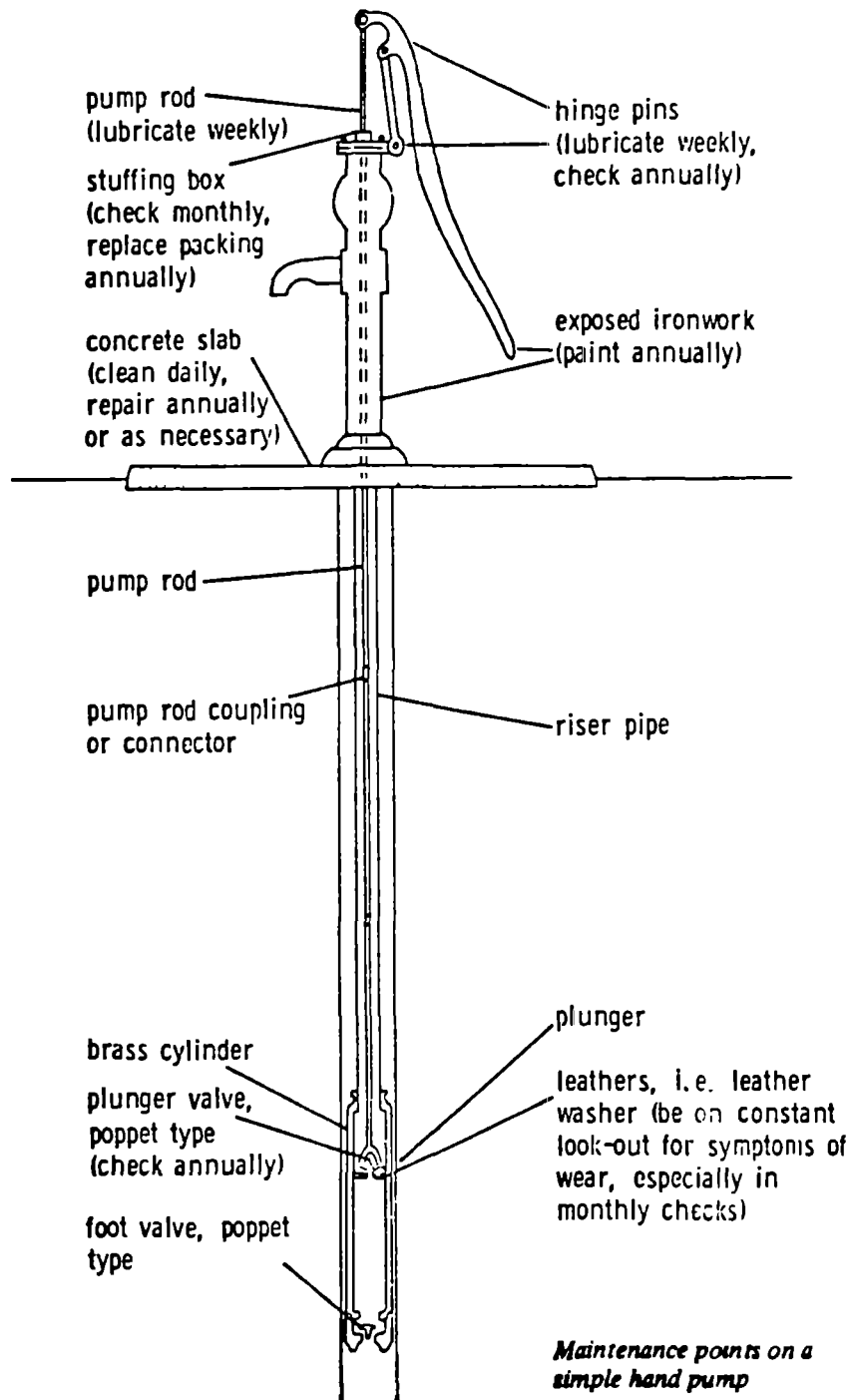

Illus. 25. Maintenance points on a simple handpump. (Source: Pacey, Handpump Maintenance.)

improved, and vault latrines. In these cases, training in the operation of the system is directed at all village residents and includes such practices as putting the cover in place, using the water flush (in the case of pour-flush privies), periodic washing and disinfection of the privy slab, washing hands after using the facility, etc. Most of these chores fall upon village women, so a substantial portion of the general education program on system operation should be directed at them. Another option is to assign the responsibility to one or more designated operators, who should be trained to:

- assist villagers in slab production
- periodically add ashes to the privy or latrine to disinfect it
- repair structural problems with the slab, pit lining, and protective structure, if there are any
- clean out the pit or vault when it becomes full
- dig or supervise the digging of pits or vaults and the construction of additional latrines and privies.

#### 8.6 Adequate Transportation for Technicians, Materials, and Spare Parts Must Be Available

Most CARE water supply and sanitation projects are set up on a regional basis with a team of system designers, installers, troubleshooters, and maintenance specialists who work throughout the region. A number of visits are required to each site, particularly if there is a baseline study to be done and the CARE program staff has to work with the local villagers to identify their interests and needs. At later periods, drilling rigs, bags of cement, and numerous parts have to be carried out to the site. For all of these activities, well-maintained and fueled vehicles are needed. The lack of operating vehicles or shortages in fuel and lubrication have often proved to be major stumbling blocks for CARE water supply projects, so adequate provision should be made well in advance to minimize any potential vehicle-related disruptions.

#### 8.7 Long-Term Financing of Operations and Maintenance Must Be Assured

After the construction and testing of a water supply and/or sanitation project is completed, additional funds are required periodically for spare parts, lubricants, disinfection chemicals, and repairs. If the system is large or includes one or more mechanized pumping units, there may be a need for one or more paid operation and maintenance person(s). In addition, there should be a contingency fund for unanticipated expenses.

There are a number of ways to finance operation and maintenance costs. The technique preferred by most operations and management planners is to have the village water users' group or committee collect a set fee every month from all users. The amount can be the same for each household, which is normally the easiest system to administer, or based on a sliding scale, depending on wealth or the number of individuals in each household. The treasurer of the village committee is usually responsible for collecting and disbursing these funds, as this individual is usually given some information about rudimentary bookkeeping as part of the committee's specialized training.

In most cases, this ideal system does not last for long. Instead, when something breaks down or when the village maintenance crew runs out of a key spare part or lubricant, a collection is taken from the system users, either through some type of assessment or through voluntary contributions. When enough money is raised, the repair is made or the needed parts are bought. For some highly organized communities with a previous experience of cooperation, this approach is probably often sufficient.

There is no definitive rule about the proper size for an operation and maintenance fund. It will depend on the ability of the individuals within the community to pay, on the frequency with which parts must be serviced or replaced, and on the costs of the parts or services to be purchased. At a minimum, the fund should be large enough to pay the salary for one worker, plus an equivalent amount for other spare parts. Thus, if the operator/maintenance staff is paid \$14.00 per month, then a fund of \$28.00 per month should be set up through the monthly users' fees.

In addition to monthly user fees, there are several other ways to collect operation and maintenance funds. For communities with very small cash incomes, it is possible to levy a fee of so many units of a local foodstuff payable at harvest time. While such a system is manageable, it does have a number of problems. First, the foodstuffs have to be converted to cash or bartered for the required spare parts, which is a time-consuming and uncertain process. Second, there is a natural tendency to pay the fee with less desirable foodstuffs, keeping the best for personal consumption or sale. Third, a bad harvest season will disrupt the operation and maintenance funding of the water supply system for an entire year. Fourth, the operation and maintenance "fee" is levied only once a year, which will make it seem like a larger amount than if it were paid in two or four equal installments. Of course, for some communities cash income is available only once a year, during the harvest season, so this might be a moot point. Nonetheless, this is a less desirable option for generating operation and maintenance funds.

Another option is for the community to undertake an income-generating activity in conjunction with the water supply system and then to use a portion of the income to pay for operation and maintenance of the water system. High-value crops that require limited space, such as vegetables and fruit trees, can be grown in close proximity to one or more water points with runoff from the taps used for irrigation. The produce can then be sold with a portion of the proceeds earmarked for operation and maintenance of the water supply system. To work well, such a program must be run by the community, rather than one or two individuals and most of the users of the community water system must agree to work on the income-generating project regularly.

## 8.8 Spare Parts Must Be Supplied

Providing spare parts for water supply and sanitation projects is often neglected, but it is a crucially important determinant of the system's long-term dependability and reliability. Spare parts must be readily available, or even the most highly motivated local operators will not follow routine preventive maintenance schedules. Without a local stockpile of spare parts, minor problems can bring the entire system to a complete halt for weeks or months at a time. At the very beginning of the design phase for each project, planners must consider what parts need to be stockpiled and the quantities of each to be kept on hand, where these supplies will be stored, and how parts will be transported.

### 8.8.1 Determining What Spare Parts Are Needed

When a water supply or sanitation project is in the final stages of construction, the local village committee should be provided with ample spare parts and tools. This supply should include all routine maintenance items--lubricants, oils, seals, gaskets, pump leathers, etc.--and the tools required to install them. Items such as spare cotter pins, bolts, and nuts should be a part of the local mechanic's basic tool kit. There should also be at least one set of key major replacement parts available from a nearby central supply facility. For handpumps, these key replacement parts include such things as pump cylinders, casings and screens, additional chains (in the case of India Mark II pumps), and pump handles. For gravity-feed systems, additional replacement pipeline sections, couplings used to join pipeline sections, spare distribution lines, taps, etc. should be stocked.

One of the primary problems confronting major water supply programs is the fact that a number of different systems or even different models of the same pump may be installed in the same areas. A small number of standardized technical options should be decided upon as early as possible in a water supply program so that the number of different sets of spare parts which must be ordered and kept on hand can be minimized. This is particularly crucial for imported systems, regardless of type. Because of the long lead times required for the delivery of spare parts, an inventory of replacement parts for a full year should be constantly maintained.

### 8.8.2 Specifying Quantities

It is difficult to specify the quantities of spare parts to order at the inception of a project and how many to maintain on hand in the local inventory. For machines, such as handpumps and wind/water pumpers, the manufacturer's guide to spare parts can often be helpful. Table 3 is an example provided by a manufacturer of one handpump.

Table 3

RECOMMENDED SPARES FOR EACH INDIA MARK II  
DEEP WELL HANDPUMP FOR TWO YEARS' OPERATION

<u>Spares for Pump Head:</u>	<u>Qty. (Nos.)</u>
1. Hexagonal bolts M 12 x 1.75 x 40	12
2. Hexagonal nuts M 12 x 1.75	24
3. Washer M 12	12
4. Hexagonal bolts M 10 x 1.5 x 40	4
5. Nyloc nuts - M 10	6
6. Axle	1
7. Bearing	2
8. Sockets	2
9. Chain with coupling	2
10. Bolt & nut for cover M 12 x 1.75 x 20	4
11. Front cover	1
12. Spacer	2
13. Special washer for axle	2
 <u>Spares for Cylinder:</u>	
1. Leather cup washer	8
2. Leather sealing ring	12
3. Rubber seating (big)	4
4. Rubber seating (small)	4
 <u>Spares for Connecting Rod:</u>	
1. Hexagonal coupling M 12 x 1.75 x 50	5
2. Hexagonal nut M 12 x 1.75	10
3. Connecting Rod 12MM dia. & 3 metres length	3

The spare parts inventory should be replenished as it is used so that there is always at a minimum a six-month supply of parts fabricated in-country and a year's supply of parts that must be imported.

In some cases, the responsibility for financing and maintaining an inventory of spare parts can be assumed by a vendor in the private sector. For example, in countries where a large number of diesel pumps are in use, there are often complete sets of spare parts for the most popular models even in small market towns. In such cases, the community does not have to maintain such a large inventory of spare parts.

### 8.8.3 Location of Spare Parts Inventory

Spare parts for routine preventive maintenance and the tools required to install them should be kept somewhere within the local community. The best location for larger spare parts, which need to be replaced only infrequently, is partly a function of the number of water supply or sanitation systems installed in a district or province. In areas where CARE is mounting a major program of system installation, if the technologies being used are standardized and transportation is good, major replacement parts can be kept in a number of program warehouses scattered strategically throughout the region. This scheme reduces the expense of maintaining a complete stockpile at each site while the parts are still readily available. Each centralized spare parts inventory should generally serve 10 to 20 sites that are within one day's travel of the stockpile.

### 8.8.4 Transportation of Spare Parts

Spare parts are not useful if they cannot be delivered to the site where they are needed. Regional parts repositories should have both the vehicles that can carry the parts and the fuel to power them. Generally, one or two small trucks or four-wheel drive vehicles are sufficient although inaccessibility of some village sites may well require use of motorcycles or motor scooters to bring in small but crucial spare parts.

## 8.9 The System Must Be Perceived as Vitally Important by Local Users

Local villagers will be willing to provide maintenance funds, labor, and part or all of the initial investment funding if they find the output of the system to be important. This is one reason why we have stressed the central need for community participation throughout this guidebook. If the local villagers have been involved from the start in the design of the project, the selection of the technologies to meet their perceived needs, and the choice of applications, then it is their project. It will reflect their interests and desires. In some cases, the addition of a village garden, bathing facility, or washing pads to a central handpump or waterpoint will greatly increase village interest in taking care of the facility.

## 8.10 Users Should Feel Responsible for Keeping the System in Working Order

This is a corollary of the point just discussed. The users of the water or sanitation system should not feel that it is the job only of the village committee or an outside technician to take care of the system, to make minor repairs, to keep animals away from the water points, to prevent children from playing or defecating in the spilled water, etc. A shared sense of responsibility and ownership will be important when funding or labor is required for system maintenance, spare parts, and training.





## Chapter 9

### EVALUATION OF WATER SUPPLY AND SANITATION PROJECTS

There are at least two main reasons for evaluating a water supply and sanitation project. One is to determine how well a project is progressing, whether or not there have been problems, or whether the project is progressing as it was planned. An evaluation that provides that kind of information is known as a process or a mid-term evaluation. It can be done at any point during the life of a project. The second reason for evaluating a project is to determine whether or not there has been an impact and, hence, whether or not it should be continued. This type of evaluation is called an impact or an outcome evaluation.

The value of an evaluation is partially a function of staff concern with project progress. If things are going well, staff may feel less need for an evaluation and the feedback it can provide on project developments.

#### 9.1 An Evaluation Framework

In order to effectively evaluate a water supply and sanitation project, one needs to have an evaluation framework. The framework suggested in this chapter is illustrated in Figure 4. As can be seen in the figure, there are three levels of evaluation. The first is the operational level, in which system functioning is examined. At this level, theoretically, all factors which lead to the functioning of the system are under the control of the system implementer. The end point in a water supply system at this level is the water coming out of the pump or the tap. The major question then is whether the system is functioning as it was designed.

The second, or utilization, level is beyond the control of the implementer. At this level two major factors are of importance in determining use. One is community support for the operation and maintenance, revenue collection, and the health education of the population in proper water use. The second major factor is the household use factor. There one looks at quantities of water consumed, the quality and cleanliness of latrines, and what the water is used for.

The third level concerns outcomes or impacts, of which there are four types: environmental impacts of the water supply and sanitation system (for example, the cleanliness of the village); social impacts (for example, the saving of women's time in fetching water); economic impacts (those associated with the use of water for brick making, beer-making, gardening, irrigation, etc.); and lastly, the health impacts, including both health status impacts and impacts in terms of health knowledge, attitudes, and practices.

Impacts are costly and difficult to measure and to evaluate without a sophisticated data collection system. In the following paragraphs, therefore, we shall concentrate on level one and level two outcomes of water supply and sanitation projects, those regarding function and utilization of systems.

# Figure 4

## IMPACT EVALUATION MODEL

■ OPERATIONAL LEVEL 1  
(FUNCTION)



● TECHNICAL FACTORS UNDER THE CONTROL OF THE SYSTEM IMPLEMENTER

■ PERFORMANCE LEVEL 2  
(UTILIZATION)



● OPERATION AND MAINTENANCE  
● REVENUE COLLECTION  
● HEALTH EDUCATION

● QUANTITIES OF WATER  
● CLEANLINESS OF LATRINES  
● TYPES OF WATER USE

■ IMPACT LEVEL 3  
(OUTCOMES)



SOURCE: Adapted from Warner, D.B., 1980

## 9.2 Level 1 or Functional Outcomes of Water Supply and Sanitation Projects

Outcomes at the functional level are totally under the control of the organization that has installed the system. The factors leading to system function are mainly technical. Once the water is coming out of the pump or tap, we immediately enter into second level outcomes. The question as we have earlier stated at this level is whether or not the system is functioning as it was designed and whether or not it is producing water at the far end of the system. These are questions that need to be posed to the engineers in charge of the system. Typical questions would include the number of installed systems and the number of operational systems. Frequently, evaluations performed by agencies don't go any further than these two questions.

## 9.3 Performance Outcomes

Outcomes at the performance level concern the utilization of water or sanitation facilities by the populations for whom they are destined. Factors influencing the use of facilities for water include the distance to the source. No matter how pure the water may be, or how abundant the outflow, if the distance exceeds that from which a woman can normally carry one or two vessels once or twice a day, then the volume of water will probably not exceed around 15 liters per person per day. Therefore, the water supply facilities should be at a sufficiently short distance from dwelling places in order for the volume of water consumed by the population per day to be increased.

Vessel size also influences the amount of water consumed. In their study, White, Bradley, and White found it to be a critical factor in East Africa. Those having larger vessels were capable of bringing larger volumes of water home.

Habit is another important characteristic. If people have been accustomed to consuming small amounts of water, it will be a matter of time before a more abundant source will result in an increased volume of water consumed. Belief is also an important factor, particularly with regard to the use of water for washing the home, baby, hands, and food and even for drinking water; all of these are influenced by personal habits and beliefs related to local custom.

Lastly, one should mention local organization. If there is no local organization, a supportive network for behavioral changes with respect to water use will not be possible. Then local custom as it has been carried on traditionally will prevail. However, local organizations can become effective vehicles of health education and behavioral change. Of particular importance would be the knowledge that there are local organizations of women which can have an influence on the use of water supply facilities and sanitation by their peers. A list of questions for level two evaluations, therefore, would include the following:

1. What is the distance from dwellings to the sources of water?
2. How is water drawn from the source?

3. What is the typical vessel used to draw water?
4. How many of these vessels are carried away from the source by each person?
5. Is a clean vessel used to draw water?
6. Is the vessel cleansed before the water is put in it?
7. Where is water stored in the home? Is the vessel in which water is stored cleansed on a regular basis? Is it covered?
8. For what is water used--drinking, bathing, washing hands, washing food, preparing food, cleaning the house? How often?
9. With regard to latrines: are they clean; are they covered; are they ventilated; most importantly, are they used?

#### 9.4 Impact Evaluations

As already mentioned, evaluations of this type are costly and time consuming. Nevertheless, many CARE offices in the field feel that some part of the evaluation should be devoted to this level.

Under health impacts, one can look at three categories of evaluation criteria: those related to mortality, those related to anthropometry or body measurement, and those related to diarrheal morbidity. Mortality measures are of many different types but the most useful for evaluation purposes is the infant mortality rate, if that can be estimated. It is not recommended, however, unless the project itself is collecting mortality data or the government of the country in which the project is carried out has good mortality data available.

Anthropometric measures ( e.g., body weight, height, arm circumference) can be useful in evaluating a project because they can be taught to field workers; require relatively unsophisticated, inexpensive equipment; and reflect one impact of water supply and sanitation projects, decreased diarrheal morbidity. If diarrheal morbidity is decreased, then the weight loss associated with it will also be decreased. Perhaps a greater usefulness of anthropometry data, however, is in assuring that comparisons between groups of children on other health impact variables are more validly made.

Also, diarrheal morbidity itself may be measured, although with greater difficulty than anthropometry which is a variable that can be expressed more precisely. Diarrheal morbidity may be estimated either as the number of days of diarrhea or the number of episodes of diarrhea during the previous week, or the previous month, this question being posed to the mother of the child. Measures of diarrheal morbidity, however, suffer from lack of reliability.

Social impacts of water supply and sanitation projects are even more difficult to measure than health impacts. Data are extremely qualitative and impressionistic. For example, one can try to ascertain whether women are spending less time fetching water by questioning them about their impressions of the amount of time they currently spend getting water compared with the amount of time they formerly spent getting water. In a more sophisticated way, one can actually measure the time using a stopwatch, but this is extremely time consuming and takes reliable field workers.

Other social impacts might include looking at the effect that organizing the community for a water supply project has had on other developmental activities. However, this would necessitate a longitudinal approach to the communities in question. Environmental impacts may be observed from improved water supply and sanitation projects. But again qualitative data are about all that can be ascertained. Are there fewer flies in the community? Is the community cleaner? Has there been any improvement in housing?

Lastly, economic impacts may be ascertained as a result of the water supply system now in place in the community. Has brickmaking been increased? Has water been used for a pottery mill or for a grain mill? All these and other questions with yes and no answers can be ascertained.

In summary, there are three levels of evaluation. The first has to do with the question of whether or not the system is functioning. Is the tap producing water? Is the latrine in place? Are the other environmental health facilities constructed? These questions can be answered by simple observation. The second level has to do with the utilization of the facilities by the population. The answers to the questions in this category are more difficult to obtain. The population itself must be questioned and observed as it draws water, carries water, and uses water in the community. Latrines must be inspected for their use and cleanliness. Other environmental facilities, such as garbage pits, other forms of solid waste disposal, and control of domestic animals, must be observed to see if they are affected. The third level of evaluation, one which we recommend not be used unless there are special circumstances warranting it, requires the collection of data in the field on health, social, environmental, and economic aspects. For evaluation purposes, therefore, it is better to know that a system is functioning and being used and to assume that, as a result, there are health and other effects, than it is to launch completely into a massive data collection effort.

### 9.5 Additional Considerations

In deciding how to conduct an evaluation, several additional factors should be considered. Should country staff or external evaluators carry out the activity? Staff generally cost less than consultants, and they may well have greater initial knowledge about the project. Time for the evaluation may be programmed in addition to other staff activities. However, this may not be an option. Under those circumstances, consultants may provide a desirable alternative for several reasons: (1) Because they are not associated with the project in a working relationship, they may be more objective in their assessments. (2) They may gain access to knowledge which CARE staff people may have difficulty getting precisely because they are associated with the project. (3) Short-term consultants may bring a high level of expertise and different perspectives to the evaluation, which often result in new insights and valuable adjustments in project strategies. (4) Consultants can usually devote full time to the evaluation with the result that they rapidly get a fairly full picture of the project situation. External evaluators can often be found in the project country, e.g., social scientists, etc.

Evaluations require considerable human resources. Typically, the simplest evaluation will demand at least a person-week of time for design, execution, and assessment. The first and second level evaluations described in this chapter will rarely require more than two person-months of time.

USEFUL REFERENCES ON WATER SUPPLY AND SANITATION  
PROJECT EVALUATION

World Health Organization. Minimum Evaluation Procedure for  
Water Supply and Sanitation Projects.

APPENDIX I

Sample Site Selection Criteria





## SAMPLE SITE SELECTION CRITERIA

The proposed water project will be in the northern province of the country. The government has identified this as a priority area because it is the poorest province and the one with the most health problems. After assessing the level of development in the area, it was decided that the project would focus exclusively on spring-fed gravity-flow water systems and handpumps. The following site selection criteria were then formulated.

### Primary Criteria

The following are primary criteria that all projects must satisfy:

1. The community must be under the authority of the Northern Provincial Governor.
2. The present source for drinking water must be at least 500 meters from the center of the community.
3. The community must have formed a water committee and collected an initial capital fund of \$250 for a gravity system or \$50 for each planned handpump.
4. A spring-fed gravity-flow system or handpump must be feasible.

### Secondary Criteria

Fulfillment of the following criteria is not essential but preference will be given to those communities that fulfill more of them than other communities.

1. Health records or field observations indicate that more than 25 percent of medical problems are water-associated diseases.
2. An outbreak of waterborne disease has occurred within the last two years.
3. There are no protected water sources in the community.
4. The community agrees to supply all unskilled labor.
5. The per capita cost of the water supply is less than \$35.

### Technical Criteria

The technical criteria must be satisfied for all water supplies.

### Handpump Criteria

1. Community users agree with the proposed location of the handpump.

2. There is sufficient indication that drilling/digging will yield an acceptable supply.
3. The site must be at least 30 meters from any sanitary disposal facility (septic tank, pit latrine, or drain that receives human waste).
4. A satisfactory drain can be constructed to carry away wastewater, or construction of a seepage pit is possible.
5. There is sufficient land area to install an apron three meters square.
6. All local residents will have access to and free use of the pump.
7. The handpump will serve the needs of at least 50 people or 10 households.
8. The community accepts responsibility for pump maintenance and repair, and two persons attend the project training course.
9. A written statement is obtained from the landowner ceding the land for use as a public water source.

#### Gravity-Flow System Criteria

1. The spring will supply a minimum of 20 liters per person per day.
2. The water to be used for the system is not already used for irrigation or other similar uses.
3. Clear title for the community is obtained for all land needed for reservoirs, fountains, and the spring protection.
4. A satisfactory drain or seepage pit can be constructed for each fountain.
5. The community accepts responsibility for maintenance and repairs, and two persons attend the project training course.

APPENDIX II

Sample Village Questionnaire



SAMPLE VILLAGE QUESTIONNAIRE

a. Surveyor \_\_\_\_\_

b. Date \_\_\_\_\_

1. Village Name:

2. District Name:

3. Estimated number of houses:

Estimated village population:

What is the source of the above information?

4. Type of settlement:

single concentrated area

several concentrated areas (specify number) \_\_\_\_

evenly dispersed over wide area

nomadic

5. List the names and description of village leaders and contact persons:

6. List any existing village development committees and briefly describe their area of focus:

7. Describe any completed or ongoing village self-help projects, including details on the cost, time period for completion, sources of funds, when completed, and the persons who organized them.

8. What is the general community feeling regarding domestic water supply? (Check as many as are applicable).

there is no perceived problem

there is insufficient quantity of water available

the quality of available water is poor

available sources are not reliable

the distance to available sources is too great

water is not available in the home

9. What priority does the community assign to water supply improvements?

no improvements deemed necessary

other problems should be solved first

ranks equally with other problems

more important than other problems

10. Describe any previous actions the community has taken to improve its water supply:

11. Briefly describe any notable problems with water-associated diseases in the recent past:
12. Has there ever been a water system in this village? If no, skip to question 21; if yes, briefly describe it:
13. Is this system still functioning?
  - very well
  - partially
  - not at all
14. If it is not functioning well, what are the main reasons?
15. What percentage of the population does the system serve?
 

0-25	26-50	51-75	76-100
------	-------	-------	--------
16. For what purposes is the water system used? (Check as many as are applicable.)
 

drinking/cooking production	bathing toilets	laundry	irrigation
--------------------------------	--------------------	---------	------------
17. What is the approximate number of private house connections in the system?
18. When and by whom was the system built?
19. Are any user fees collected? If so, describe them.
20. Is there a water committee and are there any paid or unpaid maintenance personnel? Describe:
21. Describe any water sources in use at present and their approximate distance from the people who use them:
  - springs:
  - open wells:
  - sealed wells with handpump:
  - rivers:
  - ponds:
  - rainwater:
  - other (describe):
22. Describe the most frequently used source of drinking water, its general quality, and its distance from the village center:
23. Describe any suitable springs in the area for possible development. Are they perennial; are they above the village; are they already used for irrigation?
24. Describe the potential for groundwater development through drilled or hand-dug wells. What type of wells exist; what is the depth of the water table; what is the quality of existing wells; do they go dry in the dry season?

25. Briefly describe any water improvements suggested by the community:
26. Briefly describe the type of water improvements that may be technically and economically possible for this community:
27. Briefly describe any follow-up action such as spring flow measurements, checks on distance or elevation, etc. that would be required to establish technical feasibility:
28. Rate the community on level of interest in improving their water supply:
  - very interested
  - interested only if someone else makes the improvements
  - not interested





APPENDIX III

KAP Survey

\_\_\_\_\_

-

-

-

-

-

-

-

-

-

-

-

-

-



WORLD BANK RESEARCH PROJECT 671-46

SOCIOLOGICAL QUESTIONNAIRE ON WATER SUPPLY, WASTEWATER AND  
EXCRETA DISPOSAL

The main purpose of these questions is to find out how people think about their present method of water supply and excreta disposal, as a means to estimate future response to proposed changes and to enable them to take part in the decisionmaking concerning those changes. It is necessary to find out what they think about their present environment, whether it is a healthy place to live, and whether they would be willing to work with others to make improvements in their present methods.

The questions must make sense to the person being interviewed. Therefore the interviewer must be able to speak the local language, understand the kind of information needed, and adapt the language to the understanding of the person interviewed.

Preferably the questions should be addressed to women, since they are generally more knowledgeable about water use in their family unit. Whenever possible, use direct observations such as: "show me where you and your family dispose of fecal materials," or, "show me where you obtain your water." In most cases, women interviewers will be more successful than men in obtaining answers from women. Some questions should be asked of the man of the house, for example, "would you be willing to work with others in order to improve your water supply."

DATE \_\_\_\_\_ COUNTRY \_\_\_\_\_

STATE/DEPARTMENT \_\_\_\_\_ LOCALITY \_\_\_\_\_

NAME OF INTERVIEWER \_\_\_\_\_ ORGANIZATION \_\_\_\_\_

COMMENTS \_\_\_\_\_

\_\_\_\_\_

\_\_\_\_\_

\_\_\_\_\_

Questions 1 and 2. Objective: Determine who carries the water, what are the water sources and how are they used. Investigate whether it is considered good or bad to the interviewed person concerning water supply.

Answers to following questions will be written in Tables I, II, and III.

Question 1. a) From where do you obtain most of your water during summer?

b) During winter?

(for the main source of water write 1 in parenthesis and 2 for the source next in importance.)

c) Who brings water to the house? In what container? How many trips per day must this person make in order to obtain water?

(Fill in Table I according to answers obtained.)

TABLE I

Family member	Container used for carrying water	Estimated capacity	Daily trips for water	
			Summer	Winter

d) Approximate distance from house to water source.

e) How long does it take round trip to get water?

f) When did you start to use this water source?

g) For what purpose do you use this water?

h) How did you find out that this water source existed?

i) Why do you get your water from this place?

(Once you have completed the first water source, ask if they obtain water from another place as well. Mention uses and water sources you think are available.)

(After completing Table II, fill out Table III. First determine from where they obtain their drinking water, then ask:)

Question 2. a) Why do you prefer this water for \_\_\_\_\_ (use)?

b) What do you dislike about the water from this source?

(Repeat the same for other uses given on Table III.)

Questions 3,4,5,6,7 and 8. Objective: To find out if the interviewed associates water use with health and if he would be willing to spend more money or work harder in order to obtain improvements.

Question 3. Do you have any problems obtaining water from these sources?

Yes ( ) No ( )

(If the answer is yes, ask in which place and what is the problem.)

Place

Problem

---

---

---

Question 4. Do you think your house is located in a healthy place?

Yes ( ) No ( ) Don't know ( )

Why: \_\_\_\_\_

(If the answer is "don't know," try to find out what the interviewed believes is a healthy place and then repeat the question.)

Question 5. Do you believe the water you drink is healthy for you and your family?

Yes ( ) No ( ) Don't know ( )

Why: \_\_\_\_\_

TABLE II

Source	Summer	Winter	Distance to house	Time spent to and from source	Years using this method	USES						How did you find out about this place?	What made you decide to obtain water from this source?
						Drinking	Cooking	Bathing	Laundry	Animals	Plants		
<input type="checkbox"/> Spring													
<input type="checkbox"/> Shallow well													
<input type="checkbox"/> Deep well													
<input type="checkbox"/> Public fountain													
<input type="checkbox"/> Faucet inside house													
<input type="checkbox"/> Faucet in patio													
<input type="checkbox"/> Faucet at neighbors													
<input type="checkbox"/> Rain													
<input type="checkbox"/> Creek													
<input type="checkbox"/> Puddle													
<input type="checkbox"/> Other (specify)													

**TABLE III**

	Source	Why do you prefer the water from this source?							What is it you don't like about this water?						
		Color	Taste	Smell	Free	Inexpensive	Close	No problems with others	Other Reasons	Color	Taste	Smell	Too far	Expensive	Problems with others
Drinking	1														
	2														
	3														
Cooking	1														
	2														
	3														
Bathing	1														
	2														
	3														
Laundry	1														
	2														
	3														
Drinking water for animals	1														
	2														
	3														

Question 6. Do you believe that the time and effort employed in obtaining water is:

Too much ( ) Normal ( ) Little ( )

If the answer is "too much," ask: If you would be able to spend less time in obtaining water, in what activity would you use the time saved?

---

Ask only those who pay for water.

Do you think the cost of water is: High ( ) Normal ( ) Low ( )

Question 7.

- a) Would you be willing to spend more money in order to obtain a better quality of water for drinking and other purposes?

no ( ) Yes ( )

If answer is no, ask why? \_\_\_\_\_

---

If answer is yes, ask: Little more ( ) Much more ( )

- b) Would you be willing to spend more money in order to obtain a closer source of water for drinking and other purposes?

No ( ) Yes ( )

If answer is no, ask why?

If answer is yes, ask: Little More ( ) Much more ( )

- c) Would you be willing to spend more money in order to have water at a distance of 30 feet from your house?

If answer is no, ask why?

If answer is yes, ask: Little More ( ) Much more ( )

Question 8. For those who carry water only:

- a) Do you meet and talk with other people on your way to and from obtaining water?

Yes ( ) Sometimes ( ) No ( )

- b) Do you think this is good? Yes ( ) No ( ) Why? \_\_\_\_\_
-



Question 9. For those who pay for water:

How much do you pay for your water supply? \_\_\_\_\_

How much do you and your family earn per month? \_\_\_\_\_

Question 10. Do you have any idea of what could be done in order to help you obtain a better quality of water?

Yes ( ) No ( ) If answer is yes, what is your idea? \_\_\_\_\_

\_\_\_\_\_

Question 11. Why do you think this hasn't been done before? \_\_\_\_\_

\_\_\_\_\_

Question 12 and 13. Objective: To determine if the wastewater disposal method is harmful for health.

Question 12. How do you dispose of wastewater?

( ) throw it on the street

( ) throw it on the ground

( ) throw in into drainage ditch

( ) use it for the animals

( ) sewerage system

( ) other (specify) \_\_\_\_\_

Question 13. Does wastewater remain close to your house? Yes ( ) No ( )

Questions 14 and 15. Objective: To find out about excreta disposal and if the interviewed observe any relationship between the disposal method and health.

Question 14. What system do you use to dispose of excreta (use local name)?

( ) latrine

( ) vault with collection

( ) bucket night soil collection

( ) leave it on the ground

( ) leave it for the animals

( ) septic tank with flush toilet

( ) other (specify) \_\_\_\_\_

Question 15. Do you think this is the healthiest and best method of disposal?

Yes ( ) No ( ) Don't Know ( ). If answer is yes, ask why?

---

Questions 16 and 17. Objective: To find out if they are used to working with other people and if there is a community organization that they can use in order to improve their methods of water supply and waste disposal.

Question 16. Do you sometimes work with other people in things such as:

( ) Building houses

( ) Building roads

( ) Agricultural work

( ) Marketing crops or goods

( ) Other (specify) \_\_\_\_\_

Question 17. Do you think you could work with other people to improve water supply or excreta disposal?

Yes ( ) Perhaps ( ) No ( )

If answer is yes or perhaps, ask:

With whom would you be willing to work? \_\_\_\_\_

Under what conditions? Voluntary work ( ) Exchange work ( ) Paid work ( )

Questions 18, 19, 20 and 21. Objective: To use the information for correlation with other information from different social and economic groups.

Question 18. Age ( ) 15 to 24  
( ) 25 to 34  
( ) 35 to 44  
( ) above 45

Question 19. Occupation of head of household \_\_\_\_\_

Question 20. Number of persons in family 15 years old or older (include the interviewed)

Question 21. Number of persons in family less than 15 years old \_\_\_\_\_

**Annotated Bibliography**



Annis, Sheldon, and Stephen B. Cox. The integration of small-scale irrigation and village potable water systems in Guatemala. Water Supply and Management, 1980.

In this paper, the authors argue for an integration of small-scale irrigation and potable water projects, exploring available technologies, their benefits to the rural population of Guatemala, the issues to be addressed, engineering and economic issues, program design, institutional and community equity, and the further research that needs to be carried out.

Biswas, Asit K. Water for the Third World. Foreign Affairs, Vol. 60 No. 1, (fall 1981): 148-166.

In this paper the author discusses the factors for and against the completion of the goals of the International Drinking Water and Sanitation Decade.

Blankwaardt, Bob. Hand Drilled Wells: A Manual on Siting, Design, Construction and Maintenance. Rwegaralila Water Resources Institute, Dar Es Salaam, Tanzania, 1984.

Combination reference book and manual, Blankwaardt's book, originally developed for students at the institute, could be instrumental to craftsmen, technicians, practicing engineers, and project planners. The actual development of a village well in Tanzania is used as an example. Important operations are presented with step-by-step procedures and the book is illustrated with numerous drawings and photographs.

Blum, Deborah, and Richard G. Feachem. Measuring the impact of water supply and sanitation investments on diarrheal diseases: problems of methodology. International Journal of Epidemiology, 12(3) (1983):357-365.

In this review of the published literature on the impact of water supply and/or excreta disposal facilities on diarrheal disease, these authors examine several methodological problems that hamper the drawing of definitive conclusions from these studies.

Briscoe, John. The role of water supply in improving health in poor countries (with special reference to Bangladesh). The American Journal of Clinical Nutrition, Nov. 1978: 2100-2113.

The relationship of water supply to cholera transmission in Bangladesh is examined. An attempt is made to explain the apparent finding that users of tubewells do not have lower transmission rates than those who use canals, rivers, or tanks for drinking. Five hypotheses are put forth to explain the finding and are compared.

Briscoe, John. Water supply and health in developing countries: selective primary health care revisited. American Journal of Public Health, 1984: 1009-1113.

The author examines the procedures used in calculating the cost effectiveness of water supply and sanitation as components of primary health care and finds them inadequate. The calculations are misleading since gross rather than net costs have been used and the health impacts of programs have been under-

estimated. The methodology used is biased against water supply and sanitation and other programs with multiple outputs.

It is further argued that if poor women in developing countries were to choose the mix of activities to be included in public health care programs, improved water supplies would frequently constitute part of that mix.

Brush, R.E. Wells Construction--Hand Dug and Hand Drilled. Peace Corps Information Collection and Exchange, 806 Connecticut Avenue, NW, Washington, D.C. 20525, 282 pp.

This is an excellent manual of practical well digging and drilling techniques. It contains comprehensive and detailed information for most hand drilling and digging methods. Any program involved in these activities must have a copy of this publication.

Cairncross, S., and R. Feachem. Small Excreta Disposal Systems. Ross Institute, Information and Advisory Service, Ross Bulletin #8, January 1978.

A practical guide for those coping with problems of sanitation in developing countries. Covers a range from pit latrines to sewerage, with many photographs and diagrams. Discusses health, social, and technical aspects.

Cairncross, S., and R. Feachem. Small Water Supplies. Bulletin No. 10, The Ross Institute, London School of Hygiene and Tropical Medicine, Keppel Street, London, WC1 7HT (also available from ITDG), 78 pp.

This handbook is not "aimed at those engaged on large scale rural water supply programs, but rather at someone who wishes to build only a few supplies using equipment easily available to him..." Topics covered include sources of water, raising water, water treatment, storage, pipes, water distribution, and purification. The information is clearly presented and more easily understandable for persons without a technical background than the work listed above by Annis and Cox. It is not as comprehensive and can be used only for design of relatively small water systems. A useful non-cluttered reference.

Campbell, Michael D., and Jay H. Lehr. Water Well Technology. New York, McGraw-Hill, 681 pp. 1973.

A textbook of field-applicable principles of groundwater: pollution, drilling, well construction, and well operations. Contains a lengthy annotated bibliography.

Casley, Dennis, and Denis Lury. Monitoring and Evaluation of Agricultural and Rural Development Projects. World Bank, Johns Hopkins University Press, Baltimore, MD. 1982.

This book provides a very readable overview of monitoring and evaluation for any type of development project. It is particularly helpful for those with limited background in and exposure to monitoring and evaluation issues. The book and its examples are strongly oriented to Third World situations. Highly recommended.

Darrow, K., K. Keller, and R. Pam. Appropriate Technology Source Books, Volume I and II. Volunteers in Asia, Appropriate Technology Project Box 4543, Stanford, California 94305, 1981.

These two sourcebooks include reviews of over 60 publications concerning water supply and sanitation. Many of the publications reviewed are basic design and construction manuals for appropriate technologies such as handpumps, hydraulic rams, gravity-flow systems, etc. An excellent guide for obtaining further information on a wide range of topics.

Egypt Water Use and Management Project. Technical Report No. 79. A Technical and Economic Analysis of Low Lift Irrigation Pumping in Egypt. Water Distribution Research Institute, Government of Egypt.

A technical and economic comparative analysis of a variety of low-lift (less than 3m) water pumping devices, including waterwheels and axiel pumps, and pumps driven by animals, electricity, and fossil fuel engines. The study was based on the results of field tests and primarily focused on water supply for irrigated agriculture in Egypt.

Elmendorf, Mary. Women, water and waste beyond access. WASH, 1980.

The author, going beyond simple considerations of access to water and sanitation facilities, explores the multiple impacts of improved water supply and sanitation programs on the lives of poor women and children and highlights ways in which women can be key agents in assuring that projects will have a more significant impact on all the target population.

Esrey, Steven A., and Jean-Pierre Habicht. The impact of improved water supplies and excreta disposal facilities on diarrheal morbidity, growth, and mortality among children. Cornell University, Division of Nutritional Sciences, Ithaca, New York, 1984.

In this review of the literature, the authors attempted to establish a cause-effect relationship between water and sanitation and diarrheal morbidity, nutritional anthropology, and mortality. They found that excreta disposal facilities are more effective than improved water supplies for lowering diarrheal morbidity and mortality rates and for improving child growth. Water supply improvements by themselves may have limited effectiveness in improving health.

Esrey, Steven A., and Jean-Pierre Habicht. Nutritional anthropometric indicators for evaluating water and sanitation projects. Paper presented at the International Workshop on Measuring the Health Impact of Water and Sanitation Programmes, Cox's Bazaar, Bangladesh, 21-25 November 1983. Division of Nutritional Sciences, Cornell University, Ithaca, New York, 1983.

This paper presents an analysis of the use of nutritional anthropology in the evaluation of water and sanitation projects in view of the confounding variables that affect the use of this and other indicators.

Faiia, S. Gravity Flow Water Systems--Practical Design Notes for Simple Rural Water Systems. Available from CARE New York, 52 pp.

This manual covers the general principles involved in the design of branched gravity-flow water systems serving several thousand people. Design parameters for storage and hydraulic design of pipelines are extensively covered with many examples. Design guidelines are suggested for conditions similar to those prevalent in Southeast Asia. Appendices include general explanation of flow and head losses in closed pipes, head loss calculations, steps in survey and design, and a sample design. This manual is complemented by a set of 23 design problems with solutions.

Feachem, Richard, M. McGarry, and D. Mara, eds. Water, Wastes and Health in Hot Climates. London, John Wiley, 1977.

An interdisciplinary approach (engineering, health, social, economic) to the problems of water supply and waste disposal in rural areas of tropical developing countries. A particular focus is on the implications for health.

Fraenkel, Peter L. 1984. FAO Irrigation and Drainage Paper: Prime-Movers and Pumps for Small-Scale Lift Irrigation. I.T. Power Ltd., Mortimer, Reading Berks, UK. October. Second Draft.

Encyclopedic reference to small- and medium-sized pumping systems. Discussion of matching power source to pump in system. Meant to replace FAO booklet "Water Lifting Devices for Irrigation," 1956. A "basis for comparing all present and (near) future options for lifting irrigation water on small- and medium-sized landholdings (0.25 to 25 ha.)."

Fraenkel, Peter. The Power Guide: A Catalogue of Small-Scale Power Equipment. Intermediate Technology Publications, 1979.

A well-illustrated document covering a range of equipment adapted to various energy sources: sun, wind, bio-mass, internal combustion, external combustion, and electricity.

Freeman, Howard, Peter Rossi, and Sonia Wright. Evaluating Social Projects in Developing Countries. Development Centre of the Organization for Economic Cooperation and Development. Paris, 1979.

This book is less readable than Casley and Lury, Monitoring and Evaluation of Agricultural and Rural Development Projects (see citation); but it provides abundant, detailed discussion of evaluation issues. The field examples of evaluation problems are excellent. Less attention is devoted to monitoring problems.

Gaymans, Huub. Health impact of the Kampung Improvement Programme in West Java: methods and results. Paper presented at the International Workshop on Measuring the Health Impacts of Water and Sanitation, Cox's Bazaar, Bangladesh, 21-25 November 1983.

An evaluation of the Kampung Improvement Programme (KIP) is reported. Improvements consisted in building semi-public MCK (combined bath, toilet, and



water facilities). While some data were not useful, some beneficial effects on health and living standards are reported.

Gibson, U., and K. Singer. Small Wells Manual. Health Service, Office of War on Hunger, Agency for International Development, Washington, D.C. 20523, 156 pp.

This manual contains information on well construction, design, and development primarily using relatively sophisticated equipment. The information presented is of a technical nature but generally understandable and useful for any program involving sophisticated drilling equipment. The manual also contains useful sections on the hydrologic cycle, groundwater occurrence, and pumping equipment.

Halcrow, W., and I.T. Power. Handbook of Solar Water Pumping. World Bank, London, 1984.

Halcrow, W., and I.T. Power. Small-Scale Solar-Powered Pumping Systems, the Technology, Its Economics and Advancement. World Bank, Washington, D.C., 1983.

Hebert, James R. Effects of components of sanitation on nutritional status: findings from South Indian settlements. International Journal of Epidemiology, 1985: 143-152.

In this study, pre-school children in three urban communities in Madras, India, were followed to determine the relative effects on growth of sanitation factors. Children from 18-36 months of age benefit most from their own and their parents' sanitary behavior. Older children benefit from availability of resources for hygiene. Children under 18 months tend to be unaffected by any of the sanitation-related variables.

Henry, Fitzroy J. Environmental sanitation infection and nutritional status of infants in rural St. Lucia, West Indies. Transactions of the Royal Society of Tropical Medicine and Hygiene, 75 (1981):4,507-513.

The author presents a study of babies in three valleys of St. Lucia, which had different levels of water supplies and latrine facilities. The prevalence of diarrhea and intestinal helminths reduced as sanitation improved, and the growth of the children was significantly better in the improved areas.

Henry, Fitzroy J. Health impact of water and sanitation interventions in St. Lucia. Paper presented at the International Workshop on Measuring the Health Impacts of Water Supply and Sanitation, Cox's Bazaar, Bangladesh, 21-25 November 1983.

A study carried on in parallel with the introduction of piped water and latrines for the control of Schistosoma mansoni in which children in valleys with water and latrines have less diarrhea, intestinal parasites, and malnutrition than those in the valleys without. The quantity of water used per household is further inversely related to the morbidity in children. Families that use less than 25 litres per head per day are particularly at risk. Children in households with both water and latrines experience considerably

less infection than those with water alone. The added latrine does not further reduce the prevalence of malnutrition.

Henry, Kevin. Community Water Supply--Guidelines for Future CARE Programming. CARE, New York, 1982.

Hirshberg, G. The New Alchemy Water Pumping Windmill Book. Brick House Publications, Andover, MA, 1982.

Hodgkin, Jonathan and Richard McGowan. Wind pump field tests in Botswana -- Preliminary technical and cost comparisons. Associates in Rural Development, Inc., Burlington, VT, 1986.

Report of the results of a comparative testing and evaluation program of wind-driven water pumps conducted by the Botswana Renewable Energy Technology project.

Hofkes, E. H., editor. Small Community Water Systems--Technology of Small Water Supply Systems in Developing Countries. IRC Technical Paper N. 18, International Reference Center for Community Water Supply and Sanitation, P.O. Box 93190, 2509 AD, The Hague, The Netherlands, 442 pp.

This book provides a broad introduction to the technology of small water supply systems in developing countries. Topics covered include planning and management, water quantity and quality, water sources, rainwater harvesting, springwater tapping, groundwater withdrawal, surface water intake, artificial recharge, pumping, water treatment, aeration, coagulation and flocculation, sedimentation, filtration, disinfection, water transmission, and water distribution. None of these topics is covered in any great detail, but sufficient information is provided to illustrate basic principles. Drawbacks of the book are its orientation to those with a technical background and its generally poor bibliography. Nevertheless, it is the most comprehensive survey of water supply technology available and a useful reference.

Hughes, James M. Potential impacts of improved water supply and excreta disposal on diarrheal disease morbidity: an assessment based on a review of published studies. World Health Organization, Diarrheal Disease Control Program Consultation Report, 1980.

In this review of 43 published studies of widely varying quality, the author concludes that water availability may be more important than water quality or excreta disposal for the control of diarrheal morbidity, the threshold amount being 20-30 liters/capita/day. When that quantity is available, a 20 percent reduction in diarrhea morbidity can be expected.

Indonesia, Government of, Department of Public Works, Directorate of Water Supply, Human Resources Development Project for Community Water Supply in Indonesia. Progress Report No. 3, Sept.-Nov. 1984.

Report of a survey conducted by the Directorate of Water Supply of Community participation as practiced by other agencies and projects in Indonesia. A useful review of these activities.

International Technology Power (I.T. Power). Wind Technology Assessment Study, Vol. 1. Wind Study Report. I.T. Power, Reading Berkshire, United Kingdom, 1983.

International Reference Center for Community Water Supply and Sanitation (IRC). Practical Solutions in Drinking Water Supply and Wastes Disposal for Developing Countries. Technical Paper, Series #20, September 1982.

This document reports the results of a mail survey covering water resources and recovery, water treatment, water transport and use, solar and wind energy, and waste collection and disposal. In Part I, the technical options are described; in Part II, they are summarized.

Isely, Raymond B. Opportunities, problems and pitfalls in using health status measures to evaluate water supply and sanitation projects in Togo, Malawi, and Tunisia. Paper presented at the International Workshop on Measuring the Health Impact of Water Supply and Sanitation Projects, Cox's Bazaar, Bangladesh, 21-25 November 1983.

The author examines the experiences of evaluating three separate water supply and sanitation projects in order to draw out the advantages and constraints of various approaches.

Jordan, Thomas, Jr. Handbook for Gravity-Flow Water Systems. Intermediate Technology Development Group, 9 King Street, London, WC2E 8HN England, 150 pps.

This is an extremely useful manual for design and construction of gravity-flow water systems. Basic design principles and guidelines are presented together with sample calculations. The sections on construction techniques and materials are especially useful.

Kalbermatten, John M., DeAnne S. Julius, D. Duncan Mara, and Charles Gunnerson. Appropriate Technology for Water Supply and Sanitation, A Planner's Guide. World Bank, 1980.

After discussions of the socioeconomic aspects of planning a sanitation program, the health aspects of sanitation, community participation, and the economics of sanitation technologies, the authors compare various sanitation technologies as well as review technology selection. In the last five chapters, these technologies are described in detail.

Kenna and Gilbert. Solar Water Pumping. (It Power 1986 U.K. Mortimer Hill Reading Berks.

Kennedy, W.K., and T.A. Rodgers. Human and Animal-Powered Water-Lifting Devices. Intermediate Technology Publications, London, 1985.

A desk study aimed at determining the possibility for an Intermediate Technology Development Group project relating to human and animal-driven water pumping. Typical costs and technical performance parameters are given for a variety of pumping devices and for a variety of water end uses, including drinking water supply, stock watering, and irrigation.

Laugeri, L. Cadre institutionnel et modalit{s de financement du secteur de l'approvisionnement en eau potable (AEP) et de l'assainissement en milieu rural: sch{ma de travail et etude de cas. Pr{sentation au Colloque International sur l'Approvisionnement en Eau Potable et l'Assainissement, en Zones Rurales, Kasserine, Tunisie, 23-26 novembre 1982.

The author outlines the elements of a national rural water supply and sanitation program and the agencies that compose it and then describes the two phases of the development of such a program, namely, the preparation of a long-term program and that of a short-term program in a pilot zone. Helpful as a planning document at the national level.

Lysen, E.H. Introduction to Wind Energy. Steering Committee, Wind Energy in Developing Countries (CWD), Amersfoort, The Netherlands, 1983.

Mara, D., and R. Feachem. Technical and public health aspects of low cost sanitation programme planning. Journal of Tropical Medicine and Hygiene, 83(2) (1980):229-240.

This paper presents a concise, brief introduction to alternative low-cost sanitation technologies with an initial emphasis on public health aspects, the assumption being that improvements in public health are generally considered to be one of the more important benefits of sanitation programs.

McGowan, R. Current Developments in PV Irrigation in the Developing World. Associates in Rural Development, Burlington, VT, 1985.

McGowan, Richard and Jonathan Hodgkin. Solar pump field tests in Botswana-- Preliminary technical and cost comparisons. Associates in Rural Development, Inc., Burlington, VT, 1986.

Report of the results of a comparative testing and evaluation program for solar-powered water pumps conducted by the Botswana Renewable Energy Technology Project.

McJunkin, F. Eugene. Handpumps. IRC Technical Paper No. 10. International Reference Center for Community Water Supply and Sanitation, P.O. Box 93190, 2509 AD, The Hague, The Netherlands, 230 pp.

A very complete and detailed handbook covering the design, construction, and operation of many different types of handpumps. A necessity for any program involving handpumps design or research. It will assist in evaluating and selecting potential pumps but contains little information on field trials.

McJunkin, F. Eugene. Water and Human Health. Washington, D.C., USAID, 1983.

A thorough review of the relationship of water supply and sanitation to health. Diseases are discussed in four categories with separate chapters devoted to water quality assessment, water disinfection, sanitation, and studies of the health impact of community water supplies. Each chapter has a bibliography and there is an annotated list of field studies in the Appendix.

National Well Association. Appropriate Well Drilling Technologies: A Manual for Developing Countries. Washington, D.C., USAID Office of Health, October 1978.

A discussion of drilling rigs currently in use. The bibliography contains a list of manufacturers.

Pacey, Arnold. Handpump Maintenance. Intermediate Technology Publications Ltd., 1983.

Pacey, Arnold. Technology is not enough: the provision and maintenance of appropriate water supplies. Aqua 1(1):1-58.

A thorough review of the requirements for maintaining a water supply facility of appropriate technology, once it is installed.

Park, J. The Wind Power Book. Cheshire Books, Palo Alto, CA, 1981.

Pescod, M.B. The interrelationship between water supply provision and sanitation services. Paper presented at a conference, Sanitation in Developing Countries Today, 5-9 July 1977, Pembroke College, Oxford.

Even though water supply and sanitation should always be administratively linked, sanitation is frequently the poor relation of water supply. The author discusses this imbalance and approaches to correcting it.

Rahaman, M.M., K.M.S. Aziz, Z. Hassan, K.M.A. Aziz, M.H. Munshi, M.K. Patuari, and N. Alam. The Teknaf health impact study: methods and results. Paper presented at the International Workshop on Measuring the Health Impacts of Water Supply and Sanitation, Cox's Bazaar, Bangladesh, 21-25 November 1983.

Preliminary results of a study carried on by the International Center for Diarrheal Disease Research on the health impact of improved water supply and sanitation. The study block of villages was provided in a stepwise manner with a well with a handpump, pour-flush water seal latrines, and sanitary hygiene education. Comparison villages received no input from the project. Both study and comparison villages were provided free treatment facilities for diarrheal diseases at a nearby clinic.

Blocks of villages were compared with respect to intestinal pathogens and anthropometry. While diarrheal incidence diminished in the study group over the first three years, changes in growth rates were not observed. Children of families less than 150 yards from a well had less diarrhea.

Rybczynski, W., C. Polprasert, and M. McGarry. Low-Cost Technology Options for Sanitation, A State-of-the-Art Review and Annotated Bibliography. International Development Research Centre (IDRC) and World Bank, 1978.

Shuval, Hillel I., Robert L. Tilden, Barbara H. Perry, and Robert N. Grosse. Effect of investments in water supply and sanitation on health status: a threshold saturation theory. Bulletin of the World Health Organization, 1981:243-248.

Based on an analysis of primary sources, the authors developed a theory that populations are unable to experience beneficial health effects of water and sanitation until a certain socio-economic threshold is reached. Likewise these benefits exhibit a saturation effect at higher socio-economic levels. The resulting curve takes on an S-shape.

Srivastava, R.N., B.L. Verma, and M. Sarah. The Jhansi health impact study: methods and results, Department of Social and Preventive Medicine, M.L.B. Medical College, Jhansi, India. Paper presented at the International Workshop for Measuring the Health Impacts of Water Supply and Sanitation, Cox's Bazaar, Bangladesh, 21-25 November 1983.

A presentation of baseline health status of populations of rural Uttar Pradesh in which controls have traditional water supplies and study villages have clean water supplies.

Tomkins, A.M., B.S. Drasar, A.K. Bradley, and W.A. Williamson. Water supply and nutritional status in rural Northern Nigeria. Transactions of the Royal Society of Tropical Medicine and Hygiene, 1978: 239-243.

In a survey of protein-calorie malnutrition in children of a community in Northern Nigeria, among whom gastro-enteritis is common, wasting (80 percent weight/height) was more common (37.9) among those with unprotected water supplies with small quantities than among those with plentiful supplies of protected water (10.2). Similar coliform contamination of all water supplies was demonstrable.

U.N. Environment Programme. Rain and Stormwater Harvesting for Additional Water Supply in Rural Areas, Nairobi, 1979.

Contains brief discussions of techniques of harvesting rain and stormwater.

U.N. High Commissioner for Refugees. UNHCR Handbook for Emergencies: Field Operations. Geneva, 1982.

Principles and practices to follow in case of an emergency with general chapters on aims and principles, protection, needs assessment and immediate response, implementing agencies and personnel, supplies and logistics, and site selection. Chapter 7 is devoted to health, Chapter 9 to water, and Chapter 10 to sanitation and environmental services.

UNICEF. Handbook of Gravity-Flow Water Systems for Small Communities.

UNICEF, United Nations Children's Fund Executive Board. Maintenance of community water supply and environmental sanitation facilities, (E/ICEF/L.1442), 1982.

A general discussion of the problems of maintenance with potential solutions drawn from UNICEF projects in the field.

UNICEF-WHO Joint Committee on Health Policy. UNICEF-WHO joint study on water supply and sanitation components of primary health care. Geneva, 1979.

A thorough discussion based on field studies of the issues involved in making water supply and sanitation integral parts of primary health care programs including: policy matters; community participation; institutional and managerial infrastructure; education and communication; personnel recruitment, training and orientation; technology; and operation and maintenance.

Cases are drawn from Bangladesh, Colombia, Ghana, India, Nepal, and Philippines. An excellent bibliography is attached.

U.S. Peace Corps. Hydrants: A Training Manual. Peace Corps Information Collection and Exchange. (ICE), 1984.

A session-by-session (19) programmed training guide in the design, construction, operation, maintenance, and repair of hydraulic rams.

Volunteers in Technical Assistance (VITA). Using Water Resources. Washington, 1977.

A field manual extracted from the Village Technology Manual, covering the development of water sources, water lifting and transport, water storage and water power, and water purification.

Wagner, E.G., and J.N. Lanoix. Excreta Disposal for Rural Areas and Small Communities. WHO, Geneva, 1958.

Warner, Dennis B. Multiple steps from installing water and sanitation systems to achieving health benefits. Paper presented at the Annual Meeting of the American Public Health Association, Anaheim, CA, 12-16 November 1984. WASH Project, 1611 N. Kent Street, Arlington, VA 22209, 1984.

The author presents the argument that health benefits of water supply and sanitation projects are not automatic but occur only after a number of steps in project implementation have been accomplished and only if certain complementary inputs, such as sanitation, health education, and institutional development, occur.

Warner, D.B., Dominican Republic, consultations on health sector loan II, report of a field trip, 26-30 January 1981. WASH Project, Arlington, VA, 1981.

White, G.F., Bradley, D.J., White, A.U. Drawers of Water: Domestic Water Use in East Africa. University of Chicago, Chicago, IL, 1972.

World Bank. Harvesting Precipitation for Community Water Supply. Washington, D.C., World Bank, 1971.

A report on methods of collecting rainfall runoff for community water supply purposes. Based on field tests in Kenya, the report contains general discussions of the problem design considerations and construction techniques.

World Bank. Rural Water Supply Handpumps Project: Handpumps Testing and Development: Progress Report on Field and Laboratory Testing. World Bank Technical Paper #29, U.N. Development Programme Project Management Report #4. Washington, D.C., World Bank, 1984.

A report on the UNDP/World Bank project for testing 76 pump types in 17 countries. The report focuses on field testing, but also summarizes the results of laboratory testing, including the 23 fully-tested pump models.

World Health Organization. Human resources development for the International Drinking Water Supply and Sanitation Decade. Basic Strategy Document, (WHO/EHE/ETS), 1982.

This document outlines both national strategies for human resource development during the International Drinking Water and Sanitation Decade and strategies for international support of country programs. National strategies include human resource planning, skill development and training management of human resources, and institutional development. The international support strategy looks at mechanisms of international collaboration and is divided into two phases, only the first of which is outlined in detail. It includes the establishment of international machinery, development and dissemination of information and guidelines, conduct of workshops, and consultation. Phase II activities will result from recommendations emanating from the evaluation of Phase I.

World Health Organization. International Drinking Water and Sanitation Decade, Case History No. 4, Maintaining the System. WHO, Geneva, 1979.

A helpful review of community-based maintenance systems in India, Colombia, Bangladesh, and Malawi.

World Health Organization. Minimum Evaluation Procedure for Water Supply and Sanitation Projects, (draft). The International Drinking Water Supply and Sanitation Decade. Geneva, 1983.

A procedure for evaluating water supply and sanitation projects in which emphasis is on institutional, functional, operational, and utilization variables rather than on outcomes. This procedure needs to be adapted to specific country situations. This document provides detailed information about WSS project goals and indicators useful in evaluation procedures.

World Health Organization. Maximizing Benefits to Health. Geneva, 1983.

The document presents an appraisal method to be used in considering all the aspects of a water and sanitation project that must be taken into account if the project is to be of maximum benefit to health. The method can be used to select projects with the greatest potential for success and to detect gaps in existing programs.



Yoder, Robert. Non-agricultural uses of irrigation systems: past experience and implications for planning and design. Paper prepared for the Agricultural Development Council, Inc., Ithaca, N.Y., Cornell University.

In this paper, the author argues for a more general recognition of the fact that rural people the world over use irrigation water for drinking and other domestic purposes. Pointing out the public health disadvantages of poorly managed irrigation systems, he discusses alternative technical approaches to adapting irrigation systems to domestic use.

Zacher, Winifred. The significance of water and sanitation for primary health care workers in developing countries. Hygie, 21-30.

Many of the diseases from which rural populations in developing countries suffer are related to lack of potable water and polluted water. Yet, primary health care workers are ill-prepared to deal with the technical problems associated with water supply or the behavioral problems associated with sanitation.





