



Association suisse pour le développement et la coopération
Swiss Association for Development and Cooperation
St. Moritzstrasse 15
Postfach CH-8042 Zürich (Suisse)

P. O. Box 114,
BAMENDA
Republic of Cameroon
Tel. : 36-17-30
Fax : 36-22-30

Library
IRC International Water
and Sanitation Centre
Tel.: +81 70 80 890 80
Fax: +81 70 85 890 84

CARETAKER MANUAL

FOR

RURAL WATER SCHEMES

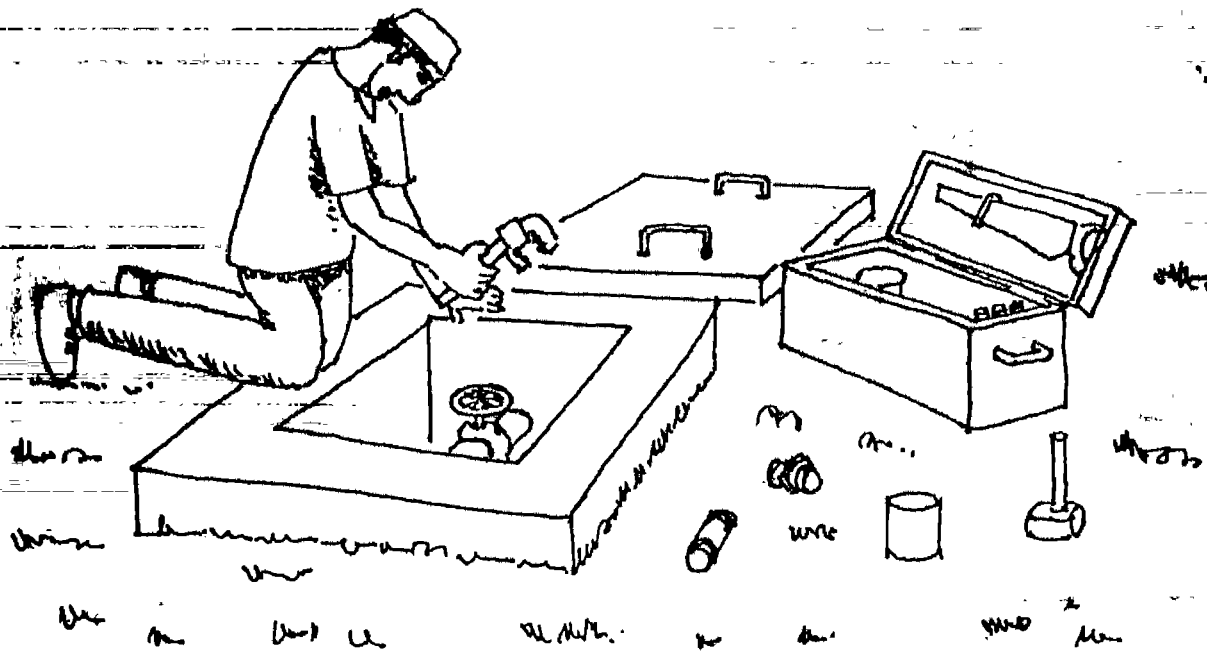

Written by Thomas Zimmermann and Peter Teh Muh
Bamenda, August 1993

Table of Contents

01	Introduction	03
011	A simple gravity water scheme for a village	04
02	Water cycle and water resources	05
021	Water pollution	06
03	Spring catchments, river intakes	07
031	Spring catchments	07
032	Maintenance for spring catchments	07
033	Catchment protection	09
034	Dams and river intakes	11
035	River intake areas	11
036	Maintenance of dams and river intake areas	11
04	Sedimentation-, filter- and storage tanks, control chambers	12
041	Sedimentation tanks	12
042	Maintenance for Sedimentation tanks	12
043	Filtertanks	13
044	Special maintenance for sand filters	13
045	Routine maintenance for a sand filter	14
046	Storage tanks, control- and interruption chambers	14
047	Maintenance for Storage tanks and control chambers	14
05	Standpipes, washplaces and showerhouses	14
051	Private connections	15
06	Water points	15
07	Main- and distribution lines	15
071	Materials	15
072	Maintenance for main- and distribution lines	16
08	Pipe installations and plumbing	17
081	Practical hints for PVC installation	17
082	Practical hints for G.I. pipe installation	17
083	How to use a dicing machine	18
084	Measuring pipes	18
085	How to make watertight joints for G.I. pipes	18
086	Repairing taps stopcocks and valves	21
09	Maintenance of buildings and structures	22
10	Maintenance of other installations	23
101	Wells	23
102	Mechanical water pumps	24
103	Hydraulic rams	24
11	Tools, spareparts and logbook	25
Annex 1: Measuring of spring flow		26
Annex 2: Workreport by Caretaker with list of materials		27
Annex 3: Annual plan of action		28
Annex 4: Example of annual rate of maintenance		29
Annex 5: Suitable trees, shrubs and grasses for catchment areas		30

01 Introduction

Drinking water of good quality and in sufficient quantity is one of the basic needs of mankind. But a village water supply, once constructed, serves its purpose only when there is good operation and regular maintenance (O+M). It has to fulfill the sanitation and hygienic requirements to which it had been designed for, therefore when poorly maintained it could become a serious danger to the population served.

Operation means all actions which deal with the routine work to keep the water scheme and its installations running.

Maintenance can be either preventive or corrective.

- **Preventive Maintenance** is mainly observing well the installations and take the necessary action before a breakdown occurs.
- **Corrective Maintenance** means carrying out minor repairs.

- O + M can only be carried out successfully when there exists a well functioning and active **Water Maintenance Committee** who is respected by the villagers and has a clear task to maintain the water supply.
- A Water Maintenance Committee also needs a well trained and responsible **Caretaker** who is guided, supervised and compensated regularly for his services.

Every structure, but especially water works, needs regular maintenance and repair. Cement in mortar, plastering and concrete exposed to acidity of water will be washed out or eaten up and tanks, dams, chambers, etc. start to leak.

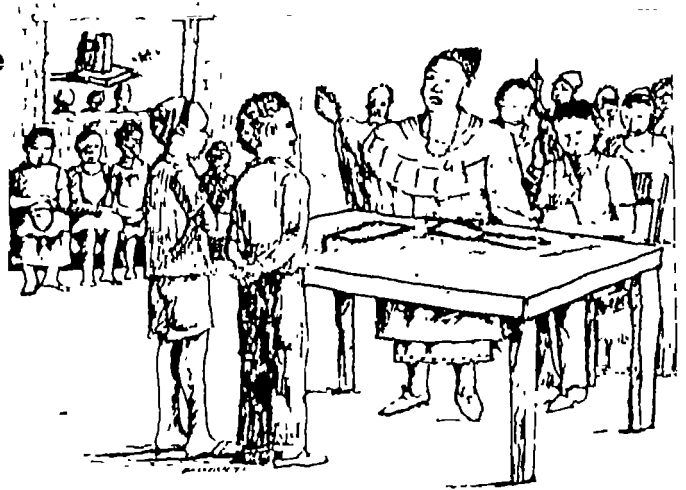

Figure 1: Committee and Caretakers

Maintenance of pipelines is another major task. Damage occurs sooner or later where pipes are exposed, were not properly laid and where movement occurred after installation. A particular case is the Asbestos or AC pipes, of which several hundred kilometres were laid, until PVC was available. Since they consist of a mixture of asbestos and cement, they are also heavily affected by water aggressiveness and, after twenty and more years in the ground, crack and leak. They have to be replaced completely over the next few years.

But also G.I. pipes are exposed to water acidity and corrosion takes place, especially at the threads.

Extension, Rehabilitation and Overhaul of water schemes are not treated in this manual. We also refer to the Guide for Water Maintenance Committees on O + M of Rural Water Schemes which will be introduced to all Committees from 1994.

02 Water cycle and water resources
Figure 3

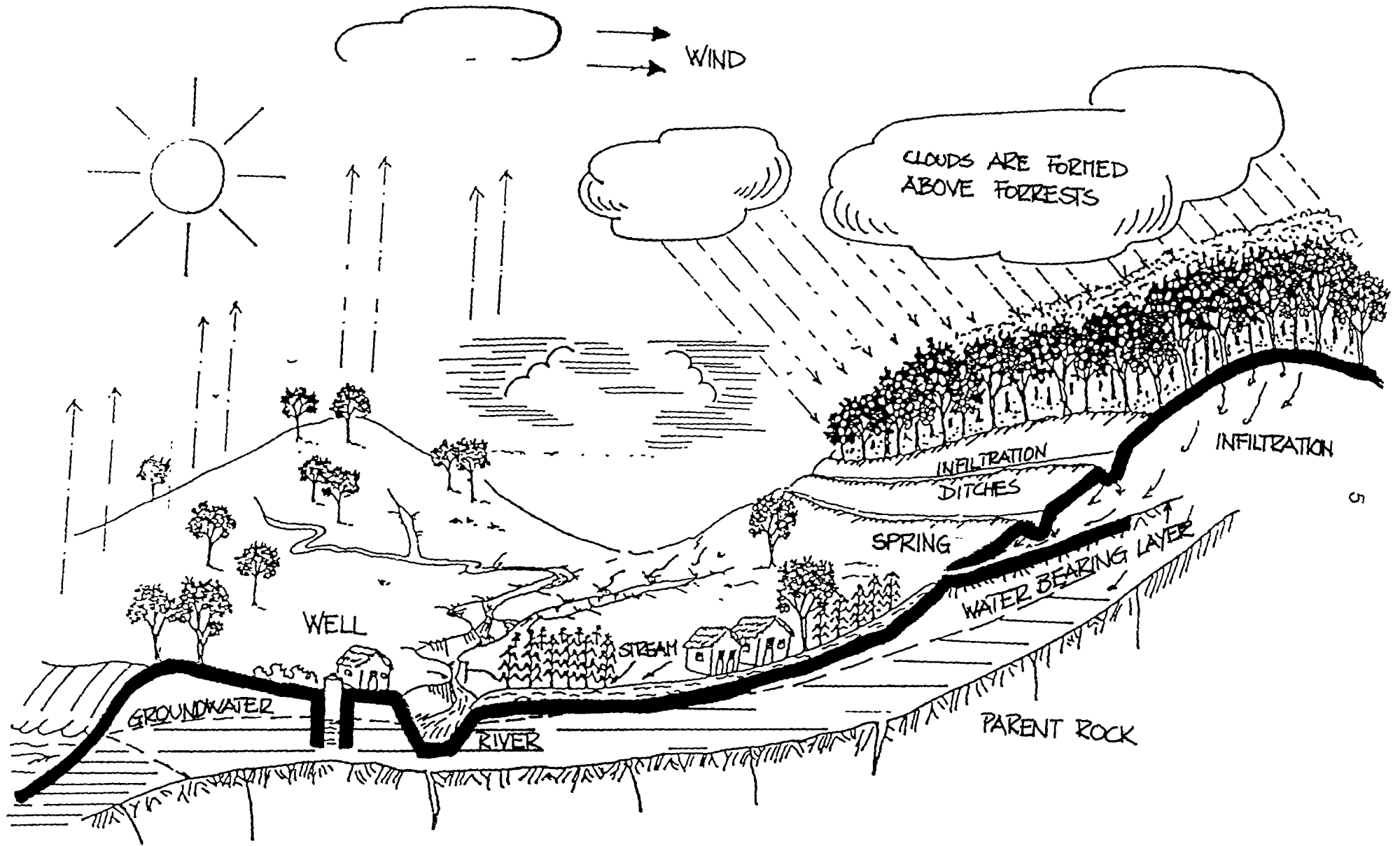

021 Water pollution

Water is contaminated or polluted either chemically or bacteriologically. Improvement of the bacteriological water quality greatly depends on the turbidity of the water. Turbidity is the concentration of suspended solids and is subjected to great seasonal fluctuations. Extremely high peaks might be observed at the start of the rainy season, followed by moderately high values during the remaining part of the wet season. During the dry season, however, the suspended solids concentration might reach quite low levels. In addition, particle size distribution and colloidal stability of the suspension might differ considerably, i.e.- larger particles due to higher velocity are expected in the rainy season.

Chemical contamination:

- Fertilizers, applied in large quantities on field lying near the catchment;
- Pesticides applied on crops and trees near the catchment;
- Weedicides and fungicides;
- Oil, from palm oil production in the catchment area;
- Residues from washing coffee pulp;
- Acid from used batteries just left to decay some where;
- Used engine oil from cars and other engines;

Note: 1 litre of oil can contaminate up to 1,000,000 litres of water.

- Oil from lamps used when repairing water tanks;

Note : Never use an oil lamp inside a tank !

- Refuse dumped near a water intake

Bacteriological Contamination:

All organisms which cause disease for people and animals are foreign to natural water sources. Most of them originate from human and animal excrements, diseases, dead rats, snakes and other animals in touch with water and sometimes decomposing plants and leaves lying in the water source

Another big danger are pit latrines or overflowing or leaking sewer lines or septic tanks near water sources.

Note: Special care has to be taken when locating and constructing wells. They should be at least 50 metres away from the nearest pit latrine.

Refuse dumps favour concentration of bacteriological activity. They pose a big danger of pollution when located near water sources and along river banks. The same applies to agricultural residues, left to rot near water sources.

Parasites:

- Worms or worm eggs which cause disease, especially for children and malnourished people.

03 Spring catchments, River intakes and their catchment areas

031 Spring catchments

A spring catchment is located where a waterproof soil layer, which carries water, reaches the surface. Spring water should never be damed up but left to flow freely. Water under even small pressure might find its own way, bypass the catchment and become lost for use.

Figure 4: A spring catchment under construction

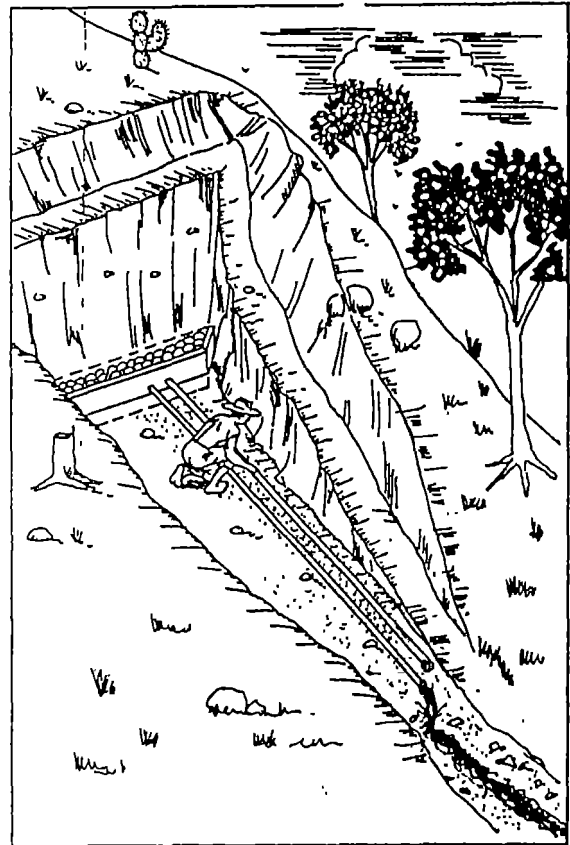
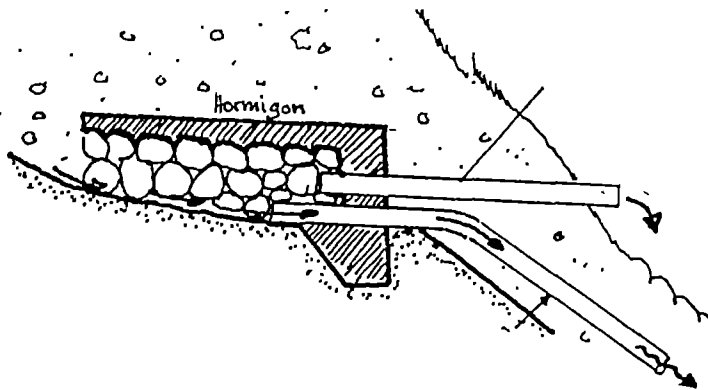

032 Maintenance for a spring catchment

Monthly : - Control on catchment area protection like proper fencing, protection of trees, erosion control, no stray animals. In case of problems immediately inform the committee about it.

- Control flow of water. A good spring does not increase/decrease its flow immediately with the rainfall or drought. Increase of flow should start not earlier than 2 months after the onset of the rainy season.

- Control of silt trap and if necessary cleaning it.

- Control root penetration into channels and chambers.

- Clearing of vegetation around control chamber.

In rainy season - Control the colour of the water after heavy rain fall to check whether there is Infiltration of surface run-off.

Annually : - Call some committee members to show them the catchment and the catchment area.

Spring Catchments which need good observation and special care:

- Catchments which do not have enough soil cover;

- Catchments which are built inside narrow V-shaped valleys, filled with big boulders, where surface run-off infiltrates likely;

- Low lying catchments subjected to flooding.

Figure 5: A spring catchment

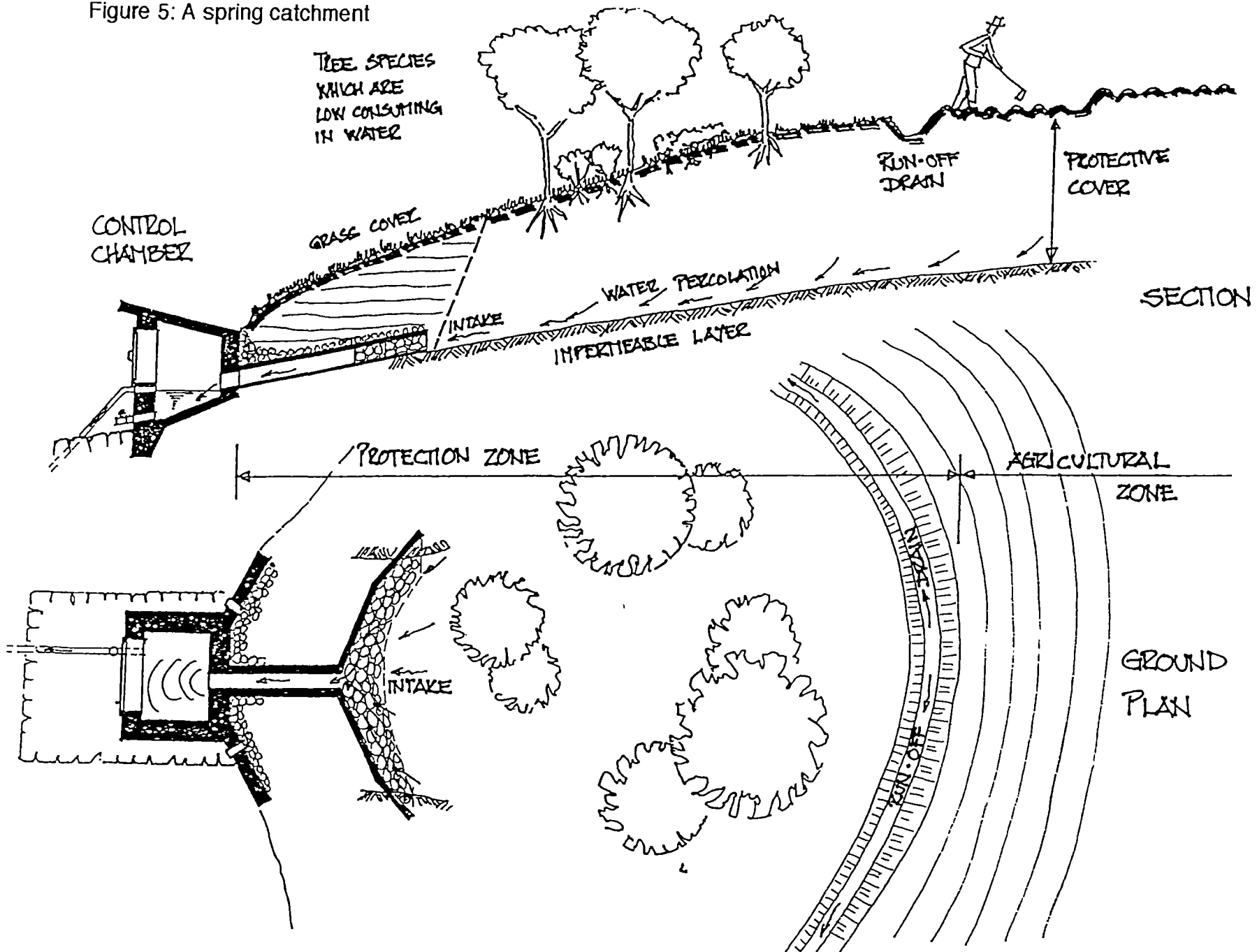

033 Catchment protection

Rapid population growth and the search for land to produce food, fuel, and fodder have led to invasion and destruction of upland forests and watersheds, where normally the most potential water sources are found. Deforestation, annual burning of agricultural and grazing land, intensive agriculture and application of chemical fertilizer, pesticides, etc. are causing widespread soil erosion, high run off of rain water and subsequently **reduce spring flow and danger of water contamination**.

Effective catchment protection involves sensitisation and animation, so that the **whole community**, including the landowners of the particular areas, **are convinced and participate in the protection of its catchment**, not only in the execution of the work but also in planning and decision making.

Definition of Terms:

- A **catchment area** is a topographically defined area that is drained by an underground spring system to one point where the spring emerges.

For our immediate purpose, we define the following areas for **spring catchment protection**:

- 50 m protection zone in all directions (Radius), above each catchment. No farming or grazing is allowed in this area which is also fenced.
- 100 to 300 m radius as extended protective area. No seasonal farming with land preparation or grazing is allowed, but permanent crops, like fruit trees and production of fodder grass, for feeding outside the catchment area, are permitted.
- **Catchment areas for river intakes** are defined as 500 m above the dam and 200 m from the riverbed to each side.

Catchment protection activities:

- Fencing of the catchment area or maintaining the fence if necessary.
- Producing and planting of trees and shrubs; Trees and shrubs provide shade, keep humidity and stabilize the soil, therefore help to prevent erosion. However trees like Eucalyptus, Cypress and Gmelina should not be planted near a water source because they take up a lot of moisture and might cause water shortage. Eucalyptus has to be removed to a distance of at least 50 metres from the spring.
- Sowing grass; Grass grows faster than trees and has a very dense root system which stabilizes the soil very well and helps to increase infiltration.

Catchment protection includes also soil-conservation like making contour bunds, infiltration ditches, etc. For suitable trees, grasses and legumes for catchment protection see annex 7 !

Figure 6 : The catchment protection zone

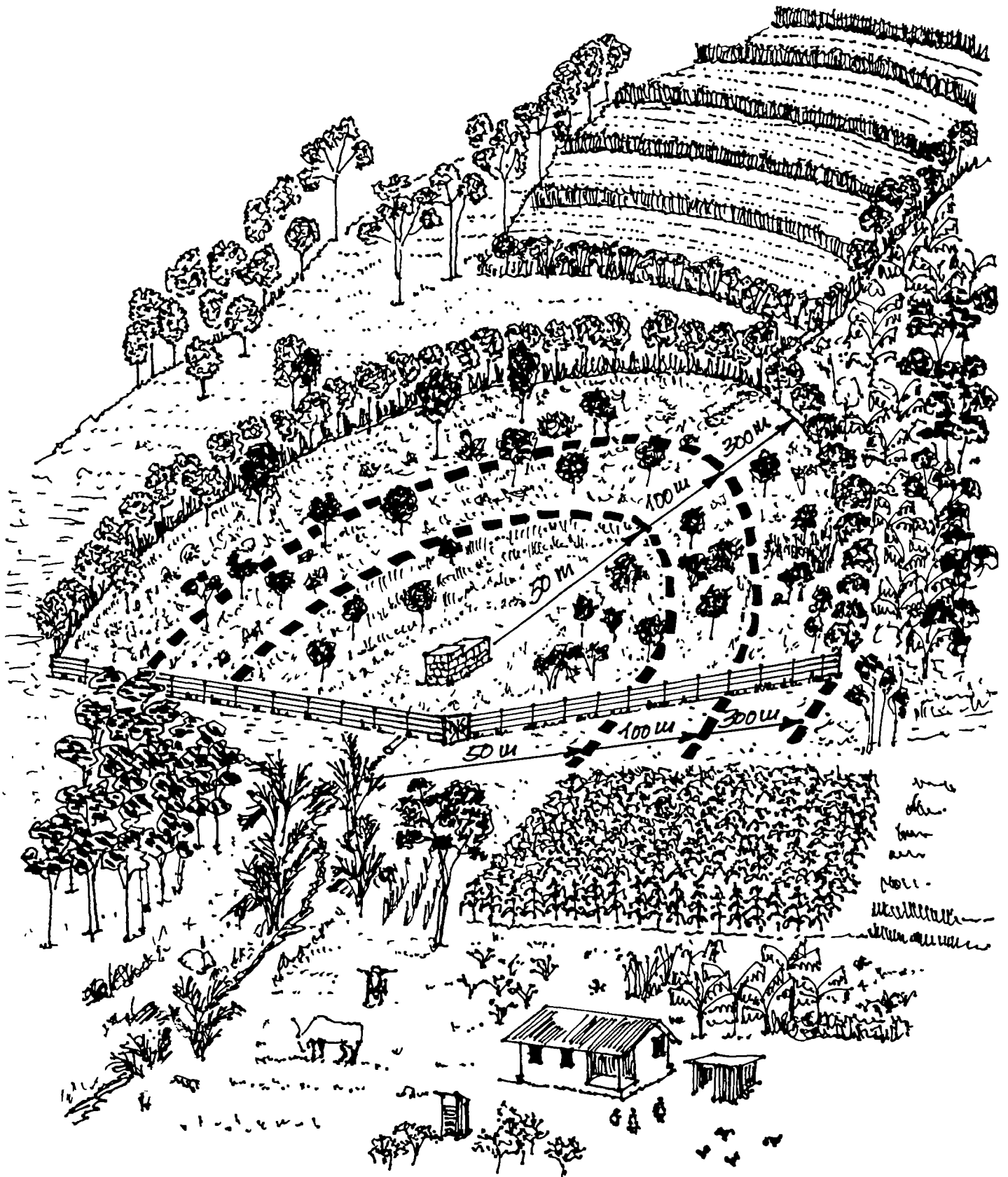

034 Dams and river intakes

In regions where it is difficult to find good springs, river water can be used for the water supply, provided it will be properly treated through sedimentation and filtration. (Maintenance for sedimentation and filter tanks see chapters 042, 044, 045)

River dams are located anywhere along the river above the village, where the river bed is not too wide and where no contamination is expected further up. Usually they consist of the dam with a spillway, a by-pass pipe to empty and clean the basin behind the dam and an intake with a chamber, which also works as a silt trap. A valve must be installed to close the main pipe to the sedimentation tank.

Figure 7:
A dam with
a river intake



035 River intake areas; might be very large, but generally are considered to cover a surface of 200 metres to each side of the river, with a length of 500 metres.

036 Maintenance of dams and river intakes

- Weekly:**
- Inspection of dam, spillway, intake and strainer. Water quality has to be checked and if unusual contamination like any kind of suspended particles, soil run-off, bad smell or a film of oil is observed, its cause has to be found immediately. If there are complications in solving the problem, the CT must quickly inform the Water Maintenance Committee.
 - Inspection of intake area and check whether the regulations are complied with. Any unusual activities have to be reported immediately to the committee.
- Monthly**
- Inspection of sediments behind dam. The basin is functioning as a sedimentation for sand, silt and soil, gravel and stones. Therefore it should never be filled up. In case it has to be cleaned out community work has to be called to do so.

- Annually:
- Checking the dam on cracks, leakages and damage by aggressive water especially spillways below constant flow. Sections where the cement is washed out from mortar joints or concrete have to be repaired in due time.
 - Leakages have to be carefully traced and properly repaired as quick as possible.
 - If serious damages are found a technician has to be called.

04 Sedimentation-, Filter- and Storage tanks, control chambers

All these structures consist of one or more tanks and one or several operation or valve chambers.

041 Sedimentation tanks

The water remains several hours in the tank, flowing slowly towards the outlet. Suspended particles, like soil and silt, sink to the bottom and remain there, while particles floating on the surface are flushed out through the overflow.

Figure 8: Cross section through a sedimentation tank

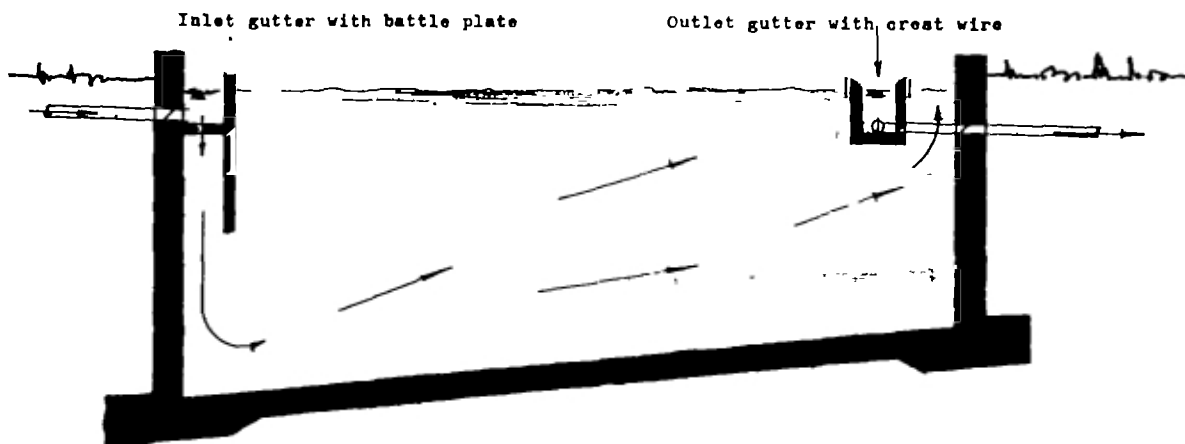

042 Maintenance for sedimentation tanks

- Monthly:
- Drainage and cleaning of tank. Keeping clean all installations, overflow, aeration holes, etc. If necessary grease door hinges, locks, valves, etc. Cut grass around entrance and approach road.
- Every 6 month .
- General check up on structural damages, like cracks and damages by aggressive water (if cement paste inside tank has been attacked).
 - In case leakages are found, they have to be carefully traced and repaired as quick as possible.
 - In case of serious defects, the Committee is informed quickly and has to call for a technician.

043 Filtertanks

In a number of village water schemes using water from small streams and constructed by CDD and Helvetas, so called slow sand filters were constructed. Filtration is the process of purifying contaminated water and slow sand filters, as the name points out, let the water pass by a speed of ca. 30 cm per hour from top to bottom of a sand layer, ca. 1.50 m high. Before the water reaches the filter tank it must have passed through the sedimentation tank, where the bulk of dirt is held back.

To provide uninterrupted services to consumers, sand filters always must have two tanks because of frequent cleaning.

Figure 9: Cross sections through a filter tank

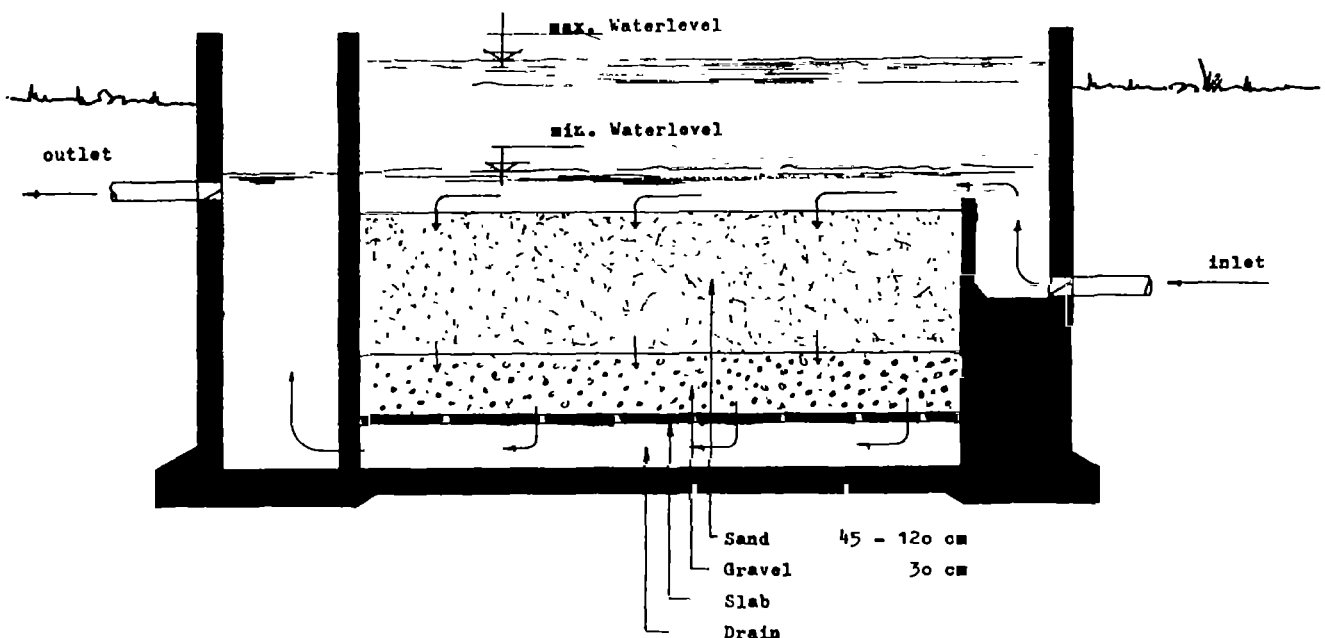

044 Special maintenance for a sand filter

Cleaning the filtersand; The frequency of cleaning the sand filter depends on the amount of water which passes through it as well as on the degree of contamination of the water. During the dry season it might be sufficient to clean the filter every 8 to 12 weeks meanwhile during the rainy season it is necessary to do it every 3 to 4 weeks. Water contamination can also differ from region to region, i.e. in areas where the soil is more sandy contamination by suspended particles of soil is less than in clay and silty soils.

Cleaning means removing, or carefully scraping off, a thin layer of sand, about 2 cm thick. This is done at intervals as explained above until the remaining sand layer is reduced to a minimum of about 45 cm. Then the rest of the sand is removed and properly washed with all the sand previously removed.

Proper cleaning of sand is important. To check if all the dirt has been washed out take a handful of wet sand and rub it between your hands. If there is still any trace of dirt remaining, the sand is not yet clean enough.

Normally cleaning of a sand filter is no problem but if contamination of water is too heavy a technician should be called.

045 Routine Maintenance for a Sand filter

- Twice monthly: - Inspection of the filter tanks. Check cleanliness/contamination of water coming from sedimentation tank.
Keep installations, overflows and drainages clean. Cut grass around the entrance and approach.
- Twice annually: General check up structural conditions like damages by aggressive water, cracks, leakages, etc.

046 Storage Tanks, Control- and Interruption Chambers

Storage tanks help to conserve the water flowing from the spring during the night and balance daily or hourly consumption. They should guarantee a continuous flow of water at all the standpipes.

Control chambers allow control of water quantity and checking of cleanliness of the water coming from the catchments. They also function as **silt traps**.

Interruption chambers are found in pipelines and are placed where pressure exceeds a vertical difference (or altitude) of 70 metres.

Maintenance of all these structures is practically the same.

047 Maintenance for storage tanks and control chambers

- Monthly: - Clearing of surroundings, aeration pipe, drainage, overflows.
- Check water cleanliness, (colour, smell, taste) and water quantity coming from spring, sedimentation or filter tank.
- Check on structural conditions, cracks, leakages, plastering, installations, especially valves, etc.
Empty and clean silt traps.
- Twice annually : Clean the storage tank.

05 Standpipes, washplaces and showerhouses, incl. soakaways

These are public facilities where many people meet daily, and therefore need special attention and maintenance. Cleaning should be carried out on a daily basis and by people nominated by the quarterheads. Good drainage is most important to avoid standing water and breeding places for mosquitoes.

Leaking taps must be repaired or changed immediately, to avoid water loss and drainage problems.

Soakaways usually do not need a lot of maintenance, but in case of clogging, must be cleaned out.

Figure 10: Stand pipe and washplace

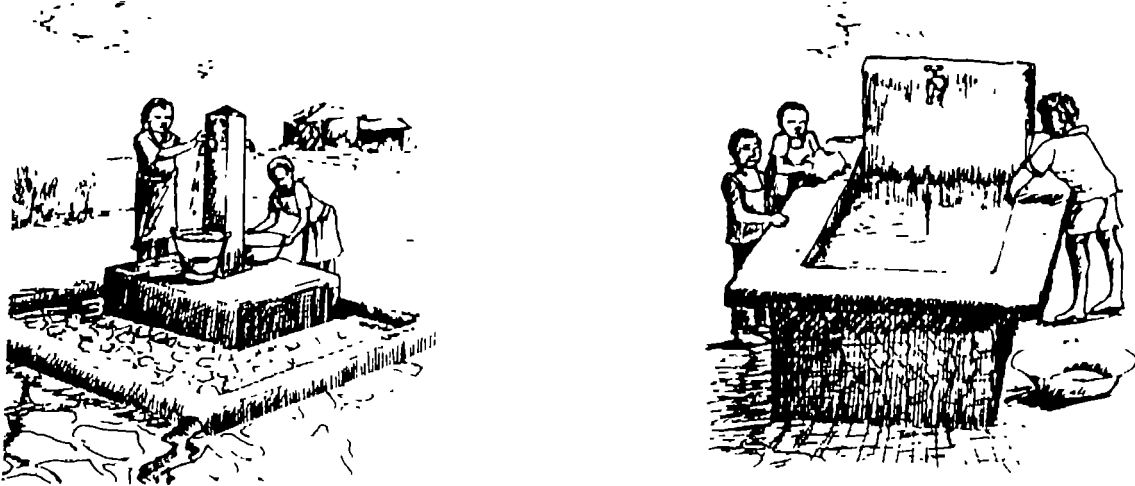

051 Private connections

The Water Maintenance Committee alone decides whether to give somebody a private connection or not, and if yes, under what conditions, like number of taps, fee for connection, annual contribution to O+M, etc. The owner of a private tap also must allow the Caretaker to inspect the installations, at least once a year and commit himself to undertake the necessary repairs if need arises.

If unauthorized private connections are discovered they must be reported immediately to the committee, who then takes corrective action.

06 Water Points

The maintenance of water points is practically similar to an ordinary water scheme. Since there is a minimum of installations a junior Caretaker might do the job but must do it properly.

First, attention has to be paid to the catchment area, which is observed and maintained like any other one. Then comes cleaning of storage tank, wash basin and drainage. Maintenance of water taps is equally important.

07 Main and distribution lines

071 Materials

PVC Pipes, non-pressure, diametre in mm is light-gray, 4 metres in length;

PVC Pipes, NP 10, pressure pipes, diametre in mm, withstanding 10 bars or 100 metres of water column; the pipes are dark grey or black, 6 metres in length.

PVC Fittings, see attached list.

G.I. Pipes, in galvanised steel, diametre in inches, 6.10 metres long.

G.I. Fittings, with ready made threads, see attached list.

Water taps in brass, the very cheap ones (!), bronze or chromated steel, diametre in inches or mm, adaptors to PVC in mm.

Gate valves and stop cocks, in bronze, brass, galv. steel and grey cast iron, diametre in inches or mm, with adaptors to PVC.

072 Maintenance for main and distribution lines

- Weekly:**
- Check whether standpipes, washplaces and showerhouses are clean, no standing water is seen, grass is cut, etc. If not, report to responsible Quarterheads or Committee.
 - In case of watershortage at the taps locate the problem by measuring the spring flow at the source and in the tanks and compare with previously measured figures.
- Try to verify leakages, first by checking all the valves, public- and private taps, then by observing whether any water leaks from the pipeline.
- If the problem persists check on possible clogging or check whether there is air or vacuum in the pipe. These can eventually be eliminated by opening all taps, ventilation valves and gate valves at low points.
- Monthly:** Check all valves and valve chambers. Broken cover slabs and other damages at chambers have to be repaired as soon as possible.
- Twice annually:** Walk along the whole pipeline and check on exposed parts and danger of erosion. Check especially critical spots like river crossings, where pipes pass under roads, cross swampy or rocky places, etc.

Figure 11: A water point

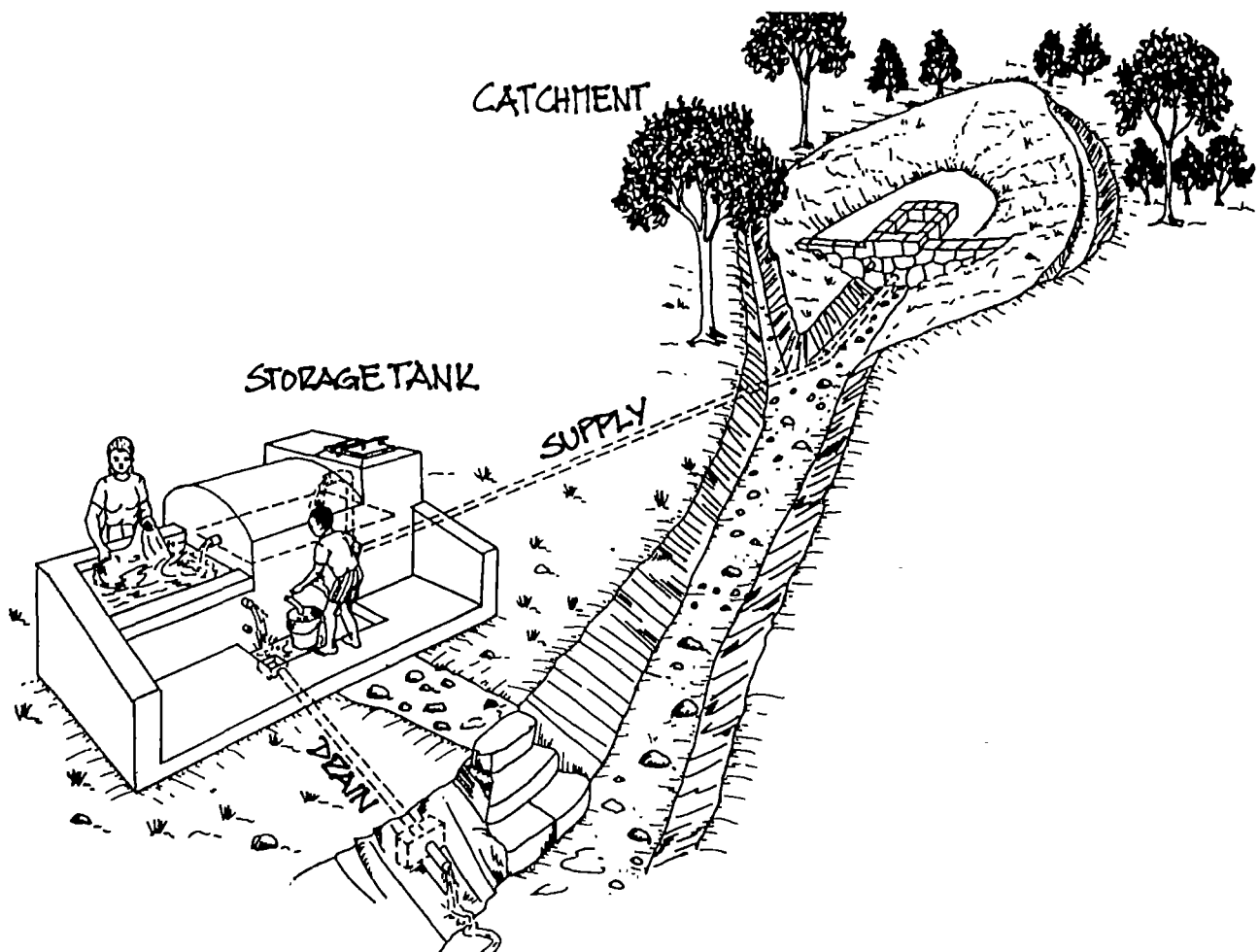

08 Pipe installations and plumbing

PVC Pipes are common all over the world and very easy to install, since they fit into each other (male / female joint), using PVC glue to join them.

081 Practical hints for installation of PVC pipes

- When **cutting PVC** by saw, splinters must be removed, to avoid interfering with good joining.

- **Making female ends by heating** (in case no sockets are available). One pipe end is heated and then put over another pipe of the same diameter, turned slowly, then off and put into cold water. The length of the female end is the same as the diameter of the pipe.

- **Bending of PVC pipes**, or making bends yourself, in case there are no bends or elbows available, is also done by heating and followed by bending. The operation is as follows:

1. Calculate the length of the bend by measuring the outside diameter of the pipe and multiplying by 5.
2. Measure and mark the bent section, cut the pipe at the mark when you make a single bend.
4. Fill the pipe with dry sand.
5. Heat the bent section or the single piece of pipe gently and regularly until it becomes soft and flexible.
6. Put the pipe level on the floor and bend it to the desired angle.
7. Cool the pipe with water and let the sand flow out.

G.I. Pipes are joined by screwing them together and therefore need threads, which are cut with the dicing machine. Other tools like pipe wrenches, shifting spanner, hacksaw with blades, hemp and putty, etc. are also needed.

082 Practical hints for installation of G.I. pipes

Proper preparation of installations and correct measuring of steel pipes is very important to avoid problems on the job site. Before measurements are taken the following points must be clear:

1. Location, dimensions and diameter of all pipes;
2. Diameter of all pipes and fittings;
3. Fittings foreseen to be used must be available.

G.I. pipes are 6.10 m long and have both ends diced. **When transporting them sockets should be fixed to the end to prevent damage** of the diced ends by loading and offloading.

Dicing machines with proper and complete sets of teeth are few in the field and they are very expensive to buy. Therefore it is **advisable to make a detailed list of G.I. pipes, with diameter and length, and then order them with the ends already diced**. But again, care has to be taken in transporting them, to avoid damage to the diced ends.

When dicing a metal pipe we weaken its structure by cutting off part of its thickness. Therefore **care has to be taken in making clean threads**. Too much cutting not only causes leakages at the joints but also weakens them.

Pipes should never be transported or moved after they have been joined together.

The length of the diced part or thread varies according to the diameter of the pipe. The following measurement should be kept in mind following the Table of thread length:

3/8" = 10 mm	1/2" = 13 mm	3/4" = 15 mm	1" = 17 mm
1 1/4" = 19 mm	1 1/2" = 19 mm	2" = 24 mm	2 1/2" = 27 mm
3" = 30 mm	4" = 40 mm		

083 How to use the dicing machine

- 1) Choose the correct cutting teeth, according to the diameter of the pipe.
- 2) Fix the guiding teeth of the machine.
- 3) While pushing the machine frontally against the pipe, keep turning the handle of the machine clockwise and anticlockwise to form the thread.
- 4) Keep oiling the threads on the pipe to facilitate turning and form them properly and clean.
- 5) Measure and check the length of the thread, according to the list given above.
- 6) Clean the thread and test its size by fitting a socket.

084 Measuring pipes

When calculating the length of a pipe we measure first the distance between the fittings and then add twice the length of the thread, according to the table above.

Example 1: During installation a vertical pipe, diameter 1" has to be joined with another vertical pipe, at a distance A-A of 525 cm (axis to axis). Tees 1" are used to join the pipes. The thread length for 1" pipes is 17 mm, according to the table.

What is the length to be cut of the joining pipe ?

$$\begin{array}{r}
 \text{Solution: Length} = \text{Distance A-A} = 525.0 \text{ cm} \\
 \text{minus } 2 \times Z = 2 \times 2.7 \text{ cm} = - 005.4 \text{ cm} \\
 \text{plus } 2 \times \text{thread length} = 2 \times 1.7 \text{ cm} = + 003.4 \text{ cm} \\
 \hline
 \underline{522.0 \text{ cm}}
 \end{array}$$

Figure 12

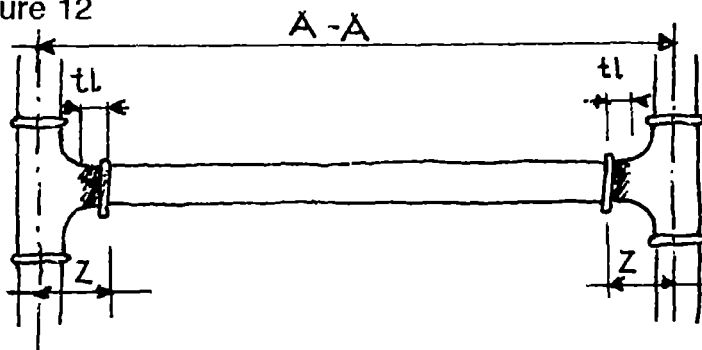

085 How to make watertight joints on G.I. pipes

After dicing the pipe, take a good amount of hemp and put it around the pipe, following the screwing direction, or clockwise. Add putty on the hemp to facilitate the screwing and to make the joint fully watertight. As already mentioned, pipes once joined, should not be moved again, except for minor adjustments.

Fittings for plastic pipes
Figure 13

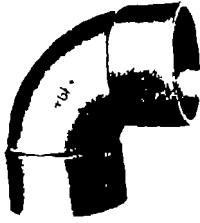

Elbows 90°



Bends 90°



Sockets



Reducing Sockets

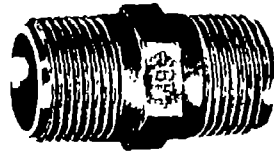

Adaptor Nipples

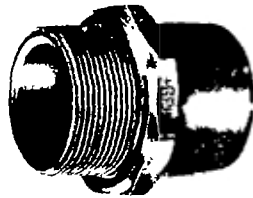
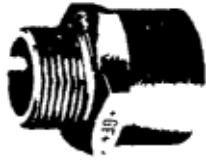

Adaptor Bushes, equal



Unions



Adaptor Unions,



Tees 90°, reducing



Tees 90°



Tees 45°

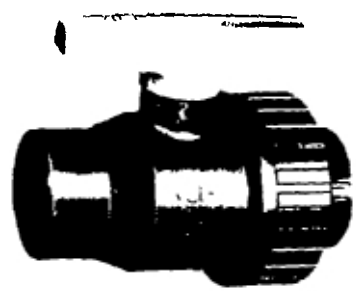

Compact Ball Valve

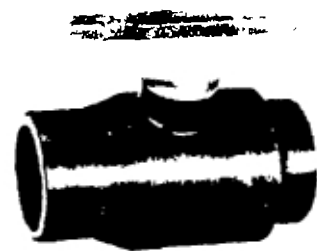

Ball Valve

Fittings for steelpipes
Figure 14

BEND 90° MALE/FEM.

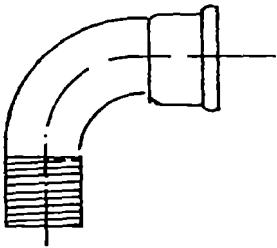

BEND 90° FEMALE

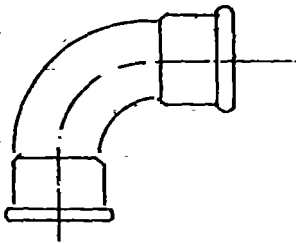

BEND 45° MALE/FEM.

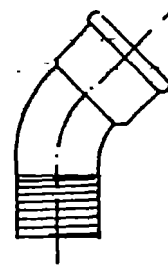

BEND 45° FEMALE

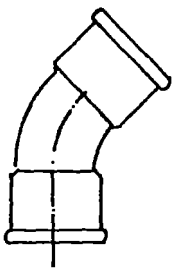

ELBOW 90° FEMALE

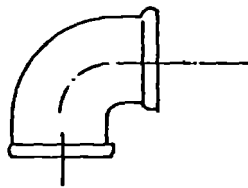

ELBOW 90° MALE/FEM.

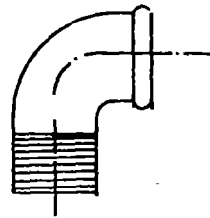

TEE EQUAL

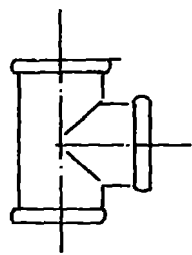

CROSS TEE

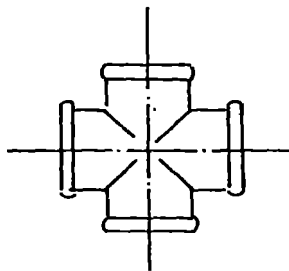

REDUCING SOCKET

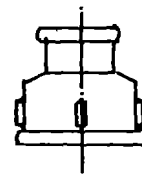

REDUCING BUSH

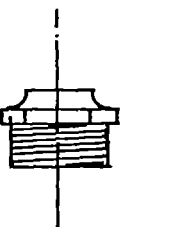

SOCKET

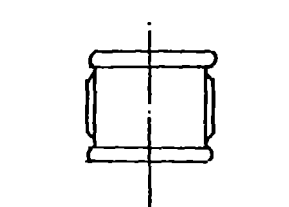

HEXAGON NIPPLE

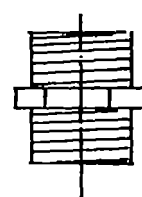

PLUG



CAP

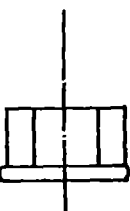

UNION

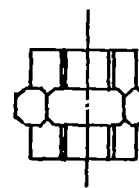

086 Repairing taps, stop cocks and valves

Taps, stop cocks and valves usually are the first parts in a water scheme which leak. If they do so, they have to be repaired immediately. In the figure below you see a cross section through an ordinary tap, with the names of all its different parts. Water can leak between different parts but it is very likely that it leaks first from between the washer and the seating, then from between the spindle and the hemp packing. Spindel threads from cheap taps wear out quickly and such taps have to be replaced. For stop cocks it is similar, depending on frequency of their operation. Also for gate and safety valves, seatings might be worn out after some years. Regular movement however is important in order to prevent them from getting stuck on the seating.

Figure 15: Cross section through a tap and some discharge valves

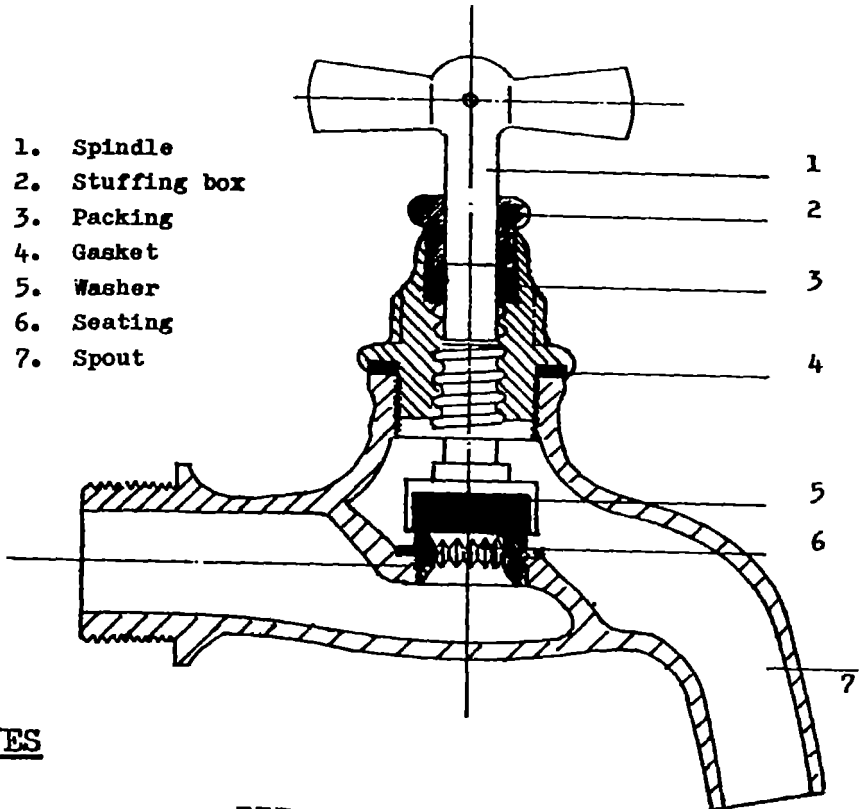

- 1. Spindle
- 2. Stuffing box
- 3. Packing
- 4. Gasket
- 5. Washer
- 6. Seating
- 7. Spout

DISCHARGE AND FLOW VALVES

BIB COCK
(Tap, faucet)

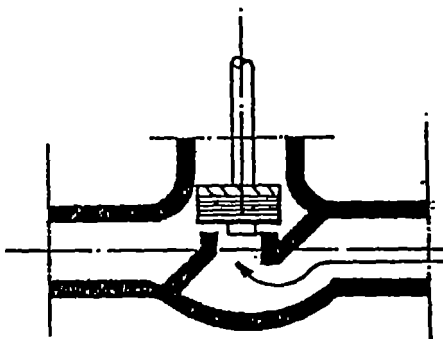
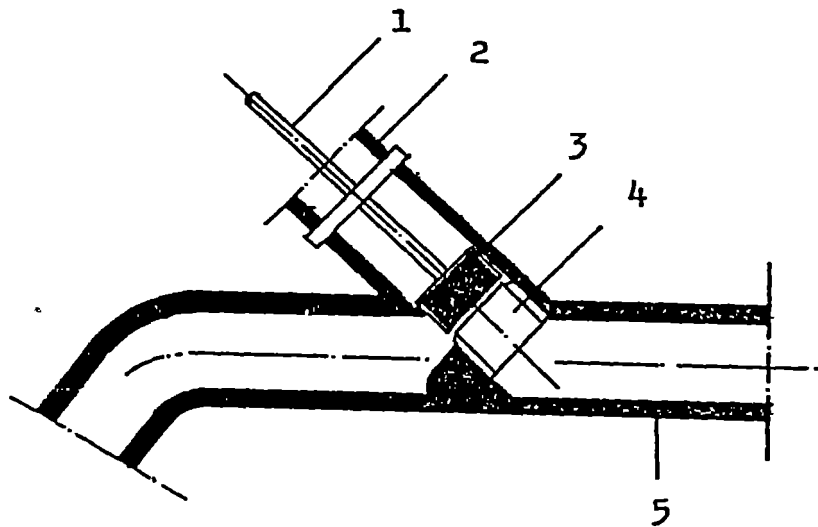

GLOBE VALVE
(Stop valve,
female)

09 Maintenance and Repairs for Buildings and Structures

Tanks outside become overgrown by moss and grass if they are not cleaned from time to time. The fine roots penetrate into the mortar joints, plastering, and concrete and make the structure liable to further damage and deterioration. Frequent cleaning and brushing are therefore recommended and in case of bigger damage repair of plastering, mortar joints and concrete work.

Plastering:

- As already mentioned the biggest problem is water aggressiveness. First the cement paste, if there is any, shows rough patches and soon the water might penetrate through the rendering coat. The leakages are visible at the outside but not necessarily exactly where the cement paste is damaged.

Repair: Roughen up the cement paste by chiselling and brushing it with a strong wire brush. Repair the rendering coat and reapply the cement paste.

Weak or loose plastering is the result of insufficient cement or dirty sand. Repair: It has to be removed and done again.

Minor or short cracks in plastering are usually not serious and can be repaired by chiseling, cleaning, applying a cement slurry and filling them again.

Cracks by settlement or structure failure:

Such cracks are bigger and longer and result in big water loss. They should be repaired temporary to avoid big water loss. However since they appear soon again after the temporary repairs have been done (latest during the following rainy season) and are much more difficult to get rid off, an experienced headmason, a technician or even an engineer has to be contacted to discuss possible solutions.

Leakages along pipes installed in masonry and concrete work:

As a first measure the plastering on the water side, around the pipe must be carefully chiselled as deep as possible, say 5 cm. The hole then is properly brushed and watered. Then a cement slurry is applied and the mortar filled again. Keeping the repaired part wet is important.

Doors and windows

Whether in wood or in metal they are difficult to maintain, because they are often exposed to rain. Frequent painting or application of wood preservative is necessary. Rotten frames and shutters, broken wiremesh, etc. have to be replaced. Locks have to be greased frequently and a second set of keys have to be kept with a committee member.

10.2 Mechanical Water pumps

There are many different types of mechanical waterpumps, driven by diesel, kerosene or sometimes petrol engines, electric motors or even water driven turbines. But we are not going into details during this course. In principle the Caretakers who work for water schemes with water lifting involved, should be able to do the following **routine maintenance**:

- changing oil,
- cleaning the fuel tank
- cleaning or changing oil-, fuel- and air filters,
- check on washers and seals,
- maintain the battery, check the main electrical cables and contacts,
- cleaning and greasing the engine and the pump, etc.

In case of repairs he has to have access to a mechanical workshop nearby.

The main condition that water pumps run trouble free, is a steady inflow of water, free of particles which might block the strainer or even block the pump. Therefore weekly checks have to be made on water quantity at the intake, cleanliness of strainers, pump sumps, regulating valves, etc. In case of repeated breakdowns, an experienced mechanic, a technician or even an engineer should be called in.

10.3 Hydraulic rams

These are water lifting devices powered by water under pressure, coming from a dam at a higher level. With a special valve mechanism, part of the water (approx. 10 to 20 %) is separated and diverted into a supply pipe leading to an elevated tank, meanwhile the rest is flowing off. Pumping is a process of continuous strokes, the pressured water being the energy. Maintenance is similar to pumps, keeping a free and steady flow of clean water is the main condition for good functioning. However, Caretakers working with hydraulic rams should get special instructions.

Figure 17: A water scheme with a hydraulic ram

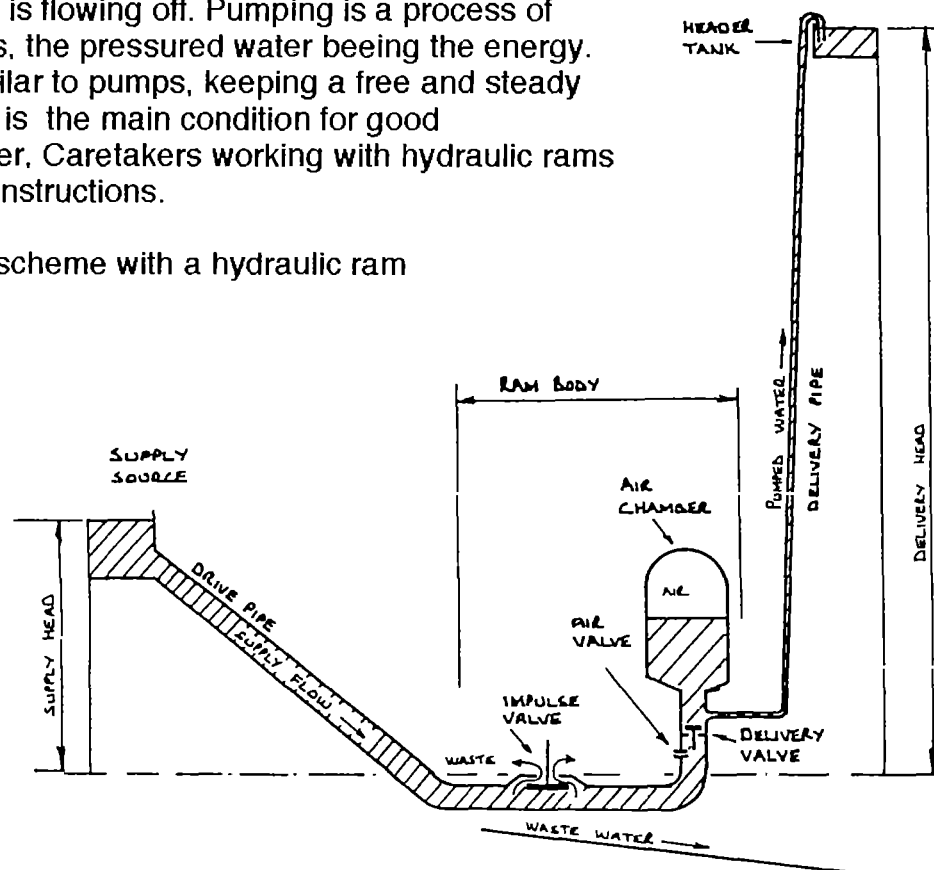

11 Tools, spare parts and logbook

111 The common tools for a caretaker are:

01 Spade	08 Headpan	14 Plastic bucket
02 Cutlass	09 Two Pipewrenches	15 Pincers
03 Metal file	10 Club hammer	16 Round chisel
04 Flat chisel	11 Hack saw	17 Screw driver
05 Carpenters chisel	12 Trowel	18 Shifting spanner
06 Meter	13 Wood saw	19 Pliers
07 Spirit level		

The tools are and remain property of the Committee but the Caretaker is responsible for maintaining them. If a tool is lost, stolen, damaged or worn out it is he who has to report it to the Committee and ask to replace it.

112 Spare parts:

Whatever pipes, fittings and other materials are in stock have to appear in a simple record, i.e. in an exercise book, maintained by the Caretaker and checked from time to time by the Committee. Again it is the Caretaker who finds out what spare parts (and what number) have to be bought. He is responsible for the stock and reports to the Committee about any problems. He also keeps record of the materials received and materials used. See annex 2.

113 Logbook

In the log book we find:

- Report on breakdowns, including the reason if it is known.
- Work carried out by the Caretaker, incl. time spent in hours or days.
- Any ideas, complaints, problems, etc. in direct relation with the water scheme.
- Visitors register, especially visits by technicians, technical adviser, etc.

Annex 2: Workreport by Caretaker with list of materials

Period: From _____ To _____

DATE	WORK DONE	APPROVED BY & REMARKS
05/2/92	Changing of taps in Kango Olu, Manchong, Quarters. Inspection of Storage tank	Used materials from store. Bought 2 taps. Chairman.
09/2/92	Clearing of catchment with villagers. Inspection of control chamber.	Vice Chairman 9/2/92
11/2/92	Gave private connection to Mr. Achu Thomas	Work not finished need glue from Bamenda. Vice chairman 11/2/92

List of Materials Used

DATE	JOB DESCRIPTION	MATERIAL USED	APPROVED BY & REMARKS
05/2/92	Changing of taps in Kango, Olu Manchong Quarter	3 taps 2 taps 2 taps	Chairman 5/2/92
18/2/92	Repair of leakage in RCM School	2 GI union dia 3" 4m dia 3" GI pipe 1 socked dia 3"	Chairman 18/2/92
25/2/92	Repairs of broken slabs in Olu Quat. and palace	2 bags cements 1 dia 6mm rod	Chairman 25/2/92

Annex 3: Annual plan of action

The WMC elaborates an annual Plan of Action in which it plans what to be done, who does it and how ?

Routine Control and Maintenance 1993

NO	STEP	TASK	WHO	DATE
1.	Catchment	Checking of farming, Burning, Erosion Fencing, Leakages, Cracks.	Caretaker MC	April & Nov.
2.	Control Chambers	Cleaning Checking Cracks, doors etc.	Caretaker MC	Jan. July
3.	Storage Tanks	Clearing, Cleaning Washing.	Community Caretaker	Nov. June
4.	Pipeline	Check Indic. Pillars leakages, Erosion, Farming etc..	Caretaker MC	Feb. & Oct.
5.	Standpipes Washplaces Soakaways	Cleaning-Draining " " " "	Community Caretaker Caretaker	Weekly " Jan.
6.	Sed. Tanks	Cleaning & Checking	Caretaker	Monthly
7.	Filters	Cleaning of sand Inspection of sand	Caretaker Community	Jan. Apr. July. Oct.
8.	Quarterly Meetings	Plan for year act., collect. of fees etc..	Chairman/ Secretary	4 times a year
9.	Annual Report	Writing & Distrib. to the different quarters.	Chairman Secretary Treasurer	Nov.
10.	Maintenance fees/levies	Collection of maintenance fees from villagers/ private connection fee etc..	Finance Group	April Oct. Nov.

Annex 4:

Example of an Annual Rate for Maintenance

1. Taxable population of village is 600 inhabitants. The annual rate to be paid to Development Associations per person is 2,000 FCFA.
The percentage given for maintenance is 20% per year.
20% of 2,000 FCFA is 400 FCFA per person for a year.
Therefore the yearly amount for Maintenance Committee given by the Development Association is 400 FCFA x 600 persons is 240,000 FCFA.
The 240,000 FCFA is now the maintenance budget for the year. This amount is paid to the Maintenance Committee.
2. Villages without a Development Association can organize activities within the year to raise fund, such as dances, donations, levies etc..
Example: A levy of 500 FCFA per year is collected from every male in the village as a maintenance fee. With 300 men in the village, the maintenance fee will be, 300 men x 500 FCFA which is 150,000 FCFA.
This money is collected by the finance group of the committee at fixed periods, say twice a year.
3. **WATER DAY:** A village can organize a special day of the year only to collect money for the water in the village, calling it WATER DAY. All villagers shall be educated to know the importance of this day.
4. **PRIVATE CONNECTIONS:** Every individual, households, institutions etc. using water privately shall pay a token fee every year to be used in maintaining the whole water system.

EXAMPLE:

Schools with one stand pipe	= 5,000 CFA/year
Schools with WCs etc..	= 10,000 CFA/year
Health Centers with appliances	= 10,000 CFA/year
Hotels with 5 to 10 rooms	= 15,000 CFA/year
Farms with using water	= 10,000 CFA/year
Individual houses with appliances	= 5,000 CFA/year
Mission yards	= 5,000 CFA/year

The Finance Group of the committee calculates the rates and asks the consumers to pay the various amounts at a given time of the year. The maintenance fee shall be fixed according to the maintenance regulations.

Annex 5: Suitable trees, shrubs and grasses for catchment areas

Trees, Grasses and Legumes for Catchment Areas NWP Cameroon				
Altitude 1000 - 2000 m.a.s.l. Rainfall 1500-2500mm/an. No. dry month: 4-5				
Scient. Name	Common Name	Establish.	Cop.	Use and properties
TREES				
<i>Albizia species</i>	Albizia	seedling	yes	for grazing land, fire resistant
<i>Aleurites monta.</i>	Tung tree	seedling		
<i>Caesalpina</i>	Caesalpina	seedling	yes	thorny live fence
<i>Calliandra</i>	Calliandra	seedling	yes	AF specie, good in firewood prod.
<i>Canarium schwei.</i>	Black bushplum	seedling		local fruit tree
<i>Cassia spectabilis</i>	Cassia	seedling	yes	good for honey production
<i>Cordia milleni</i>	Cordia	seedling	yes	
<i>Croton macrost.</i>	Croton	seedling	yes	
<i>Entada abyssinica</i>	Entada	seedling	yes	for grazing land, fire resistant
<i>Entandrophragma</i>	White mahogany	seedling	no	
<i>Erithrina species</i>	Erithrina	cutting	yes	for live fence, fire resistant
<i>Ficus</i>	Ficus	seed/cutting	no	for live fence, fodder, fire res.
<i>Gmelina arborea</i>	Gmelina	seedling		Invader but good for live fence
<i>Grevillea robusta</i>	Grevillea	seedling	no	Shade tree, difficult to get seeds
<i>Hurungana</i>		seedling	yes	
<i>Leucaena diversif.</i>	Leucena	seed/sedl.	yes	soil stab., gr. manure, acid soils
<i>Maesopsis eminii</i>	Maesopsis	seedling		
<i>Markhamia spec.</i>		seedling		
<i>Newbutonia</i>		seedling	yes	rapid growth
<i>Prunus africanus</i>	Pigeum	seedling	no	preferred for bark (medic. use)
<i>Raphia vinefera</i>	Raphia	seedling	no	wine, baskets, furnitures, mats
<i>Sorindeia species</i>		seedling		
<i>Spatodea campan.</i>		seedling		
<i>Trema orientalis</i>	Trema	cutting		
<i>Vitex species</i>	Vitex	seedling		
GRASSES				
<i>Bracharia ruzizie</i>	Congo grass	seed/stol.		good fodder grass, dense cover
<i>Cynodon dactylon</i>	Giant star grass,	stolons		invader; dense cover, good stab.
<i>Cymbopogon citr.</i>	Lemon grass	stolons		planted on contour for soil stab.
<i>Hyparrhenia</i>	Hiperenia	seed		fodder, roof thatching, easy man.
<i>Imperata cylindrica</i>	Spear grass	seed		invader, indicates poor soil
<i>Panicum max.</i>	Guinea grass	seed/stol.		good fodder, grows on var. soils
<i>Pennisetum cland.</i>	Kikuyu	seed		good fodder grass, dense cover
	Elefant grass	seed		fodder grass, indicates good soil
	Sporo bolos	seed/stol.		fodder grass, suit. for hay
<i>Tripsacum laxum</i>	Guatemala grass	seed/stol.		good fodder, good on cont. bunds
<i>Vetiveria</i>	Vetiver	stolons		planted on contour for soil stab.
LEGUMES				
<i>Crotalaria anagyr</i>	Crotalaria	seed		rapid growth, dense cover
<i>Desmodium</i>	Desmidium	seed		dense cover, good fodder
<i>Pueraria phaseol.</i>	Kudzu	seed		dense cover, good green manure
<i>Sesbania sesban</i>	Sesbania	seed		soil stabil., fodder, on acid soils
<i>Stylosanthes guia.</i>	Stylo	seed		grows on poor, acid soils
<i>Tephrosia vogelii</i>	Tephrosia	seed		high green manure production

•

Handwritten notes or scribbles in the upper right quadrant of the page.

Handwritten mark or signature at the bottom center of the page.